

WPMDH1100xx1S / 173010x42

Magl³C Power Module FDSM – Fixed Step Down Regulator Module

7 - 42V / 1A / 3.3V or 5V Output



DESCRIPTION

The FDSM series of the Magl³C Power Module family is a fixed output voltage, fully integrated dc/dc power supply. The module integrates the switching power stage, control circuitry, inductor and capacitors all in one package.

The module requires no external components for operation reducing design effort and complexity to a minimum.

The FDSM ensures fast time to market and low development costs.

It is pin compatible with the common 78xx linear regulator series. The high efficiency reduces the power dissipation and in many cases a heatsink and assembly parts are unnecessary.

12V to 3.3V conversion achieves up to 89% efficiency.
12V to 5V conversion achieves up to 92% efficiency.

The standard THT package allows for easy assembly.

FEATURES

- Peak efficiency up to 93%
- Current capability up to 1A
- Input voltage range: 7 to 42V
- Output voltage: 3.3V or 5V
- Continuous output power: 3.3W or 5W
- Integrated capacitors and inductor
- Low output voltage ripple at 1A load: typ.15mV (3.3V), typ.20mV (5V)
- Output voltage accuracy: $\pm 2\%$ typ.
- Fixed 350 kHz switching frequency
- Current mode control
- Pulse skipping for high efficiency at light loads
- Internal soft-start
- Thermal shutdown
- Short circuit protection
- Cycle by cycle current limit
- -40°C to 85°C ambient operating temperature range
- RoHS & REACH compliant
- UL94V-0 package material
- EN55022 Class B compliant

TYPICAL APPLICATIONS

- Point-of-Load from 24V, 18V, 15V, 12V, 9V rail
- Replacement for linear regulators
- Interface and microcontroller supply
- General purpose

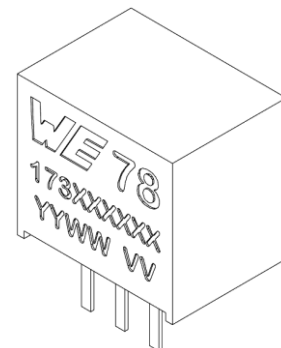

TYPICAL CIRCUIT DIAGRAM

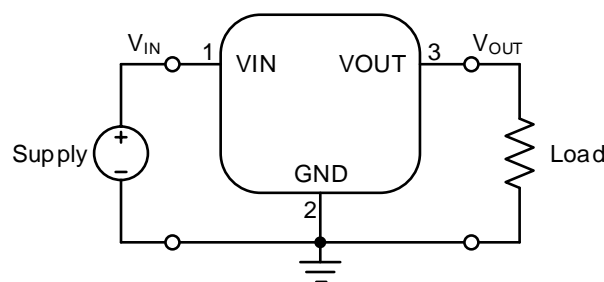

WPMDH1100xx1S / 173010x42

MagI³C Power Module
FDSM – Fixed Step Down Regulator Module

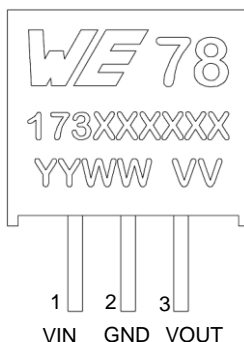
**PACKAGE****MARKING DESCRIPTION**

Marking	Description
WE	Würth Elektronik tradename
78	Indicates the compatibility with 78xx linear regulator
173xxxxxx	Ordering Code
YY	Year
WW	Calendar week
VV	Output voltage (3.3V or 5V)

PIN DESCRIPTION

SYMBOL	PIN	TYPE	DESCRIPTION
VIN	1	Power	Input voltage
GND	2	Power	Ground reference for VIN and VOUT
VOUT	3	Power	Output voltage

ORDERING INFORMATION

ORDER CODE	PART DESCRIPTION	SPECIFICATIONS	PACKAGE	PACKAGING UNIT
173010542	WPMDH1100501S	42V / 5V - 1.0A version	SIP-3	Tube with 42 pieces
173010342	WPMDH1100331S	42V / 3.3V - 1.0A version	SIP-3	Tube with 42 pieces

PIN COMPATIBLE DEVICES OF OTHER FAMILIES

ORDER CODE	PART DESCRIPTION	SPECIFICATIONS	PACKAGE	PACKAGING UNIT
173950578	WPMDL9500501S	28V / 5V - 0.5A version	SIP-3	Tube with 42 pieces
173950378	WPMDL9500501S	28V / 3.3V - 0.5A version	SIP-3	Tube with 42 pieces
173010578	WPMDL1100501S	28V / 5V - 1.0A version	SIP-3	Tube with 42 pieces
173010378	WPMDL1100331S	28V / 3.3V - 1.0A version	SIP-3	Tube with 42 pieces

WPMDH1100xx1S / 173010x42

MagI³C Power Module
FDSM – Fixed Step Down Regulator Module

**PACKAGE SPECIFICATIONS**

Weight	Flammability
2.0g	Meets UL 94 V-0

SALES INFORMATION

SALES CONTACTS
<p>Würth Elektronik eiSos GmbH & Co. KG EMC & Inductive Solutions Max-Eyth-Str. 1 74638 Waldenburg Germany Tel. +49 (0) 7942 945 0 www.we-online.com powermodules@we-online.com</p>

WPMDH1100xx1S / 173010x42

MagI³C Power Module
FDSM – Fixed Step Down Regulator Module



ABSOLUTE MAXIMUM RATINGS

Caution:

Exceeding the listed absolute maximum ratings may affect the device negatively and may cause permanent damage.

These are stress ratings only, which do not imply functional operation of the device at these or any other condition beyond those indicated under “Operation Conditions”.

SYMBOL	PARAMETER	LIMITS		UNIT
		MIN ⁽¹⁾	MAX ⁽¹⁾	
V _{IN}	Input pin voltage	0	43	V
V _{OUT}	Output pin voltage	-0.2	8	V
T _{storage}	Assembled, non-operating storage temperature	-55	125	°C
V _{ESD}	ESD Voltage (Human Body Model), according to EN61000-4-2		±2000	V

OPERATING CONDITIONS

Operating conditions are conditions under which operation of the device is intended to be functional. All values are referenced to GND.

MIN and MAX limits are valid for the recommended ambient temperature range of **-40°C to 85°C**. Typical values represents statistically the utmost probability at following conditions: V_{IN} = 24V, V_{OUT} = 3.3V (173010342), V_{OUT} = 5V (173010542), I_{OUT} = 1A unless otherwise noted.

SYMBOL	PARAMETER	MIN ⁽¹⁾	TYP ⁽²⁾	MAX ⁽¹⁾	UNIT
V _{IN}	Input voltage (173010342)	7	-	42	V
V _{IN}	Input voltage (173010542)	8	-	42	V
T _A	Ambient temperature range	-40	-	85 ⁽³⁾	°C
I _{OUT}	Nominal output current			1	A

THERMAL SPECIFICATIONS

SYMBOL	PARAMETER	TYP ⁽²⁾	UNIT
Θ _{CA}	Case to ambient thermal impedance ⁽⁴⁾	70	°C/W
T _{SD}	Thermal shutdown, junction temperature rising	150	°C

WPMDH1100xx1S / 173010x42

MagI³C Power Module FDSM – Fixed Step Down Regulator Module



ELECTRICAL SPECIFICATIONS

MIN and MAX limits are valid for the recommended ambient temperature range of **-40°C to 85°C**. Typical values represent statistically the utmost probability at the following conditions: $V_{IN} = 24V$, $V_{OUT} = 3.3V$ (173010342), $V_{OUT} = 5V$ (173010542), $I_{OUT} = 0.1$ to $1A^{(5)}$ unless otherwise specified.

SYMBOL	PARAMETER	TEST CONDITIONS	MIN ⁽¹⁾	TYP ⁽²⁾	MAX ⁽¹⁾	UNIT
Output current						
I_{OCP}	Over current protection	$V_{IN} = 12V$	2.9	3.5	-	A
Accuracy						
V_{OUT}	Line regulation	$V_{IN} = 42V, T_A = 25°C, I_{OUT} = 1A$	-	0.2	-	%
	Load regulation		-	0.4	-	%
	Total output voltage variation	$T_A = 25°C, I_{OUT} = 1A$	-	±2	±3	%
	Temperature coefficient			0.015		%/°C
	Output voltage ripple (20MHz BW limited) ⁽⁶⁾	with 10µF MLCC output capacitor	-	75	100	mV _{pp}
			-	30	-	mV _{pp}
Switching frequency						
f_{SW}	Switching frequency		280	350	420	kHz
Input current						
I_{IN}	No load input current	Operating, switching	-	1	-	mA
Undervoltage behaviour						
V_{UVLO}	Under-voltage lockout	$V_{OUT} = 3.3V, V_{IN}$ increasing	-	5.7	6.3	V
		$V_{OUT} = 3.3V, V_{IN}$ decreasing	4.4	4.9		V
		$V_{OUT} = 5V, V_{IN}$ increasing	-	7.6	8	V
		$V_{OUT} = 5V, V_{IN}$ decreasing	6.8	7.2	-	V
Efficiency						
η	Efficiency	$V_{OUT} = 3.3V, V_{IN} = 7V$	-	-	89	%
		$V_{OUT} = 3.3V, V_{IN} = 42V$	-	-	79	%
		$V_{OUT} = 5V, V_{IN} = 8V$	-	-	93	%
		$V_{OUT} = 5V, V_{IN} = 42V$	-	-	85	%
Short circuit protection						
$I_{IN,short}$	Input Current under short circuit condition at output		-	65	-	mA
Transient response						
V_{TR}	Transient Response V_{OUT} over/undershoot	$I_{OUT} =$ from 0.5A to 1A or from 1A to 0.5A	-	±75	-	mV
		$I_{OUT} =$ from 0.1A to 1A or from 1A to 0.1A	-	±200	-	mV

WPMDH1100xx1S / 173010x42

Magl³C Power Module
FDSM – Fixed Step Down Regulator Module

**EMC BEHAVIOR**

PARAMETER	TEST CONDITIONS	CLASSIFICATION
Conducted Emissions	With filter (see page 18)	Class B, according to EN55022 (see results on pages 7-8)
Radiated Emissions	With filter (see page 18)	Class B, according to EN55022 (see results on pages 7-8)

RELIABILITY

SYMBOL	PARAMETER	TEST CONDITIONS	MIN ⁽¹⁾	TYP ⁽³⁾	MAX ⁽¹⁾	UNIT
MTBF	Mean Time Between Failures, according to MIL-HDBK 217F	T _A = 25°C	8600 · 10 ³			h
		T _A = 68°C	3880 · 10 ³			

NOTES

- (1) Min and Max limits are 100% production tested at 25°C. Limits over the operating temperature range are guaranteed through correlation using Statistical Quality Control (SQC) methods.
- (2) Typical numbers are valid at 25°C ambient temperature and represent statistically the utmost probability assuming the Gaussian distribution.
- (3) Depending on load current, see derating diagram
- (4) Measured without heatsink, no air flow
- (5) Under light load conditions the devices may not meet all specifications
- (6) The industry standard for comparison of the output voltage ripple between switching regulators or modules requires a 10µF ceramic (sometimes additional 1µF ceramic in parallel) at the point of load where the voltage measurement is done using an oscilloscope with its probe and probe jack for low voltage/high frequency (low impedance) measurement. The oscilloscopes bandwidth is limited at 20MHz.

WPMDH1100xx1S / 173010x42

Mag³C Power Module
FDSM – Fixed Step Down Regulator Module



TYPICAL PERFORMANCE CURVES

If not otherwise specified, the following conditions apply: $T_{AMB} = 25^{\circ}\text{C}$.

EMI MEASUREMENTS

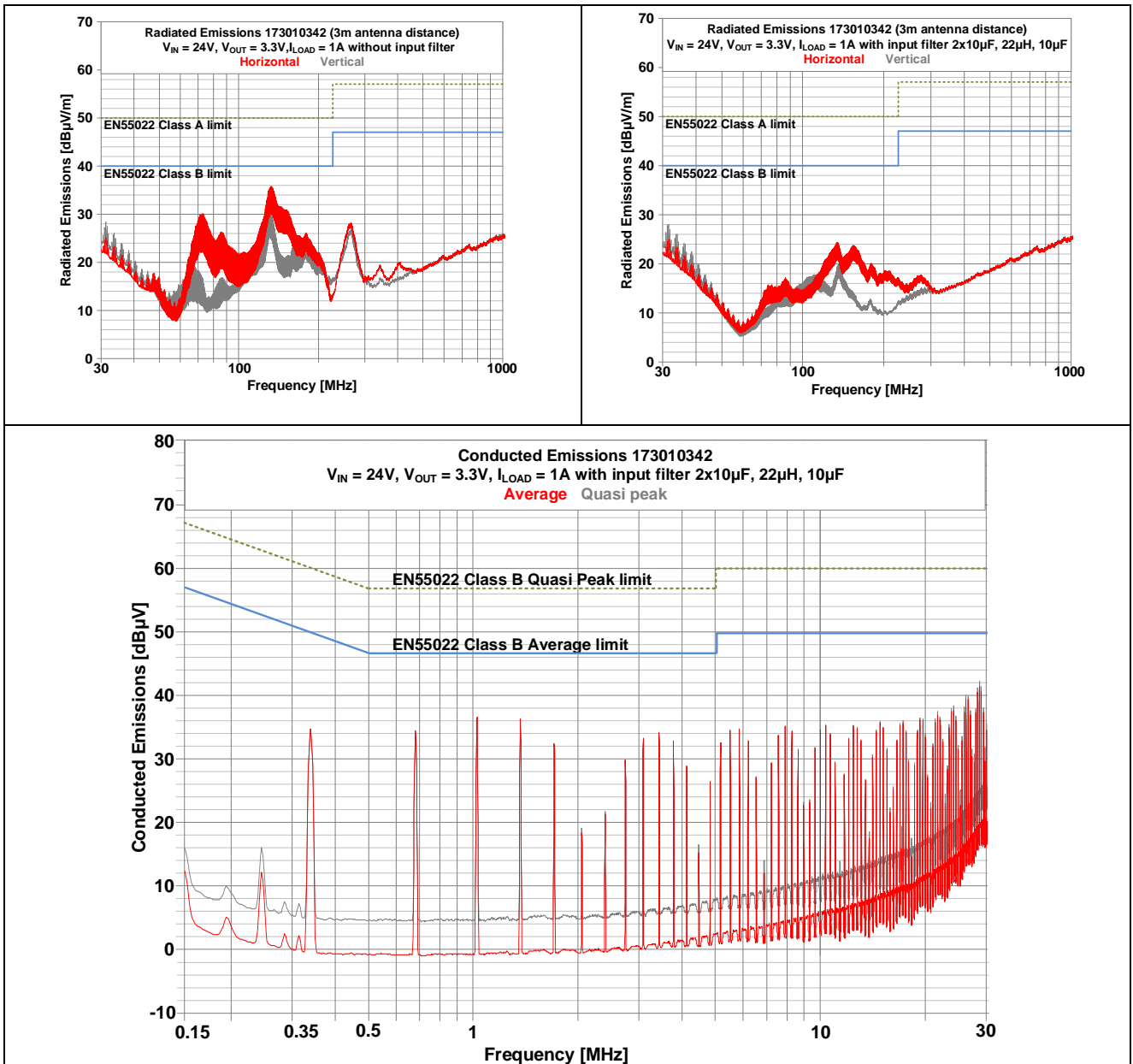

WPMDH1100xx1S / 173010x42

MagI³C Power Module
FDSM – Fixed Step Down Regulator Module



TYPICAL PERFORMANCE CURVES

If not otherwise specified, the following conditions apply: $T_{AMB} = 25^{\circ}\text{C}$.

EMI MEASUREMENTS

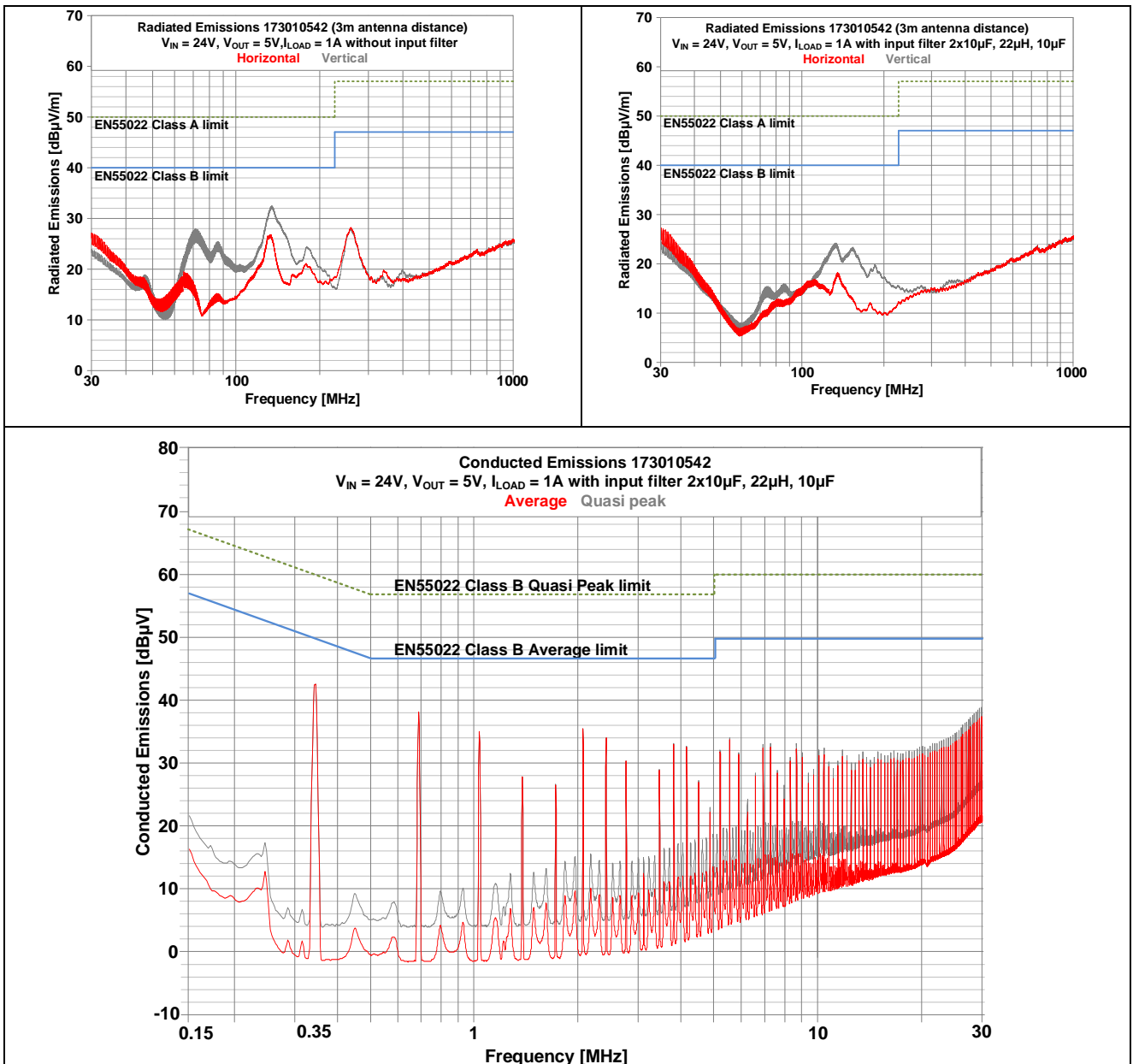

WPMDH1100xx1S / 173010x42

MagI³C Power Module
FDSM – Fixed Step Down Regulator Module



TYPICAL PERFORMANCE CURVES

If not otherwise specified, the following conditions apply: $T_{AMB} = 25^{\circ}\text{C}$.

EFFICIENCY

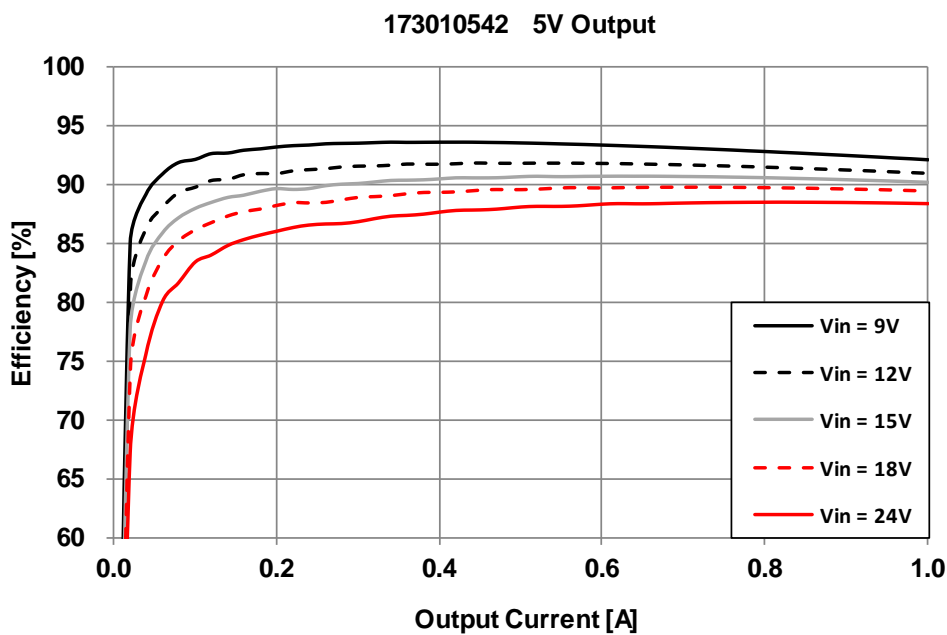
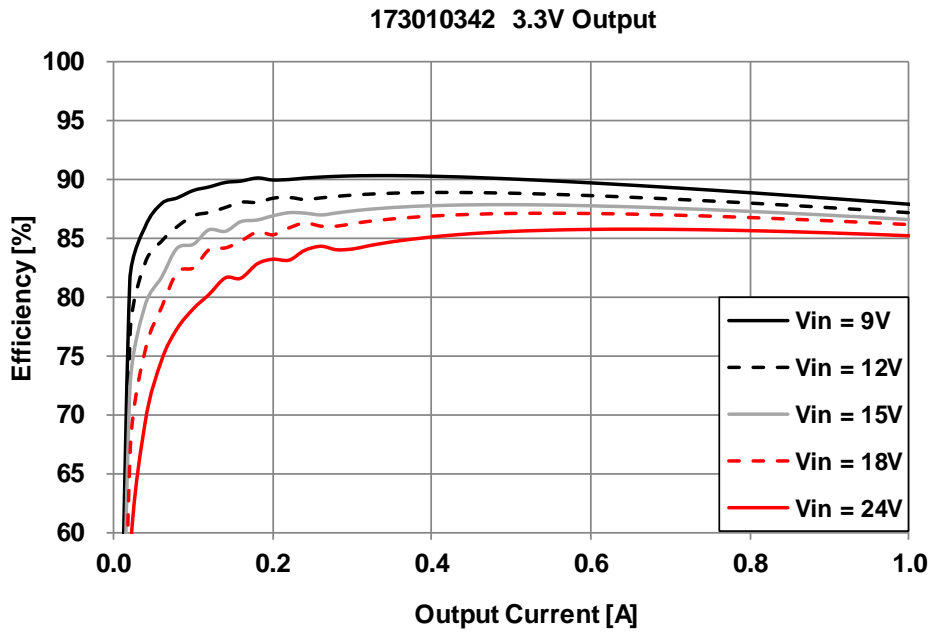

WPMDH1100xx1S / 173010x42

Magl³C Power Module
FDSM – Fixed Step Down Regulator Module



TYPICAL PERFORMANCE CURVES

If not otherwise specified, the following conditions apply: $T_{AMB} = 25^{\circ}\text{C}$.

EFFICIENCY

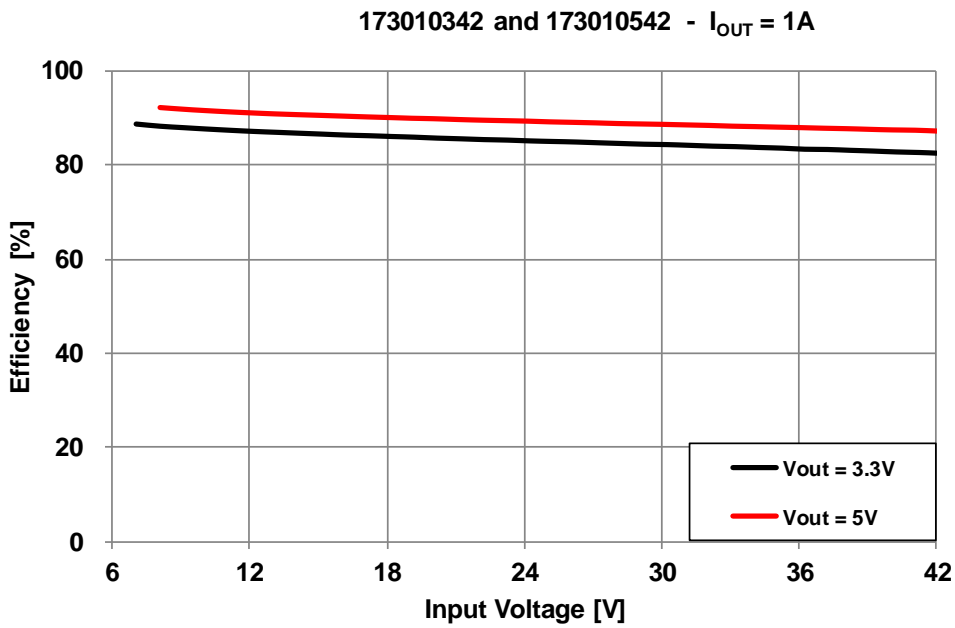

OUTPUT POWER DERATING

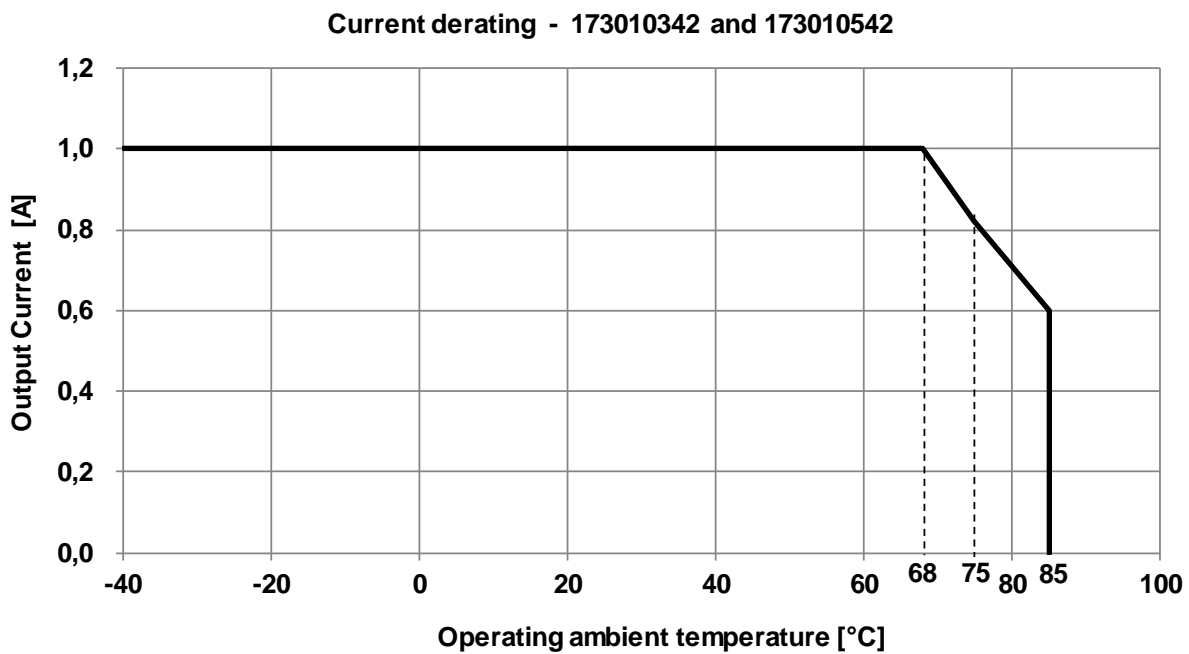

WPMDH1100xx1S / 173010x42

MagI³C Power Module
FDSM – Fixed Step Down Regulator Module



TYPICAL PERFORMANCE CURVES

If not otherwise specified, the following conditions apply: $T_{AMB} = 25^{\circ}\text{C}$.

LOAD REGULATION

173010342 3.3V Output

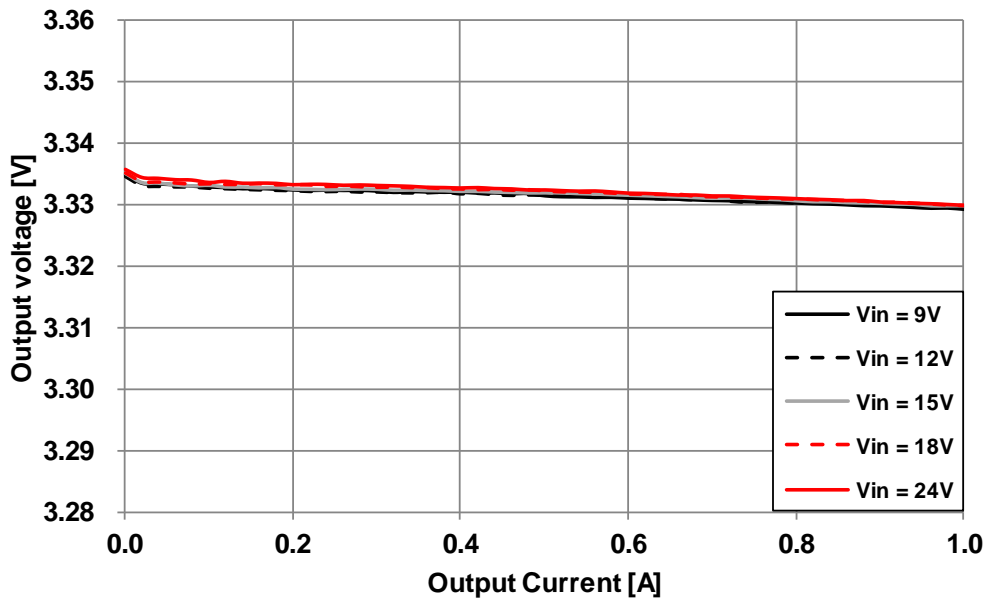

173010542 5V Output

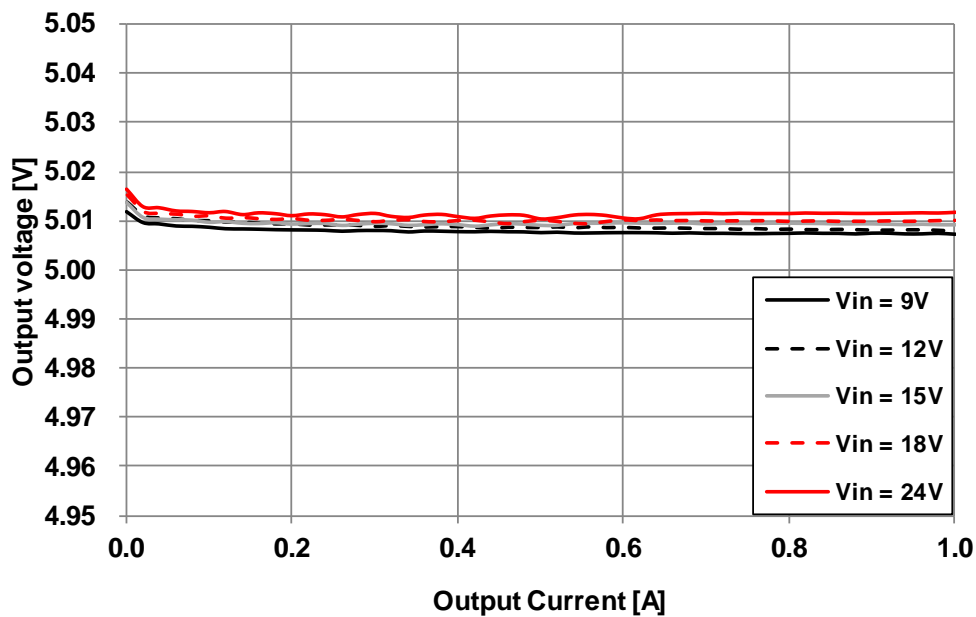

WPMDH1100xx1S / 173010x42

MagI³C Power Module
FDSM – Fixed Step Down Regulator Module



TYPICAL PERFORMANCE CURVES

If not otherwise specified, the following conditions apply: $T_{AMB} = 25^{\circ}\text{C}$.

LINE REGULATION

173010342 3.3V output

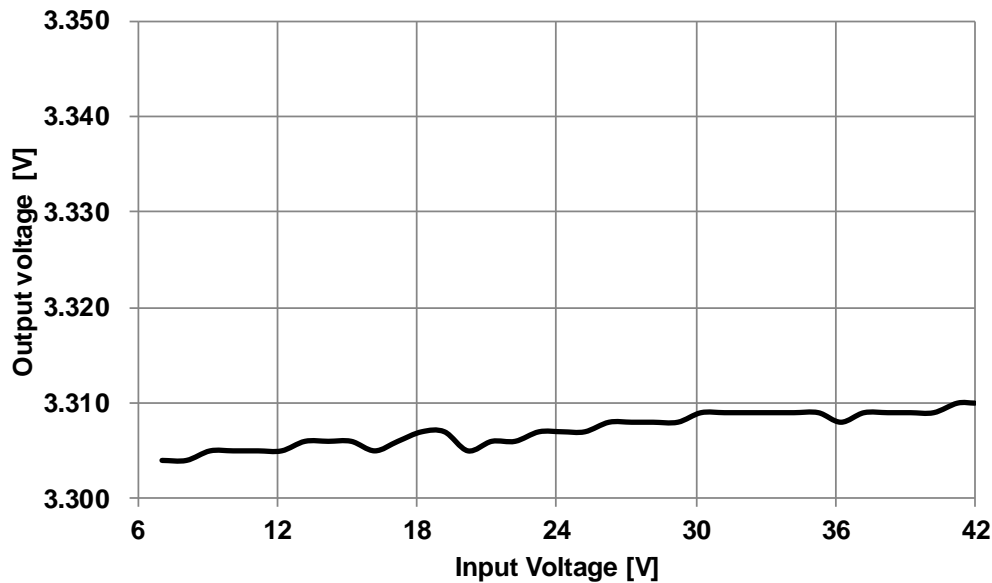

173010542 5V output

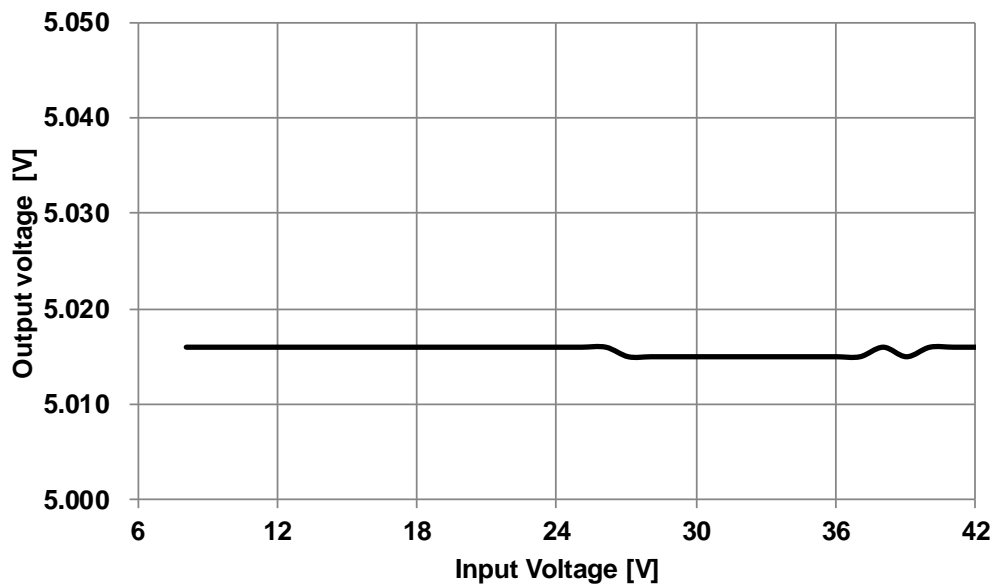

WPMDH1100xx1S / 173010x42

MagI³C Power Module
FDSM – Fixed Step Down Regulator Module



TYPICAL PERFORMANCE CURVES

If not otherwise specified, the following conditions apply: $T_{AMB} = 25^{\circ}\text{C}$.

OUTPUT VOLTAGE RIPPLE

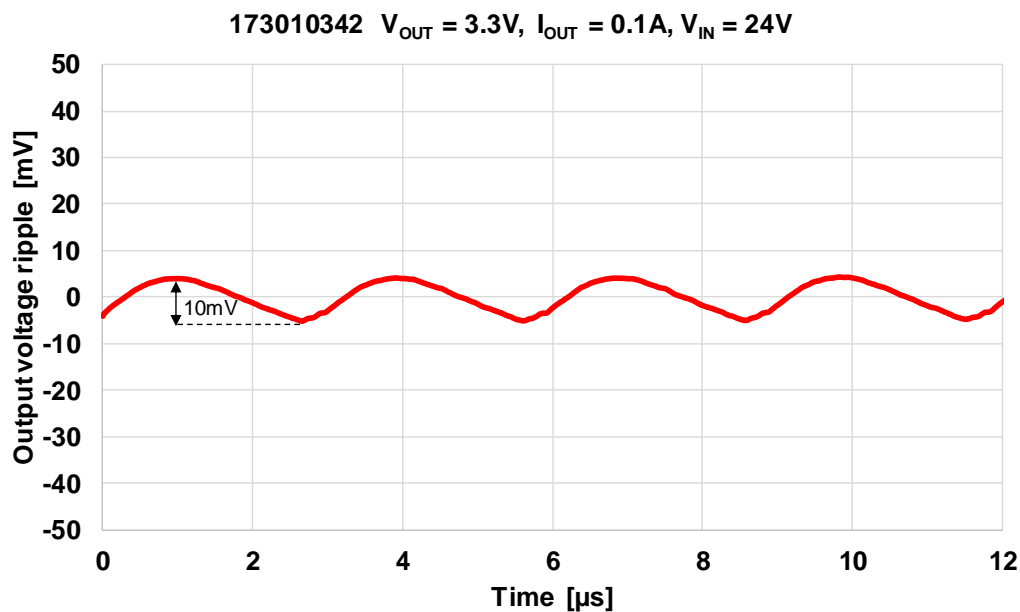
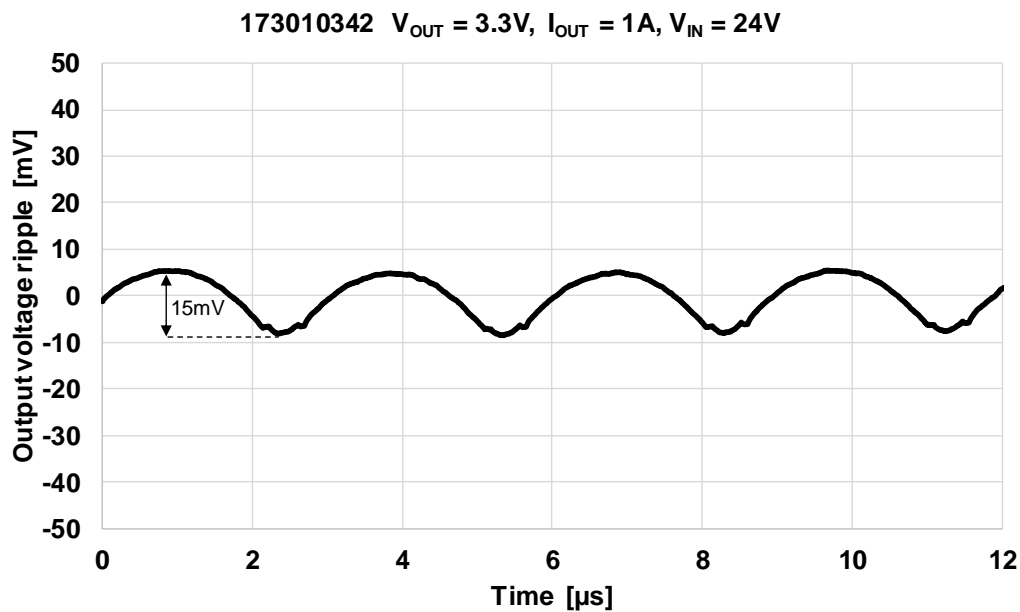

WPMDH1100xx1S / 173010x42

MagI³C Power Module
FDSM – Fixed Step Down Regulator Module



TYPICAL PERFORMANCE CURVES

If not otherwise specified, the following conditions apply: $T_{AMB} = 25^{\circ}\text{C}$.

OUTPUT VOLTAGE RIPPLE

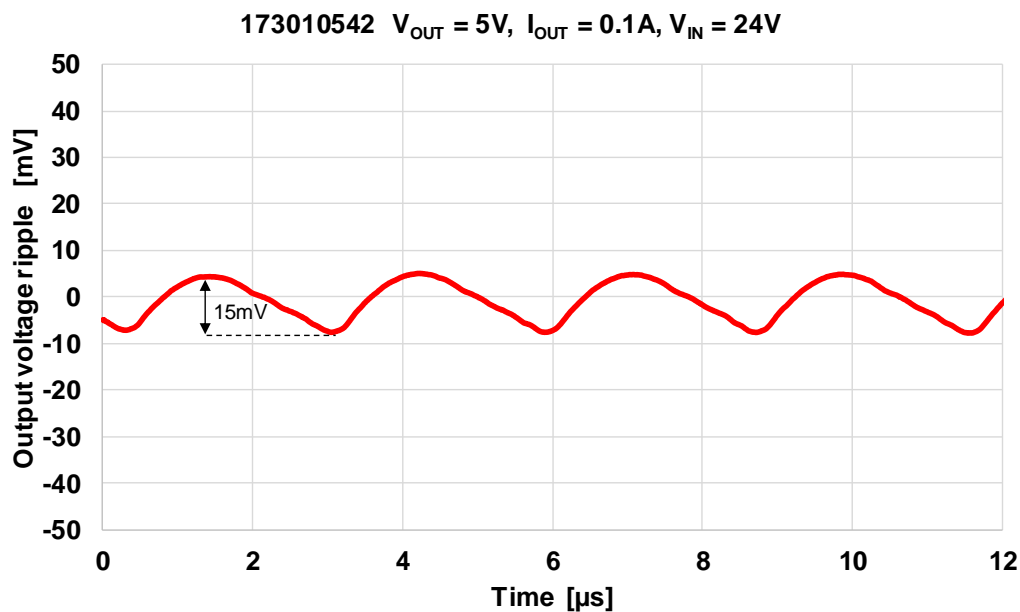
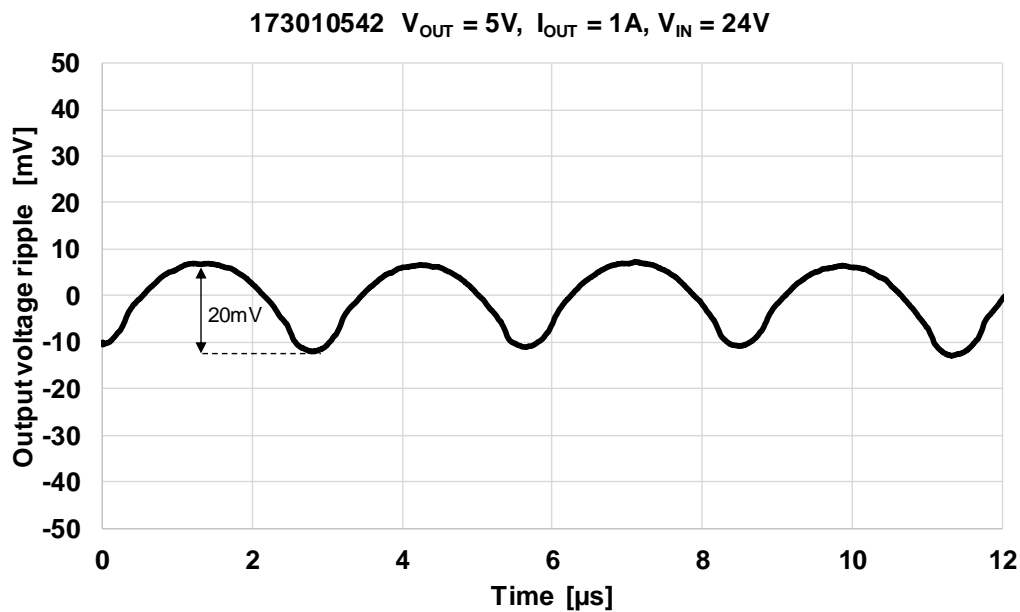

WPMDH1100xx1S / 173010x42

MagI³C Power Module
FDSM – Fixed Step Down Regulator Module



BLOCK DIAGRAM

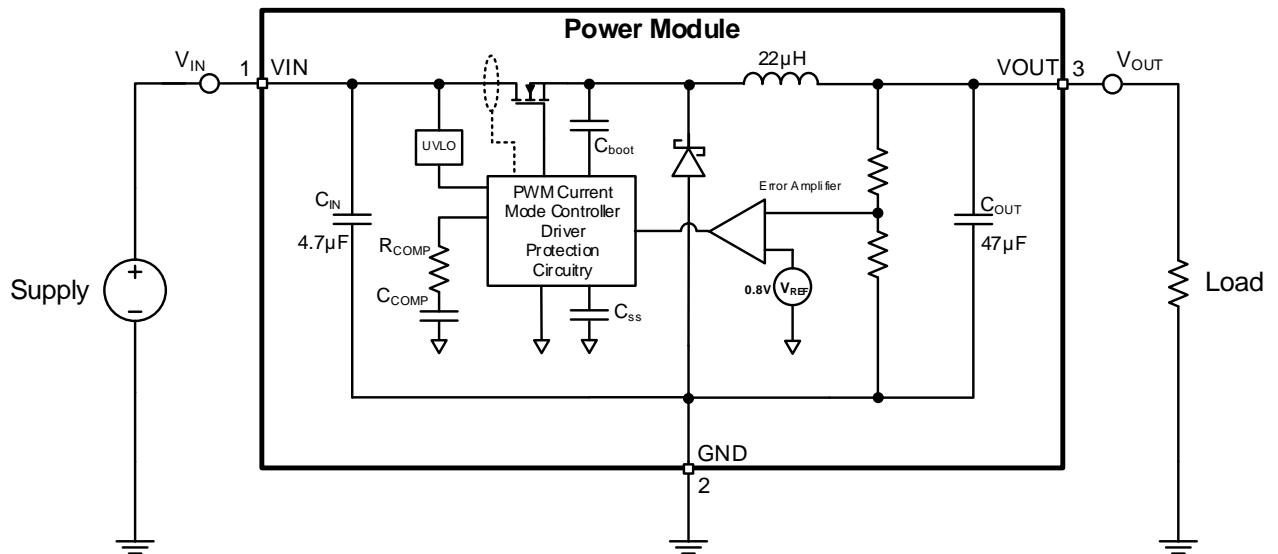

CIRCUIT DESCRIPTION

The MagI³C Power Module 17301xx42 is based on a non-synchronous step-down regulator with integrated MOSFET, free-wheeling diode, power inductor, input and output capacitors. The control scheme is based on a Current Mode (CM) regulation loop.

The V_{OUT} of the regulator is divided with the internal feedback resistor network and fed into the error amplifier which compares this signal with the internal 0.8V reference. The error signal is amplified and controls the on-time of a fixed frequency pulse width generator. This signal drives the power MOSFET.

The Current Mode architecture features a constant frequency during load steps. Only the on-time is modulated. It is internally compensated and stable.

WPMDH1100xx1S / 173010x42

MagI³C Power Module
FDSM – Fixed Step Down Regulator Module



LIGHT LOAD OPERATION

At light load conditions, the device skips switching cycles in order to keep the output voltage regulated as well as to increase the efficiency under this condition.

SOFT-START

In order to prevent the output voltage from overshooting during start-up, a soft-start is implemented. The soft-start is internally set and lasts around 1.3ms for both the 173010342 and 173010542. The figure below shows a start-up example, in this case with 173010342.

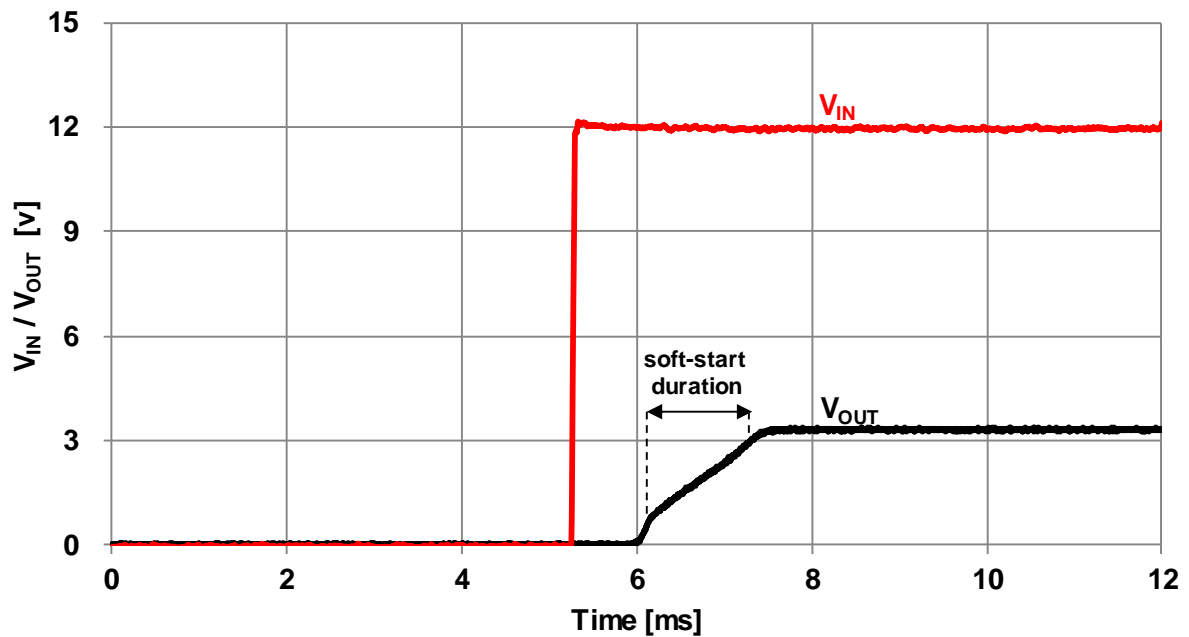

WPMDH1100xx1S / 173010x42

MagI³C Power Module
FDSM – Fixed Step Down Regulator Module



PROTECTIVE FEATURES

Over temperature protection (OTP)

The junction temperature of the MagI³C Power Module should not be allowed to exceed its maximum ratings. Thermal protection is implemented by an internal Thermal Shutdown circuit which activates at 150°C (typ.), causing the device to enter a low power standby state. In this state the MOSFET remains off causing V_{OUT} to fall. Thermal protection helps to prevent catastrophic failures from accidental device overheating. When the junction temperature falls back below 150° (hysteresis is implemented) V_{OUT} rises smoothly and normal operation resumes.

Short circuit protection (SCP)

The short circuit protection is realized via cycle by cycle current monitoring. Recovery from short circuit protection mode occurs during the switching cycle following the removal of the short circuit condition. When the 173010x42 recovers from a short circuit condition, the soft-start is not active. Therefore an overshoot at output voltage can be observed (see figure below). Under short circuit condition the input current is limited to $I_{IN,short}$ (typ. 65mA)

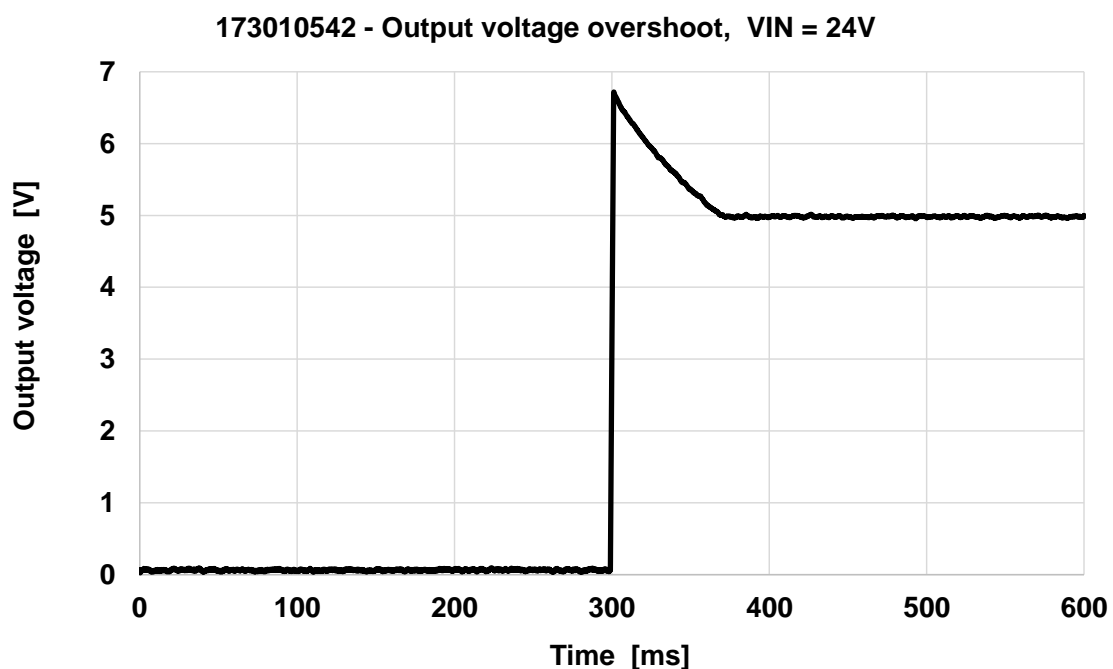

Over current protection (OCP)

For protection against load faults, the 173010x42 incorporates cycle-by-cycle current monitoring. During an overcurrent condition the output current is limited and the output voltage drops. When the overcurrent condition is removed, the output voltage returns to the nominal voltage.

WPMDH1100xx1S / 173010x42

Magl³C Power Module
FDSM – Fixed Step Down Regulator Module



APPLICATION CONSIDERATIONS

Input filter suggestion for conducted EMI

The input filter shown in the schematic below is recommended to achieve conducted EMI compliance according to EN55022 Class B (see results on pages 21 and 22).

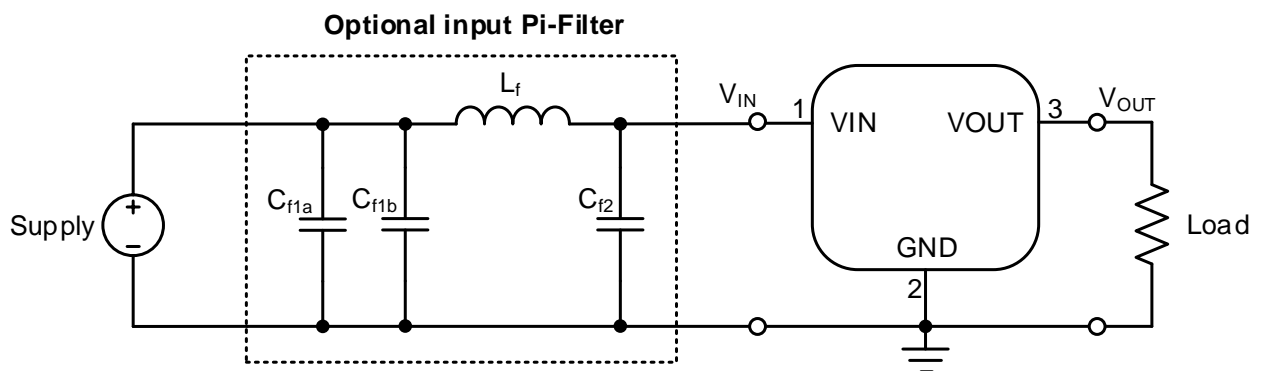

Bill of Material of the Pi-Filter

Designator	Description	Quantity	Order Code	Manufacturer
C_{f1a}	Filter ceramic chip capacitor 10 μ F/50V 1206 X5R	1		
C_{f1b}	Filter ceramic chip capacitor 10 μ F/50V 1206 X5R	1		
C_{f2}	Filter ceramic chip capacitor 10 μ F/50V 1206 X5R	1		
L_f	Filter inductor, 22 μ H, PD2 family	1	744774122	Würth Elektronik

WPMDH1100xx1S / 173010x42

MagI³C Power Module
FDSM – Fixed Step Down Regulator Module



Generating negative output voltage

Many industrial applications require negative voltages. The 173010x42 can easily provide a negative voltage using the circuit shown below.

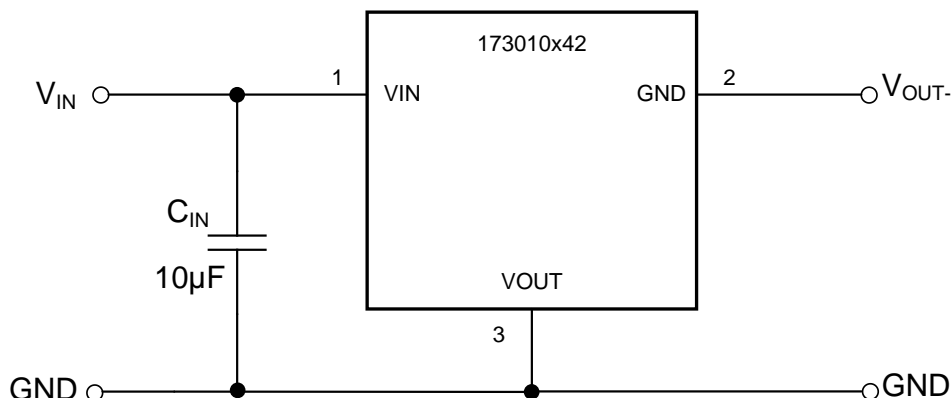

It is important to be aware that in this configuration the 173010x42 must withstand the sum of the input voltage and the absolute value of the output voltage ($V_{IN} + |V_{OUT}|$), instead of just the input voltage. This means that the maximum operating voltage should be limited to $42V - |V_{OUT}|$ (e.g. if the 171010542 is used in this configuration, the input voltage should not exceed 37V). Moreover, the maximum output current of this configuration is no longer 1A, instead it must be reduced according to the below mentioned formula (see also the graph below):

$$I_{OUT-} = (1 - D) \cdot 1A \quad (1)$$

where D is the duty cycle, in this case defined according to:

$$D = \frac{V_{OUT}}{V_{IN} + V_{OUT}} \quad (2)$$

WPMDH1100xx1S / 173010x42

MagI³C Power Module
FDSM – Fixed Step Down Regulator Module

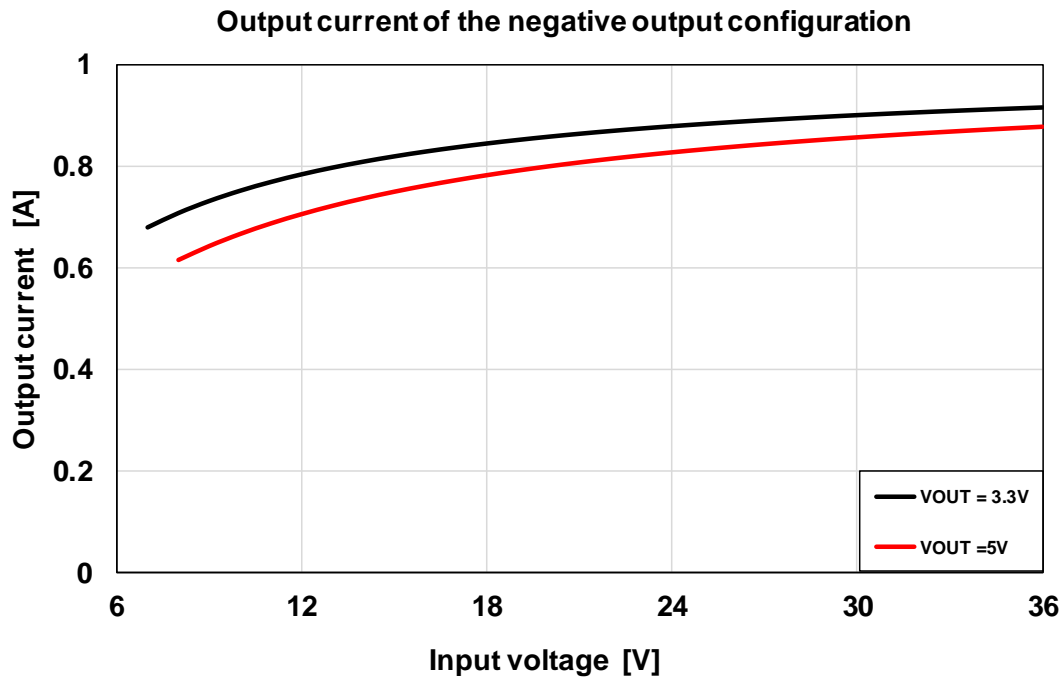

Compared with a standard positive buck configuration, the negative output buck contains an additional critical loop (between V_{IN} and V_{OUT}), which needs an additional capacitor, as shown in the circuit above.

WPMDH1100xx1S / 173010x42

MagI³C Power Module
FDSM – Fixed Step Down Regulator Module



Another common requirement in industrial application is to provide a complementary voltage (e.g. $\pm 5V$). The circuit below shows how this target can be achieved simply combining a 173010x42 used in a standard configuration (delivering a positive output voltage) with the above mentioned solution for negative voltages.

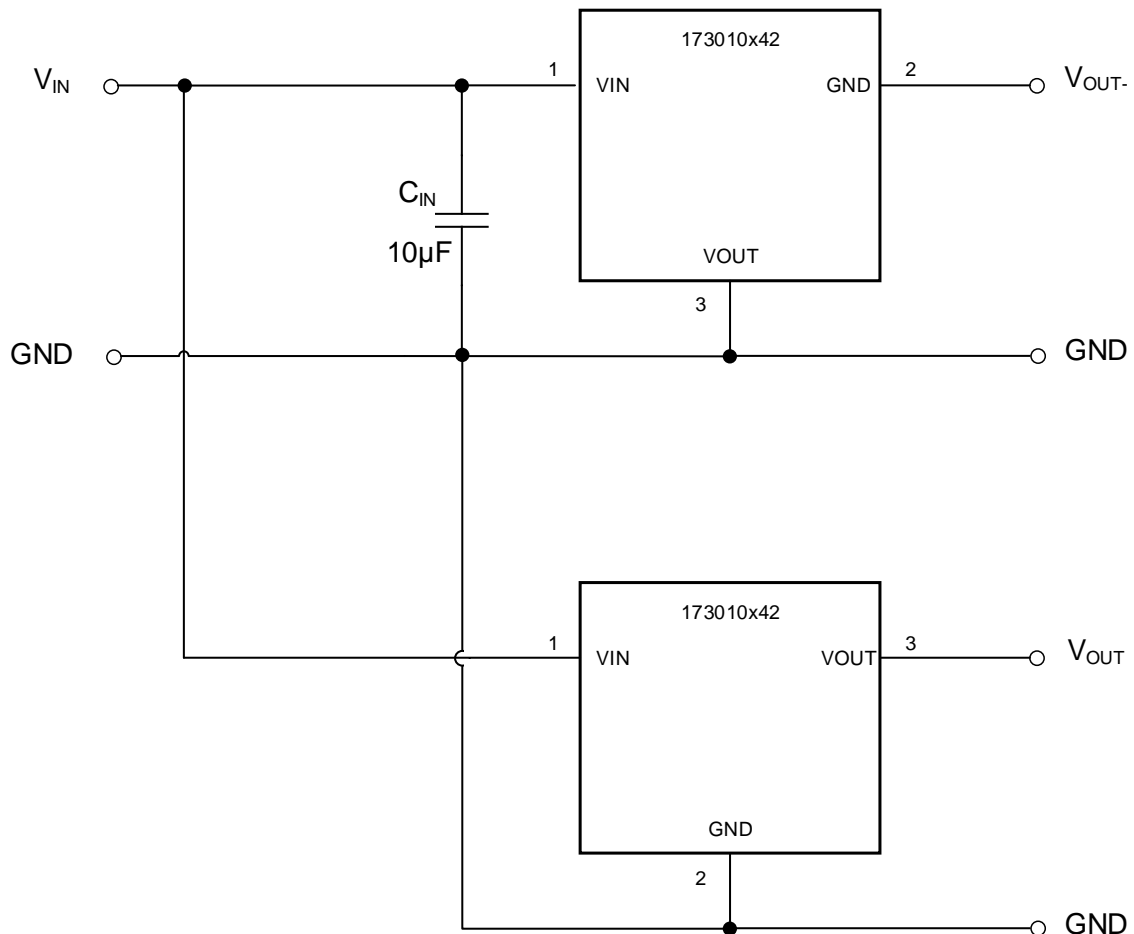

Complementary output voltage

WPMDH1100xx1S / 173010x42

MagI³C Power Module
FDSM – Fixed Step Down Regulator Module



PHYSICAL DIMENSIONS

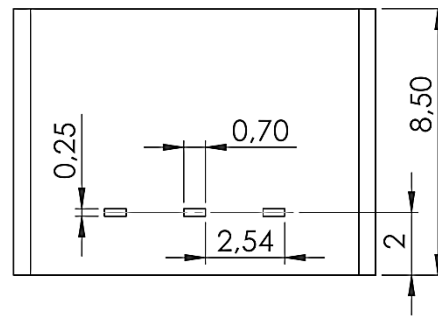
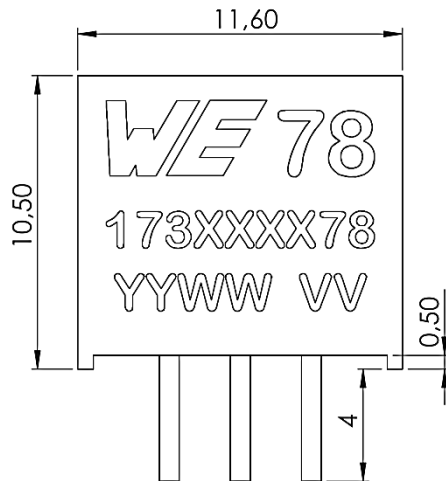

Tolerance: xx.x = ±0.5mm ; xx.xx = ±0.25mm

RECOMMENDED DRILL HOLES

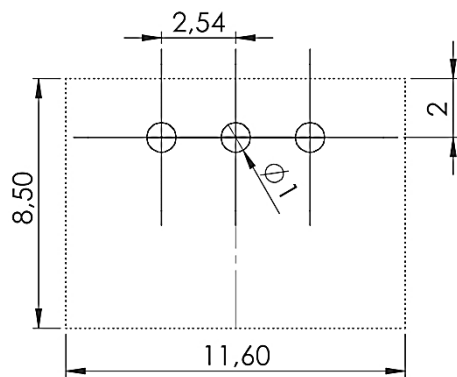

TUBE

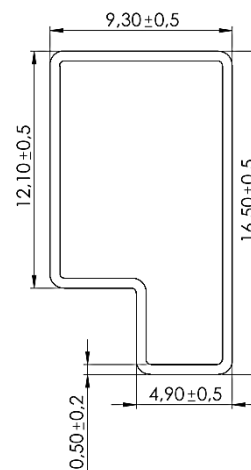

all dimensions in mm

WPMDH1100xx1S / 173010x42**MagI³C Power Module**
FDSM – Fixed Step Down Regulator Module**DOCUMENT HISTORY**

Revision	Date	Description	Comment
1.0	June 2016	Final version	

CAUTIONS AND WARNINGS

The following conditions apply to all goods within the product series of MagI³C of Würth Elektronik eiSos GmbH & Co. KG:

General:

All recommendations according to the general technical specifications of the data-sheet have to be complied with.

The usage and operation of the product within ambient conditions which probably alloy or harm the component surface has to be avoided.

The responsibility for the applicability of customer specific products and use in a particular customer design is always within the authority of the customer. All technical specifications for standard products do also apply for customer specific products.

Residual washing varnish agent that is used during the production to clean the application might change the characteristics of the body, pins or termination. The washing varnish agent could have a negative effect on the long term function of the product. Direct mechanical impact to the product shall be prevented as the material of the body, pins or termination could flake or in the worst case it could break. As these devices are sensitive to electrostatic discharge customer shall follow proper IC Handling Procedures.

Customer acknowledges and agrees that it is solely responsible for compliance with all legal, regulatory and safety-related requirements concerning its products, and any use of Würth Elektronik eiSos GmbH & Co. KG components in its applications, notwithstanding any applications-related information or support that may be provided by Würth Elektronik eiSos GmbH & Co. KG. Customer represents and agrees that it has all the necessary expertise to create and implement safeguards which anticipate dangerous consequences of failures, monitor failures and their consequences lessen the likelihood of failures that might cause harm and take appropriate remedial actions. Customer will fully indemnify Würth Elektronik eiSos and its representatives against any damages arising out of the use of any Würth Elektronik eiSos GmbH & Co. KG components in safety-critical applications.

Product specific:

Follow all instructions mentioned in the datasheet, especially:

- The solder profile has to comply with the technical reflow or wave soldering specification, otherwise this will void the warranty.
- All products are supposed to be used before the end of the period of 12 months based on the product date-code.
- Violation of the technical product specifications such as exceeding the absolute maximum ratings will void the warranty.
- It is also recommended to return the body to the original moisture proof bag and reseal the moisture proof bag again.
- ESD prevention methods need to be followed for manual handling and processing by machinery.

WPMDH1100xx1S / 173010x42

Magl³C Power Module FDSM – Fixed Step Down Regulator Module



IMPORTANT NOTES

The following conditions apply to all goods within the product range of Würth Elektronik eiSos GmbH & Co. KG:

1. General Customer Responsibility

Some goods within the product range of Würth Elektronik eiSos GmbH & Co. KG contain statements regarding general suitability for certain application areas. These statements about suitability are based on our knowledge and experience of typical requirements concerning the areas, serve as general guidance and cannot be estimated as binding statements about the suitability for a customer application. The responsibility for the applicability and use in a particular customer design is always solely within the authority of the customer. Due to this fact it is up to the customer to evaluate, where appropriate to investigate and decide whether the device with the specific product characteristics described in the product specification is valid and suitable for the respective customer application or not. Accordingly, the customer is cautioned to verify that the datasheet is current before placing orders.

2. Customer Responsibility related to Specific, in particular Safety-Relevant Applications

It has to be clearly pointed out that the possibility of a malfunction of electronic components or failure before the end of the usual lifetime cannot be completely eliminated in the current state of the art, even if the products are operated within the range of the specifications. In certain customer applications requiring a very high level of safety and especially in customer applications in which the malfunction or failure of an electronic component could endanger human life or health it must be ensured by most advanced technological aid of suitable design of the customer application that no injury or damage is caused to third parties in the event of malfunction or failure of an electronic component.

3. Best Care and Attention

Any product-specific notes, warnings and cautions must be strictly observed.

4. Customer Support for Product Specifications

Some products within the product range may contain substances which are subject to restrictions in certain jurisdictions in order to serve specific technical requirements. Necessary information is available on request. In this case the field sales engineer or the internal sales person in charge should be contacted who will be happy to support in this matter.

5. Product R&D

Due to constant product improvement product specifications may change from time to time. As a standard reporting procedure of the Product Change Notification (PCN) according to the JEDEC-Standard we inform about minor and major changes. In case of further queries regarding the PCN, the field sales engineer or the internal sales person in charge should be contacted. The basic responsibility of the customer as per Section 1 and 2 remains unaffected.

6. Product Life Cycle

Due to technical progress and economical evaluation we also reserve the right to discontinue production and delivery of products. As a standard reporting procedure of the Product Termination Notification (PTN) according to the JEDEC-Standard we will inform at an early stage about inevitable product discontinuance. According to this we cannot guarantee that all products within our product range will always be available. Therefore it needs to be verified with the field sales engineer or the internal sales person in charge about the current product availability expectancy before or when the product for application design-in disposal is considered. The approach named above does not apply in the case of individual agreements deviating from the foregoing for customer-specific products.

7. Property Rights

All the rights for contractual products produced by Würth Elektronik eiSos GmbH & Co. KG on the basis of ideas, development contracts as well as models or templates that are subject to copyright, patent or commercial protection supplied to the customer will remain with Würth Elektronik eiSos GmbH & Co. KG. Würth Elektronik eiSos GmbH & Co. KG does not warrant or represent that any license, either expressed or implied, is granted under any patent right, copyright, mask work right, or other intellectual property right relating to any combination, application, or process in which Würth Elektronik eiSos GmbH & Co. KG components or services are used.

8. General Terms and Conditions

Unless otherwise agreed in individual contracts, all orders are subject to the current version of the "General Terms and Conditions of Würth Elektronik eiSos Group", last version available at www.we-online.com.