

Product Overview

The TQP200002 ESD protection device is fabricated in GaAs MESFET technology and has been especially developed for high frequency applications. It delivers bi-directional protection with very low leakage currents and extremely low capacitance. It is ideally suited for cellular handsets, cordless phones, and broadband applications like CATV set top boxes and LNBS.



1.2 mm x 1.5 mm SMT

Functional Block Diagram

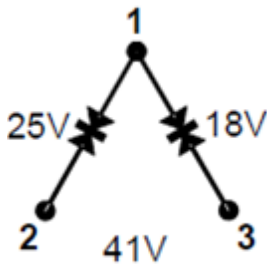

Key Features

- Snap-Back ESD protection
- Low clamp voltages 15 or 30 V
- Low trigger voltages 18, 25, or 41 V
- Two bidirectional protection lines
- Fast response time: under 1 ns
- Low capacitance: 0.22 pF
- Thin Small Leadless SMT Package (A=1.8 mm²)

Snap Back Characteristics

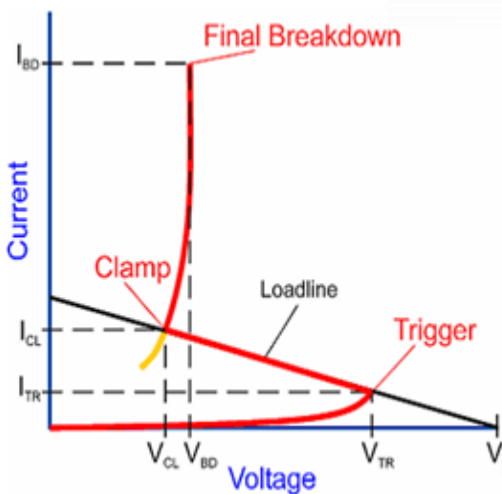

Applications

- Cellular Handsets
- Cordless Phone
- LNBS
- CATV set top boxes

Ordering Information

Part Number	Description
TQP200002	13-inch reel with 10,000 pieces
TQP200002SR	7-inch reel with 100 pieces

Absolute Maximum Ratings

Parameter	Rating
Supply Voltage (V_{DD})	+25 V
Total Power Dissipation	+600 mW
IEC 61000-4-2 Air Discharge	+3000 V
IEC 61000-4-2 Contact Discharge	+3000 V
JEDEC Human Body Model (HBM)	+8000 V
Storage Temperature Range	-65 to +150 °C
Operating Temperature Range	-40 to +85 °C
Maximum Junction Temperature (for >10 ⁶ hours MTTF)	+160 °C

Exceeding any one or a combination of the Absolute Maximum Rating conditions may cause permanent damage to the device. Extended application of Absolute Maximum Rating conditions to the device may reduce device reliability.

Electrical Specifications

Parameter	Condition ⁽¹⁾	Min	Typ	Max	Unit
Supply Voltage (V_{D13})		-7		+7	V
Supply Voltage (V_{D12})		-7		+7	V
Supply Voltage (V_{D23})		-17		+17	V
Trigger Voltage (V_1)	P1, 3	+13	+18	+23	V
Clamp Voltage (V_{C11})	P1, 3	+10	+15	+20	V
Leakage Current (I_{leak1})	1 V		+20		nA
Leakage Current (I_{leak1})	15 V		+500		nA
Capacitance (C_1)	1 V, 10 MHz		+290		fF
Trigger Voltage (V_2)	P1, 2	+20	+25	+30	V
Clamp Voltage (V_{C12})	P1, 2	+10	+15	+20	V
Leakage Current (I_{leak2})	1 V		+20		nA
Leakage Current (I_{leak2})	15 V		+500		nA
Capacitance (C_2)	1 V, 10 MHz		+290		fF
Trigger Voltage (V_3)	P2, 3	+31	+41	+46	V
Clamp Voltage (V_{C13})	P2, 3	+20	+30	+40	V
Leakage Current (I_{leak3})	1 V		+15		nA
Leakage Current (I_{leak3})	15 V		+300		nA
Capacitance (C_3)	1 V, 10 MHz		+220		fF

Notes:

1. Typical performance at these conditions: Temp = +25 °C, 75 Ω system

Device Characterization Data

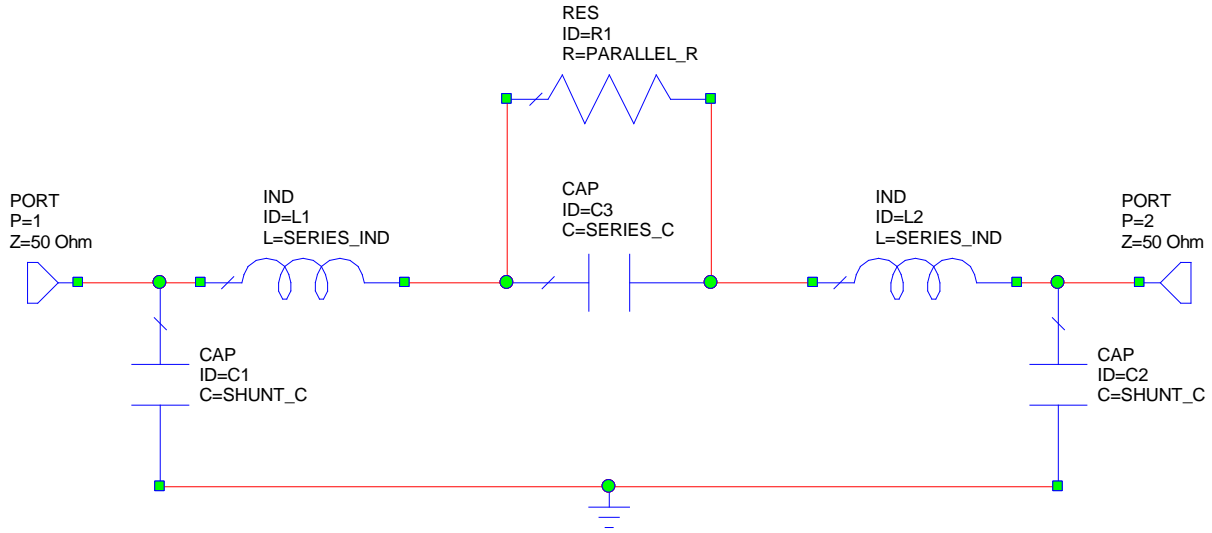

Pin 2 to Pin 3 Small Signal Element	Value	Unit
Series_C	0.22	pF
Shunt_C_In	0.08	pF
Shunt_C_Out	0.01	pF
Series_Ind	0.20	nH
Parallel_R	230	MΩ

Notes:

1. Values of input and output shunt capacitances are dependent upon the board material and the board pad sizes and will be layout dependent.

Trigger Voltage	Unit	V1 = 18 V	V2 = 25 V	V3 = 41 V
Insertion Loss	dB	0.3	0.25	0.25
Input Return Loss	dB	19	21	21
Output Return Loss	dB	19	21	21

Typical Performance: 50 – 1200 MHz

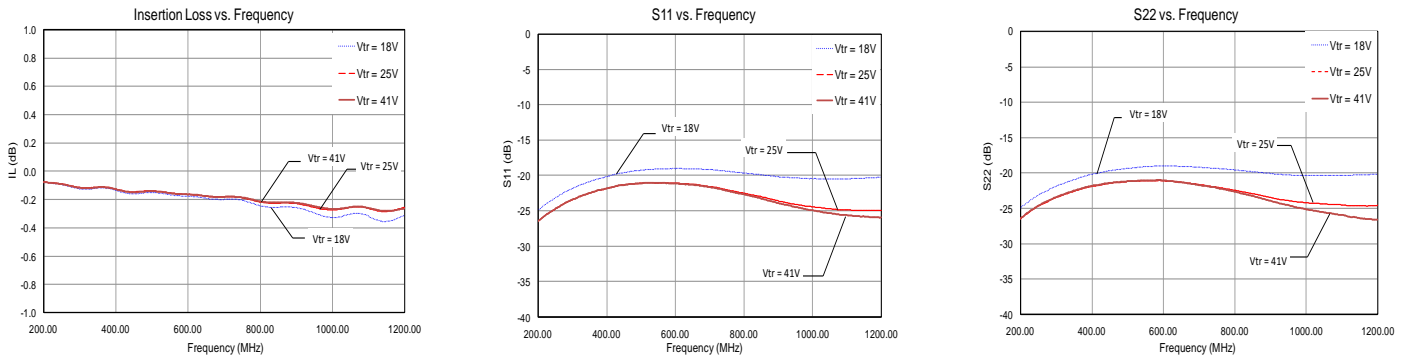

Distortion Performance: ACPR

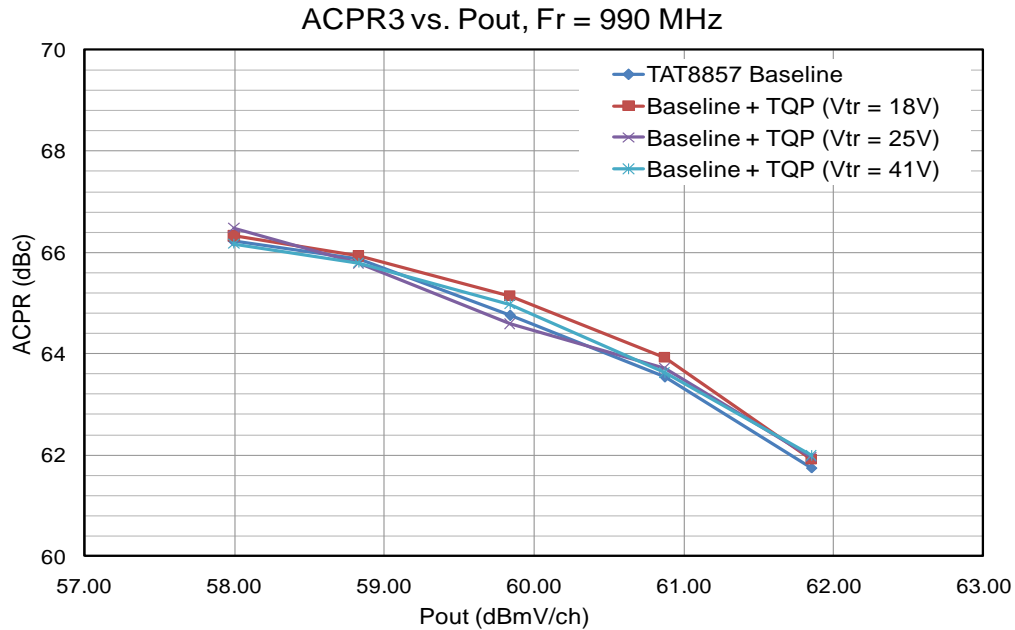

Notes:

1. ACPR data was taken against a baseline obtained for the TAT8857 at 990 MHz.
2. Channel plan: 4 combined channels, 256 QAM modulation per DOCSIS 3.0
3. ACPR3: -6 MHz from channel block edge to 12 MHz from channel block edge.

Distortion Performance: CTB/CSO

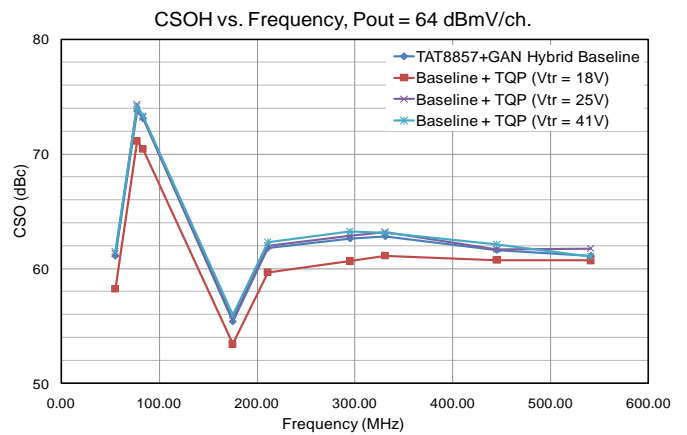
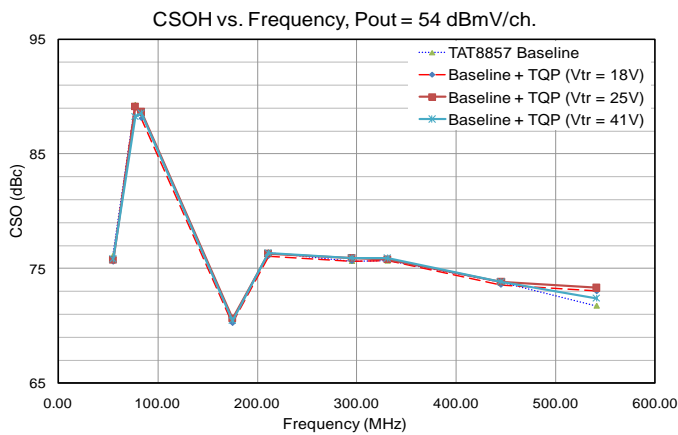
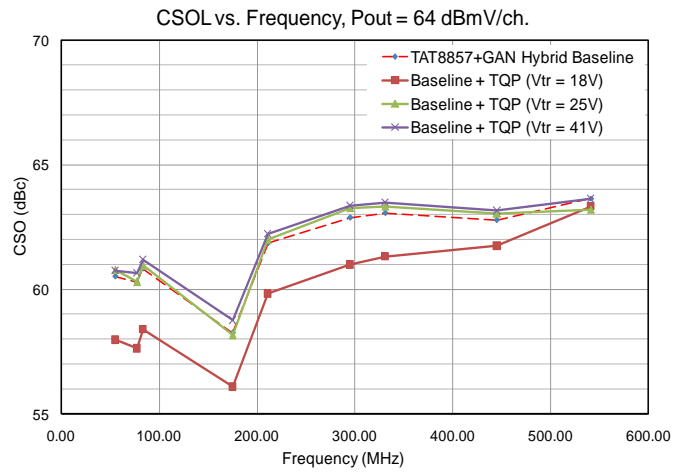
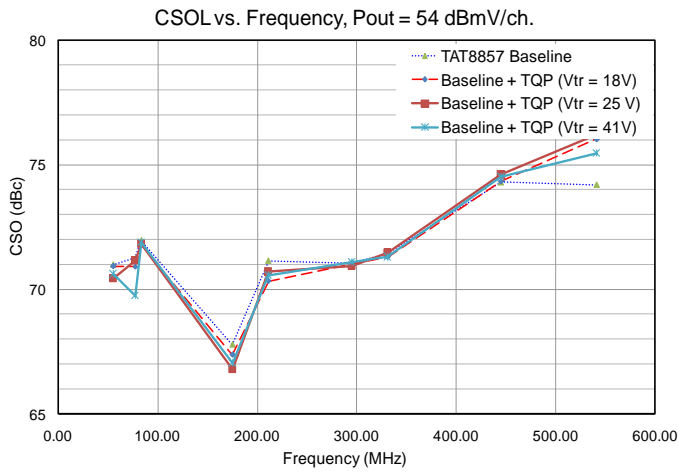
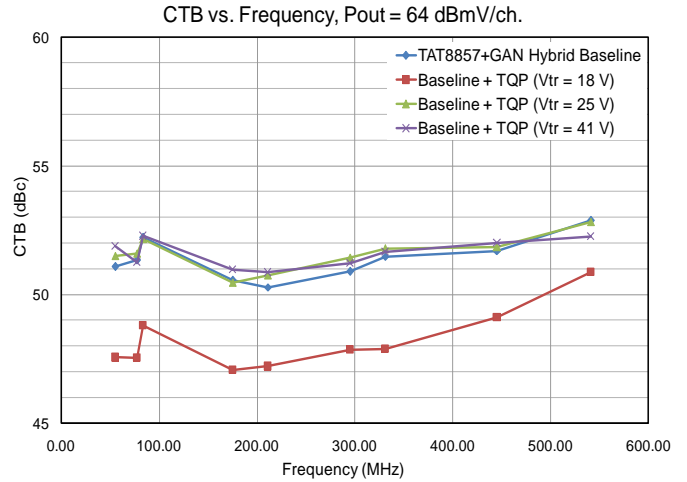
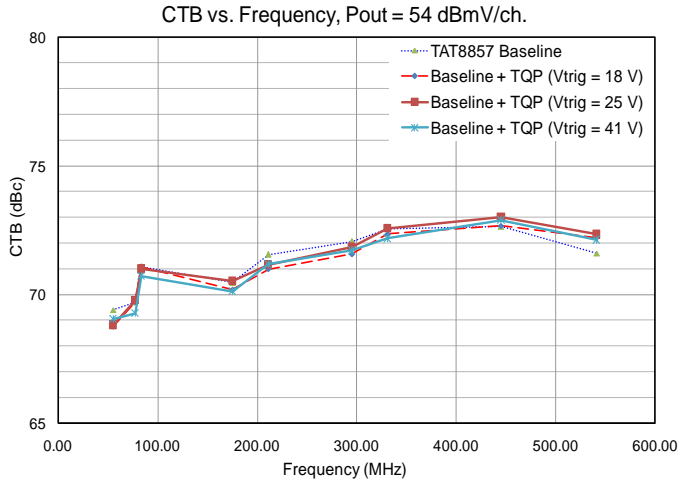

Notes:

1. Distortion data was taken against baselines obtained for the TAT8857 and an industry leading GAN module.
2. Channel plan: 79 ch NTSC + QAM to 1 GHz with 13 dB tilt at input.

Package Outline

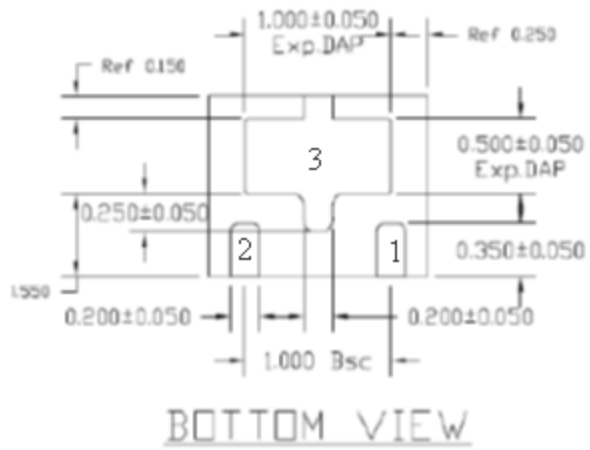
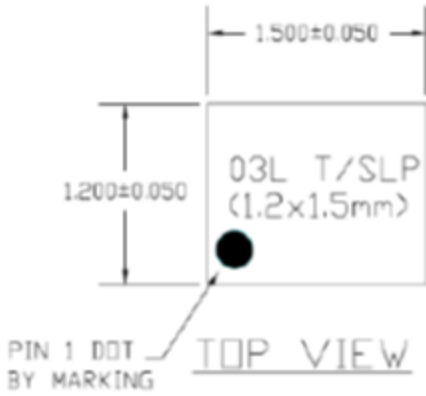

NOTE:

1) TSLP AND SLP SHARE THE SAME EXPOSED AREA
BUT WITH DIFFERENT THICKNESS:

A	TSLP	
	MAX.	0.600
NDM.	0.750	
MIN.	0.700	

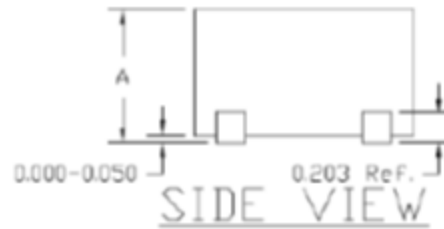

Package Marking



WHITE INK OR LASER MARK.

Line 1: XX = Last 2 digits of Qorvo assembly lot number

Tape and Reel Information

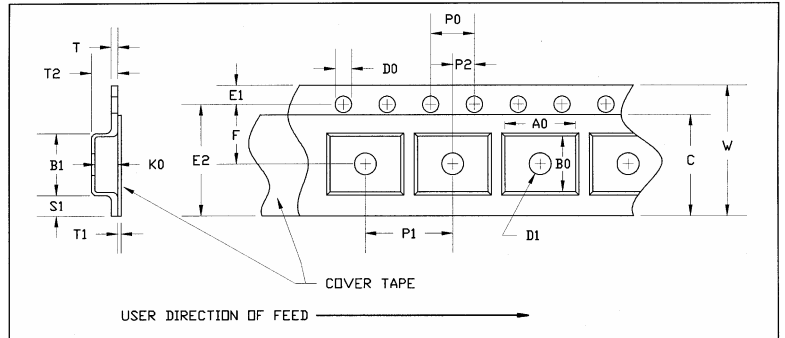

Part	Feature	Symbol	Size (in)	Size (mm)
Cavity	Length	A0	0.053	1.35
	Width	B0	0.068	1.75
	Depth	K0	0.040	1.02
	Pitch	P1	0.157	4.00
Distance Between Centerline	Cavity to Perforation	P2	0.079	2.00
	Length Direction			
	Cavity to Perforation	F	0.138	3.50
	Width Direction			
Cover Tape	Width	C	0.213	5.40
Carrier Tape	Width	W	0.315	8.00

Tape and Reel Information

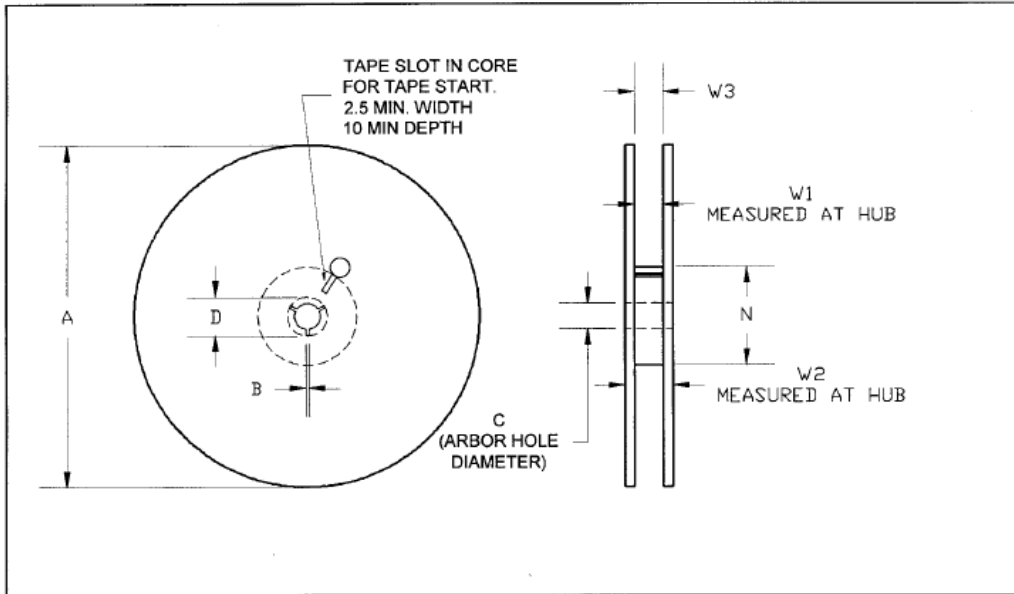

T/SLP			13" REEL	
PART	FEATURE	SYMBOL	SIZE (in)	SIZE (mm)
FLANGE	DIAMETER	A	12.992	330.0
	THICKNESS	W2	0.567	14.4
	SPACE BETWEEN FLANGE	W1	0.331	8.4
HUB	OUTER DIAMETER	N	3.937	100.0
	ARBOR HOLE DIAMETER	C	0.512	13.0
	KEY SLIT WIDTH	B	0.059	1.5
	KEY SLIT DIAMETER	D	0.795	20.2

Handling Precautions

Parameter	Rating	Standard
ESD – Human Body Model (HBM)	Class 1A	ESDA / JEDEC JS-001-2012
ESD – Charged Device Model (CDM)	Class 3B	JEDEC JESD22-C101F
MSL – Moisture Sensitivity Level	Level 1	IPC/JEDEC J-STD-020



Caution!
ESD-Sensitive Device

Solderability

Compatible with both lead-free (260 °C max. reflow temp.) and tin/lead (245 °C max. reflow temp.) soldering processes.
Solder profiles available upon request.

Contact plating: NiPdAu

RoHS Compliance

This part is compliant with 2011/65/EU RoHS directive (Restrictions on the Use of Certain Hazardous Substances in Electrical and Electronic Equipment) as amended by Directive 2015/863/EU.

This product also has the following attributes:

- Lead Free
- Halogen Free (Chlorine, Bromine)
- Antimony Free
- TBBP-A (C₁₅H₁₂Br₄O₂) Free
- PFOS Free
- SVHC Free



Important Notice

The information contained herein is believed to be reliable; however, Qorvo makes no warranties regarding the information contained herein and assumes no responsibility or liability whatsoever for the use of the information contained herein. All information contained herein is subject to change without notice. Customers should obtain and verify the latest relevant information before placing orders for Qorvo products. The information contained herein or any use of such information does not grant, explicitly or implicitly, to any party any patent rights, licenses, or any other intellectual property rights, whether with regard to such information itself or anything described by such information. **THIS INFORMATION DOES NOT CONSTITUTE A WARRANTY WITH RESPECT TO THE PRODUCTS DESCRIBED HEREIN, AND QORVO HEREBY DISCLAIMS ANY AND ALL WARRANTIES WITH RESPECT TO SUCH PRODUCTS WHETHER EXPRESS OR IMPLIED BY LAW, COURSE OF DEALING, COURSE OF PERFORMANCE, USAGE OF TRADE OR OTHERWISE, INCLUDING THE IMPLIED WARRANTIES OF MERCHANTABILITY AND FITNESS FOR A PARTICULAR PURPOSE.**

Without limiting the generality of the foregoing, Qorvo products are not warranted or authorized for use as critical components in medical, life-saving, or life-sustaining applications, or other applications where a failure would reasonably be expected to cause severe personal injury or death.

Copyright 2019 © Qorvo, Inc. | Qorvo is a registered trademark of Qorvo, Inc.

Contact Information

For the latest specifications, additional product information, worldwide sales and distribution locations:

Tel: 1-844-890-8163

Web: www.qorvo.com

Email: customer.support@qorvo.com