

Capacitive Controller ICs

# Capacitive Switch Controller IC

## BU21170MUV

### General Description

BU21170MUV is a capacitive sensor controller for switch operation.

BU21170MUV has five sensors and provides the simple switch function by each sensor.

If external noise and temperature drift are detected, the automatic self-calibration is operated.

Include LED controller with PWM function.

### Features

- 5 capacitive sensor ports.
- Automatic self-calibration.
- Continued touch detection.
- LED controller with PWM function.
- Inform the detected result of switch operation by interrupt.
- 2-wire serial bus interface.
- Single power supply.
- Built-in Power-On-Reset and Oscillator.

### Applications

- Information appliance as printer.
- AV appliance as digital TV and HDD recorder.
- Notebook PC.

### Key Specifications

- Power Supply Voltage Range: 3.0V to 5.5V
- Operating Temperature Range: -25°C to +85°C
- Operating Current: 3.5mA(Typ without load)
- Scan Rate: 14.8msec(Typ)

### Package

VQFN020V4040

W(Typ) x D(Typ) x H(Max)

4.00mm x 4.00mm x 1.00mm

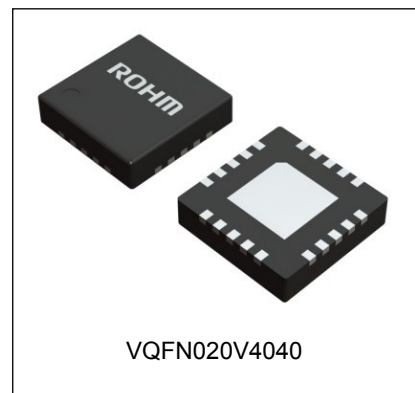

### Typical Application Circuit

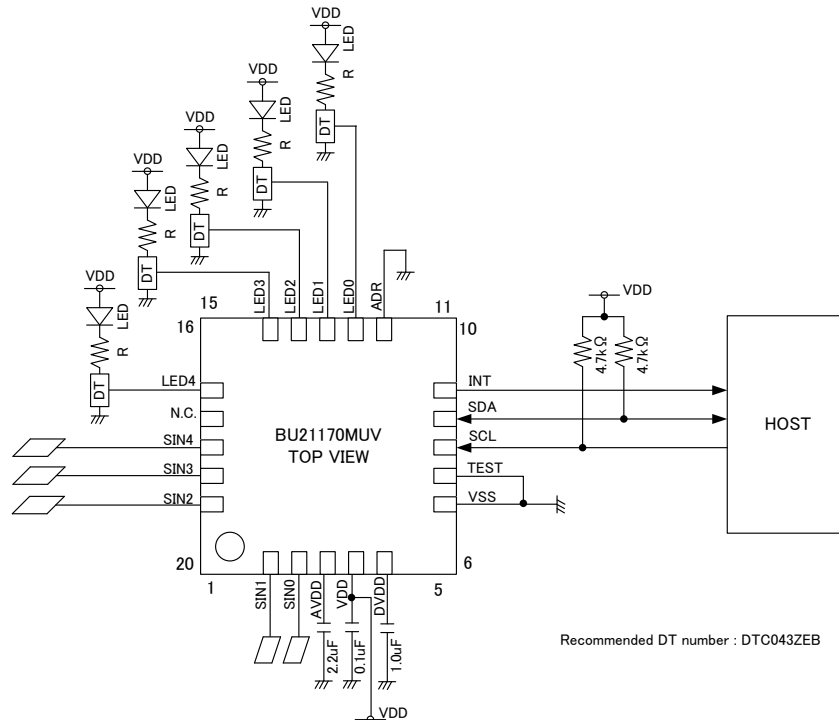

Figure 1. Typical Application Circuit

Pin Configuration

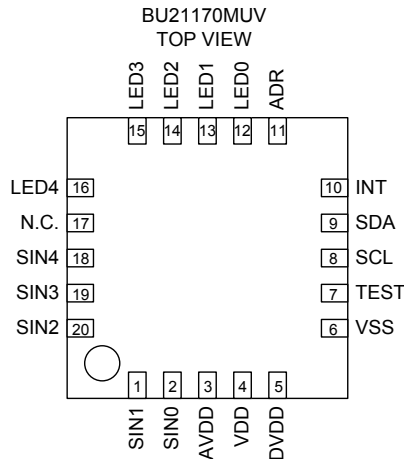

Figure 2. Pin Configuration

Pin Descriptions

Pin No.	Pin Name	Type	Function	Note	Power	Initial Condition	I/O Equivalent Circuit
1	SIN1	Ain	Capacitive touch sensor 1		AVDD	Hi-Z	Figure 3
2	SIN0	Ain	Capacitive touch sensor 0		AVDD	Hi-Z	Figure 3
3	AVDD	Power	LDO output for analog blocks		-	-	-
4	VDD	Power	Power		-	-	-
5	DVDD	Power	LDO output for digital blocks		-	-	-
6	VSS	Ground	Ground		-	-	-
7	TEST	In	Test input	Fixed 'L' at the normal operation	VDD	-	Figure 4
8	SCL	InOut	Host I/F : SCL		VDD	Hi-Z	Figure 4
9	SDA	InOut	Host I/F : SDA		VDD	Hi-Z	Figure 4
10	INT	Out	Interrupt output	Active High interrupt	VDD	'L'	Figure 5
11	ADR	In	Select slave address input	'H':0x4D , 'L':0x4C	VDD	-	Figure 4
12	LED0	Out	LED control with PWM output 0	Active High	VDD	Hi-Z	Figure 5
13	LED1	Out	LED control with PWM output 1	Active High	VDD	Hi-Z	Figure 5
14	LED2	Out	LED control with PWM output 2	Active High	VDD	Hi-Z	Figure 5
15	LED3	Out	LED control with PWM output 3	Active High	VDD	Hi-Z	Figure 5
16	LED4	Out	LED control with PWM output 4	Active High	VDD	Hi-Z	Figure 5
17	N.C.	-	-		-	-	-
18	SIN4	Ain	Capacitive touch sensor 4		AVDD	Hi-Z	Figure 3
19	SIN3	Ain	Capacitive touch sensor 3		AVDD	Hi-Z	Figure 3
20	SIN2	Ain	Capacitive touch sensor 2		AVDD	Hi-Z	Figure 3

I/O Equivalent Circuits

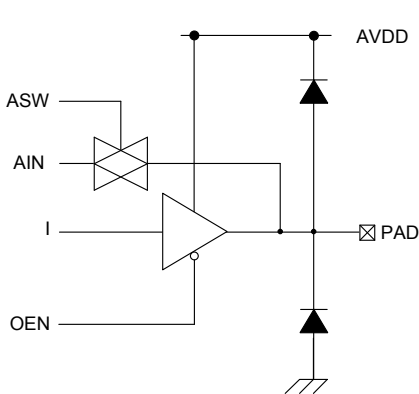

Figure 3. I/O Equivalent Circuit (a)

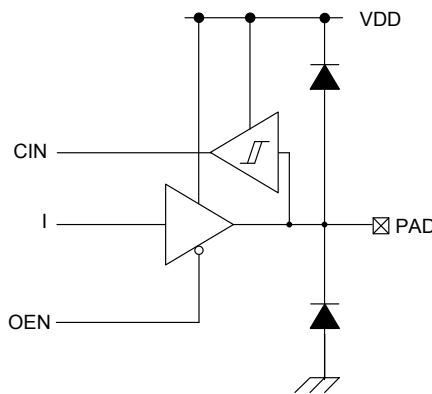

Figure 4. I/O Equivalent Circuit (b)

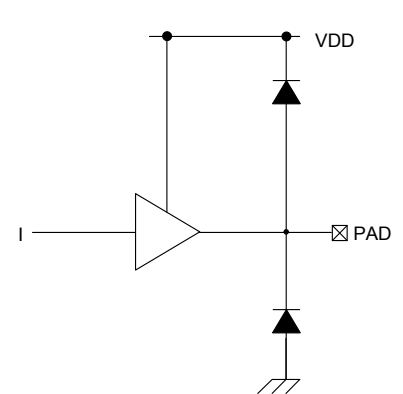

Figure 5. I/O Equivalent Circuit (c)

Block Diagram

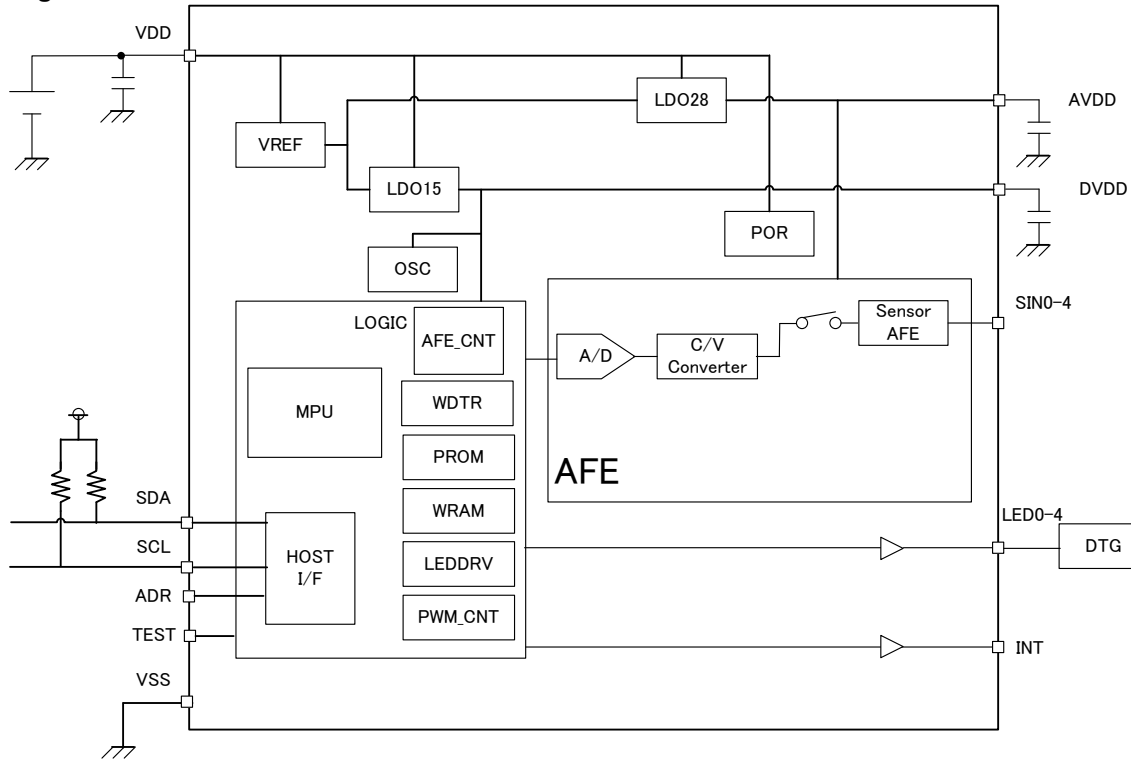

Figure 6. Block Diagram

Block Descriptions

Sensor AFE, C/V Converter

Convert from capacitance to voltage following the order of sensors.

A/D

Convert from voltage to the detected result the digital value.

LDO28

2.73V output LDO for Sensor AFE, C/V Converter and A/D.

LDO15

1.5V output LDO for OSC and digital blocks.

OSC

Ring oscillator as the system clock.

POR

Power-On-Reset monitoring VDD as the system reset.

MPU

Based on the detection result, detect switch operations (Touch/Release/Hold) and run Auto-calibration. Inform by the INT port to the host about that the switch operations are detected. LED ports are controlled by the commands from the host.

HOST I/F

2-wire serial bus interface compatible with I<sup>2</sup>C protocol. Slave address is selectable by pin ADR.

AFE\_CNT

Sequencer of Sensor AFE, C/V converter and A/D.

PWM\_CNT

PWM timers for the LED ports.

LEDDR

LED port drivers.

WDTR

Watchdog timer Timeout Reset. It releases the system reset after 0.6sec from that MPU cannot clear WDTR. (If MPU cannot clear WDTR, MPU is hung up.)

PROM

Program ROM for the included MPU.

WRAM

Work RAM for the included MPU.

## Absolute Maximum Ratings (Ta=25°C)

Parameter	Symbol	Rating	Unit
Power Supply Voltage	V <sub>DD</sub>	-0.5 to 7.0	V
Input Voltage	V <sub>IN</sub>	-0.3 to V <sub>DD</sub> +0.7	V
Power Dissipation <sup>(Note 1)</sup>	P <sub>d</sub>	0.55	W
Operating Temperature Range	T <sub>opr</sub>	-25 to +85	°C
Storage Temperature Range	T <sub>stg</sub>	-55 to +125	°C
Maximum Junction Temperature	T <sub>jmax</sub>	125	°C

(Note 1) Mounted on 74.2mm x 74.2mm x 1.6mm glass epoxy 1layer board (Copper foil area : 10.29mm<sup>2</sup>). Reduce 5.5mW per 1°C above 25°C

**Caution:** Operating the IC over the absolute maximum ratings may damage the IC. The damage can either be a short circuit between pins or an open circuit between pins and the internal circuitry. Therefore, it is important to consider circuit protection measures, such as adding a fuse, in case the IC is operated over the absolute maximum ratings.

## Recommended Operating Conditions

Parameter	Symbol	Min	Typ	Max	Unit
Power Supply Voltage	V <sub>DD</sub>	3.0	3.3	5.5	V

## Electrical Characteristics

(V<sub>DD</sub>=3.3V, V<sub>SS</sub>=0V, Ta=25°C, unless otherwise specified.)

Parameter	Symbol	Min	Typ	Max	Unit	Condition
Input High voltage	V <sub>IH</sub>	V <sub>DD</sub> × 0.7	-	V <sub>DD</sub> + 0.3	V	
Input Low voltage	V <sub>IL</sub>	V <sub>SS</sub> - 0.3	-	V <sub>DD</sub> × 0.3	V	
Output High voltage	V <sub>OH</sub>	V <sub>DD</sub> - 0.5	-	V <sub>DD</sub>	V	I <sub>OH</sub> = -4mA
Output Low voltage	V <sub>OL</sub>	V <sub>SS</sub>	-	V <sub>SS</sub> + 0.5	V	I <sub>OL</sub> = 4mA
Oscillator clock frequency	f <sub>OSC</sub>	45	50	55	MHz	
DVDD LDO output voltage	V <sub>DVDD</sub>	1.35	1.50	1.65	V	
AVDD LDO output voltage	V <sub>AVDD</sub>	2.63	2.73	2.83	V	
Power-on-reset release voltage		2.25	-	2.55	V	
Power-on-reset detect voltage		2.10	-	2.40	V	
Operating Current	I <sub>DD</sub>	-	3.5	-	mA	Without load of sensors.

Register Map

(OSC = 50MHz , unless otherwise noted)  
No accessing to the reserved areas is allowed.

Group	Address	Name	R/W	Initial	7	6	5	4	3	2	1	0	
Detected value	0x00	SIN0_DATA	R	0x00					SD_SIN0[7:0]				
	0x01	SIN1_DATA	R	0x00					SD_SIN1[7:0]				
	0x02	SIN2_DATA	R	0x00					SD_SIN2[7:0]				
	0x03	SIN3_DATA	R	0x00					SD_SIN3[7:0]				
	0x04	SIN4_DATA	R	0x00					SD_SIN4[7:0]				
	0x05-0x0D	Reserved											
Detected result	0x0E	STATE_PWM	R	0x00	-	-	-	-	PWM3	PWM2	PWM1	PWM0	
	0x0F	CONT_PWM	R	0x00	-	-	-	-	PWM3	PWM2	PWM1	PWM0	
	0x10	INTERRUPT	R	0x00	CONTDET	OFFDET	ONDET	PERCAL	PWM	ERCAL	CAL	INI	
	0x11	DETECT_ON	R	0x00	-	-	-	ON_SW4	ON_SW3	ON_SW2	ON_SW1	ON_SW0	
	0x12	DETECT_OFF	R	0x00	-	-	-	OFF_SW4	OFF_SW3	OFF_SW2	OFF_SW1	OFF_SW0	
	0x13	DETECT_CONT	R	0x00	-	-	-	CONT_SW4	CONT_SW3	CONT_SW2	CONT_SW1	CONT_SW0	
	0x14	DETECT_PWM_FINISH	R	0x00	-	-	-	-	PWM3	PWM2	PWM1	PWM0	
	0x15-0x1A	Reserved											
	0x1B	STATE_INT	R	0x00	PWM3	PWM2	PWM1	PWM0	WDT	-	AFE	I2C	
	0x1C	STATE	R	0x00	-	-	-	-	-	-	-	CALIB	
	0x1D	STATE_SIN	R	0x00	-	-	-	SIN4	SIN3	SIN2	SIN1	SIN0	
	0x1E	RACT	R	0x00					RACT[7:0]				
	0x1F	Reserved											
	-	0x20-0x84	Reserved										
Reset Setting	0x85	SOFTRESET	R/W	0x00					SRST[7:0]				
-	0x86-0x89	Reserved											
Reset Setting	0x8A	SOFTRESET	R/W	0x00					SRST[15:8]				
-	0x8B-0xBF	Reserved											
Sensor setting	0xC0	SIN0_CFG	R/W	0x00	-	MASK_CONT_SW0	MASK_OFF_SW0	MASK_ON_SW0			GAIN_SIN0[3:0]		
	0xC1		R/W	0x00				ON_TH_SIN0[7:0]					
	0xC2		R/W	0x00					OFF_TH_SIN0[7:0]				
	0xC3	SIN1_CFG	R/W	0x00	-	MASK_CONT_SW1	MASK_OFF_SW1	MASK_ON_SW1			GAIN_SIN1[3:0]		
	0xC4		R/W	0x00				ON_TH_SIN1[7:0]					
	0xC5		R/W	0x00					OFF_TH_SIN1[7:0]				
	0xC6	SIN2_CFG	R/W	0x00	-	MASK_CONT_SW2	MASK_OFF_SW2	MASK_ON_SW2			GAIN_SIN2[3:0]		
	0xC7		R/W	0x00				ON_TH_SIN2[7:0]					
	0xC8		R/W	0x00					OFF_TH_SIN2[7:0]				
	0xC9	SIN3_CFG	R/W	0x00	-	MASK_CONT_SW3	MASK_OFF_SW3	MASK_ON_SW3			GAIN_SIN3[3:0]		
	0xCA		R/W	0x00				ON_TH_SIN3[7:0]					
	0xCB		R/W	0x00					OFF_TH_SIN3[7:0]				
	0xCC	SIN4_CFG	R/W	0x00	-	MASK_CONT_SW4	MASK_OFF_SW4	MASK_ON_SW4			GAIN_SIN4[3:0]		
	0xCD		R/W	0x00				ON_TH_SIN4[7:0]					
	0xCE		R/W	0x00					OFF_TH_SIN4[7:0]				
	0xCF	MONI_ACT	R/W	0x00	-	-	-	-	-	-	-	MONI_ACT	
	0xD0	CONTTIMES	R/W	0x00	CONTSSEL	-				CONT[5:0]			
	0xD1	OSTIMES	R/W	0x00			OST[3:0]			-	-	-	
	0xD2-0xDE	Reserved											
	Mask setting	0xDF	MASK_INTERRUPT	R/W	0x00	-	-	-	MSK_PERCAL	-	MSK_ERCAL	MSK_CAL	-
LED/PWM setting	0xE0	PWM0_CFG	R/W	0x00			FAL_PWM0[3:0]				RIS_PWM0[3:0]		
	0xE1		R/W	0x00			OFF_PWM0[3:0]				ON_PWM0[3:0]		
	0xE2		R/W	0x00	-	-	-	-	-	-	REP_PWM0[3:0]		
	0xE3	PWM1_CFG	R/W	0x00			FAL_PWM1[3:0]				RIS_PWM1[3:0]		
	0xE4		R/W	0x00			OFF_PWM1[3:0]				ON_PWM1[3:0]		
	0xE5		R/W	0x00	-	-	-	-	-	-	REP_PWM1[3:0]		
	0xE6	PWM2_CFG	R/W	0x00			FAL_PWM2[3:0]				RIS_PWM2[3:0]		
	0xE7		R/W	0x00			OFF_PWM2[3:0]				ON_PWM2[3:0]		
	0xE8		R/W	0x00	-	-	-	-	-	-	REP_PWM2[3:0]		
	0xE9	PWM3_CFG	R/W	0x00			FAL_PWM3[3:0]				RIS_PWM3[3:0]		
	0xEA		R/W	0x00			OFF_PWM3[3:0]				ON_PWM3[3:0]		
	0xEB		R/W	0x00	-	-	-	-	-	-	REP_PWM3[3:0]		
	0xEC	MASK_PWM_FINISH	R/W	0x00						MSK_PWM3	MSK_PWM2	MSK_PWM1	MSK_PWM0
	0xED	PWM_ASSIGN	R/W	0x00		PWMA_LED3[1:0]		PWMA_LED2[1:0]		PWMA_LED1[1:0]		PWMA_LED0[1:0]	
0xEE	R/W		0x00	-	-	-	-	-	-	-	PWMA_LED4[1:0]		
0xEF	LED_CALIB	R/W	0x00			PERIOD[3:0]			PWMCAL	PRECALCOND	PERCAL	LEDCAL	
Control	0xF0	CLR_INTERRUPT	R/W	0x00	-	-	-	PERCAL	-	ERCAL	CAL	INI	
	0xF1	CLR_DETECT_ON	R/W	0x00	-	-	-	ON_SW4	ON_SW3	ON_SW2	ON_SW1	ON_SW0	
	0xF2	CLR_DETECT_OFF	R/W	0x00	-	-	-	OFF_SW4	OFF_SW3	OFF_SW2	OFF_SW1	OFF_SW0	
	0xF3	CLR_DETECT_CONT	R/W	0x00	-	-	-	CONT_SW4	CONT_SW3	CONT_SW2	CONT_SW1	CONT_SW0	
	0xF4	CLR_DETECT_PWM_FINISH	R/W	0x00	-	-	-	-	PWM3	PWM2	PWM1	PWM0	
	0xF5-0xF8	Reserved											
	0xF9	PWM_SWITCH	R/W	0x00	-	-	-	-	-	-	-	CFG	
	0xFA	LED_CNT	R/W	0x00	-	-	-	LED4_EN	LED3_EN	LED2_EN	LED1_EN	LED0_EN	
	0xFB	PWM_SELECT	R/W	0x00	-	-	-	PWMS_LED4	PWMS_LED3	PWMS_LED2	PWMS_LED1	PWMS_LED0	
	0xFC	PWM_CNT	R/W	0x00	-	-	-	-	PWM3_EN	PWM2_EN	PWM1_EN	PWM0_EN	
	0xFD	Reserved											
0xFE	WACT	R/W	0x00					WACT[7:0]					
0xFF	CNT	R/W	0x00	FRCLRS	CALOVF	-	CALMOD	-	CFG	CAL	ACT		

**【0x00-0x04 : Sensor Data】**

Name: SIN\_DATA  
 Address: 0x00-0x04  
 Description: This registers shows 8bit ADC value of each sensor.

	Bit7	Bit6	Bit5	Bit4	Bit3	Bit2	Bit1	Bit0
0x00	SD_SIN0[7:0]							
0x01	SD_SIN1[7:0]							
0x02	SD_SIN2[7:0]							
0x03	SD_SIN3[7:0]							
0x04	SD_SIN4[7:0]							
R/W	R	R	R	R	R	R	R	R
Initial val.	0	0	0	0	0	0	0	0

**【0x0E : State of the peripheral PWM timer】**

Name: STATE\_PWM  
 Address: 0x0E  
 Description: 1 : The PWM timer is running. PWM state is on 'RISE', 'FALL', 'ON' or 'OFF'.  
 0 : The PWM timer is not running.

	Bit7	Bit6	Bit5	Bit4	Bit3	Bit2	Bit1	Bit0
0x0E	-	-	-	-	PWM3	PWM2	PWM1	PWM0
R/W	-	-	-	-	R	R	R	R
Initial val.	0	0	0	0	0	0	0	0

**【0x0F : State of the PWM sequence】**

Name: CONT\_PWM  
 Address: 0x0F  
 Description: 1 : PWM timer is running and not received stop command.  
 0 : PWM timer is running and received stop command. Or PWM timer is stopped.

	Bit7	Bit6	Bit5	Bit4	Bit3	Bit2	Bit1	Bit0
0x0F	-	-	-	-	PWM3	PWM2	PWM1	PWM0
R/W	-	-	-	-	R	R	R	R
Initial val.	0	0	0	0	0	0	0	0

**[0x10 : Interrupt factor]**

Name: INTERRUPT  
Address: 0x10

Description: This register shows the interrupt factors. Port INT outputs this register's OR operation.

**INI : Initialization finish :**

This register is set to '1' when initialization is complete after power-on-sequence or watch dog timer reset. This register is cleared by setting '0' to the bit INI that is included the 'Clear interrupt' registers (Address 0xF0).

**CAL : Software-calibration finish :**

This register is set to '1' when software calibration is complete. This register is cleared by setting '0' to the bit CAL that is included the 'Clear interrupt' registers (Address 0xF0).

**ERCAL : Self-re-calibration finish :**

This register is set to '1' when self-re-calibration is complete. Self-re-calibration runs automatically after the detection that IC should be re-calibration. This register is cleared by setting '0' to the bit ERCAL that is included the 'Clear interrupt' registers (Address 0xF0).

**PWM : PWM continuous flashing of LED finish :**

This register is set to '1' when LED's PWM drive has finished. This register is cleared by clearing every bit of the 'Interrupt of PWM continuous flashing' register.

**PERCAL : Periodic calibration finish :**

This register is set to '1' when periodic calibration is complete. This register is cleared by setting '0' to the bit PERCAL that is included the 'Clear interrupt' registers (Address 0xF0).

**ONDET : Detection of switch-on :**

This register is set to '1' when it detects a switch operation is considered to be On. This register is cleared by clearing every bit of the 'Detection Switch-On' register.

**OFFDET : Detection of switch-off :**

This register is set to '1' when it detects a switch operation is considered to be Off. This register is cleared by clearing every bit of the 'Detection Switch-Off' register.

**CONTDDET : Detection of continued touch :**

This register is set to '1' when it detects a continued touch switch operation. This register is cleared by clearing every bit of the 'Detection continuous touch' register.

	Bit7	Bit6	Bit5	Bit4	Bit3	Bit2	Bit1	Bit0
<b>0x10</b>	CONTDDET	OFFDET	ONDET	PERCAL	PWM	ERCAL	CAL	INI
<b>R/W</b>	R	R	R	R	R	R	R	R
<b>Initial val.</b>	0	0	0	0	0	0	0	0

**【0x11 : Detection Switch-On】**

Name: DETECT\_ON  
Address: 0x11

Description: This register indicates the change to ON from OFF of each switch.  
If the mask for the ON operation included in the sensor settings is enabled, this register is disabled.  
Logical OR of this register is ONDET included 'Interrupt factor' register.  
1 : Detect On. 0 :Not detect On.

	Bit7	Bit6	Bit5	Bit4	Bit3	Bit2	Bit1	Bit0
<b>0x11</b>	-	-	-	ON_SW4	ON_SW3	ON_SW2	ON_SW1	ON_SW0
<b>R/W</b>	-	-	-	R	R	R	R	R
<b>Initial val.</b>	0	0	0	0	0	0	0	0

**【0x12 : Detection Switch-Off】**

Name: DETECT\_OFF  
Address: 0x12

Description: This register indicates the change to OFF from ON of each switch.  
If the mask for the OFF operation included in the sensor settings is enabled, this register is disabled.  
Logical OR of this register is OFFDET included 'Interrupt factor' register.  
1 : Detect Off. 0 :Not detect Off.

	Bit7	Bit6	Bit5	Bit4	Bit3	Bit2	Bit1	Bit0
<b>0x12</b>	-	-	-	OFF_SW4	OFF_SW3	OFF_SW2	OFF_SW1	OFF_SW0
<b>R/W</b>	-	-	-	R	R	R	R	R
<b>Initial val.</b>	0	0	0	0	0	0	0	0

**【0x13 : Detection continuous touch】**

Name: DETECT\_CONT  
Address: 0x13

Description: This register indicates the detection of continuous touch of each switch.  
If the mask for the continuous touch operation included in the sensor settings is enabled, this register is disabled.  
Logical OR of this register is CONTDET included 'Interrupt factor' register.  
1 : Detect Continuous touch. 0 :Not detect Continuous touch.

	Bit7	Bit6	Bit5	Bit4	Bit3	Bit2	Bit1	Bit0
<b>0x13</b>	-	-	-	CONT_SW4	CONT_SW3	CONT_SW2	CONT_SW1	CONT_SW0
<b>R/W</b>	-	-	-	R	R	R	R	R
<b>Initial val.</b>	0	0	0	0	0	0	0	0

**【0x14 : Interrupt of PWM continuous flashing】**

Name: DETECT\_PWM\_FINISH  
Address: 0x14

Description: This register indicates the end of the each LED PWM drive. And in the case that the PWM function is stopped by the writing 0 to the PWM operation register (0xFC), this register is set to 1.  
Logical OR of this register is PWM included 'Interrupt factor' register.  
1 : Finished LED PWM drive. 0 :Clear.

	Bit7	Bit6	Bit5	Bit4	Bit3	Bit2	Bit1	Bit0
<b>0x14</b>	-	-	-	-	PWM3	PWM2	PWM1	PWM0
<b>R/W</b>	-	-	-	-	R	R	R	R
<b>Initial val.</b>	0	0	0	0	0	0	0	0



**[0x1B : State of interrupt from the peripherals]**

Name: STATE\_INT  
 Address: 0x1B  
 Description: This register shows the peripheral which issues an interrupt to MPU.  
 1 : Interrupt is. 0 : Interrupt is not.

	Bit7	Bit6	Bit5	Bit4	Bit3	Bit2	Bit1	Bit0
<b>0x1B</b>	PWM3	PWM2	PWM1	PWM0	WDT	-	AFE	I2C
<b>R/W</b>	R	R	R	R	R	-	R	R
<b>Initial val.</b>	0	0	0	0	0	0	0	0

**[0x1C : State of IC]**

Name: STATE  
 Address: 0x1C  
 Description: This register indicates the state of IC.  
 Indicates whether the IC is in calibration or not.  
 1 : In calibration. 0 : Not in calibration  
 The required time for calibration. : About 140 msec.

	Bit7	Bit6	Bit5	Bit4	Bit3	Bit2	Bit1	Bit0
<b>0x1C</b>	-	-	-	-	-	-	-	CALIB
<b>R/W</b>	-	-	-	-	-	-	-	R
<b>Initial val.</b>	0	0	0	0	0	0	0	0

**[0x1D : Sensor State]**

Name: STATE\_SIN  
 Address: 0x1D  
 Description: This register indicates the state of each sensor  
 1 : Switch-on. (Register 'SIN\_DATA' > Register 'TH\_ON')  
 0 : Switch-off. (Register 'SIN\_DATA' < Register 'TH\_OFF')

	Bit7	Bit6	Bit5	Bit4	Bit3	Bit2	Bit1	Bit0
<b>0x1D</b>	-	-	-	SIN4	SIN3	SIN2	SIN1	SIN0
<b>R/W</b>	-	-	-	R	R	R	R	R
<b>Initial val.</b>	0	0	0	0	0	0	0	0

**[0x1E : Read register for operation check of IC]**

Name: RACT  
 Address: 0x1E  
 Description: This register is a read register for operational check of the IC. The value written to the write register for operation check (Address is 0xFE) is copied to this register. If the write value and the read value are equal, MPU and I/F are operating normally.  
 The required time to copy to this register from the write register for operation check : About 20usec.

	Bit7	Bit6	Bit5	Bit4	Bit3	Bit2	Bit1	Bit0
<b>0x1E</b>	RACT[7:0]							
<b>R/W</b>	R	R	R	R	R	R	R	R
<b>Initial val.</b>	0	0	0	0	0	0	0	0

**[0x85 , 0x8A : Software Reset]**

Name: SOFTRESET  
 Address: 0x85, 0x8A  
 Description: These registers are used for hardware reset. If the 0x85 register's value is 0x55 and the 0x8A is 0xAA, then a hardware reset will be done.

	Bit7	Bit6	Bit5	Bit4	Bit3	Bit2	Bit1	Bit0
<b>0x85</b>	SRST[7:0]							
<b>0x8A</b>	SRST[15:8]							
<b>R/W</b>	R/W	R/W	R/W	R/W	R/W	R/W	R/W	R/W
<b>Initial val.</b>	0	0	0	0	0	0	0	0

**[0xC0-0xCE : Sensor Settings]**

Name: SIN\_CFG

Address: 0xC0 – 0xCE

Description: These registers are for setting of each SIN sensor.

The settings are the thresholds (from On to Off, and from Off to On), the gain and the mask function of the each switch operation (On / Off / Continuous touch).

**GAIN\_SIN\*[3:0] : Setting for the gain :**

This register is for setting the gain of AFE. The smaller the value of this register is, the higher the gain is.

Adjustment range :  $0x1 \leq \text{GAIN\_SIN} \leq 0xF$

The sensor which setting value is 0 has no switch function.

**ON\_TH\_SIN\*[7:0] : The threshold from Off to On :**

This register is the threshold from Off to On. This value is compared to the register SIN\_DATA. If the value of this register is larger than SIN\_DATA, the On operation is detected.

**OFF\_TH\_SIN\*[7:0] : The threshold from On to Off :**

This register is the threshold from On to Off. This value is compared to the register SIN\_DATA. If the value of this register is smaller than SIN\_DATA, the Off operation is detected.

Adjustment range :  $0x00 < \text{OFF\_SIN} < \text{ON\_SIN} < 0xFF$

The sensor which setting value is out of this range is unusable for switch operation.

**MSK\_ON\_SIN\*, MSK\_OFF\_SIN\*, MSK\_CONT\_SIN\* : Mask for the switch operation :**

This register is the mask function of the each switch operation (On / Off / Continuous touch).

If the mask function is enabled, the register for detection of switch operation is disabled.

1 : Mask function is enable. 0 : Mask function is disable (default).

	Bit7	Bit6	Bit5	Bit4	Bit3	Bit2	Bit1	Bit0
0xC0	-	MSK_CONT_SIN0	MSK_OFF_SIN0	MSK_ON_SIN0	GAIN_SIN0[3:0]			
0xC1	ON_TH_SIN0[7:0]							
0xC2	OFF_TH_SIN0[7:0]							
0xC3	-	MSK_CONT_SIN1	MSK_OFF_SIN1	MSK_ON_SIN1	GAIN_SIN1[3:0]			
0xC4	ON_TH_SIN1[7:0]							
0xC5	OFF_TH_SIN1[7:0]							
0xC6	-	MSK_CONT_SIN2	MSK_OFF_SIN2	MSK_ON_SIN2	GAIN_SIN2[3:0]			
0xC7	ON_TH_SIN2[7:0]							
0xC8	OFF_TH_SIN2[7:0]							
0xC9	-	MSK_CONT_SIN3	MSK_OFF_SIN3	MSK_ON_SIN3	GAIN_SIN3[3:0]			
0xCA	ON_TH_SIN3[7:0]							
0xCB	OFF_TH_SIN3[7:0]							
0xCC	-	MSK_CONT_SIN4	MSK_OFF_SIN4	MSK_ON_SIN4	GAIN_SIN4[3:0]			
0xCD	ON_TH_SIN4[7:0]							
0xCE	OFF_TH_SIN4[7:0]							
R/W	R/W	R/W	R/W	R/W	R/W	R/W	R/W	R/W
Initial val.	0	0	0	0	0	0	0	0

**[0xCF : Monitor activity of the sensor]**

Name: MONI\_ACT

Address: 0xCF

Description: This register is used to select whether to monitor the register ACT (scan enable bit at the address 0xFF).

The monitor's purpose is to prevent erroneous stop of detection of the AFE.

If the state that the AFE scan is stopped in the case that the monitor function is enabled is detected, the AFE scan will be self-restarted.

Monitor function is executed about 300 msec.

1 : Monitor function is enabled. 0 : Monitor function is disabled (default).

	Bit7	Bit6	Bit5	Bit4	Bit3	Bit2	Bit1	Bit0
0xCF	-	-	-	-	-	-	-	MONI_ACT
R/W	-	-	-	-	-	-	-	R/W
Initial val.	0	0	0	0	0	0	0	0

**【0xD0 : Configuration continuous touch】**

Name: CONTTIMES  
 Address: 0xD0  
 Description: CONTSEL : This register is to select the interrupt frequency by detection continuous touch.  
                   1 : Every continuous touch period.  
                   0 : First detect only.  
 CONT[5:0] : Continuous touch period is about 0.1[sec] x CONT.  
 If the setting value is 0x0, continuous touch function is disable.  
 (0.1sec ≤ Continuous touch period ≤ 6.3sec)

	Bit7	Bit6	Bit5	Bit4	Bit3	Bit2	Bit1	Bit0
<b>0xD0</b>	CONTSEL	-	CONT[5:0]					
<b>R/W</b>	R/W	-	R/W	R/W	R/W	R/W	R/W	R/W
<b>Initial val.</b>	0	0	0	0	0	0	0	0

**【0xD1 : Configuration oversampling】**

Name: OSTIMES  
 Address: 0xD1  
 Description: OST[3:0]: This register is the number of times of oversampling for canceling chattering to the 'ON' or 'OFF' operation. If the continuance of the 'ON' or 'OFF' operations is lower than this register, the operations are ignored. If this register value is '0', the number of times of oversampling is '1'.  
 Sampling rate : About 14.8msec.

	Bit7	Bit6	Bit5	Bit4	Bit3	Bit2	Bit1	Bit0
<b>0xD1</b>	OST[3:0]				-	-	-	-
<b>R/W</b>	R/W	R/W	R/W	R/W	-	-	-	-
<b>Initial val.</b>	0	0	0	0	0	0	0	0

**【0xDF : Mask interrupt】**

Name: MASK\_INTERRUPT  
 Address: 0xDF  
 Description: This register is for mask to the interrupt factor. The masked interrupt factor is not shown on the register 'Interrupt factor (address 0x10)', so it does not affect to output port INT.  
                   1 : Masked   0 : Unmasked (default)

**MSK\_CAL : Mask for Software-calibration finish :**

This bit does mask to the interrupt of Software-calibration finish (the bit CAL in the register 'Interrupt factor' (address 0x10)).

**MSK\_ERCAL : Mask for Self-calibration finish :**

This bit does mask to the interrupt of Self-calibration finish (the bit ERCAL in the register 'Interrupt factor' (address 0x10)).

**MSK\_PERCAL : Mask for Periodic calibration finish :**

This bit does mask to the interrupt of Periodic calibration finish (the bit PERCAL in the register 'Interrupt factor' (address 0x10)).

	Bit7	Bit6	Bit5	Bit4	Bit3	Bit2	Bit1	Bit0
<b>0xDF</b>	-	-	-	MSK_PERCAL	-	MSK_ERCAL	MSK_CAL	-
<b>R/W</b>	-	-	-	R/W	-	R/W	R/W	-
<b>Initial val.</b>	0	0	0	0	0	0	0	0

**[0xE0-0xEB : Configuration of PWM]**

Name: PWM\_CFG  
 Address: 0xE0 – 0xEB  
 Description: Each of the 4 PWM timers (PWM-0/1/2/3) has 5 parameters.  
 When the register for PWM operation (0xFC) is changed from 0 to 1, these setting will be enabled.

- I. RIS\_PWM\* : Rising Time      Adjustment range : 0x0 ≤ RIS\_PWM ≤ 0xF  
 Rising Time = About 317msec x RIS\_PWM\* (0 ≤ Rising Time ≤ 4755 [msec])
- II. FAL\_PWM\* : Falling Time      Adjustment range : 0x0 ≤ FAL\_PWM ≤ 0xF  
 Falling Time = About 317msec x FAL\_PWM\* (0 ≤ Falling Time ≤ 4755 [msec])
- III. ON\_PWM\* : Lights-On Time.      Adjustment range : 0x1 ≤ RIS\_PWM ≤ 0xF.  
 Lights-On Time = About 300msec x ON\_PWM\* (300 ≤ Lights-On Time ≤ 4500 [msec])  
 If the setting value is 0x0, the PWM timer continues to lighting. In the case of continuous lighting, the way how to turn off the light is to change the value of the register for PWM operation (0xFC) from 1 to 0.
- IV. OFF\_PWM\* : Lights-Off Time.      Adjustment range : 0x0 ≤ OFF\_PWM ≤ 0xF  
 Lights-Off Time = About 300msec x OFF\_PWM\* (0 ≤ Lights-Off Time ≤ 4500 [msec])
- V. REP\_PWM\* : Repeat Count.  
 In the case that the setting value is 0x0 or 0x1, non repeat.  
 In the case that the setting value is 0xF, unlimited repeat.  
 In the case that the setting value is from 0x2 to 0xE, repeat as many times as the setting value.

When the PWM function is finished, the bit PWM which is included in 'Interrupt factor' register (0x10) will be set to 1 and the level of the port INT will be High-Level. The bit PWM which is included in 'Interrupt factor' register is cleared by the writing 0 to the bit PWM which is included in 'Interrupt clear' register. And FAL\_PWM is applied in the falling time.

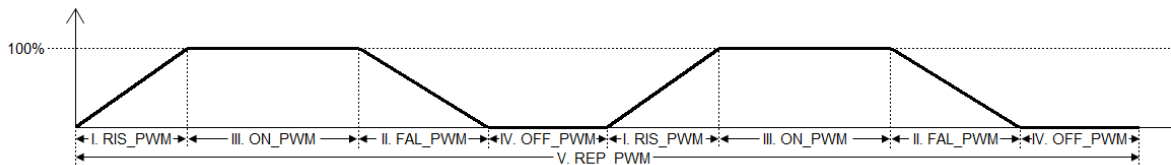

Figure 7. PWM waveform

	Bit7	Bit6	Bit5	Bit4	Bit3	Bit2	Bit1	Bit0
0xE0	FAL_PWM0[3:0]			RIS_PWM0[3:0]				
0xE1	OFF_PWM0[3:0]			ON_PWM0[3:0]				
0xE2	-	-	-	-	REP_PWM0[3:0]			
0xE3	FAL_PWM1[3:0]			RIS_PWM1[3:0]				
0xE4	OFF_PWM1[3:0]			ON_PWM1[3:0]				
0xE5				REP_PWM1[3:0]				
0xE6	FAL_PWM2[3:0]			RIS_PWM2[3:0]				
0xE7	OFF_PWM2[3:0]			ON_PWM2[3:0]				
0xE8				REP_PWM2[3:0]				
0xE9	FAL_PWM3[3:0]			RIS_PWM3[3:0]				
0xEA	OFF_PWM3[3:0]			ON_PWM3[3:0]				
0xEB				REP_PWM3[3:0]				
R/W	R/W	R/W	R/W	R/W	R/W	R/W	R/W	R/W
Initial val.	0	0	0	0	0	0	0	0

**[ 0xEC : Mask Interrupt of PWM continuous flashing]**

Name: MASK\_PWM\_FINISH  
 Address: 0xEC  
 Description: This register is the mask function for the interrupt of the end of the each LED PWM drive.  
 1 : Masked    0 : Unmasked (default)

	Bit7	Bit6	Bit5	Bit4	Bit3	Bit2	Bit1	Bit0
0xEC	-	-	-	-	MSK_PWM3	MSK_PWM2	MSK_PWM1	MSK_PWM0
R/W	-	-	-	-	R/W	R/W	R/W	R/W
Initial val.	0	0	0	0	0	0	0	0

**[0xED-0xEE : LED-PWM assign]**

Name: PWM\_ASSIGN  
 Address: 0xED – 0xEE  
 Description: These registers are used to set any PWM setting from the four settings to each LED port.  
 0x0 : Assign PWM-0  
 0x1 : Assign PWM-1  
 0x2 : Assign PWM-2  
 0x3 : Assign PWM-3  
 These registers value is set by writing '1' to the Switch PWM assign register (Address = 0xF9).

	Bit7	Bit6	Bit5	Bit4	Bit3	Bit2	Bit1	Bit0
0xED	PWMA_LED3[1:0]		PWMA_LED2[1:0]		PWMA_LED1[1:0]		PWMA_LED0[1:0]	
0xEE	-	-	-	-	-	-	PWMA_LED4[1:0]	
R/W	R/W	R/W	R/W	R/W	R/W	R/W	R/W	R/W
Initial val.	0	0	0	0	0	0	0	0

**[0xEF : LED calibration]**

Name: LED\_CALIB  
 Address: 0xEF  
 Description: This register is used to select whether to perform the calibration. The calibration is done by writing to any LED port or by periodic calibration.

**LEDCAL : Self-calibration enable bit at controlled for LED/PWM :**

This register is used to select whether to perform the self-calibration when the corresponding registers for LED/PWM control are written. The corresponding registers' addresses are from 0xF9 to 0xFC.  
 1 : Not perform the self-calibration. 0 : Perform the self-calibration (default).

**PERCAL : Periodical calibration :**

This register is used to select whether to perform the periodical calibration.  
 1 : Not perform the periodical calibration. 0 : Perform the periodical calibration (default).

**PERCALCOND : Condition of the periodical calibration :**

This register is used to select the condition to perform the periodical calibration.  
 1 : Always. 0 : At any LED port is lighting (default).

**PWMCAL : Condition of the periodical calibration when the PWM function is active :**

This register is used to select whether to perform the periodical calibration in the case that the periodical calibration is enable.  
 1 : Perform the periodical calibration regardless of the condition of the LED port assigned to PWM function.  
 0 : Perform the periodical calibration only the LED port assigned to PWM function is set to inactive (default).

Conditions	bit state		Periodical Calibration
	State of the LED port assigned to PWM function		
	PERCAL	PWMCAL	
With flashing by PWM drive.	0	0	Not performed
		1	Performed
	1	0	Not performed
		1	Performed
Without flashing by PWM drive.	0	0	Performed
		1	Performed
	1	0	Not performed
		1	Not performed

**PERIOD[7:4] : Interval of the periodical calibration :**

This register is used to set the interval of the periodical calibration.  
 The interval of the periodical calibration = About 5 seconds x (PERIOD + 1)  
 (5 seconds ≤ Interval time ≤ 80 seconds)

	Bit7	Bit6	Bit5	Bit4	Bit3	Bit2	Bit1	Bit0
0xEF	PERIOD[3:0]				PWMCAL	PERCALCOND	PERCAL	LEDCAL
R/W	R/W	R/W	R/W	R/W	R/W	R/W	R/W	R/W
Initial val.	0	0	0	0	0	0	0	0

**【0xF0 : Clear Interrupt】**

Name: CLR\_INTERRUPT  
 Address: 0xF0  
 Description: Clear Interrupt Register.

**INI : Clear Interrupt of Initialization finish :**

Clear the INI interrupt by writing '0' to this register. If the written value is '1', the operation is not valid.

**CAL : Clear Interrupt of Software-calibration finish :**

Clear the CAL interrupt by writing '0' to this register. If the written value is '1', the operation is not valid.

**ERCAL : Clear Interrupt of Self-calibration finish :**

Clear the ERCAL interrupt by writing '0' to this register. If the written value is '1', the operation is not valid.

**PERCAL : Clear Interrupt of Periodic calibration finish :**

Clear the PERCAL interrupt by writing '0' to this register. If the written value is '1', the operation is not valid.

	Bit7	Bit6	Bit5	Bit4	Bit3	Bit2	Bit1	Bit0
<b>0xF0</b>	-	-	-	PERCAL	-	ERCAL	CAL	INI
<b>R/W</b>	-	-	-	R/W	-	R/W	R/W	R/W
<b>Initial val.</b>	-	-	-	0	-	0	0	0

**【0xF1 : Clear Switch-On】**

Name: CLR\_DETECT\_ON  
 Address: 0xF1  
 Description: DETECT\_ON Clear Register. Clear the DETECT\_ON by writing '0' in these registers. If the written value is '1', the operation is not valid.

1 : Invalid. 0 : Clear.

	Bit7	Bit6	Bit5	Bit4	Bit3	Bit2	Bit1	Bit0
<b>0xF1</b>	-	-	-	ON_SW4	ON_SW3	ON_SW2	ON_SW1	ON_SW0
<b>R/W</b>	-	-	-	R/W	R/W	R/W	R/W	R/W
<b>Initial val.</b>	0	0	0	0	0	0	0	0

**【0xF2 : Clear Switch-Off】**

Name: CLR\_DETECT\_OFF  
 Address: 0xF2  
 Description: DETECT\_OFF Clear Register. Clear the DETECT\_OFF by writing '0' in these registers. If the written value is '1', the operation is not valid.

1 : Invalid. 0 : Clear.

	Bit7	Bit6	Bit5	Bit4	Bit3	Bit2	Bit1	Bit0
<b>0xF2</b>	-	-	-	OFF_SW4	OFF_SW3	OFF_SW2	OFF_SW1	OFF_SW0
<b>R/W</b>	-	-	-	R/W	R/W	R/W	R/W	R/W
<b>Initial val.</b>	0	0	0	0	0	0	0	0

**【0xF3: Clear continuous touch】**

Name: CLR\_DETECT\_CONT  
 Address: 0xF3  
 Description: DETECT\_CONT Clear Register. Clear the DETECT\_CONT by writing '0' to these registers. If the written value is '1', the operation is not valid.

1 : Invalid. 0 : Clear.

	Bit7	Bit6	Bit5	Bit4	Bit3	Bit2	Bit1	Bit0
<b>0xF3</b>	-	-	-	CONT_SW4	CONT_SW3	CONT_SW2	CONT_SW1	CONT_SW0
<b>R/W</b>	R/W	R/W	R/W	R/W	R/W	R/W	R/W	R/W
<b>Initial val.</b>	0	0	0	0	0	0	0	0

**【0xF4 : Clear Interrupt of PWM continuous flashing】**

Name: CLR\_DETECT\_PWM\_FINISH  
 Address: 0xF4  
 Description: DETECT\_PWM\_FINISH Clear Register. Clear the DETECT\_PWM\_FINISH by writing '0' to these registers.  
 If the written value is '1', the operation is not valid.  
 1 : Invalid. 0 : Clear.

	Bit7	Bit6	Bit5	Bit4	Bit3	Bit2	Bit1	Bit0
<b>0xF4</b>	-	-	-	-	PWM3	PWM2	PWM1	PWM0
<b>R/W</b>	-	-	-	-	R/W	R/W	R/W	R/W
<b>Initial val.</b>	0	0	0	0	0	0	0	0

**【0xF9 : Switch PWM assign】**

Name: PWM\_SWITCH  
 Address: 0xF9  
 Description: **CFG : Switch PWM assign :**  
 If the written value is '1', the PWM configurations (Address from 0xED to 0xEE) are valid.

	Bit7	Bit6	Bit5	Bit4	Bit3	Bit2	Bit1	Bit0
<b>0xF9</b>	-	-	-	-	-	-	-	CFG
<b>R/W</b>	-	-	-	-	-	-	-	R/W
<b>Initial val.</b>	0	0	0	0	0	0	0	0

**【0xFA : Control LED port】**

Name: LED\_CNT  
 Address: 0xFA  
 Description: This register is used to control each LED port.  
 1 : Always On (High drive) 0 : Always Off (Low drive)

	Bit7	Bit6	Bit5	Bit4	Bit3	Bit2	Bit1	Bit0
<b>0xFA</b>	-	-	-	LED4_EN	LED3_EN	LED2_EN	LED1_EN	LED0_EN
<b>R/W</b>	-	-	-	R/W	R/W	R/W	R/W	R/W
<b>Initial val.</b>	0	0	0	0	0	0	0	0

**【0xFB : Select PWM】**

Name: PWM\_SELECT  
 Address: 0xFB  
 Description: This register is used to select whether PWM function for each LED port.  
 1 : Use PWM function. 0 : Not use PWM function (default).

	Bit7	Bit6	Bit5	Bit4	Bit3	Bit2	Bit1	Bit0
<b>0xFB</b>	-	-	-	PWMS_LED4	PWMS_LED3	PWMS_LED2	PWMS_LED1	PWMS_LED0
<b>R/W</b>	-	-	-	R/W	R/W	R/W	R/W	R/W
<b>Initial val.</b>	0	0	0	0	0	0	0	0

**【0xFC : Control PWM function】**

Name: PWM\_CNT  
 Address: 0xFC  
 Description: This register is used to control PWM function.  
 By writing '1' to the register which value is '0', the PWM function is started.  
 By writing '0' to the register which value is '1', the PWM function is stopped.  
 In the case that the PWM function is finished by reaching repeat number, set '0' to this register for the next operation of PWM function.

	Bit7	Bit6	Bit5	Bit4	Bit3	Bit2	Bit1	Bit0
<b>0xFC</b>	-	-	-	-	PWM3_EN	PWM2_EN	PWM1_EN	PWM0_EN
<b>R/W</b>	-	-	-	-	R/W	R/W	R/W	R/W
<b>Initial val.</b>	0	0	0	0	0	0	0	0

**[0xFE : Write register for operation check of IC]**

Name: WACT  
Address: 0xFE

Description: This register is a write register for operational check of the IC. This register's value is copied to the read register for operation check (Address is 0x1E). If the write value and the read value are equal, MPU and I/F are operating normally.

	Bit7	Bit6	Bit5	Bit4	Bit3	Bit2	Bit1	Bit0
<b>0xFE</b>	WACT[7:0]							
<b>R/W</b>	R/W	R/W	R/W	R/W	R/W	R/W	R/W	R/W
<b>Initial val.</b>	0	0	0	0	0	0	0	0

**[0xFF : AFE Control]**

Name: CNT  
Address: 0xFF

Description: This register is for controlling AFE.

**ACT : Scan Enable :**

This bit is the scan enable for AFE.  
1 : Scan Enable. 0 : Scan Disable.

**CAL : Act Soft-calibration :**

The calibration is operated by setting '1'.

**CFG : Enable Configuration Value :**

Writing '1' to this bit, the value of Sensor configuration (address from 0xC0 to 0xD1), Mask Configuration (address 0xDF), Mask Interrupt of PWM continuous flashing (address = 0xEC), LED calibration (address = 0xEF), FRCRLS and CALOVF are effective to the IC's operation.

**CALMOD : Select Software-calibration mode :**

0: All sensors are the targets for soft-calibration. If some sensor has the value more than the threshold for 'OFF' to 'ON', the sensors are changed to 'OFF', and DETECT\_OFF register is enabled (default).  
1: The sensors with the value more than the threshold for 'OFF' to 'ON' are not calibrated.

**CALOVF : Select Self-calibration mode detected overflow :**

When the periodic calibration is active, it selects whether to activate self-calibration or not to activate in the case that the sensor values are over the dynamic range of included ADC.  
0: Deactivate self-calibration (default). 1: Activate self-calibration

**FRCRLS : Select Force OFF at continuous touch :**

When the continuous touch is active, select whether to activate force OFF or not in the case that the max value after detect continuous touch minus the current sensor value is more than the threshold for 'OFF' to 'ON'.  
0 : Deactivate force OFF (default). 1: Activate force OFF.  
By force OFF is performed, the continuous touch sensor is changed to OFF, and DETECT\_OFF register is enabled.

	Bit7	Bit6	Bit5	Bit4	Bit3	Bit2	Bit1	Bit0
<b>0xFF</b>	FRCRLS	CALOVF	-	CALMOD	-	CFG	CAL	ACT
<b>R/W</b>	R/W	R/W	-	R/W	-	R/W	R/W	R/W
<b>Initial val.</b>	0	0	-	0	-	0	0	0



Timing Charts

Host interface

2-wire serial bus.  
 Compatible with I<sup>2</sup>C protocol.  
 Support slave mode only.  
 7-bit Slave Address = 0x4C (in the case of ADR = 'L'), 0x4D (in the case of ADR = 'H').  
 Standard-mode (data transfer rate of 100kbit/s), Fast-mode (data transfer rate of 400kbit/s).  
 Supports sequential read.

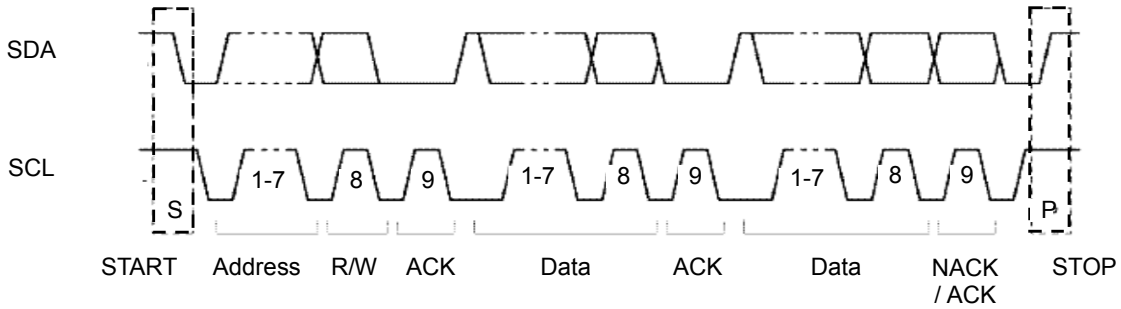

Figure 8. 2-wire serial bus data format

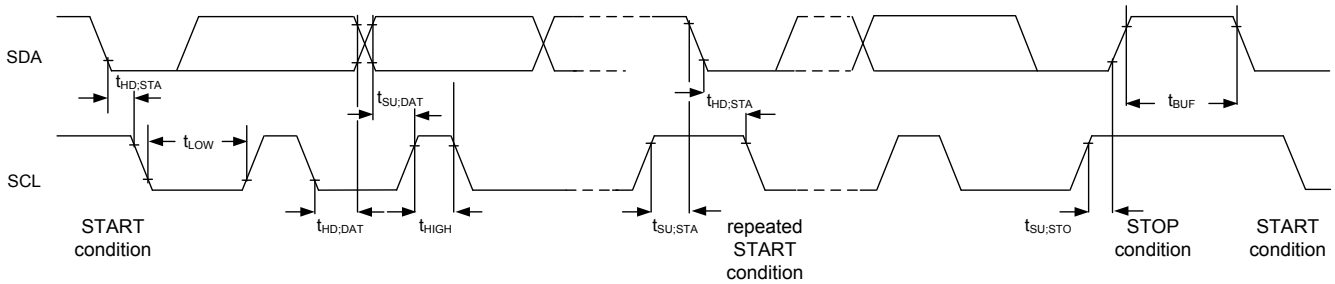
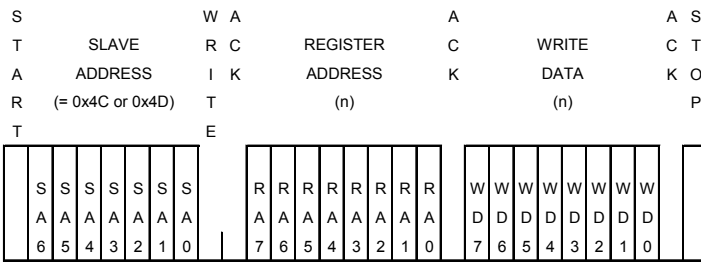

Figure 9. 2-wire serial bus data timing chart

Parameter	Symbol	Standard-mode		Fast-mode		Unit
		MIN	MAX	MIN	MAX	
SCL clock frequency	f <sub>SCL</sub>	0	100	0	400	kHz
Hold time (repeated) START condition	t <sub>HD,STA</sub>	4.0	-	0.6	-	usec
LOW period of the SCL clock	t <sub>LOW</sub>	4.7	-	1.3	-	usec
HIGH period of the SCL clock	t <sub>HIGH</sub>	4.0	-	0.6	-	usec
Data hold time	t <sub>HD,DAT</sub>	0.1	3.45	0.1	0.9	usec
Data set-up time	t <sub>SU,DAT</sub>	0.25	-	0.1	-	usec
Set-up time for a repeated START condition	t <sub>SU,STA</sub>	4.7	-	0.6	-	usec
Set-up time for STOP condition	t <sub>SU,STO</sub>	4.0	-	0.6	-	usec
Bus free time between STOP and START condition	t <sub>BUF</sub>	4.7	-	1.3	-	usec

\* It is necessary that interval time for writing to register which address is from 0xF0 to 0xFF is more than 650usec.

Byte Write



SA : Slave Address  
 RA : Register Address  
 RD : Read Data  
 WD : Write Data

Random Read

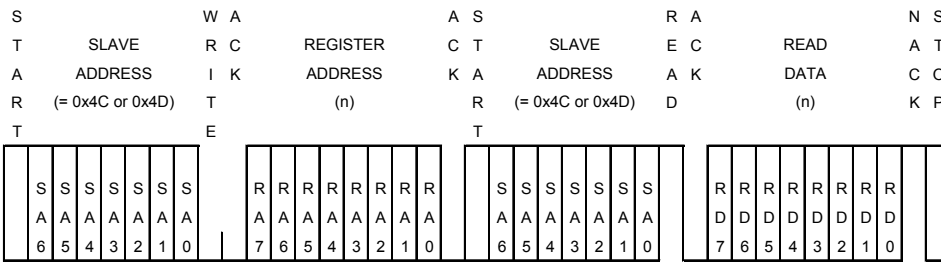

Sequential Read

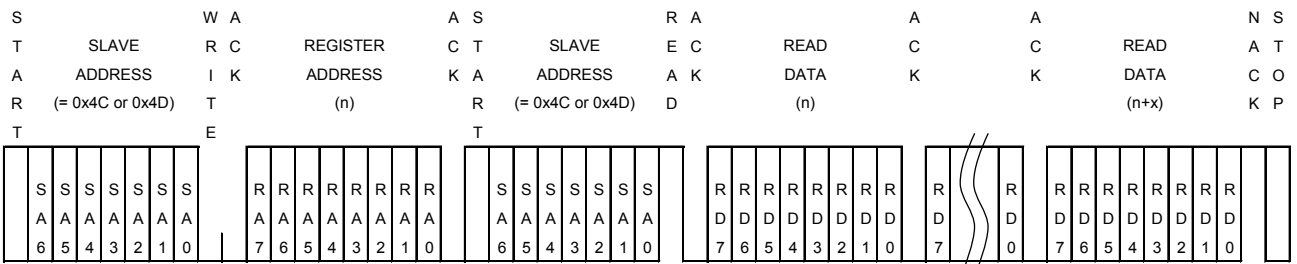

Figure 10. 2-wire serial bus protocol

Scan Rate

After scan each sensor in time series, MPU convert to the switch operations from the detected results. One scan rate is about 14.8msec at typical.

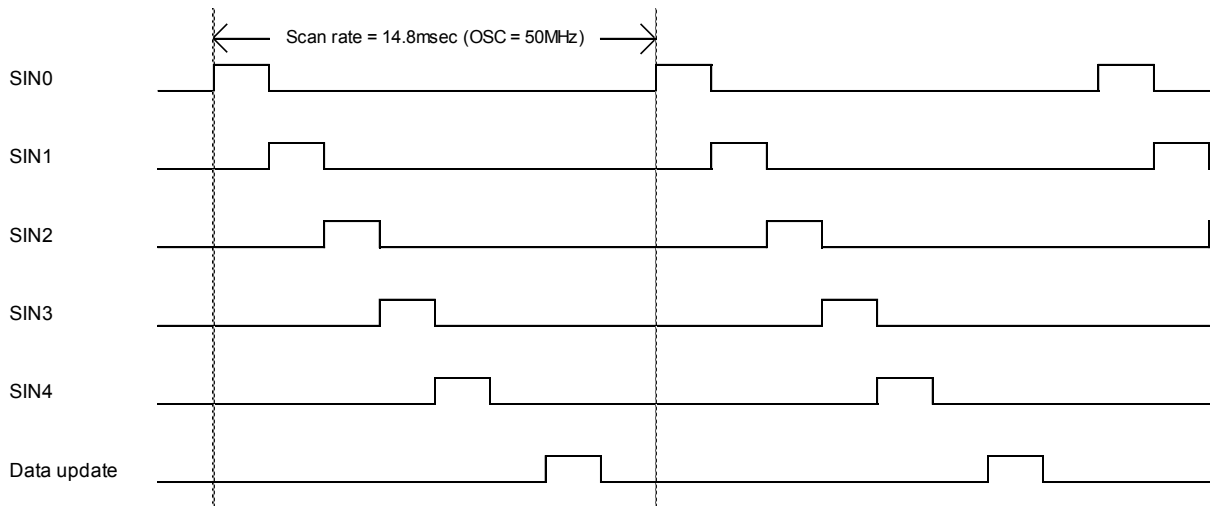

Figure 11. Timing chart of scan rate

Power on sequence

Power supply pin is VDD only. AVDD and DVDD are supplied by each LDO included this IC, so that have no priority about power on sequence. When VDD reaches to the effective voltage, power-on-reset which initializes the digital block is released.  
 Power-on-reset is monitoring VDD, so it needs that decoupling capacitor's value is suitable for VDD rising time. (DVDD's rising time < VDD's rising time.)

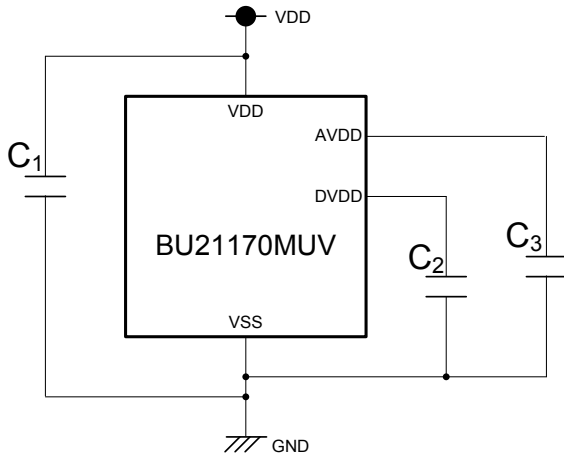

Figure 12. Arrangement of external decoupling capacitors

Recommended value of external capacitors

C1	0.1uF	VDD decoupling capacitor
C2	1.0uF	DVDD decoupling capacitor
C3	2.2uF	AVDD decoupling capacitor

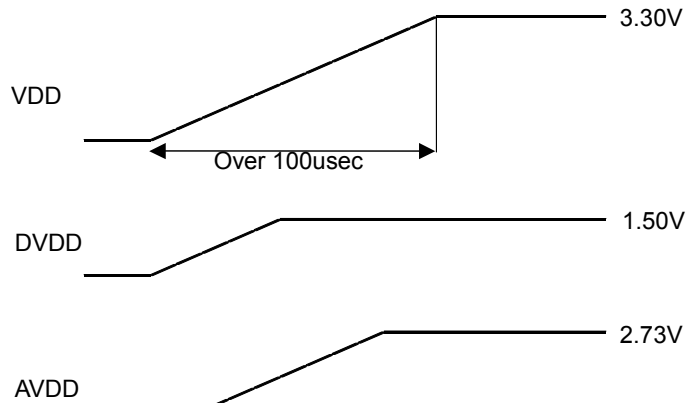

Figure 13. Timing chart of power on sequence

When power-on-reset is released, MPU starts initial sequence. Inform by the INT port to the host that the initialization has been completed. After verify that the initialization has been completed, the host will need to resend the command to this IC.  
 In the case that WDTR is released as well, MPU starts initial sequence. If WDTR has released, all registers of this IC have been initialized. So the host will need to resend the command to this IC.

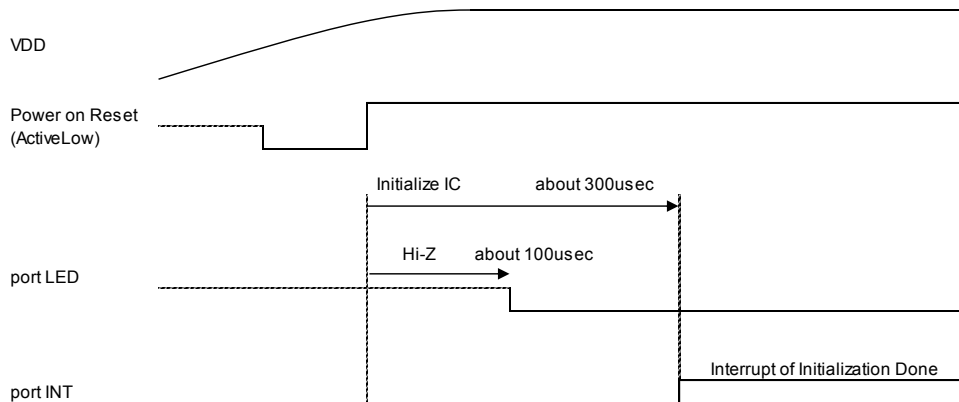

Figure 14. Timing chart of initialization

Initialize operation

This IC is initialized and all registers are cleared by Power-on reset, WDT time-out reset, and Software reset command. When initialization is complete, the register INI is set to '1' and I/O port INT is set to 'H'. After the IC is initialized, write the configuration values to registers. After setting configuration values, the next action is sensor calibration. Set '1' to the registers ACT, CFG and CAL on Address 0xFF, so calibration sequence is performed.

IC's initialization after hardware reset

- Power-on-reset
- WDTR (Watchdog timer timeout reset)
- Software reset command

The above actions act hardware reset to the IC. Hardware reset clear the all registers to the default value and initialize MPU. After hardware reset, MPU runs the initial sequence of firmware on Program ROM.

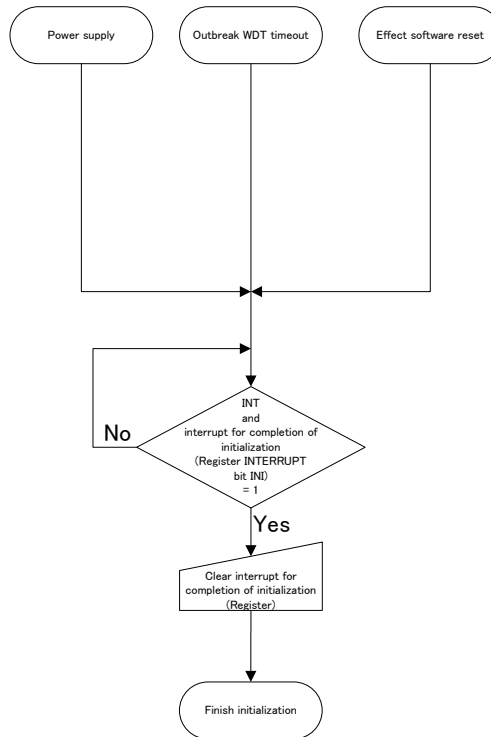

Figure 15. Initialization routine after hardware reset

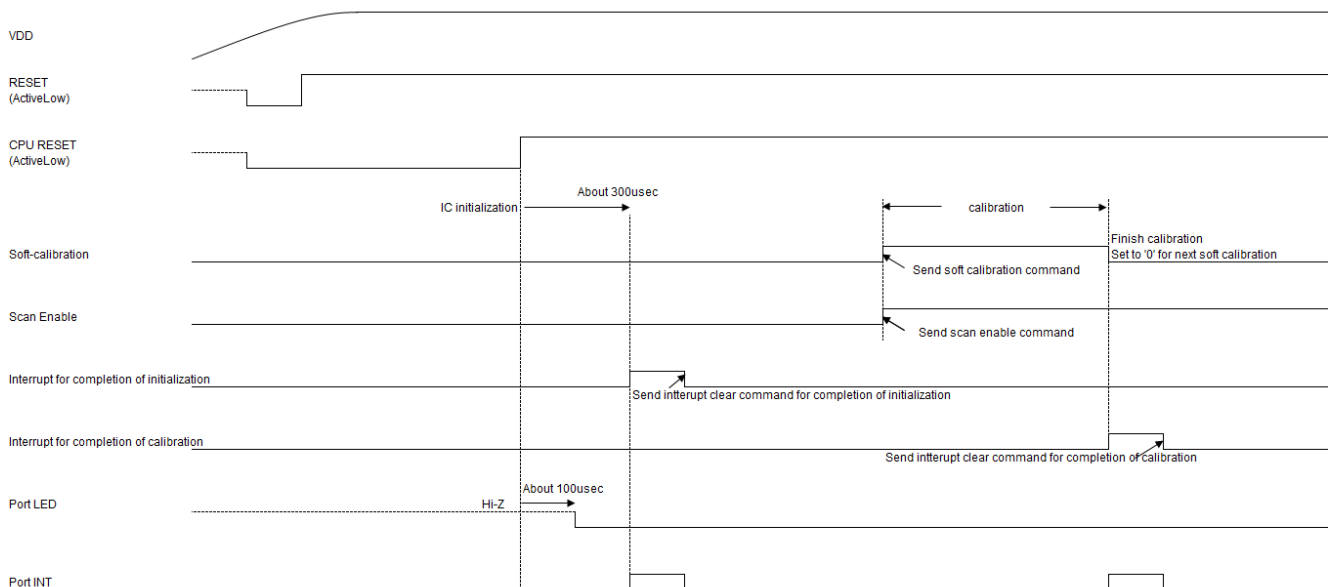

Figure 16. Configuration sequence including clear interrupts

## Calibration

### Self-calibration

Self-calibration is performed by this IC automatically. It is performed in the following cases.

1. Detect drift condition :  
When the IC detects the drift condition, the IC acts self-calibration. When calibration is complete, the interrupt factor register CAL is set to '1' and I/O port INT is set to 'H'. When there is the sensor with the sensor value more than the threshold for 'Off to On', IC does not detect drift condition. The interrupt factor register CAL is maskable by the mask interrupt register CAL. The interrupt factor register CAL is cleared by writing '1' to the interrupt clear register CAL.
2. Detect noise :  
When the IC detects the noise, the IC changes the scan rate to not synchronize with the noise, and the IC acts self-calibration. When calibration is complete, the Interrupt factor register CAL is set to '1' and I/O port INT is set to 'H'. The interrupt factor register CAL is maskable by the mask interrupt register CAL. The interrupt factor register CAL is cleared by writing '1' to the interrupt clear register CAL.
3. Detect incorrect operation :  
When the finger is on the sensor at the calibration, the sensor base state is with the finger. Without the finger, the sensor value is under the base state value. This abnormal condition is defined to incorrect operation. Detected incorrect operation, the IC acts self-calibration. The interrupt factor register CAL is maskable by the mask interrupt register CAL. The interrupt factor register CAL is cleared by writing '1' to the interrupt clear register CAL.

### Software-calibration

Software-calibration is performed by the command from the host.

1. Write '1' to the Act Software-calibration bit.
2. Finishing the calibration, the Software-calibration finish bit (CAL on Address0x10) is set to '1' and I/O port INT is set to 'H'. For next calibration, clear the interrupt.

When the sensor setting value is changed, it is necessary to execute a soft calibration. It is necessary for changing the value of the sensor setting that the scan is disabled.

In the act of calibration, sensor values are not changed. So the switching operations are invalid.

If the software-calibration is released at sensing sensors, IC acts calibration at next sensing sensors.

### LED calibration

When the register for LED/PWM drivers operation (address area from 0xF9 to 0xFC) is written, this IC is selectable whether to perform self-calibration. Selecting whether to perform the LED calibration is defined by the configuration for calibration register (LEDCAL on Address 0xEF).

If there is the writing to the register for LED/PWM drivers operation (address area from 0xF9 to 0xFC), when the finger on the sensors. Incorrect operation will be detected at the finger leaving, and so IC will act self-calibration.

### Periodical calibration

The periodical calibration is to perform self-calibration periodically. This IC is selectable whether to perform periodical calibration. Selecting whether to perform the periodical calibration is defined by the configuration for calibration register (PERCAL on Address0xEF).

The sensor with the finger is not calibrated by the periodical calibration.

Whenever periodical calibration is complete, the interrupt factor register PERCAL is set to '1' and I/O port INT is set to 'H'. The interrupt factor register PERCAL is maskable by the mask interrupt register PERCAL. The interrupt factor register CAL is cleared by writing '1' to the interrupt clear register PERCAL.

### Interrupt when multi calibration factor occurs

The calibration of the four factors to carry out the calibration is different respectively. Therefore, state the calibration of another is started during the conduct of certain calibration, the conflict occurs.

If the calibration different conditions occur in the middle of the calibration, calibration being performed to stop, a new calibration is carried out from the beginning.

The interrupt by finishing the first factor's calibration is set, and the interrupt by the new factor's calibration is set too.

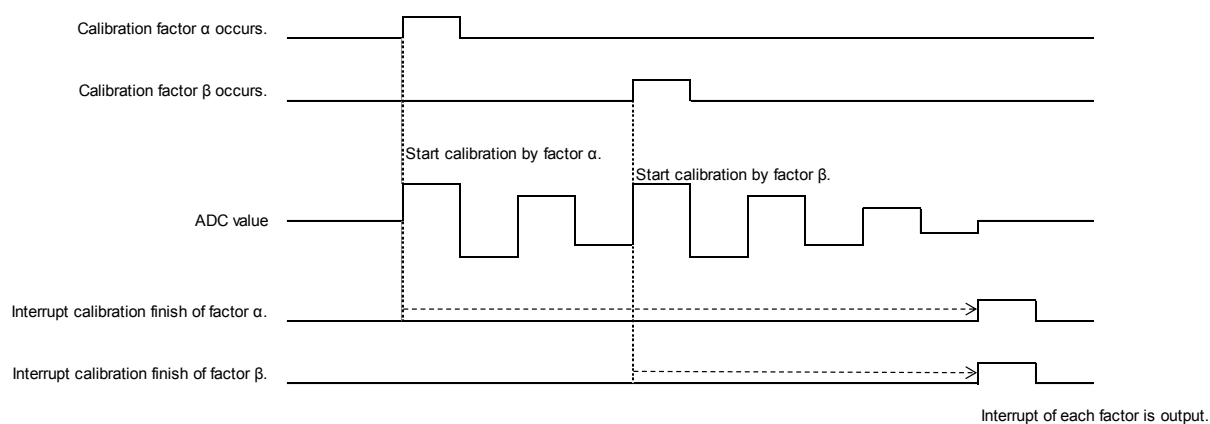

Figure 17. Interrupt when multi calibration factor occurs

### Switch operation

Every sensor is used for simple switch. Each switch has the registers of detected Touch/Release/Hold operations. Every switch supports to multi-detect Touch/Release/Hold. Unused switches are maskable.

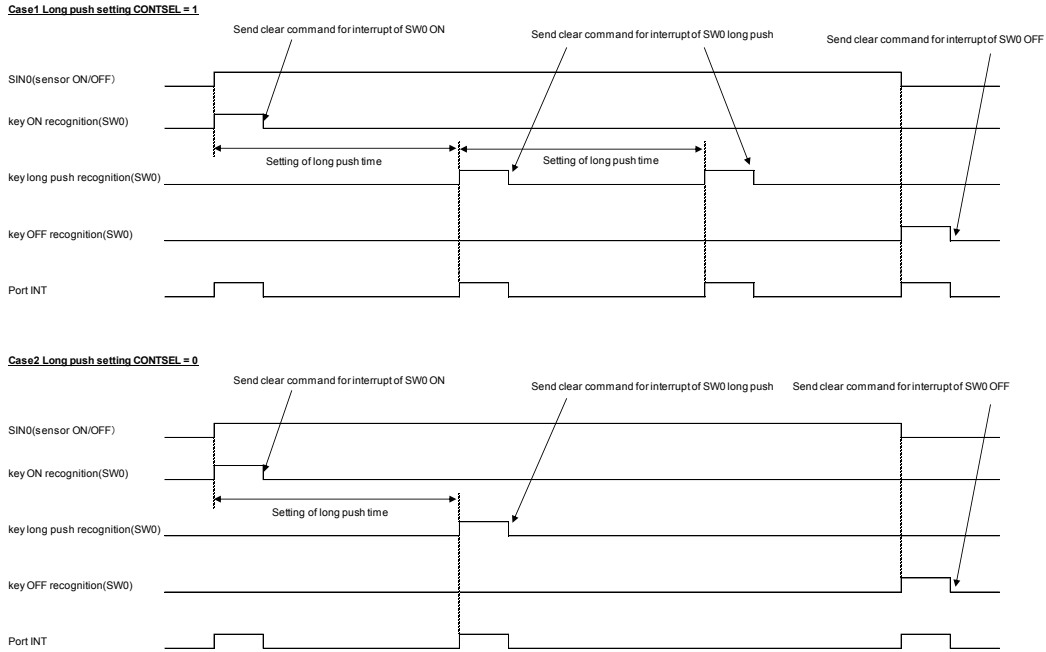

Figure 18. Interrupt of switch operation (1)

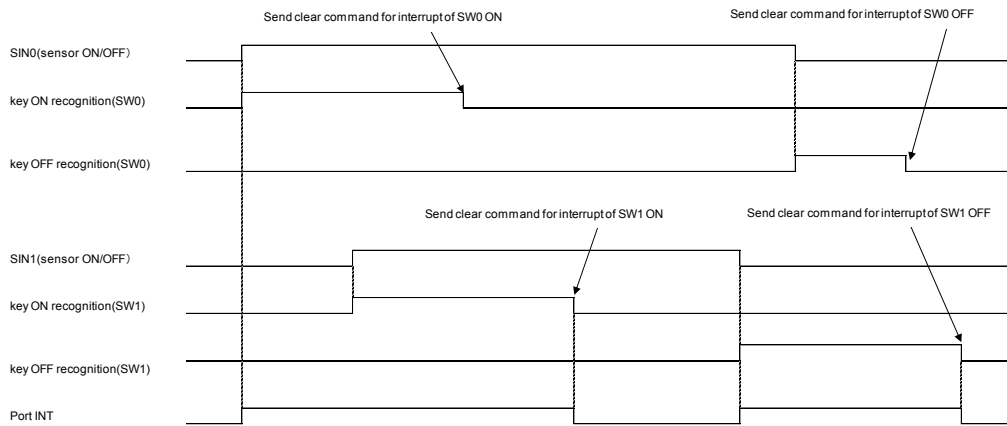

Figure 19. Interrupt of switch operation (2)

Interrupt of PWM continuous flashing

When PWM configuration is set to not always lights, PWM drive repeat as many times as the setting value. The interrupt is released at finishing PWM drive.

In the case that PWM always lights, the way to turn PWM off is to write '0' to the Control PWM function register which value is '1', and the interrupt is released at finishing PWM drive. However, if you restart the PWM timer before the PWM timer will not finish, the interrupt is not released.

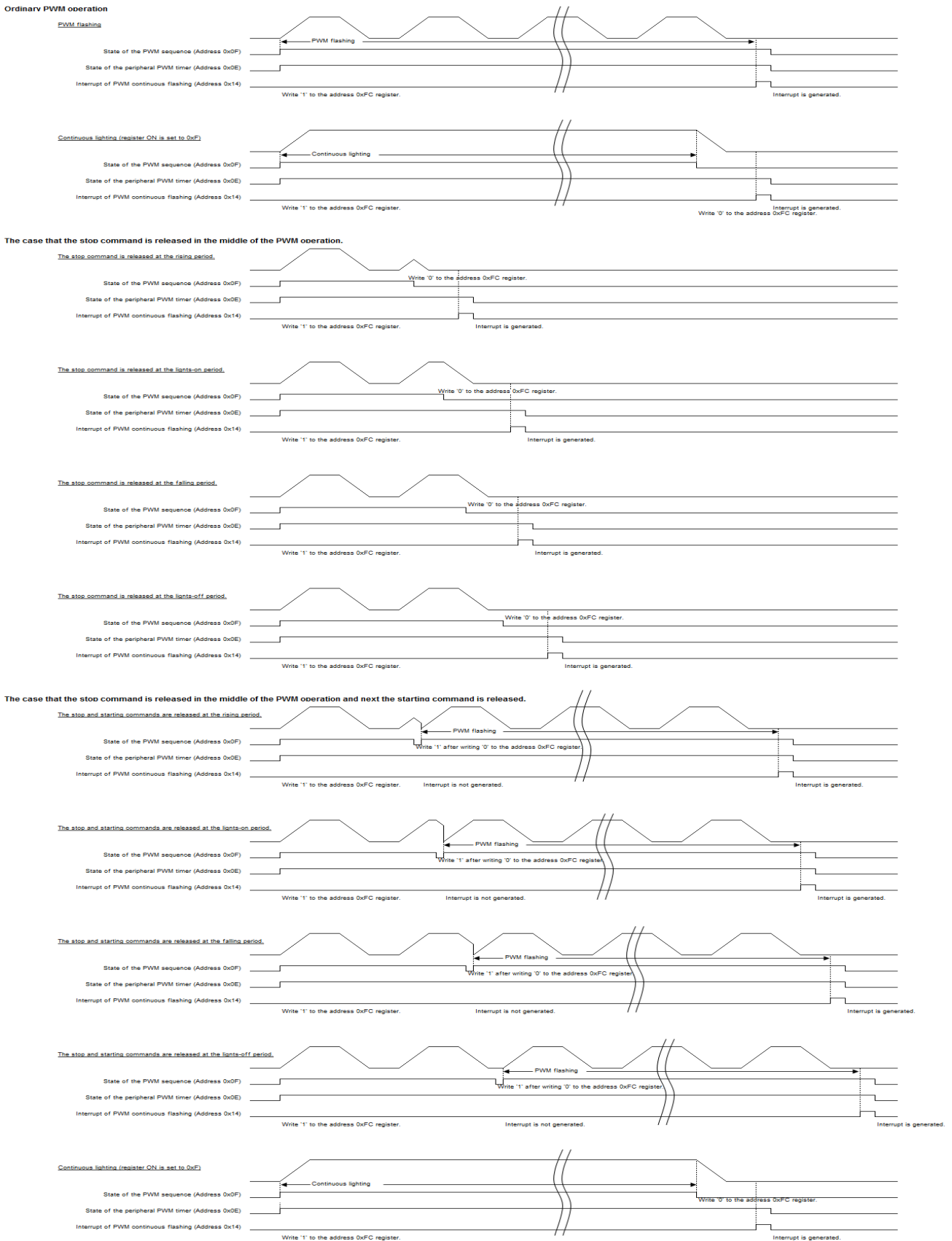

Figure 20. Interrupt of PWM drive



## Operational Notes

### 1. Reverse Connection of Power Supply

Connecting the power supply in reverse polarity can damage the IC. Take precautions against reverse polarity when connecting the power supply, such as mounting an external diode between the power supply and the IC's power supply terminals.

### 2. Power Supply Lines

Design the PCB layout pattern to provide low impedance supply lines. Separate the ground and supply lines of the digital and analog blocks to prevent noise in the ground and supply lines of the digital block from affecting the analog block. Furthermore, connect a capacitor to ground at all power supply pins. Consider the effect of temperature and aging on the capacitance value when using electrolytic capacitors.

### 3. Ground Voltage

Ensure that no pins are at a voltage below that of the ground pin at any time, even during transient condition.

### 4. Ground Wiring Pattern

When using both small-signal and large-current ground traces, the two ground traces should be routed separately but connected to a single ground at the reference point of the application board to avoid fluctuations in the small-signal ground caused by large currents. Also ensure that the ground traces of external components do not cause variations on the ground voltage. The ground lines must be as short and thick as possible to reduce line impedance.

### 5. Thermal Consideration

Should by any chance the power dissipation rating be exceeded the rise in temperature of the chip may result in deterioration of the properties of the chip. The absolute maximum rating of the Pd stated in this specification is when the IC is mounted on 74.2mm x 74.2mm x 1.6mm glass epoxy 1layer board (Copper foil area : 10.29mm<sup>2</sup>). In case of exceeding this absolute maximum rating, increase the board size and copper area to prevent exceeding the Pd rating.

### 6. Recommended Operating Conditions

These conditions represent a range within which the expected characteristics of the IC can be approximately obtained. The electrical characteristics are guaranteed under the conditions of each parameter.

### 7. Rush Current

When power is first supplied to the IC, it is possible that the internal logic may be unstable and inrush current may flow instantaneously due to the internal powering sequence and delays, especially if the IC has more than one power supply. Therefore, give special consideration to power coupling capacitance, power wiring, width of ground wiring, and routing of connections.

### 8. Operation Under Strong Electromagnetic Field

Operating the IC in the presence of a strong electromagnetic field may cause the IC to malfunction.

### 9. Testing on Application Boards

When testing the IC on an application board, connecting a capacitor directly to a low-impedance output pin may subject the IC to stress. Always discharge capacitors completely after each process or step. The IC's power supply should always be turned off completely before connecting or removing it from the test setup during the inspection process. To prevent damage from static discharge, ground the IC during assembly and use similar precautions during transport and storage.

### 10. Inter-pin Short and Mounting Errors

Ensure that the direction and position are correct when mounting the IC on the PCB. Incorrect mounting may result in damaging the IC. Avoid nearby pins being shorted to each other especially to ground, power supply and output pin. Inter-pin shorts could be due to many reasons such as metal particles, water droplets (in very humid environment) and unintentional solder bridge deposited in between pins during assembly to name a few.

### 11. Unused Input Terminals

Input terminals of an IC are often connected to the gate of a MOS transistor. The gate has extremely high impedance and extremely low capacitance. If left unconnected, the electric field from the outside can easily charge it. The small charge acquired in this way is enough to produce a significant effect on the conduction through the transistor and cause unexpected operation of the IC. So unless otherwise specified, unused input terminals should be connected to the power supply or ground line.

**12. Regarding the Input Pin of the IC**

In the construction of this IC, P-N junctions are inevitably formed creating parasitic diodes or transistors. The operation of these parasitic elements can result in mutual interference among circuits, operational faults, or physical damage. Therefore, conditions which cause these parasitic elements to operate, such as applying a voltage to an input pin lower than the ground voltage should be avoided. Furthermore, do not apply a voltage to the input terminals when no power supply voltage is applied to the IC. Even if the power supply voltage is applied, make sure that the input terminals have voltages within the values specified in the electrical characteristics of this IC.

**13. Ceramic Capacitor**

When using a ceramic capacitor, determine the dielectric constant considering the change of capacitance with temperature and the decrease in nominal capacitance due to DC bias and others.

**14. Area of Safe Operation (ASO)**

Operate the IC such that the output voltage, output current, and power dissipation are all within the Area of Safe Operation (ASO).

Ordering Information

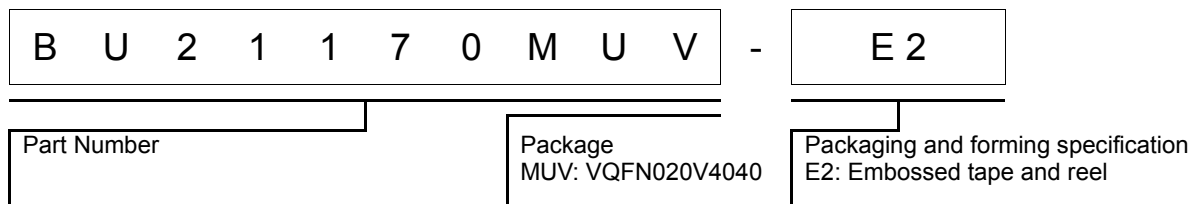

Marking Diagram

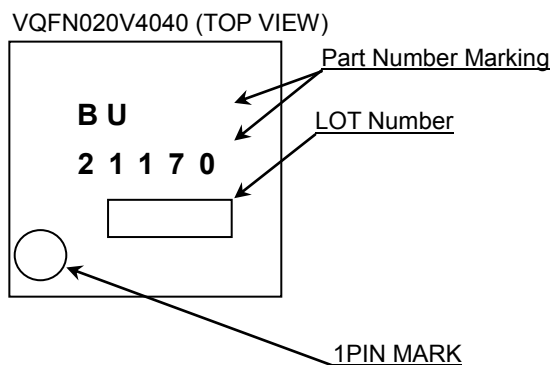

Physical Dimension, Tape and Reel Information

Package Name	VQFN020V4040
--------------	--------------

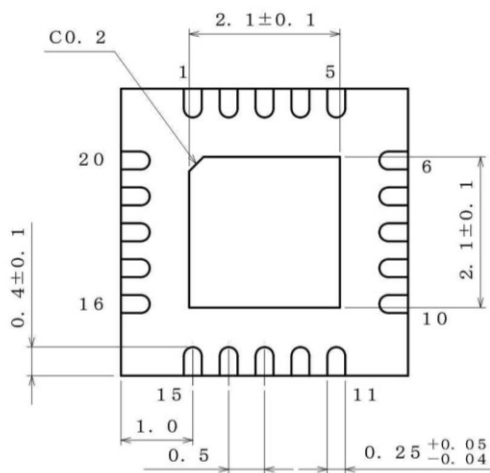
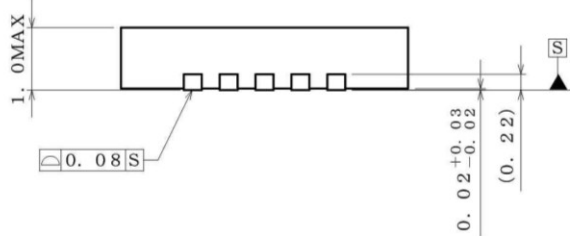
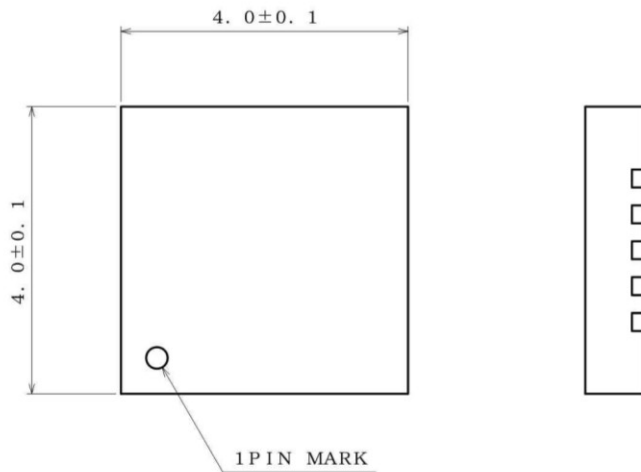

(UNIT : mm)  
 PKG : VQFN020V4040  
 Drawing No. EX474-5001-1

<Tape and Reel information>

Tape	Embossed carrier tape
Quantity	2500pcs
Direction of feed	E2 ( The direction is the 1pin of product is at the upper left when you hold reel on the left hand and you pull out the tape on the right hand )

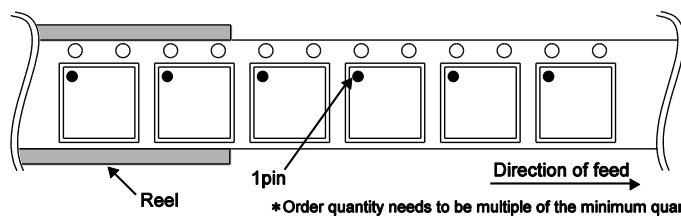

\*Order quantity needs to be multiple of the minimum quantity.

## Revision History

Date	Revision	Changes
31.Oct.2013	001	New Release
14.Jul.2016	002	<p>P3 Figure 6. Block Diagram Correct wiring error to the block PoR.</p> <p>P7 Correct clerical error (old) couth (new) touch</p> <p>P7 Correct clerical error (old) 'Detection continued touch' (new) 'Detection continuous touch'</p> <p>P13 Correct clerical error (old) the periodical : (new) the periodical calibration :</p> <p>P13 Correct clerical error (old) the periodical when (new) the periodical calibration when</p> <p>P14 Correct clerical error (old) Clear the INI interrupt (new) Clear the PERCAL interrupt</p> <p>P19 Correct clerical error (old) the initialization ha completed, (new) the initialization has been completed,</p> <p>P20 Correct clerical error in Figure 15. (old) Resister (new) Register</p>

# Notice

## Precaution on using ROHM Products

- Our Products are designed and manufactured for application in ordinary electronic equipments (such as AV equipment, OA equipment, telecommunication equipment, home electronic appliances, amusement equipment, etc.). If you intend to use our Products in devices requiring extremely high reliability (such as medical equipment <sup>(Note 1)</sup>, transport equipment, traffic equipment, aircraft/spacecraft, nuclear power controllers, fuel controllers, car equipment including car accessories, safety devices, etc.) and whose malfunction or failure may cause loss of human life, bodily injury or serious damage to property ("Specific Applications"), please consult with the ROHM sales representative in advance. Unless otherwise agreed in writing by ROHM in advance, ROHM shall not be in any way responsible or liable for any damages, expenses or losses incurred by you or third parties arising from the use of any ROHM's Products for Specific Applications.

(Note1) Medical Equipment Classification of the Specific Applications

JAPAN	USA	EU	CHINA
CLASS III	CLASS III	CLASS II b	CLASS III
CLASS IV		CLASS III	

- ROHM designs and manufactures its Products subject to strict quality control system. However, semiconductor products can fail or malfunction at a certain rate. Please be sure to implement, at your own responsibilities, adequate safety measures including but not limited to fail-safe design against the physical injury, damage to any property, which a failure or malfunction of our Products may cause. The following are examples of safety measures:
  - Installation of protection circuits or other protective devices to improve system safety
  - Installation of redundant circuits to reduce the impact of single or multiple circuit failure
- Our Products are designed and manufactured for use under standard conditions and not under any special or extraordinary environments or conditions, as exemplified below. Accordingly, ROHM shall not be in any way responsible or liable for any damages, expenses or losses arising from the use of any ROHM's Products under any special or extraordinary environments or conditions. If you intend to use our Products under any special or extraordinary environments or conditions (as exemplified below), your independent verification and confirmation of product performance, reliability, etc. prior to use, must be necessary:
  - Use of our Products in any types of liquid, including water, oils, chemicals, and organic solvents
  - Use of our Products outdoors or in places where the Products are exposed to direct sunlight or dust
  - Use of our Products in places where the Products are exposed to sea wind or corrosive gases, including Cl<sub>2</sub>, H<sub>2</sub>S, NH<sub>3</sub>, SO<sub>2</sub>, and NO<sub>2</sub>
  - Use of our Products in places where the Products are exposed to static electricity or electromagnetic waves
  - Use of our Products in proximity to heat-producing components, plastic cords, or other flammable items
  - Sealing or coating our Products with resin or other coating materials
  - Use of our Products without cleaning residue of flux (even if you use no-clean type fluxes, cleaning residue of flux is recommended); or Washing our Products by using water or water-soluble cleaning agents for cleaning residue after soldering
  - Use of the Products in places subject to dew condensation
- The Products are not subject to radiation-proof design.
- Please verify and confirm characteristics of the final or mounted products in using the Products.
- In particular, if a transient load (a large amount of load applied in a short period of time, such as pulse. is applied, confirmation of performance characteristics after on-board mounting is strongly recommended. Avoid applying power exceeding normal rated power; exceeding the power rating under steady-state loading condition may negatively affect product performance and reliability.
- De-rate Power Dissipation depending on ambient temperature. When used in sealed area, confirm that it is the use in the range that does not exceed the maximum junction temperature.
- Confirm that operation temperature is within the specified range described in the product specification.
- ROHM shall not be in any way responsible or liable for failure induced under deviant condition from what is defined in this document.

## Precaution for Mounting / Circuit board design

- When a highly active halogenous (chlorine, bromine, etc.) flux is used, the residue of flux may negatively affect product performance and reliability.
- In principle, the reflow soldering method must be used on a surface-mount products, the flow soldering method must be used on a through hole mount products. If the flow soldering method is preferred on a surface-mount products, please consult with the ROHM representative in advance.

For details, please refer to ROHM Mounting specification

### Precautions Regarding Application Examples and External Circuits

1. If change is made to the constant of an external circuit, please allow a sufficient margin considering variations of the characteristics of the Products and external components, including transient characteristics, as well as static characteristics.
2. You agree that application notes, reference designs, and associated data and information contained in this document are presented only as guidance for Products use. Therefore, in case you use such information, you are solely responsible for it and you must exercise your own independent verification and judgment in the use of such information contained in this document. ROHM shall not be in any way responsible or liable for any damages, expenses or losses incurred by you or third parties arising from the use of such information.

### Precaution for Electrostatic

This Product is electrostatic sensitive product, which may be damaged due to electrostatic discharge. Please take proper caution in your manufacturing process and storage so that voltage exceeding the Products maximum rating will not be applied to Products. Please take special care under dry condition (e.g. Grounding of human body / equipment / solder iron, isolation from charged objects, setting of Ionizer, friction prevention and temperature / humidity control).

### Precaution for Storage / Transportation

1. Product performance and soldered connections may deteriorate if the Products are stored in the places where:
  - [a] the Products are exposed to sea winds or corrosive gases, including Cl<sub>2</sub>, H<sub>2</sub>S, NH<sub>3</sub>, SO<sub>2</sub>, and NO<sub>2</sub>
  - [b] the temperature or humidity exceeds those recommended by ROHM
  - [c] the Products are exposed to direct sunshine or condensation
  - [d] the Products are exposed to high Electrostatic
2. Even under ROHM recommended storage condition, solderability of products out of recommended storage time period may be degraded. It is strongly recommended to confirm solderability before using Products of which storage time is exceeding the recommended storage time period.
3. Store / transport cartons in the correct direction, which is indicated on a carton with a symbol. Otherwise bent leads may occur due to excessive stress applied when dropping of a carton.
4. Use Products within the specified time after opening a humidity barrier bag. Baking is required before using Products of which storage time is exceeding the recommended storage time period.

### Precaution for Product Label

A two-dimensional barcode printed on ROHM Products label is for ROHM's internal use only.

### Precaution for Disposition

When disposing Products please dispose them properly using an authorized industry waste company.

### Precaution for Foreign Exchange and Foreign Trade act

Since concerned goods might be fallen under listed items of export control prescribed by Foreign exchange and Foreign trade act, please consult with ROHM in case of export.

### Precaution Regarding Intellectual Property Rights

1. All information and data including but not limited to application example contained in this document is for reference only. ROHM does not warrant that foregoing information or data will not infringe any intellectual property rights or any other rights of any third party regarding such information or data.
2. ROHM shall not have any obligations where the claims, actions or demands arising from the combination of the Products with other articles such as components, circuits, systems or external equipment (including software).
3. No license, expressly or implied, is granted hereby under any intellectual property rights or other rights of ROHM or any third parties with respect to the Products or the information contained in this document. Provided, however, that ROHM will not assert its intellectual property rights or other rights against you or your customers to the extent necessary to manufacture or sell products containing the Products, subject to the terms and conditions herein.

### Other Precaution

1. This document may not be reprinted or reproduced, in whole or in part, without prior written consent of ROHM.
2. The Products may not be disassembled, converted, modified, reproduced or otherwise changed without prior written consent of ROHM.
3. In no event shall you use in any way whatsoever the Products and the related technical information contained in the Products or this document for any military purposes, including but not limited to, the development of mass-destruction weapons.
4. The proper names of companies or products described in this document are trademarks or registered trademarks of ROHM, its affiliated companies or third parties.

**General Precaution**

1. Before you use our Products, you are requested to carefully read this document and fully understand its contents. ROHM shall not be in any way responsible or liable for failure, malfunction or accident arising from the use of any ROHM's Products against warning, caution or note contained in this document.
2. All information contained in this document is current as of the issuing date and subject to change without any prior notice. Before purchasing or using ROHM's Products, please confirm the latest information with a ROHM sales representative.
3. The information contained in this document is provided on an "as is" basis and ROHM does not warrant that all information contained in this document is accurate and/or error-free. ROHM shall not be in any way responsible or liable for any damages, expenses or losses incurred by you or third parties resulting from inaccuracy or errors of or concerning such information.



# Mouser Electronics

Authorized Distributor

Click to View Pricing, Inventory, Delivery & Lifecycle Information:

[ROHM Semiconductor:](#)

[BU21170MUV-E2](#)