

K-Nr.: 25984
 K-no.:

Ansteuerübertrager / Drive transformer

 Datum: 23.09.2011
 Date:

 Kunde:
 Customer

 Kd. Sach Nr.:
 Customers part no.:

 Seite 1 von 2
 Page of

 Maßbild (mm): Freimaßtoleranz DIN ISO 2768-c
 Mechanical outline General tolerances

 Anschlüsse:
 Connections:

 Toleranz des Stiftrasters ±0,2mm
 (Tolerances grid distance)

 ○ = Prüfmaß
 (test dimension)

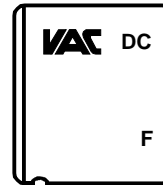
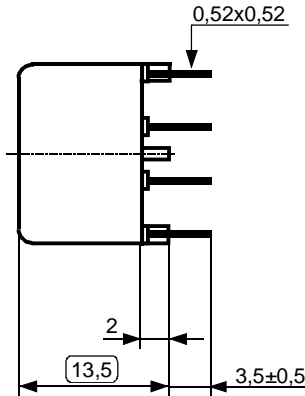
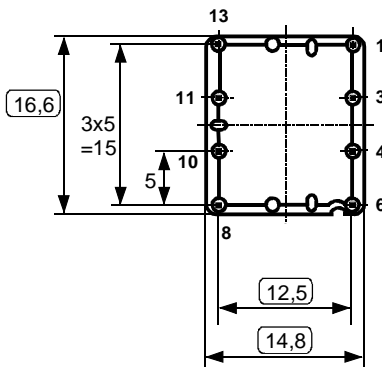
 DC=Date Code
 F=Factory

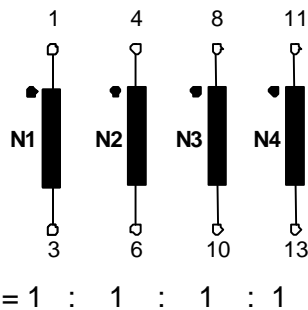
 Beschriftung:
 marking

 Anschlußschema:
 Schematic diagram

 Betriebsdaten/Charakteristische Daten (Nichtwerte):
 Operational data/characteristic data (nominal values):

 $U_1 = 12 \dots 18 \text{ V}$ $U_2 = 15 \text{ V}$ $U_3 = 15 \text{ V}$ $U_4 = 15 \text{ V}$
 $\int U dt \geq 130 \mu\text{Vs}$ $\tau \leq 50\%$ $P_{\text{ü}} = 8 \text{ W}$ $f = 100 \text{ kHz}$

 Inductance $L_1 = 842 \mu\text{H}$ (f=10 kHz)
 Stray inductance $L_{s1} = 5 \mu\text{H}$ (f=100 kHz, N2 shorted)

 Coupling capacitance $C_{k1-2+3+4} \approx 10 \text{ pF}$ (f=1 kHz)

 Insulation voltage N₁+N₂ vs N₃+N₄ reinforced: $U_{is,DC} = 1200 \text{ V}$
 N₃ vs N₄ reinforced: $U_{is,DC} = 1200 \text{ V}$

 Umgebungstemperatur / ambient temperature -40 ... +100°C
 Lagertemperatur / storage temperature -40 ... +85°C

Prüfung: (V: 100%-Test; AQL...: DIN ISO 2859-Teil1, SC = significant characteristics)

Inspection

- | | | | | | |
|----|------------|----------|--|--|--|
| 1) | (V) | M3014 | $U_{p,eff} = 4,6 \text{ kV}$ | 1s | N gegen / vs N |
| 2) | (AQL 1/S4) | M3011/4 | Einstellwerte / settings (N1):
Prüfwert / test value: | $U_E = 6.43\text{V}$
$I_p \leq 0.152 \text{ A}$ | $t_d = 20 \mu\text{s}$ $f_p = 1000 \text{ Hz}$ |
| 3) | (V) | M3011/6 | Polarität / Übersetzung:
polarity turns ratio: | Toleranz ± 2 % (± 0Wdg.)
tolerance ± 2 % (± 0 turns) | (SC) |
| 4) | (AQL 1/S4) | M3011/5: | $R_{Cu1} = 145 \text{ m}\Omega \pm 15 \%$
$R_{Cu3} = 145 \text{ m}\Omega \pm 15 \%$ | $R_{Cu2} = 145 \text{ m}\Omega \pm 15 \%$
$R_{Cu4} = 145 \text{ m}\Omega \pm 15 \%$ | |
| 5) | (Fix 05) | M3290: | Solderability test acc. to chapter 1 | | |
| 6) | (AQL 1/S4) | M3200: | Mechanical test | | |

Siehe Seite 2 / See page 2

Weitere Vorschriften:

Applicable documents:

Datum	Name	Index	Änderung
23.09.11	Leh.	81	Operational data / characteristic data, completed. Insulation voltage between N3 vs N4, ambient temperature +100°C, $\tau \leq 50\%$, $P_{\text{ü}} = 8 \text{ W}$, $f = 100 \text{ kHz}$, $L_1 = 842 \mu\text{H}$ (f=10 kHz). Lapidary change.

Hrsg.: KB-E editor	Bearb: Sc designer	KB-PM B: Yu check	freig.: HS released
-----------------------	-----------------------	----------------------	------------------------

**DATENBLATT / Specification****Sach Nr.: T60403-F4099-X010**
Item no.:

K-Nr.: 25984 K-no.:	Ansteuerübertrager / Drive transformer	Datum: 23.09.2011 Date:
Kunde: Customer	Kd. Sach Nr.: Customers part no.:	Seite 2 von 2 Page of

Typprüfung
Type testStoßspannungsprüfung in Anlehnung an M3064
HV transient test according to M3064

N1+N2 gegen/vs N3+N4

Einstellwerte: 1,2 μ s / 50 μ s-Kurvenform (waveform)
Settings $U_{P,max} = 4,8$ kV
 $R_i = 60 \Omega$ 3 Impulse im Abstand $t = 10$ Sekunden mit wechselnder Polarität
3 pulses in a cycle of $t = 10$ seconds with changing polarity

Hrsg.: KB-E editor	Bearb: Sc designer		KB-PM B: Yu check		freig.: HS released
-----------------------	-----------------------	--	----------------------	--	------------------------