

REVISIONS			
LTR	DESCRIPTION	DATE	APPROVED
B	RELEASED FOR PRODUCTION PER ECN T-013274	89 Nov. 29	93
C	REVISE PER DCR# T-22767	4/19/99	M.HIGGY

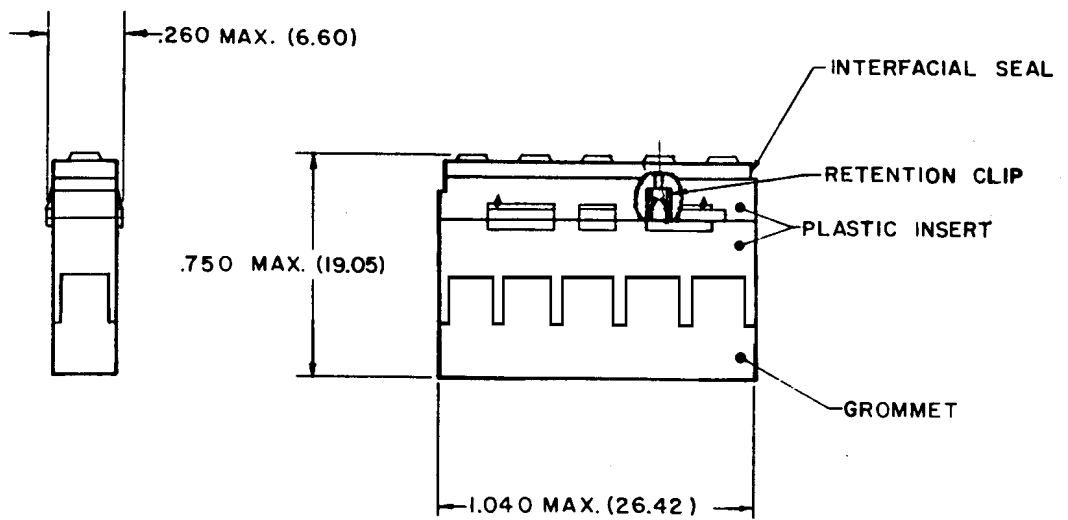
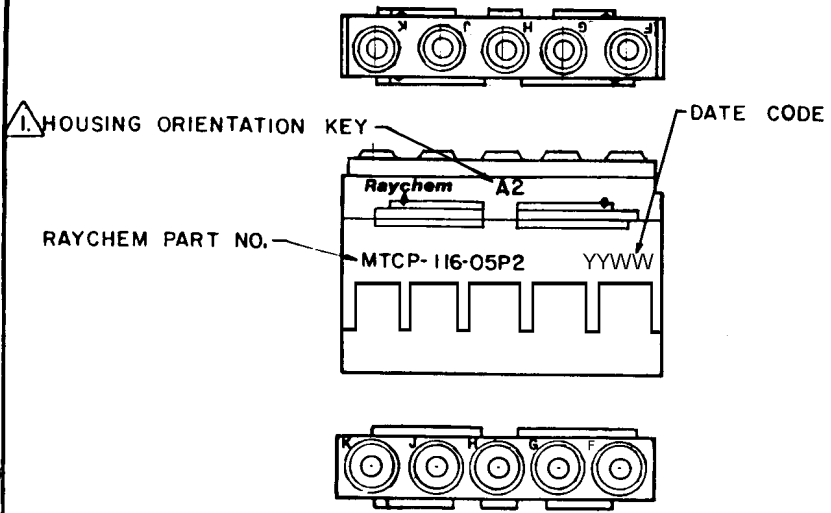

NOTES

- THIS INSERT IS DESIGNED FOR USE IN RAYCHEM CONNECTOR HOUSINGS MTC 100-JH1-XXX OR MTC 100-JH2-XXX (SEE RAYCHEM INFORMATION DRAWING D-659-0097 AND HOUSING SCD'S FOR FURTHER DETAILS)
- USE MIL-C-38999 SERIES 2 SIZE 16 CONTACTS OR EQUIVALENT. REFERENCE D-659-0097 FOR INSERTION/REMOVAL TOOLS, SEALING PLUGS AND CRIMP TOOLS WHEN APPLICABLE. THESE COMPONENTS ARE TO BE ORDERED SEPARATELY.
- GROMMET DESIGNED TO SEAL ON WIRES HAVING AN INSULATION DIAMETER OF .065 IN. (1.65 MM) TO .109 IN. (2.77 MM)
- PERFORMANCE:
THIS PRODUCT MEETS THE REQUIREMENTS OF RAYCHEM SPECIFICATION D-6115
- MATERIALS:
 A) PLASTIC INSERT HIGH GRADE POLYARYLENE THERMOPLASTIC
 B) GROMMET FLUOROSILICONE PER MIL-R-25988
 C) INTERFACIAL SEAL FLUOROSILICONE PER MIL-R-25988
 D) RETENTION CLIP BERYLLIUM COPPER 172 PER QQ-C-533

WEIGHT: 0.007 lbs [2.980 Grams] MAXIMUM.

If this document is printed it becomes uncontrolled.
Check with the web for latest revision.

SPECIFICATION CONTROL DRAWING

DRAWN	ALEXANDER	Raychem RAYCHEM CORPORATION 300 CONSTITUTION DRIVE MENLO PARK, CALIFORNIA 94025		
CHECKED	JS			
APPROVED	Blain 10-12-84	TITLE INSERT, PIN, SECONDARY 5 #16 CAVITIES POWER BLOCK CONNECTOR TEMPERATURE RATING 125°C MTC SERIES		
APPROVED	Xammun 10-24-84			
CAD NAME: T22767.TIF		SIZE	CODE IDENT. NO.	DWG. NO.
UNLESS OTHERWISE SPECIFIED DIMENSIONS ARE IN INCHES. METRIC DIMENSIONS ARE IN PARENTHESIS		A	06090	MTCP-116-05P2
		DO NOT SCALE THIS DRAWING		WEIGHT