

THIS DOCUMENT IS THE PROPERTY OF
KEYSTONE ELECTRONICS CORP. AND
SHALL NOT BE REPRODUCED, DISTRIBUTED
OR USED AS A BASIS FOR MANUFACTURE
WITHOUT PRIOR WRITTEN PERMISSION
FROM KEYSTONE ELECTRONICS CORP.

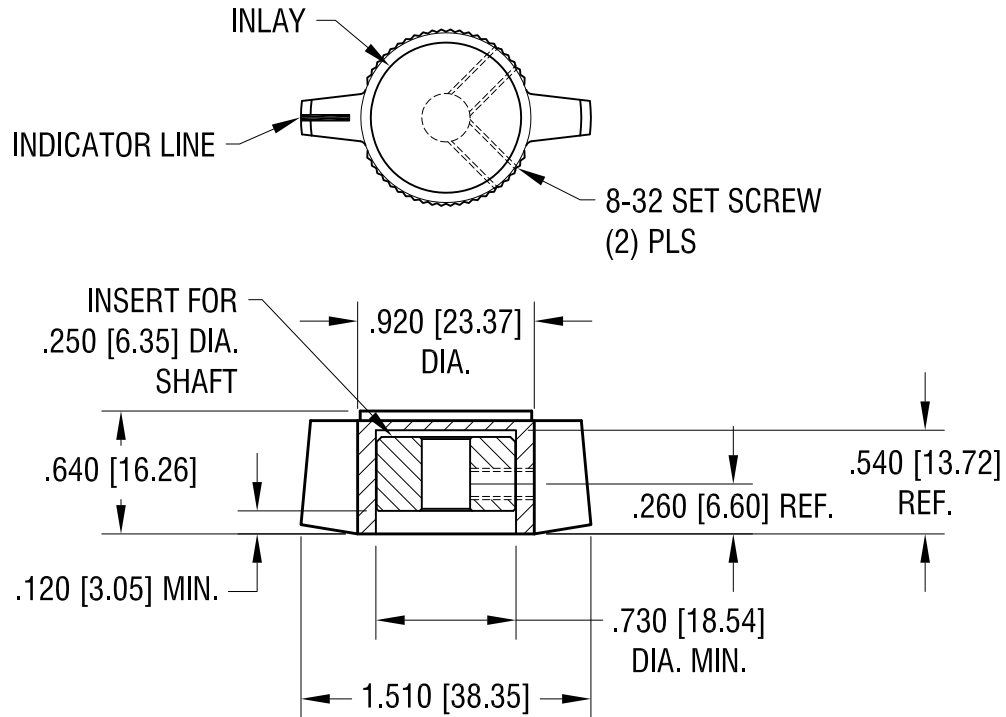
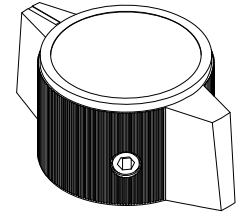

NOTES:

1. KNOB: MAT'L: ABS, BLACK
INSERT: MAT'L: BRASS, NICKEL PLATE
INLAY: MAT'L: SPUN ALUMINUM
2. INDICATOR PAINT LINE ON
TOP & SIDE OF KNOB BAR
3. SCREW: MAT'L- STEEL
FINISH- BLACK OXIDE

KEYSTONE ELECTRONICS CORP.			
www.keyelco.com • ASTORIA, N.Y. 11105-2017 • Tel (718) 956-8900			
PART NAME		KNOB	
MATERIAL		AS NOTED	
FINISH		DRN BY	DATE
AS NOTED		BOONE	1.8.07
		APP'D	SCALE
		LN	1X
TOLERANCES	INCH [MM]	CODE	DWG NO.
DECIMAL	± .015 [± 0.38]	C	8566
ANGULAR	± 1°		
UNLESS OTHERWISE SPECIFIED			

DATE	DESCRIPTION	REV.	
------	-------------	------	--