



Serial Digital Interface (SDI) MegaCore Function

User Guide



101 Innovation Drive
San Jose, CA 95134
www.altera.com

UG-SDI1005-16.0

Document last updated for Altera Complete Design Suite version:
Document publication date:

12.1
February 2013



© 2013 Altera Corporation. All rights reserved. ALTERA, ARRIA, CYCLONE, HARDCOPY, MAX, MEGACORE, NIOS, QUARTUS and STRATIX words and logos are trademarks of Altera Corporation and registered in the U.S. Patent and Trademark Office and in other countries. All other words and logos identified as trademarks or service marks are the property of their respective holders as described at www.altera.com/common/legal.html. Altera warrants performance of its semiconductor products to current specifications in accordance with Altera's standard warranty, but reserves the right to make changes to any products and services at any time without notice. Altera assumes no responsibility or liability arising out of the application or use of any information, product, or service described herein except as expressly agreed to in writing by Altera. Altera customers are advised to obtain the latest version of device specifications before relying on any published information and before placing orders for products or services.



Chapter 1. About This MegaCore Function

Features	1-1
Release Information	1-2
Device Family Support	1-2
General Description	1-3
OpenCore Plus Evaluation	1-5
Resource Utilization	1-6

Chapter 2. Getting Started

Design Flow	2-1
SDI Walkthrough	2-3
Creating a New Quartus II Project	2-3
Launching MegaWizard Plug-In Manager	2-4
Parameterizing	2-5
Setting Up Simulation	2-6
Generating Files	2-6
Simulating the Design	2-8
Testbench	2-8
Simulate with IP Functional Simulation Models	2-9
Simulating with the ModelSim Simulator	2-9
Simulating in Third-Party Simulation Tools Using NativeLink	2-10
Specifying Constraints	2-11
Single Channel	2-11
Multiple Channels	2-12
Compiling the Design	2-14
Programming a Device	2-14
Setting Up Licensing	2-15

Chapter 3. Functional Description

Block Description	3-2
Transmitter	3-2
HD-SDI LN Insertion	3-4
HD-SDI CRC Generation and Insertion	3-4
Scrambling and NRZI Coding	3-5
Transceiver Clock	3-5
Receiver	3-6
NRZI Decoding and Descrambling	3-8
Word Alignment	3-8
Video Timing Flags Extraction	3-9
RP168 Switching Compliance	3-9
HD-SDI LN Extraction	3-10
HD-SDI CRC Checking	3-10
Accessing Transceiver	3-10
Transceiver Clock	3-12
Transceiver—Soft-Logic Implementation	3-12
Transmitter	3-12
Transmitter Clocks	3-12
Receiver	3-13

Receiver Clocks	3–13
Transceiver—Stratix GX Devices	3–13
Transmitter Clocks	3–13
Receiver Clocks	3–15
Transmitter Transceiver Interface	3–16
Receiver Transceiver Interface	3–17
Transceiver—Arria GX, Arria II GX, Arria V, Cyclone IV GX, Cyclone V, Stratix II GX, Stratix IV GX, and Stratix V Devices	3–18
Transmitter Clocks	3–19
Receiver Clocks	3–22
Transmitter Transceiver Interface	3–23
Receiver Transceiver Interface	3–24
Locking to the Incoming SDI Stream	3–25
Transceiver Dynamic Reconfiguration for Dual Standard and Triple Standard Receivers	3–27
Transceiver Dynamic Reconfiguration with Channel Reconfiguration Mode—Arria II GX, HardCopy IV GX, Stratix GX, Stratix II GX, and Stratix IV GX	3–27
Transceiver Dynamic Reconfiguration with PLL Reconfiguration Mode—Cyclone IV GX	3–33
Reset Requirement During Reconfiguration	3–36
OpenCore Plus Time-Out Behavior	3–39
Signals	3–39
Parameters	3–56
MegaCore Verification	3–57

Chapter 4. SDI Audio IP Cores

SDI Audio Embed MegaCore Function	4–1
Functional Description	4–2
Parameters	4–3
Signals	4–4
Register Maps	4–8
SDI Audio Extract MegaCore Function	4–10
Functional Description	4–10
Parameters	4–11
Signals	4–12
Register Maps	4–15
Clocked Audio Input MegaCore Function	4–17
Parameters	4–17
Signals	4–17
Register Maps	4–18
Clocked Audio Output MegaCore Function	4–19
Parameters	4–19
Signals	4–19
Register Maps	4–20
AES Format	4–21
Avalon-ST Audio Interface	4–21
Instantiating the IP Cores	4–23
Simulating the Testbench	4–24
Design Example	4–25
Components	4–26
SDI Transmitter P0	4–26
SDI Duplex	4–26
Audio Extract	4–27
AES Output Module	4–27
AES Input Module	4–27

Audio Embed P0/P1	4-27
Video Pattern Generator P0/P1	4-27
Audio Pattern Generator	4-27
Ancillary Data Insertion P0/P1	4-27
Transceiver Dynamic Reconfiguration Control Logic	4-27
Hardware and Software Requirements	4-28
Hardware Setup	4-28
Running the Design Example	4-30
Transmit SD-SDI with Embedding of Audio Group 1	4-30
Transmit HD-SDI with Embedding of Audio Group 1 and 2	4-31
Transmit 3G-SDI Level A with Embedding of Audio Group 1, 2 and 3	4-32
Transmit 3G-SDI Level B with Embedding of Audio Group 1, 2, 3 and 4	4-32

Appendix A. Constraints

Specifying TimeQuest Timing Analyzer Constraints	A-1
Specify Clock Characteristics	A-4
Set Multicycle Paths	A-5
Specify Clocks that are Exclusive or Asynchronous	A-5
Define the Setup and Hold Relationship between 135-MHz Clocks and 337.5-MHz Zero-degree Clocks	A-6
Minimize Timing Skew	A-7
Constraints for the SDI Soft Transceiver	A-7
Non Cyclone Devices	A-8
Classic Timing Analyzer	A-8
TimeQuest Timing Analyzer	A-8
Cyclone Devices Only	A-9
Classic Timing Analyzer	A-9
TimeQuest Timing Analyzer	A-9

Appendix B. Clocking

Appendix C. Receive and Retransmit

Loopback FIFO Buffer	C-1
----------------------------	-----

Additional Information

Document Revision History	Info-1
How to Contact Altera	Info-3
Typographic Conventions	Info-3

This user guide describes the Altera® Serial Digital Interface (SDI) MegaCore® function and the accompanying SDI Audio IP cores.

The SDI MegaCore function implements a receiver, transmitter, or full-duplex SDI at standard definition (SD), high definition (HD), or 3 gigabits per second (3G). The SDI MegaCore function also supports dual standard (HD-SDI and SD-SDI) and triple standard (SD-SDI, HD-SDI, and 3G-SDI). These modes provide automatic receiver rate detection.

You can instantiate the SDI Audio IP cores with the SDI MegaCore function.

 For more information about the SDI Audio cores, refer to [“SDI Audio IP Cores” on page 4-1](#).

Features

[Table 1-1](#) lists the features of the SDI MegaCore function.

Table 1-1. SDI MegaCore Function Features

Feature	Description
Support	<ul style="list-style-type: none"> ■ Multiple SDI standards and video formats (refer to Table 1-5 and Table 1-6) ■ RP168 video switch line requirement ■ OpenCore Plus evaluation
Transmitter	<ul style="list-style-type: none"> ■ Cyclical redundancy check (CRC) encoding (HD only) ■ Line number (LN) insertion (HD only) ■ Word scrambling ■ Transmitter clock multiplexer (optional)
Receiver	<ul style="list-style-type: none"> ■ CRC decoding (HD only) ■ LN extraction (HD only) ■ Framing and extraction of video timing signals ■ Word alignment and descrambling
MegaWizard™ Plug-In Manager	<ul style="list-style-type: none"> ■ Easy-to-use parameter editor
IP functional simulation models	<ul style="list-style-type: none"> ■ Use in Altera-supported VHDL and Verilog HDL simulators

Release Information

Table 1–2 lists information about this release of the SDI MegaCore function.

Table 1–2. Release Information

Item	Description
Version	12.1
Release Date	January 2013
Ordering Code	IP-SDI
Product ID(s)	00AE (SDI MegaCore function) 00EF (SDI Audio cores)
Vendor ID	6AF7

 For more information about this release, refer to the [MegaCore IP Library Release Notes and Errata](#).

Altera verifies that the current version of the Quartus® II software compiles the previous version of each MegaCore function. The [MegaCore IP Library Release Notes and Errata](#) report any exceptions to this verification. Altera does not verify compilation with MegaCore function versions older than one release.

Device Family Support

Table 1–3 defines the device support levels for Altera IP cores.

Table 1–3. Altera IP Core Device Support Levels

FPGA Device Families	HardCopy Device Families
Preliminary support —The IP core is verified with preliminary timing models for this device family. The IP core meets all functional requirements, but might still be undergoing timing analysis for the device family. It can be used in production designs with caution.	HardCopy Companion —The IP core is verified with preliminary timing models for the HardCopy companion device. The IP core meets all functional requirements, but might still be undergoing timing analysis for the HardCopy device family. It can be used in production designs with caution.
Final support —The IP core is verified with final timing models for this device family. The IP core meets all functional and timing requirements for the device family and can be used in production designs.	HardCopy Compilation —The IP core is verified with final timing models for the HardCopy device family. The IP core meets all functional and timing requirements for the device family and can be used in production designs.

Table 1–4 shows the level of support offered by the SDI MegaCore function for each Altera device family.

Table 1–4. Device Family Support (Part 1 of 2)

Device Family	Support
Arria® GX	Final
Arria II (1)	Final
Arria V	Refer to the What's New in Altera IP page of the Altera website.

Table 1–4. Device Family Support (Part 2 of 2)

Device Family	Support
Cyclone®	Final (3)
Cyclone II (2)	Final
Cyclone III (2)	Final
Cyclone III LS (2)	Final
Cyclone IV GX (4)	Final
Cyclone V (5)	Refer to the What's New in Altera IP page of the Altera website.
HardCopy® III/ IV E	HardCopy Compilation
HardCopy IV GX	HardCopy Compilation
Stratix® (2)	Final
Stratix GX	Final
Stratix II (2)	Final
Stratix II GX	Final
Stratix III (2)	Final
Stratix IV (1)	Final
Stratix V (1)	Refer to the What's New in Altera IP page of the Altera website.
Other device families	No support

Notes to Table 1–4:

- (1) If you have only 27 MHz to drive the SDI MegaCore function in SD-SDI mode, you require an additional PLL to generate a 67.5-MHz reference clock.
- (2) The Cyclone series of devices, and Stratix, Stratix II, and Stratix III devices only support soft serializer /deserializer (SERDES).
- (3) Cyclone device support is limited to –6 speed grade devices.
- (4) Transceiver dynamic configuration with channel reconfiguration mode is not supported for dual and triple standard in EP4CGX110 and EP4CGX150 devices. Use transceiver dynamic reconfiguration with PLL reconfiguration mode instead.
- (5) The Cyclone V devices does not support the SDI Audio IP cores.

General Description

The Society of Motion Picture and Television Engineers (SMPTE) have defined an SDI that video system designers use widely as an interconnect between equipment in video production facilities.

The SDI MegaCore function can handle the following SDI data rates:

- 270 megabits per second (Mbps) SD-SDI, as defined by *SMPTE259M-1997 10-Bit 4:2:2 Component Serial Digital Interface*
- 1.5-Gbps HD-SDI, as defined by *SMPTE292M-1998 Bit-Serial Digital Interface for High Definition Television Systems*
- 3-Gbps SDI, as defined by *SMPTE425M-AB 2006 3Gb/s Signal/Data Serial Interface—Source Image Format Mapping*
- Preliminary support for dual link SDI, as defined by *SMPTE372M-Dual Link 1.5Gb/s Digital Interface for 1920×1080 and 2048×1080 Picture Formats*

- Dual standard support for 270-Mbps and 1.5-Gbps SDI
- Triple standard support for 270-Mbps, 1.5-Gbps, and 3-Gbps SDI
- SMPTE425M Level A support (direct source image formatting)
- SMPTE425M Level B support (dual link mapping)

Table 1–5 lists the SDI standard support for various devices.

Table 1–5. SDI Standard Support ⁽¹⁾

Device Family	SDI Standard					
	SD-SDI	HD-SDI	3G-SDI	HD-SDI Dual Link ⁽²⁾	Dual Standard	Triple Standard
Arria GX	✓	✓	✓	✓	✓	✓
Arria II GX	✓	✓	✓	✓	✓	✓
Arria V	✓	✓	✓	✓	✓	✓
Cyclone	✓	—	—	—	—	—
Cyclone II	✓	—	—	—	—	—
Cyclone III	✓	—	—	—	—	—
Cyclone IV GX (EP4CGX15, EP4CGX30)	✓	—	—	—	—	—
Cyclone IV GX (EP4CGX30 (F484), EP4CGX50, EP4CGX75, EP4CGX110, EP4CGX150)	✓	✓	✓	✓	✓	✓
Cyclone V ⁽³⁾	✓	✓	✓	✓	✓	✓
HardCopy IV GX	✓	✓	✓	✓	✓	✓
Stratix	✓	—	—	—	—	—
Stratix GX	✓	✓	—	✓	✓	—
Stratix II	✓	—	—	—	—	—
Stratix II GX	✓	✓	✓	✓	✓	✓
Stratix III	✓	—	—	—	—	—
Stratix IV ⁽⁴⁾	✓	✓	✓	✓	✓	✓
Stratix V ⁽⁴⁾	✓	✓	✓	✓	✓	✓

Notes to Table 1–5:

- (1) All standards, other than SD-SDI, require a transceiver based or “GX” device.
- (2) The HD-SDI dual link supports timing difference up to 40 ns between link A and link B, fulfilling the SMPTE372M requirement.
- (3) The 3G-SDI standard is not supported in Cyclone V devices with transceiver speed grade 7, due to the excessive data rate required. For more information about the Cyclone V device, refer to the *Overview for Cyclone V Device Family* chapter in volume 1 of the *Cyclone V Device Handbook*.
- (4) Only Stratix IV and Stratix V variants with transceivers support all SDI rates.

Table 1-6 lists the HD-SDI standard video format specification.

Table 1-6. HD-SDI Video Format Specification (1) (2)

SMPTE292M	Video Format	Sample per Active Line	Active Line per Frame	Sample per Total Line	Total Line per Frame	Frame Rate	SDI 11.1 Support
274M	1920 x 1080	1920	1080	2200	1125	60	Yes
				2640	1125	50	Yes
				2200	1125	30	Yes
				2640	1125	25	Yes
				2750	1125	24	Yes
296M	1280 x 720	1280	720	1650	750	60	Yes
				1980	750	50	Yes
				3300	750	30	Yes
				3960	750	25	Yes
				4125	750	24	Yes
260M	1920 x 1035	1920	1035	2200	1125	30	Yes
295M	1920 x 1080	1920	1080	2376	1250	25	Yes
				2376	1250	50	Yes

Notes to Table 1-6:

- (1) The video formats support 4:2:2(YC_BC_R)/10-bit, 4:4:4(RGB)/(YC_BC_R), 4:4:4:4 (RGB+A)/(YC_BC_R+A)/10-bit, 4:4:4(YC_BC_R)/12-bit, 4:4:4(RGB)/12-bit, and 4:2:2 (YC_BC_R)/12-bit mapping structures.
- (2) 3G-SDI is similar to HD-SDI except the data bit rate is twice that of HD-SDI or approximately 3 Gbps.

OpenCore Plus Evaluation

With Altera’s free OpenCore Plus evaluation feature, you can perform the following actions:

- Simulate the behavior of a megafunction (Altera MegaCore function or AMPPSM megafunction) within your system.
- Verify the functionality of your design and quickly evaluate its size and speed with ease.
- Generate time-limited device programming files for designs that include MegaCore functions.
- Program a device and verify your design in hardware.

You are required to obtain a license for the MegaCore function only when you are completely satisfied with its functionality and performance, and want to take your design to production.



For more information about OpenCore Plus hardware evaluation using the SDI, refer to “OpenCore Plus Time-Out Behavior” on page 3-39 and *AN 320: OpenCore Plus Evaluation of Megafunctions*.

Resource Utilization

Table 1-7 lists the typical resource utilization for various parameters with the Quartus II software, version 11.1.

 The resource utilization of the MegaCore function is based on the bidirectional interface settings unless otherwise specified.

Table 1-7. Resource Utilization (Part 1 of 2)

Device	Video Standard	LEs	Combinational ALUTs	Logic Registers
Arria GX	SD-SDI	—	834	640
	HD-SDI	—	919	683
	3G-SDI	—	1,161	865
	Dual link HD-SDI	—	1,906	1,423
	Dual standard receiver	—	1,188	831
	Dual standard transmitter	—	247	185
	Triple standard	—	1,794	1,215
Arria II GX	SD-SDI	—	839	680
	HD-SDI	—	978	833
	3G HD-SDI	—	1,259	1,015
	Dual-Link HD-SDI	—	2,029	1,711
	Dual standard receiver	—	1,257	926
	Dual standard transmitter	—	267	180
	Triple standard	—	1,891	1,305
Arria V	SD-SDI	—	1,189	920
	HD-SDI	—	1,185	910
	3G-SDI	—	1,444	1,142
	Dual link HD-SDI	—	2,446	1,880
	Dual standard receiver	—	1,605	1,175
	Dual standard transmitter	—	349	269
	Triple standard	—	2,273	1,677
Cyclone	SD-SDI	875	—	—
Cyclone II	SD-SDI	867	—	—
Cyclone III	SD-SDI	874	—	—
Cyclone III LS	SD-SDI	929	—	—
Cyclone IV GX (EP4CGX15, EP4CGX30)	SD-SDI	916	—	—

Table 1-7. Resource Utilization (Part 2 of 2)

Device	Video Standard	LEs	Combinational ALUTs	Logic Registers
Cyclone IV GX (EP4CGX50, EP4CGX75, EP4CGX110, and EP4CGX150)	SD-SDI	—	1,129	671
	HD-SDI	—	1,164	670
	3G-SDI	—	1,409	790
	Dual link HD-SDI	—	2,515	1,467
	Dual standard receiver	—	1,479	755
	Dual standard transmitter	—	364	229
	Triple standard	—	2,235	1,121
Cyclone V	SD-SDI	—	1,140	832
	HD-SDI	—	1,122	808
	3G-SDI	—	1,402	997
	Dual link HD-SDI	—	2,351	1,696
	Dual standard receiver	—	1,539	1,042
	Dual standard transmitter	—	352	260
	Triple standard	—	2,217	1,508
Stratix	SD-SDI	875	—	—
Stratix II	SD-SDI	—	581	533
Stratix III	SD-SDI	—	602	565
Stratix GX	SD-SDI	1,182	—	—
	HD-SDI	1,316	—	—
	Dual link HD-SDI	2,703	—	—
	Dual standard	1,819	—	—
Stratix II GX	SD-SDI	—	834	640
	HD-SDI	—	919	683
	3G-SDI	—	1,161	865
	Dual link HD-SDI	—	1,906	1,423
	Dual standard receiver	—	1,188	831
	Dual standard transmitter	—	247	185
	Triple standard	—	1,794	1,215
Stratix IV GX	SD-SDI	—	839	680
	HD-SDI	—	978	833
	3G-SDI	—	1,259	1,015
	Dual link HD-SDI	—	2,029	1,711
	Dual standard receiver	—	1,257	926
	Dual standard transmitter	—	267	180
	Triple standard	—	1,891	1,305
Stratix V	SD-SDI	—	913	707
	HD-SDI	—	955	703
	3G-SDI	—	1,126	823
	Dual link HD-SDI	—	2,049	1,522

Design Flow

To evaluate the SDI MegaCore function using the OpenCore Plus feature, follow these steps in your design flow:

1. Obtain and install the SDI MegaCore function.

The SDI MegaCore function is part of the MegaCore IP Library, which is distributed with the Quartus II software and downloadable from the Altera website at www.altera.com.

 For system requirements and installation instructions, refer to *Altera Software Installation & Licensing*.

Figure 2–1 shows the directory structure after you install the SDI MegaCore function, where *<path>* is the installation directory. The default installation directory on Windows is `c:\altera\<version>`; on Linux, it is `/opt/altera<version>`.

Figure 2-1. Directory Structure

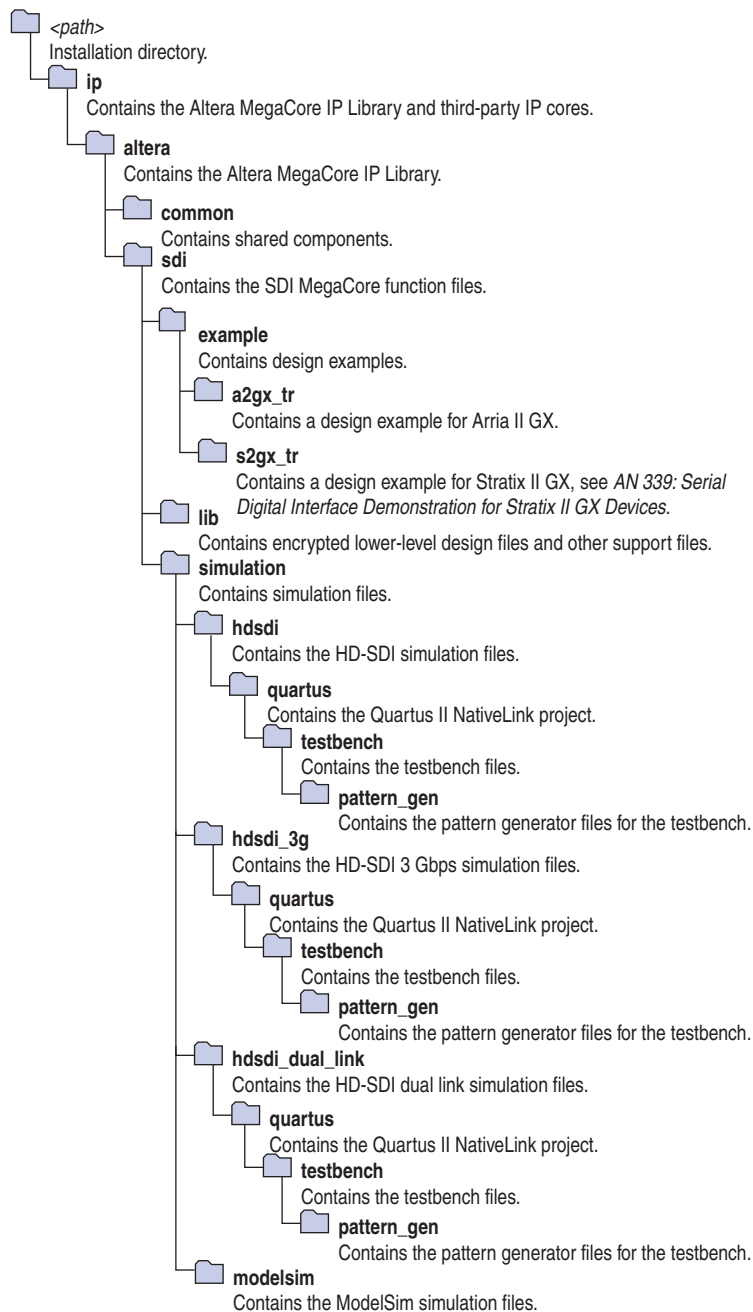

1. Create a custom variation of the SDI MegaCore function.
2. Implement the rest of your design using the design entry method of your choice.
3. Use the IP functional simulation model to verify the operation of your design.

 For more information on IP functional simulation models, refer to the *Simulating Altera Designs* chapter in volume 3 of the *Quartus II Handbook*.

4. Use the Quartus II software to compile your design.



You can also generate an OpenCore Plus time-limited programming file, which you can use to verify the operation of your design in hardware.

5. Purchase a license for the SDI MegaCore function.

After you have purchased a license for the SDI MegaCore function, follow these additional steps:

1. Set up licensing.
2. Generate a programming file for the Altera device or devices on your board.
3. Program the Altera device or devices with the completed design.

SDI Walkthrough

This walkthrough explains how to create an SDI design using the MegaWizard Plug-In Manager and the Quartus II software. After you generate a custom variation of the SDI MegaCore function, you can incorporate it into your overall project.



You can alternatively use the IP Advisor to help start your SDI MegaCore design. On the Quartus II Tools menu, point to **Advisors**, and then click **IP Advisor**. The IP Advisor guides you through a series of recommendations for selecting, parameterizing, evaluating, and instantiating an SDI MegaCore function into your design. It then guides you through a complete Quartus II compilation of your project.



This walkthrough requires the following steps:

1. “Creating a New Quartus II Project”
2. “Launching MegaWizard Plug-In Manager”
3. “Parameterizing”
4. “Setting Up Simulation”
5. “Generating Files”

Creating a New Quartus II Project

You must create a new Quartus II project with the **New Project Wizard**, which specifies the working directory for the project, assigns the project name, and designates the name of the top-level design entity. To create a new project, follow these steps:

1. Choose **Programs > Altera > Quartus II <version>** (Windows Start menu) to run the Quartus II software. Alternatively, you can use the Quartus II Web Edition software.
2. On the File menu, click **New Project Wizard**.
3. Click **Next** in the **New Project Wizard: Introduction** page (the introduction page does not display if you turned it off previously).

4. In the **New Project Wizard: Directory, Name, Top-Level Entity** page, enter the following information:
 - a. Specify the working directory for your project. For example, this walkthrough uses the `c:\altera\projects\sdi_project` directory.
 The Quartus II software automatically specifies a top-level design entity that has the same name as the project. This walkthrough assumes that the names are the same.
 - b. Specify the name of the project. This walkthrough uses **project** for the project name.
5. Click **Next** to close this page and display the **New Project Wizard: Add Files** page.
 When you specify a directory that does not already exist, a message prompts you to create a specified directory. Click **Yes** to create the directory.
6. If you installed the MegaCore IP Library in a different directory from where you installed the Quartus II software, you must add the user libraries:
 - a. Click **User Libraries**.
 - b. Type `<path>\ip` into the **Library name** field, where `<path>` is the directory in which you installed the SDI.
 - c. Click **Add to** add the path to the Quartus II project.
 - d. Click **OK** to save the library path in the project.
7. Click **Next** to close this page and display the **New Project Wizard: Family & Device Settings** page.
8. On the **New Project Wizard: Family & Device Settings** page, choose the target device family in the **Family** list.
9. The remaining pages in the **New Project Wizard** are optional. Click **Finish** to complete the Quartus II project.

Launching MegaWizard Plug-In Manager

To launch the MegaWizard Plug-In Manager in the Quartus II software, follow these steps:

1. On the Tools menu, click **MegaWizard Plug-In Manager**.
 For more information about how to use the MegaWizard Plug-In Manager, refer to Quartus II Help.
2. Specify that you want to create a new custom megafunction variation and click **Next**.
3. Expand the **Interfaces > SDI** folder and click **SDI <version>**.
4. Select the output file type for your design; the wizard supports VHDL and Verilog HDL.

5. The MegaWizard Plug-In Manager shows the project path that you specified in the **New Project Wizard**. Append a variation name for the MegaCore function output files `<project path>\<variation name>`.
6. Click **Next** to display the **Parameter Settings** page for the SDI MegaCore function.



You can change the page that the MegaWizard Plug-In Manager displays by clicking **Next** or **Back** at the bottom of the dialog box. You can move directly to a named page by clicking the **Parameter Settings**, **EDA**, or **Summary** tab.

Also, you can directly display individual parameter settings by clicking on the **Protocol Options**, **Transceiver Options**, or **Receiver/Transmitter Options** tab.

Parameterizing

To parameterize your MegaCore function, follow these steps:

1. Select the video standard. Some of the standards may be grayed out, because they are not supported on the currently selected device family.
2. Select **Bidirectional**, **Receiver**, or **Transmitter** interface direction.
3. Click the **Transceiver Options** tab.
4. Under **Transceiver and Protocol**, click **Generate transceiver and protocol blocks**.
5. For SD-SDI only, turn on **Use soft logic for transceiver** to implement the transceiver in logic, rather than using Stratix GX, Stratix II GX or Stratix IV GX transceivers.
6. Select the starting channel number.
7. Turn on **Use PLL reconfiguration for transceiver dynamic reconfiguration** if you select an EP4CGX110 or EP4CGX150 device for Cyclone IV GX using dual and triple standards. You may turn on this option for other Cyclone IV GX devices but it is not recommended.
8. Turn on **Enable TX PLL select for 1/1.000 and 1/1.001 data rate reconfiguration** if your design requires two serial input clocks to the TX block.



This feature is only available for the Arria II, Stratix IV GX, and HardCopy IV GX device families.

9. Click the **Receiver/Transmitter Options** tab.
10. Turn on the required receiver options.
11. Turn on the required transmitter options.
12. Click **Next** (or the **EDA** tab) to display the **EDA** page.



For more information about parameters, refer to [“Parameters” on page 3–56](#) and, for more information about the protocol options, refer to [Table 3–20 on page 3–56](#). For more information about the transceiver options, refer to [Table 3–21 on page 3–56](#). For more information about the receiver/transmitter options, refer to [Table 3–22 on page 3–57](#).

Setting Up Simulation

An IP functional simulation model is a cycle-accurate VHDL or Verilog HDL model produced by the Quartus II software. The model allows for fast functional simulation of IP using industry-standard VHDL and Verilog HDL simulators.



You may only use these models for simulation and expressly not for synthesis or any other purposes. Using these models for synthesis creates a nonfunctional design.

To generate an IP functional simulation model for your MegaCore function, follow these steps:

1. Turn on **Generate simulation model**.
2. Some third-party synthesis tools can use a netlist that contains only the structure of the MegaCore function, but not detailed logic, to optimize performance of the design that contains the MegaCore function. If your synthesis tool supports this feature, turn on **Generate netlist**.
3. Click **Next** (or the **Summary** tab) to display the **Summary** page.

Generating Files

You can use the check boxes on the **Summary** page to enable or disable the generation of specified files. A gray checkmark indicates a file that is automatically generated; a red checkmark indicates an optional file.

You can click **Back** to display the previous page, or click **Parameters Settings**, **EDA**, or **Summary**, to change any of the MegaWizard options.

To generate the files, follow these steps:

1. Turn on the files you wish to generate.



At this stage, you can still click **Back** to display any of the other pages in the MegaWizard Plug-In Manager to change any of the parameters.

2. To generate the specified files and close the MegaWizard Plug-In Manager, click **Finish**.



The generation phase may take several minutes to complete.



The Quartus II IP File (**.qip**) is a file generated by the parameter editor, and contains information about the generated IP core. You are prompted to add this **.qip** file to the current Quartus II project at the time of file generation. In most cases, the **.qip** file contains all of the necessary assignments and information required to process the core or system in the Quartus II compiler. Generally, a single **.qip** file is generated for each MegaCore function or system in the Quartus II compiler.

3. Click **Exit** to close the **Generation** window.

Table 2–1 describes the generated files and other files that may be in your project directory. The names and types of files specified in the MegaWizard Plug-In Manager report vary based on whether you created your design with VHDL or Verilog HDL.

Table 2–1. Generated Files

Extension	Description
<variation name>.v or .vhd	A MegaCore function variation file, which defines a VHDL or Verilog HDL description of the custom MegaCore function. Instantiate the entity defined by this file inside of your design. Include this file when compiling your design in the Quartus II software.
<variation name>.cmp	A VHDL component declaration file for the MegaCore function variation. Add the contents of this file to any VHDL architecture that instantiates the MegaCore function.
<variation name>.bsf	Quartus II symbol file for the MegaCore function variation. You can use this file in the Quartus II block diagram editor.
<variation name>.html	MegaCore function report file.
<variation name>.ppf	This XML file describes the MegaCore pin attributes to the Quartus II Pin Planner. MegaCore pin attributes include pin direction, location, I/O standard assignments, and drive strength. If you launch IP Toolbench outside of the Pin Planner application, you must explicitly load this file to use Pin Planner.
<variation name>_sdi.sdc	Contains timing constraints for your SDI variation.
<variation name>_constraints.tcl	Quartus II file that sets the Quartus II to use TimeQuest timing analyzer and patches the generated .sdc script with a new clock name. If your top-level design clock pin names do not match the default clock pin names or a prefixed version, edit the assignments in this file.
<variation name>.vo or .vho	VHDL or Verilog HDL IP functional simulation model.
<variation name>_bb.v	A Verilog HDL black-box file for the MegaCore function variation. Use this file when using a third-party EDA tool to synthesize your design.
<variation name>.qip	Contains Quartus II project information for your MegaCore function variations.

You can now integrate your custom MegaCore function variation into your design, simulate, and compile.

Simulating the Design

This section describes the following simulation techniques:

- Simulate with IP Functional Simulation Models
- Simulating with the ModelSim Simulator
- Simulating in Third-Party Simulation Tools Using NativeLink

Testbench

In general, all testbenches are constructed in such a way that the serial transmit data is looped back to receiver. [Figure 2-2](#) shows how the serial transmit data is looped back to the receiver in the testbench.

Figure 2-2. General Simulation Testbench

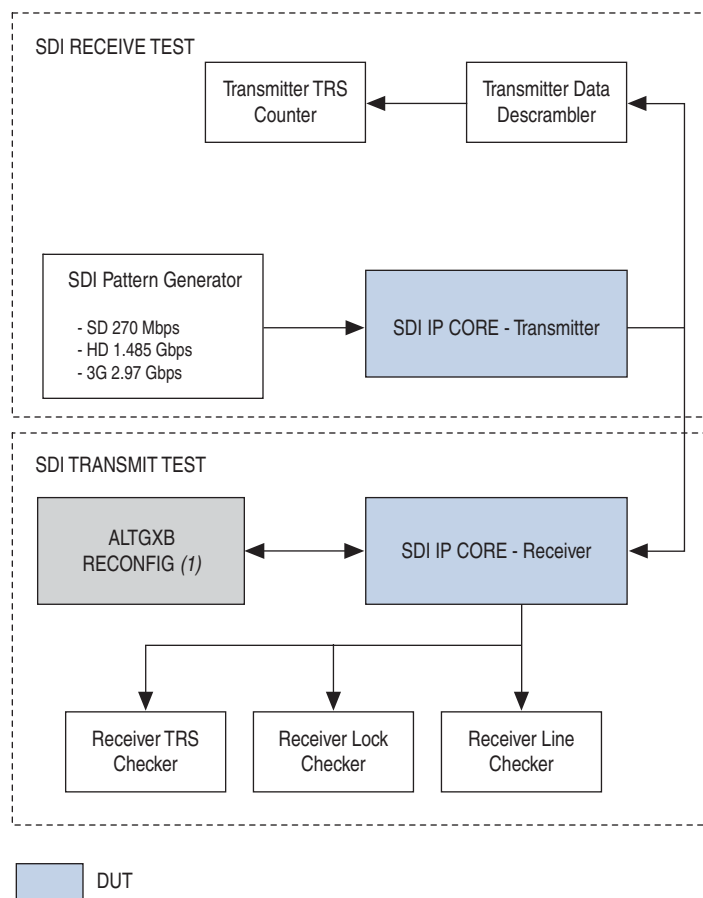

Note to Figure 2-2:

(1) For dual or triple standard only.

A testbench basically consists of transmit test and receive test. The transmit test accepts the same serial data as the receive device under test (DUT), deserializes and decodes the transmitted data, and computes the number of time reference signals (TRS) seen. The receive test verifies the features that are supported by the SDI receiver by monitoring the received data, status bits, line numbering and other related features.

For dual and triple standard modes, the SDI receiver requires reconfiguration. The SDI receiver reconfigures using transceiver dynamic reconfiguration to perform autodetection and locking to different SDI video standards. For more details about transceiver dynamic reconfiguration, refer to [“Transceiver Dynamic Reconfiguration for Dual Standard and Triple Standard Receivers”](#) on page 3–27.

Simulate with IP Functional Simulation Models

You can simulate your design using the MegaWizard-generated VHDL and Verilog HDL IP functional simulation models.

You can use the IP functional simulation model with any Altera-supported VHDL or Verilog HDL simulator.

To use the IP functional simulation model that you created in [“Setting Up Simulation”](#) on page 2–6, create a suitable testbench.



For more information about IP functional simulation models, refer to the [Simulating Altera Designs](#) chapter in volume 3 of the *Quartus II Handbook*.

Simulating with the ModelSim Simulator

For Arria and Stratix series of devices, Altera provides two fixed testbenches as examples in the `simulation\modelsim\<video standard>\modelsim` directory, where `<video standard>` is `hdsdi` or `hdsdi_dual_link`. The testbenches instantiate the design and test the HD-SDI or dual link mode of operation. To use one of these testbenches with the ModelSim®-Altera simulator, follow these steps:

1. In a text editor, open the simulation batch file, `simulation\modelsim\<video standard>\modelsim\sdi_sim.bat`. Edit it to point to your installation of the ModelSim-Altera simulator and the Quartus II software, and edit the path:

```
set PATH = %MODELSIM_DIR%\win32aloem
set QUARTUS_ROOTDIR=c:\altera\81\quartus
```

For example, edit `QUARTUS_ROOTDIR=/tools/acds/11.0/157/linux32/quartus`.



Where `<video standard>` is `hdsdi` or `hdsdi_dual_link`.

2. Start the ModelSim-Altera simulator.
3. Run `sdi_sim.bat` in the `simulation\modelsim\<video standard>\modelsim` directory. This file compiles the design and starts the ModelSim-Altera simulator. A selection of signals appears on the waveform viewer. The simulation runs automatically, providing a pass/fail indication on completion.

For Cyclone IV GX devices, Altera provides two new fixed testbenches in the `simulation\modelsim\<video standard>\<DPRIO mode>\modelsim` directory, where `<video standard>\<DPRIO mode>` is `trsvdi_c4gx\channel_reconfig` or `trsvdi_c4gx\pll_reconfig`. The testbenches instantiate the design and test the triple standard mode of operation using Cyclone IV GX devices. The testbenches also demonstrate the transceiver dynamic reconfiguration with channel and phase-locked loop (PLL) reconfiguration modes. To use one of these testbenches with the ModelSim-Altera simulator, follow these steps:

1. In a text editor, open the simulation `.do` file, `simulation\modelsim\<video standard>\<DPRIO mode>\modelsim\sdi_sim.do`. Edit it to point to your installation of the ModelSim-Altera simulator, and edit the path:

```
set QUARTUS_ROOTDIR = C:\altera\<version>\quartus
```

 Where `<version>` is the version of the Quartus II software you are using.

2. Start the ModelSim-Altera simulator.
3. Run `sdi_sim.do` in the `simulation\modelsim\<video standard>\<DPRIO mode>\modelsim` directory. This file compiles the design and starts the ModelSim-Altera simulator. A selection of signals appears on the waveform viewer.

To test the transmitter operation, the testbench generates a reference clock and parallel video data. The design encodes and serializes this parallel video data. The serial output is sampled, non-return to zero inverted (NRZI) decoded, descrambled, and then reconstructed into parallel form. The testbench detects the presence of TRS tokens (end of active video (EAV) and start of active video (SAV)) in the output to check the correct operation.

To test the receiver operation, the testbench connects the serial transmitter data to the receiver input. The testbench checks that the receiver achieves word alignment and verifies that the extracted LN is correct.

Simulating in Third-Party Simulation Tools Using NativeLink

You can perform a simulation in a third-party simulation tool from within the Quartus II software, using NativeLink.

-  For more information about NativeLink, refer to the *Simulating Altera Designs* chapter in volume 3 of the *Quartus II Handbook*.

Altera provides the following three Quartus II projects for use with NativeLink in the `ip\altera\sdi\simulation` directory:

- HD-SDI in the `hdsdi` directory
- HD-SDI 3 Gbps in the `hdsdi_3g` directory
- HD-SDI dual link in the `hdsdi_dual_link` directory
- Triple standard SDI in the `trsvdi` directory

To set up simulation in the Quartus II software using NativeLink, follow these steps:

1. On the File menu, click **Open Project**. Browse to the desired directory: **hdsdi**, **hdsdi_3g**, **hdsdi_dual_link**, or **trsd**.
2. Open **sdi_sim.qpf**.
3. Check that the absolute path to your third-party simulator executable is set. On the Tools menu, click **Options** and select **EDA Tools Options**.
4. On the Processing menu, point to **Start** and click **Start Analysis & Elaboration**.
5. On the Tools menu, point to **Run EDA Simulation Tool** and click **EDA RTL Simulation**.

Specifying Constraints

You must apply the Altera-provided timing constraint file in Synopsys Design Constraints File (.sdc) format and the additional Tcl Script File (.tcl) to ensure the SDI MegaCore function meets the design timing requirements.

To add the .sdc file to your project, click **Add/Remove Files in Project** on the Project menu and browse to select `<variation name>_sdi.sdc` file.

To add the additional .tcl file, you must compile your design and perform post compilation timing analysis using the TimeQuest timing analyzer. On the Assignments menu, click **Use TimeQuest Timing Analyzer during compilation**, and click **OK**.

You may have to further edit your scripts if your design requires single channel or multiple channels.

Single Channel

The following section describes what you must do if your design requires a single channel using SDI triple standard transmitter and receiver instances as shown in [Figure 2-3 on page 2-11](#).

Figure 2-3. Instantiating Single Channel of SDI Instances

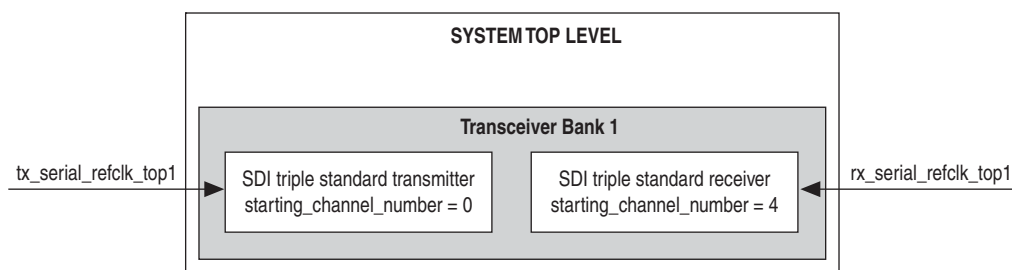

 The SDI instances must have a unique starting channel number if they are merged into a same quad or bank.

To specify the constraints, follow these steps:

1. Parameterize and generate your SDI MegaCore functions—SDI triple standard transmitter and receiver.

2. Edit the Tcl script so that the transceiver top-level reference clock matches the clock pin names that you have chosen for your design, for example `tx_serial_refclk_top1`. Locate `tx_serial_refclk_name` in the script and change to `tx_serial_refclk_top1`.

 The SDI triple standard transmitter has a transceiver top-level reference clock, `tx_serial_refclk`.

3. Execute the Tcl script to patch the generated `.sdc` script with the new clock names.

 A back-up copy of the `.sdc` script is created before the patch is made, and any edits that were previously made to the `.sdc` script are preserved.

4. Execute the Tcl script in the Quartus II software, and follow these steps:
 - a. On the Tools menu, click Tcl script.
 - b. Select the Tcl script of the instance SDI triple standard transmitter, and click Run.
5. Perform steps 2 to 4 for the SDI triple standard receiver instance.

Multiple Channels

The following section describes what you must do if your design requires multiple channels using four instances of SDI triple standard transmitter and four instances of SDI triple standard receiver. In this case, assume that you must fit all instances into Transceiver Bank 1 and 2 as shown in [Figure 2-4](#), and the SDI instances in both banks have the same video standard. You do not have to regenerate the SDI instances in Transceiver Bank 2.

Figure 2-4. Instantiating Multiple Channels of SDI Instances Sharing Same Reference Clock

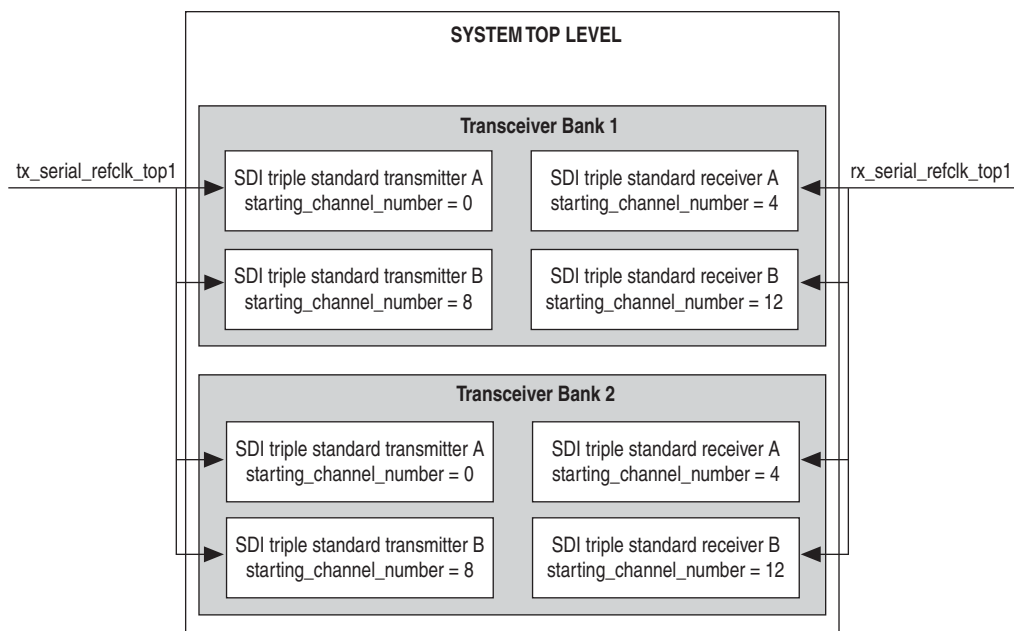

To specify the constraints, perform the following steps:

1. Parameterize and generate your SDI MegaCore functions—SDI triple standard transmitter A, SDI triple standard transmitter B, SDI triple standard receiver A, and SDI triple standard receiver B—with their unique starting channel number.
2. Edit the Tcl script so that the transceiver top-level reference clock matches the name of the clock pin connected to SDI triple standard transmitter A, for example `tx_serial_refclk_top1`. Locate `tx_serial_refclk_name` in the script and change to `tx_serial_refclk_top1`.
3. Execute the Tcl script to patch the generated `.sdc` script with the new clock names.



A back-up copy of the `.sdc` script is created before the patch is made, and any edits that were previously made to the `.sdc` script are preserved.

4. Execute the Tcl script in the Quartus II software, and perform the following steps:
 - a. On the Tools menu, click Tcl script.
 - b. Select the Tcl script of the instance SDI triple standard transmitter A, and click Run.
5. Perform steps 2 to 4 for the other three instances.

Figure 2-5. Instantiating Multiple Channels of SDI Instances Sharing Multiple Reference Clocks

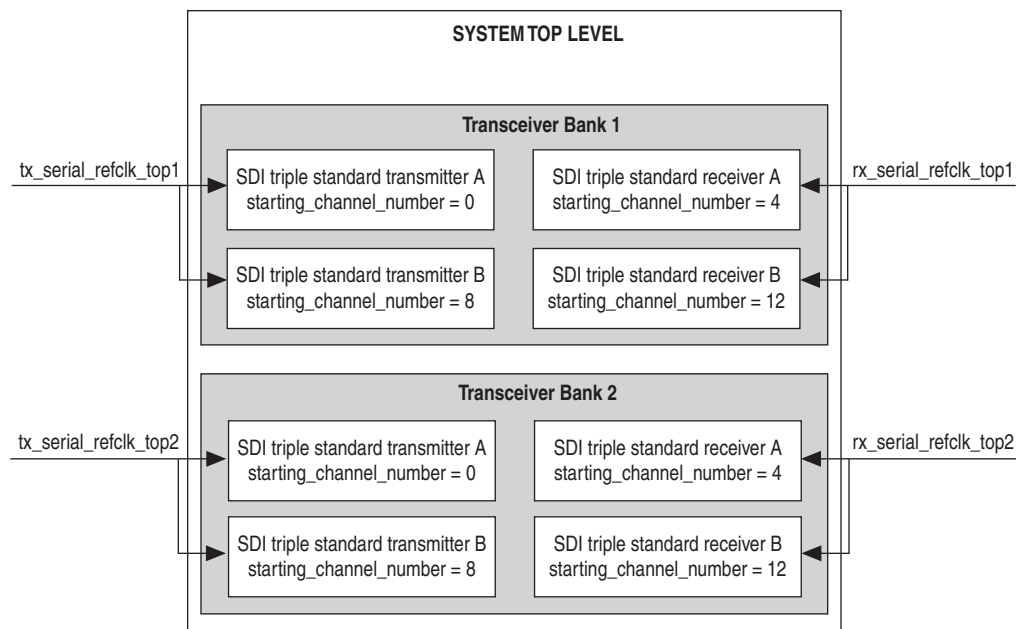

To specify constraints for multiple channels of SDI MegaCore function with multiple top-level reference clocks as shown in Figure 2-5, perform the following steps:

1. For the SDI instances in Transceiver Bank 1, perform steps 1 to 5 you would do for SDI instances sharing the same reference clock.
2. For the SDI instances in Transceiver Bank 2, duplicate an `.sdc` script for SDI triple standard transmitter A and SDI triple standard receiver A in Transceiver Bank 2.

 You are not required to duplicate `.sdc` script for SDI triple standard transmitter B and SDI triple standard receiver B in Transceiver Bank 2. Instances with same video standard can share an `.sdc` script.

3. Edit the `.sdc` script so that the reference clock name matches the name of the clock pin connected to SDI triple standard transmitter A, for example `tx_serial_refclk_top2`. Locate `tx_serial_refclk_name` in the script and change to `tx_serial_refclk_top2`.
4. Edit another `.sdc` script so that the reference clock name matches the name of the clock pin connected to SDI triple standard receiver A, for example `rx_serial_refclk_top2`. Locate `set rx_serial_refclk_name` in the script and change to `rx_serial_refclk_top2`.
5. Add these two duplicate `.sdc` scripts to your project. On the Project menu, click **Add/Remove Files in Project** and browse to select the scripts.

Compiling the Design

You can use the Quartus II software to compile your design. For instructions about performing compilation, refer to Quartus II Help.

You can find an example design using an SDI MegaCore function in the `ip/sdi/example` directory. This design is targeted at the Stratix II GX audio video development kit.

 For more information about the example design, refer to *AN 339: Serial Digital Interface Demonstration for Stratix II GX Devices*, and for information about the development kit, refer to *Audio Video Development Kit, Stratix II GX Edition*.

Programming a Device

After you have compiled the example design, you can program your targeted Altera device to verify the design in hardware.

With Altera's free OpenCore Plus evaluation feature, you can evaluate the SDI MegaCore function before you obtain a license. OpenCore Plus evaluation allows you to generate an IP functional simulation model, and produce a time-limited programming file.

 For more information about OpenCore Plus hardware evaluation using the SDI MegaCore function, refer to "OpenCore Plus Evaluation" on page 1–5, "OpenCore Plus Time-Out Behavior" on page 3–39, and *AN 320: OpenCore Plus Evaluation of Megafunctions*.

Setting Up Licensing

You must purchase a license for the MegaCore function only when you are completely satisfied with its functionality and performance and want to take your design to production.

After you purchase a license for SDI MegaCore function, you can request a license file from the Altera website at www.altera.com/licensing and install it on your computer. When you request a license file, Altera emails you a **license.dat** file. If you do not have Internet access, contact your local Altera representative.

The SDI MegaCore function implements a receiver, transmitter, or full-duplex interface. The SDI MegaCore function can handle SD, HD, and/or 3G SDIs.

The SDI MegaCore function consists of the following elements:

- Protocol blocks
 - SDI receiver
 - SDI transmitter
- A transceiver
- A transceiver controller

In the MegaWizard Plug-In Manager, you can specify either protocol or transceiver blocks or both for your design. For example, if you have multiple protocol blocks in a design, you can multiplex them into one transceiver. The transceiver can be either a soft-logic implementation or a GX transceiver.

Block Description

Figure 3-1 shows the SDI MegaCore function block diagram.

Figure 3-1. SDI MegaCore Function Block Diagram

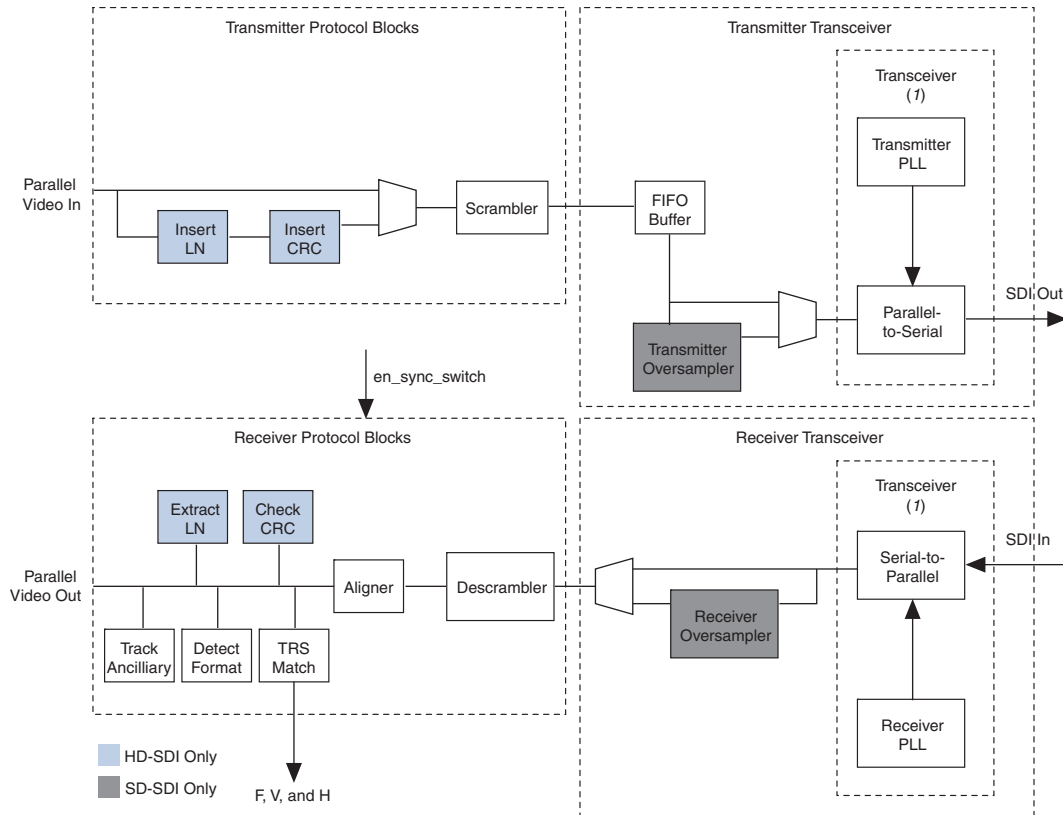

Note to Figure 3-1:

(1) For SD-SDI designs only, you can have a soft-logic implementation of the transceiver.

Transmitter

The transmitter contains the following elements:

- SD/HD-SDI transmitter scrambler
- HD-SDI transmitter data formatter, which includes a CRC and LN insertion
- Transceiver, plus control, and interface logic with multirate (dual or triple standard) SD/HD-SDI transmitter operation
- Transmitter clock multiplexer (optional)

The transmitter performs the following functions:

- HD-SDI LN insertion
- HD-SDI CRC generation and insertion
- Scrambling and NRZI coding

- Internal switching between two reference clock signals in the transmitter block. This feature is optional and only available for Arria II GZ, Stratix IV GX, and HardCopy IV devices.

Figure 3–2 shows the top-level block diagram for the SDI transmitter.

Figure 3–2. SDI Transmitter Block Diagram

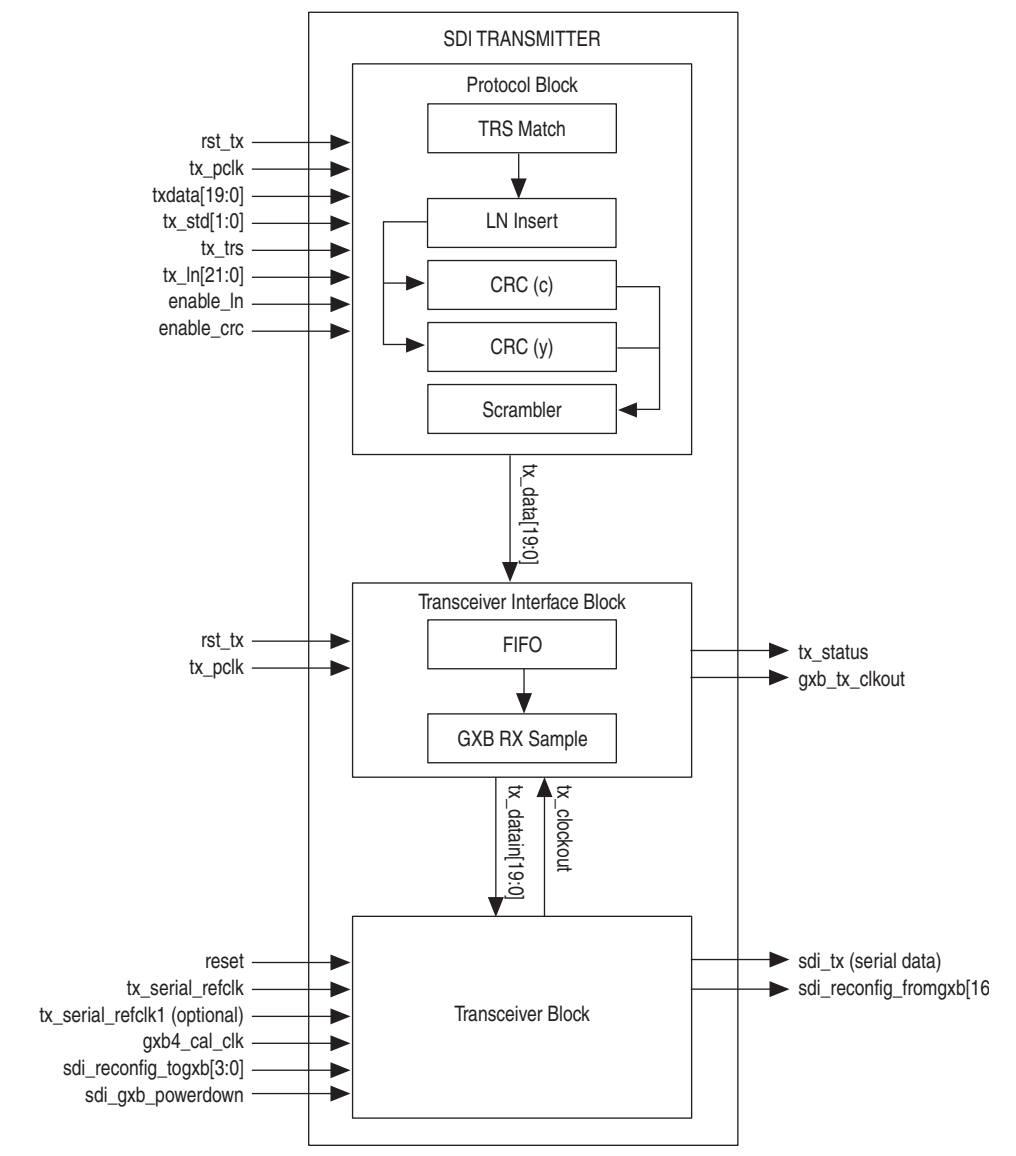

For HD-SDI, the transmitter accepts 20-bit parallel video data; for SD-SDI, 10-bit parallel data. For txdata bus definition, refer to [Table 3–16 on page 3–41](#).

Table 3-1 lists the bit allocation for txdata.

Table 3-1. Bit Allocation for txdata for Supported Video Standards

txdata	SD-SDI	HD-SDI	3G-SDI Level A	3G-SDI Level B
[19:10]	Unused	Y	Y	Cb, Y, Cr, Y multiplex (link A)
[9:0]	Cb, Y, Cr, Y multiplex	C	C	Cb, Y, Cr, Y multiplex (link B)

For HD-SDI operation, the current video line number is inserted at the appropriate point in each line. A CRC is also calculated and inserted for the luma and chroma channels.

The parallel video data is scrambled and NRZI encoded according to the SDI specification.

The transceiver converts the encoded parallel data into the high-speed serial output (parallel-to-serial conversion).

HD-SDI LN Insertion

SMPTE292M section 5.4 defines the format of two words that are included in each HD-SDI video line to indicate the current line number. The HD-SDI LN insertion module takes the lower 11-bit tx_1n, and formats and inserts it as two words in the output data. The HD-SDI LN insertion module accepts the current line number as an input.



For more information about the line insertion for other video standards, refer to the description for tx_1n signal in [Table 3-16 on page 3-41](#).

The LN words (LN0 and LN1) overwrite the two words that follow the “XYZ” word of the EAV TRS sequence. The same value is included in the luma and chroma channels.

For correct LN insertion, you must assert the tx_trs signal must be asserted for the first word of both EAV and SAV TRSs (refer to [Figure 3-31 on page 3-47](#) and [Figure 3-32 on page 3-48](#)).



If the system does not know the line number, you can implement logic to detect the output video format and then determine the current line. This function is outside the scope of this SDI MegaCore function.

HD-SDI CRC Generation and Insertion

SMPTE292M section 5.5 defines a CRC that is included in the chroma and luma channels for each HD-SDI video line. The HD-SDI CRC module generates, formats, and inserts the required CRC in the output data.

The HD-SDI CRC module identifies the words that you must include in the CRC calculation, and also determines where you must insert the words in the output data. The formatted CRC data words (YCR0 and YCR1 for the luma channel, CCR0 and CCR1 for the chroma channel) overwrite the two words that follow the line number words after the EAV. A separate calculation is provided for the luma and chroma channels.

The CRC is calculated for all words in the active digital line, starting with the first active word line and finishing with the final word of the line number (LN1). The initial value of the CRC is set to zero, then the polynomial generator equation $CRC(X) = X^{18} + X^5 + X^4 + 1$ is applied.

The HD-SDI CRC module implements the CRC calculation by iteratively applying the polynomial generator equation to each bit of the output data, processing the LSB first.

For correct CRC generation and insertion, the `tx_trs` signal must be asserted for the first word of both EAV and SAV TRS (refer to [Figure 3-31 on page 3-47](#) and [Figure 3-32 on page 3-48](#)).

Scrambling and NRZI Coding

SMPTE292M section 5 and *SMPTE292M* section 7 define a common channel coding that is used for both SDI and HD-SDI. This channel coding consists of a scrambling function ($G_1(X) = X^9 + X^4 + 1$) followed by NRZI encoding ($G_2(X) = X + 1$). The scrambling module implements this channel coding. You can configure the module to process either 10-bit or 20-bit parallel data.

The scrambling module implements the channel coding by iteratively applying the scrambling and NRZI encoding algorithm to each bit of the output data, processing the LSB first. Figure C.1 of *SMPTE259M* shows how the algorithm is implemented.

Transceiver Clock

[Figure 3-3](#) shows the clocking scheme for the transmitter.

The `tx_serial_refclk1` is an optional port that is enabled when you turn on the **Enable TX PLL select for 1/1.000 and 1/1.001 data rate reconfiguration** in the SDI parameter editor.

Figure 3-3. Transmitter Clocking Scheme

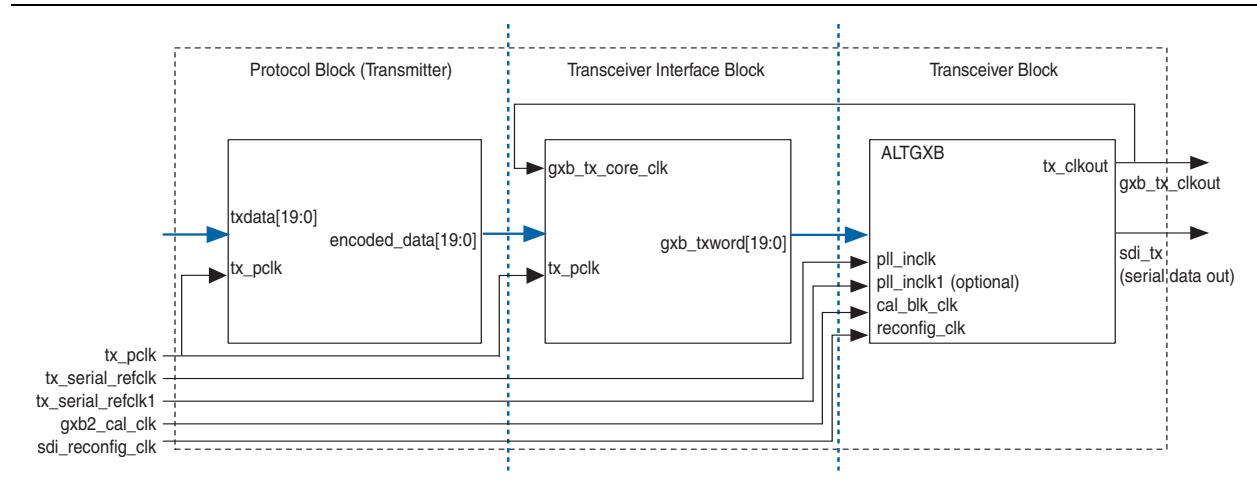

Receiver

The receiver contains the following elements:

- Transceiver, plus control, and interface logic with multirate (dual or triple standard) SD/HD-SDI receiver operation
- SD/HD-SDI receiver descrambler and word aligner
- HD-SDI receiver CRC and LN extractor
- Receiver framing, with extraction of video timing signals
- Identification and tracking of ancillary data

The SDI receiver consists of the following functions:

- NRZI decoding and descrambling
- Word alignment
- Video timing flags extraction
- RP168 switching compliance
- HD-SDI LN extraction
- HD-SDI CRC
- Accessing transceiver

Figure 3-4 shows the top-level block diagram for the SDI receiver.

Figure 3-4. SDI Receiver Block Diagram

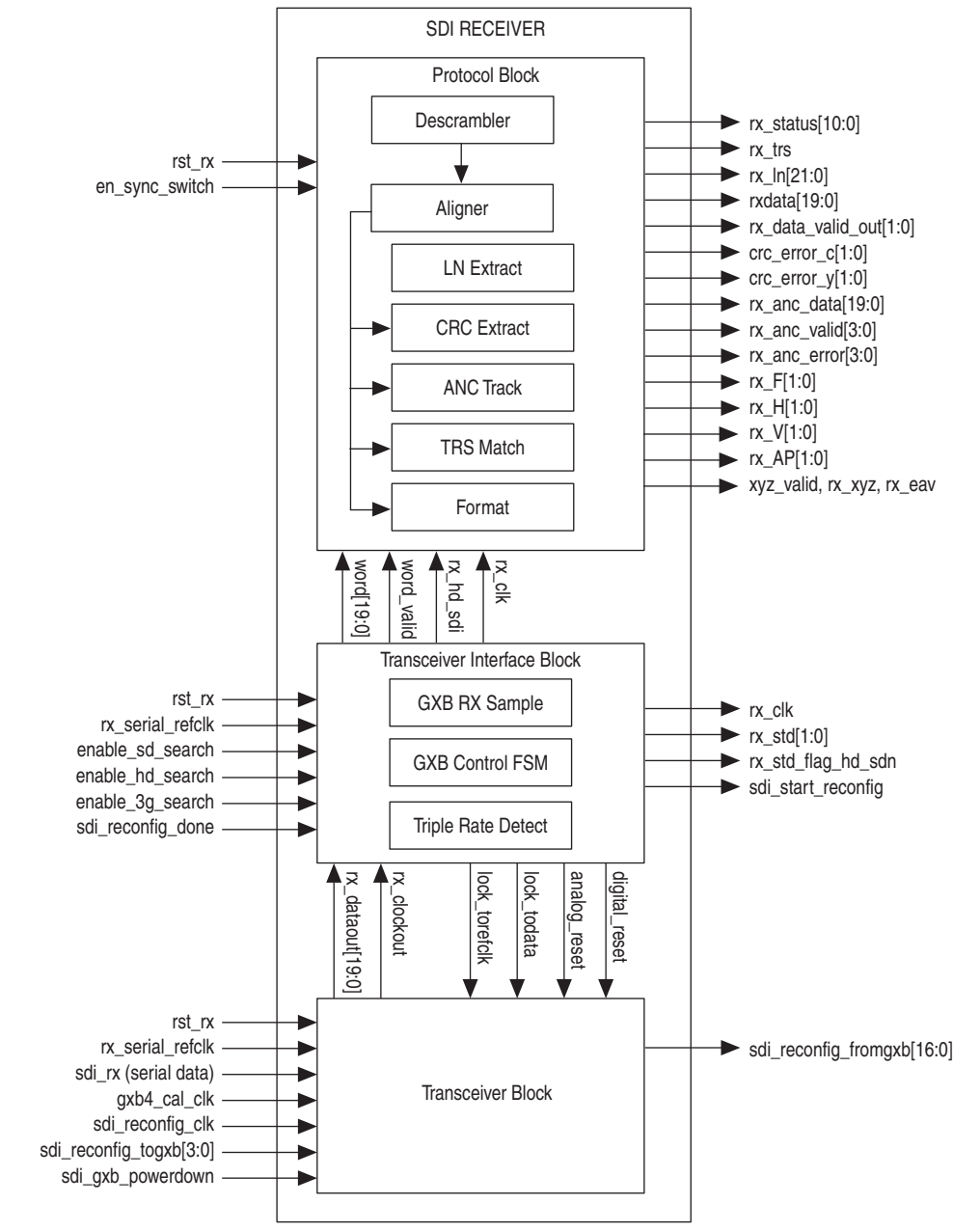

The received data is NRZI decoded and descrambled and then presented as a word-aligned parallel output—20 bit for HD-SDI; 10 bit for SD-SDI (refer to [Table 3-16 on page 3-41](#) for `rxdata` bus definition).

Table 3–2 lists the bit allocation for rxdata.

Table 3–2. Bit Allocation for rxdata for Supported Video Standards

rxdata	SD-SDI	HD-SDI	3G-SDI Level A	3G-SDI Level B
[19:10]	Unused	Y	Y	Cb, Y, Cr, Y multiplex (link A)
[9:0]	Cb, Y, Cr, Y multiplex	C	C	Cb, Y, Cr, Y multiplex (link B)

The receiver interface extracts and tracks the F, V, and H timing signals in the received data. Active picture and ancillary data words are also identified for your use.

For HD-SDI, the received CRC is checked for the luma and chroma channels. The LN is also extracted and provided as an output from the design.

NRZI Decoding and Descrambling

The descrambler module provides the channel decoding function that is common to both SDI and HD-SDI. It implements the NRZI decoding followed by the required descrambling. The algorithm indicated by SMPTE259M figure C.1 is iteratively applied to the receiver data, with the LSB processed first.

Word Alignment

The aligner word aligns the descrambled receiver data such that the bit order of the output data is the same as that of the original video data.

The EAV and SAV sequences determine the correct word alignment. Table 3–3 lists the pattern for each standard.

Table 3–3. EAV and SAV Sequences

Video Standard	EAV and SAV Sequences
SDI	3FF 000 000
HD-SDI	3FF 3FF 000 000 000 000
3G-SDI Level A	3FF 3FF 000 000 000 000
3G-SDI Level B	3FF 3FF 3FF 3FF 000 000 000 000 000 000 000 000

The aligner matches the selected pattern in the descrambled receiver data. If the pattern is detected at any of the possible word alignments, then a flag is raised and the matched alignment is indicated. This process is applied continuously to the receiver data.

The second stage of the aligner determines the correct word alignment for the data. It looks for three consecutive TRSs with the same alignment, and then stores that alignment. If two consecutive TRSs are subsequently detected with a different alignment, then this new alignment is stored.

The final stage of the aligner applies a barrel shift function to the received data to generate the correctly aligned parallel word output. For this SDI MegaCore function, the barrel shifter allows the design to instantly switch from one alignment to another.

Video Timing Flags Extraction

The TRS match module extracts the F, V, and H video timing flags from the received data. You can use these flags for receiver format detection, or in the implementation of a flywheel function.

The TRS match module also identifies the line number and CRC words for HD-SDI.

RP168 Switching Compliance

To meet the RP168 requirements, the transceiver must be able to recover by the end of the switching line. Table 3-4 lists the supported video switching type.

 For more information about the switching line and time for different video formats, refer to *RP168*.

Table 3-4. Supported Video Switching Type

Standard/ Data Rate	Format	RP168 Support	Switching Source
Fixed	Switch (same format)	Yes	HD-1080i30 to HD-1080i30
Fixed	Switch	No	HD-1080 to HD-720
Switch	Fixed	No	HD-1080 to SD-525
Switch	Switch	No	HD-1080 to SD-525

Figure 3-5 and Figure 3-6 show the behaviors of the aligner and format blocks during the RP168 switching.

The aligner block immediately aligns to the next TRS timing based on the user input `en_sync_switch` signal.

Figure 3-5. Aligner Block Behavior

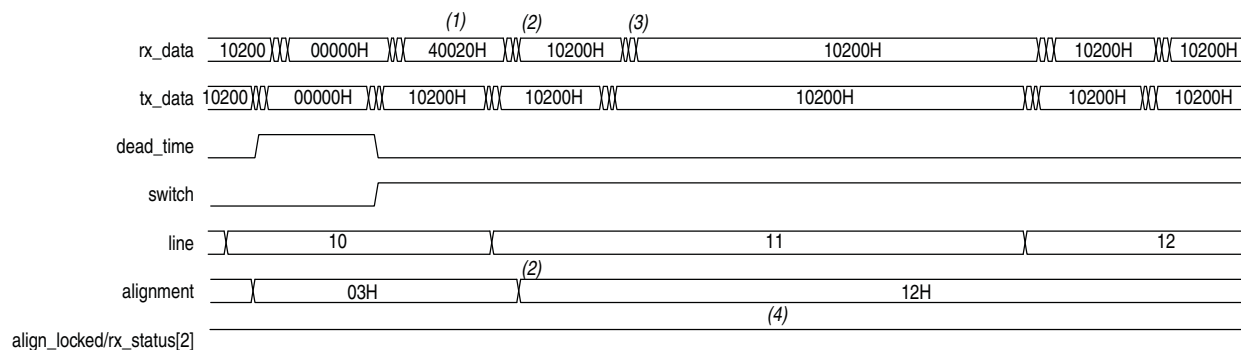

Notes to Figure 3-5:

- (1) Mismatch in alignment.
- (2) New alignment on the next TRS.
- (3) Data aligned to new alignment.
- (4) Zero interrupt.

The format block latches the user input `en_sync_switch` signal for three lines to realign to a new TRS alignment immediately. During switching, you see zero interrupt at downstream. The `trs_locked` and `frame_locked` signals never get deasserted during sync switch.

Figure 3-6. Format Block Behavior

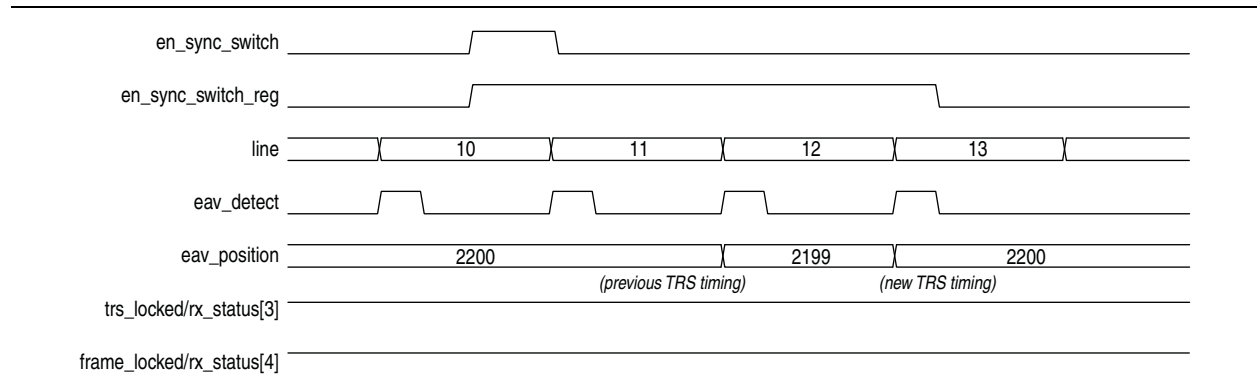

HD-SDI LN Extraction

The HD-SDI LN extraction module extracts and formats the LN words defined by SMPTE292M section 5.4 from the HD-SDI chroma channel. The design provides the LN as an output.

HD-SDI CRC Checking

The CRC module checks the CRC defined by SMPTE292M section 5.5 for the HD-SDI luma and chroma channels.



This module is common to the receiver and the transmitter.

The check is implemented by recalculating the CRCs for each received video line and then checking the results against the CRC data received. If the results differ, an error flag is asserted. There are separate error flags for the luma and chroma channels. The flag is held asserted until the next check is performed.

Accessing Transceiver

The Quartus II software enables you to access the transceiver through the unencrypted ALTGX wrapper file. You can access the ALTGX wrapper files for Arria II GX, Arria V, Cyclone IV GX, Stratix II GX, and Stratix IV GX configurations.

You can use one of the two following ways to access the ALTGX wrapper files:

- Edit the ALTGX wrapper file, using legal range provided in the respective device handbooks.
- Use analog control through the ALTGX_RECONFIG megafunction.



Do not reinitialize the customized ALTGX wrapper file using the MegaWizard Plug-In Manager so that you do not lose the default content of the wrapper file after regeneration.

Editing the ALTGX Wrapper File

If you want to change the settings of the parameters, edit the legal ranges in the ALTGX wrapper file.

For example, if you want to change the voltage output differential control setting from 4 to 7, change the following line in the wrapper file:

```
alt4gxb_component.vod_ctrl_setting = 4
```

to this line:

```
alt4gxb_component.vod_ctrl_setting = 7
```



To know the exact legal ranges for a specific Altera device, refer to the respective device handbooks.

Using Analog Control

If you want the flexibility to access and control the ALTGX settings, use the ALTGX_RECONFIG megafunction to enable analog reconfiguration. You can use the analog control to edit the default settings of the following transceiver parameters:

- Voltage output differential
- Pre-emphasis control pre-tap
- Pre-emphasis control 1st post-tap
- Pre-emphasis control 2nd post-tap
- Equalizer DC gain
- Equalized DC control

The ALTGX_RECONFIG megafunction interfaces with the ALTGX using `reconfig_togxb[3:0]` and `reconfig_fromgxb[16:0]` ports for a single channel.

To enable the analog control and channel reconfiguration during run time, use the `reconfig_mode_sel` signal.



For more information about how to use the analog control with the ALTGX_RECONFIG megafunction, refer to the *ALTGX_RECONFIG Megafunction User Guide* in the respective device handbooks.

Transceiver Clock

Figure 3-7 shows the general clocking scheme for the receiver.

Figure 3-7. Receiver Clocking Scheme

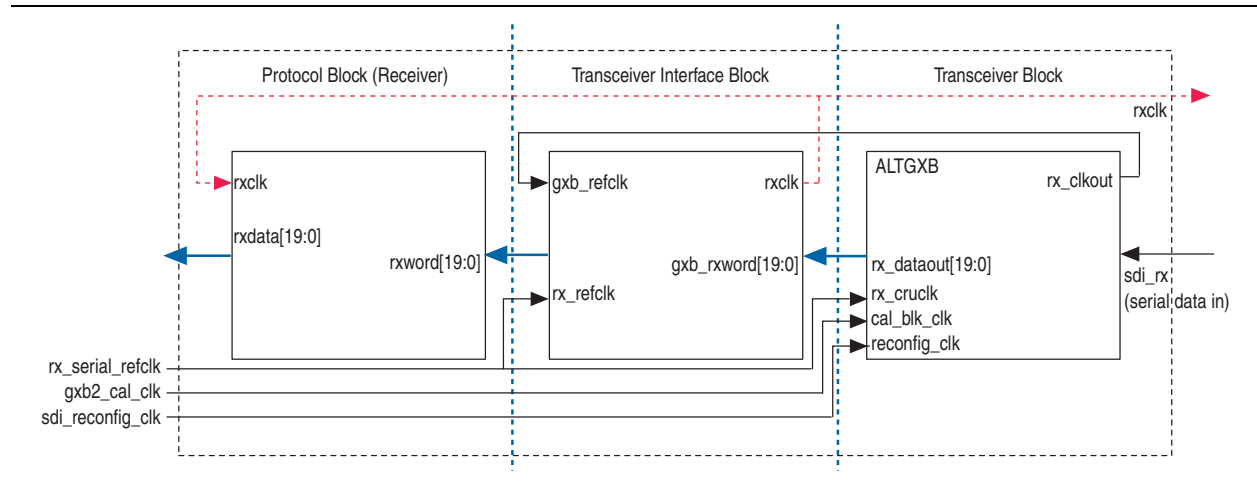

Transceiver—Soft-Logic Implementation

The soft-logic implementation differs for the transmitter and the receiver.

Transmitter

For the transmitter, in the soft-logic transceiver a 10-bit parallel word is converted into a serial data output format. A 10-bit shift register loaded at the word rate from the encoder and unloaded at the bit rate of the LVDS output buffer is implemented for that function. A PLL that multiplies a 27-MHz reference clock by ten provides the bit-rate clock and enables jitter-controlled SDI transmit serialization.

Transmitter Clocks

The serializer requires a 270-MHz clock, which you can generate from an external source (`tx_sd_refclk_270`).

The 27-MHz parallel video clock (`tx_pclk`) samples and processes the parallel video input.

Transmitter Clock Multiplexer Option

This is a new feature introduced in version 11.1. The transmitter block has the option of receiving an additional reference clock to allow dynamic switching between the 1/1000 and 1/1.001 data rates. This feature is available in Arria II, Stratix IV, and HardCopy IV devices.

By default, you can use the `tx_serial_refclk` for any normal SDI operations and the `tx_serial_refclk1` as an additional clock input parameter. You can then switch to the clock source selected by using the transceiver dynamic reconfiguration.

Receiver

For the receiver, in the soft-logic transceiver the serial data stream from the LVDS input buffer is sampled using four different clocks phase-shifted by 90° from each other. Two out of these four clocks are created from an on-chip PLL. The two remaining clocks are created by inversion of the PLL clock outputs.

Samples are then all converted to the same clock domain and deserialized into a 10-bit parallel word. The serial clock that samples the bit stream must be 337.5 MHz, which is 5/4 of the incoming bit (270-bit rate \times 5/4 \times 4 sample per clock = 1,350 Mbps)

The parallel clock that extracts data from the deserializer is running at 135 MHz.

To achieve timing, you must correctly constrain your design, refer to “Constraints” on page A-1.

Receiver Clocks

The deserializer requires three clocks (refer to Table 3-15 on page 3-41), which you can generate from an external source.

Transceiver—Stratix GX Devices

The Stratix GX transceiver deserializes the high-speed serial input. For HD-SDI, the clock data recovery (CDR) function performs the deserialization and locks the receiver PLL to the receiver data. For SD-SDI, the transceiver provides a fixed frequency oversample of the serial data with the receiver PLL constantly locked to a reference clock, which allows the transceiver to support the 270-Mbps data rate.

The transceiver can process either SD-SDI or HD-SDI data. The data rate can be automatically detected so that the interface can handle both SD-SDI and HD-SDI without the need for device reconfiguration.

In Stratix GX devices, the transmitters in a quad share a common reference clock, which prevents them from operating independently.

Receivers in a quad share a common training clock, but have independent receiver PLLs. Because the same training clock is used for SD-SDI and HD-SDI, receivers can accommodate the different standards within a single quad.

Transmitter Clocks

The transmitter requires two clocks: a parallel video clock (`tx_pclk`) and a transmitter reference clock (`tx_serial_refclk`).

The parallel video clock samples and processes the parallel video input. For SD-SDI, it is 27 MHz; for HD-SDI, it is 74.25 or 74.175 MHz.

The transceiver uses the transmitter reference clock to generate the high-speed serial output. The transceiver is configured for 20-bit operation, so the reference clock is 1/20th of the serial data rate.

 For SD-SDI, because of the oversampling implementation, the serial data rate is five times the SDI bit rate (for example, 1,350 Mbps).

For HD-SDI operation, `pclk` can drive the transmitter reference clock.

For SD-SDI operation, you can derive the transmitter reference clock from `pc1k` by using one of the Stratix GX PLLs. The PLL can multiply the 27-MHz `pc1k` signal by 5/2.

For dual standard operation, use an external multiplexer to select between the SD-SDI and HD-SDI reference clock.

The Stratix GX architecture allows each group of four transmitters (a transceiver quad) to have a separate transmitter reference clock.

Table 3-5 lists frequencies of the transmitter clock, `tx_serial_refclk`, for Stratix GX devices.

Table 3-5. Transmitter Clock Frequency—Stratix GX Devices

Video Standard ⁽¹⁾	Clock Frequency (MHz)
SD-SDI	67.5
HD-SDI (including dual link)	74.175/74.25 ⁽²⁾
HD-SDI with two times oversample	148.35/148.5 ⁽²⁾
Dual standard	67.5/74.175/74.25 ⁽²⁾

Notes to Table 3-5:

- (1) Stratix GX devices do not support 3G and triple standard modes.
- (2) The `tx_serial_refclk` signal must be externally multiplexed.

Figure 3-8 shows the transmitter clocks for different video standards.

Figure 3-8. Transmitter Clocks—Stratix GX Devices

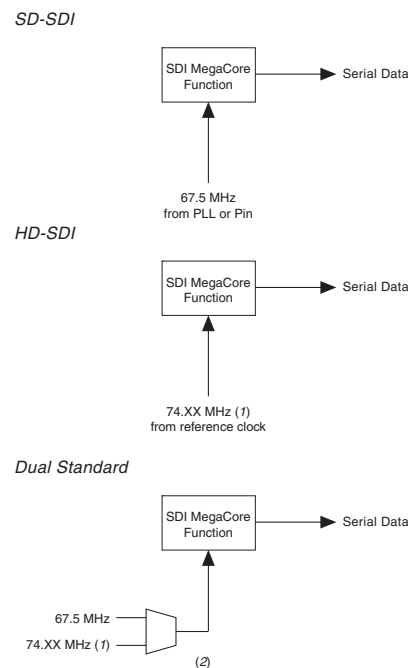

Notes to Figure 3-8:

- (1) This frequency can be either 74.175 or 74.25 MHz, to support 1.4835 or 1.485 Gbps HD-SDI respectively.
- (2) The multiplexer must not be in the device.

Receiver Clocks

The transceiver requires a receiver reference clock, `rx_serial_refclk`. This clock trains the receiver PLL in the transceiver.

For HD-SDI operation, the clock must be nominally 1/20th of the serial data rate. The clock do not have to operate at the data rate, because it is only used for the training of the receiver PLL.

For SD-SDI operation, the clock must be nominally 1/4th of the serial data rate (for example, 67.5 MHz). The clock do not have to be frequency-locked to the data.

For dual standard operation, the receiver reference clock must be 67.5 MHz, which allows the transceiver to sample the data for SD-SDI at the correct frequency. For HD-SDI, the receiver PLL trains with the 67.5-MHz reference, and then tracks to the actual incoming data rate.

All receiver interfaces can share a common receiver reference clock.

Table 3-6 lists the frequencies of the receiver clock, `rx_serial_refclk`, for Stratix GX devices.

Table 3-6. Receiver Clock Frequency—Stratix GX Devices

Video Standard ⁽¹⁾	Clock Frequency (MHz)
SD-SDI	67.5
HD-SDI (including dual link)	74.175/74.25 ⁽²⁾
Dual standard	67.5

Notes to Table 3-6:

- (1) Stratix GX devices do not support 3G-SDI and triple standard modes.
- (2) The `rx_serial_refclk` signal must be externally multiplexed.

Figure 3-9 shows the receiver clocks for different video standards.

Figure 3-9. Receiver Clocks

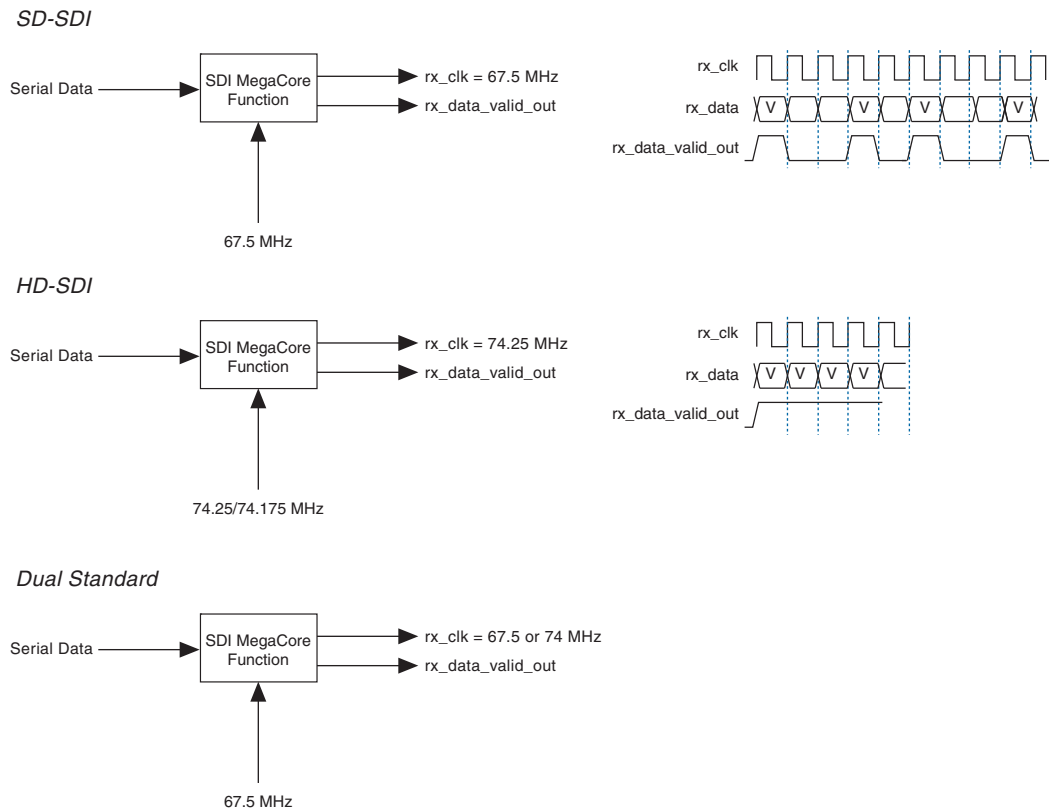

Transmitter Transceiver Interface

Altera provides a transceiver interface, which interfaces the transceiver to the SDI function. The transceiver interface implements the following functions:

- Transmitter Retiming
- HD-SDI Two-Times Oversampling
- SD-SDI Transmitter Oversampling

 When using the two-times oversampling transmitters in Stratix GX devices, you cannot have HD-SDI receivers in the same quad. The quad requires the same frequency reference clocks for both the receivers and transmitters within a quad. HD-SDI receivers and two-times oversampling transmitters have different frequency reference clocks (refer to [Table 3-5](#) and [Table 3-6](#) on [page 3-15](#)).

Transmitter Retiming

The txdata parallel data input to the transceiver must be synchronous and phase aligned to the tx_coreclk transceiver clock input. SD-SDI (and optionally HD-SDI) requires a retiming function, because of the oversampling logic. The transmitter uses a small 16×20 FIFO buffer for the retiming.

For HD-SDI, the FIFO buffer realigns the parallel video input to the transceiver `tx_coreclk` clock. It is written on every `tx_pclk` clock, and read on every `tx_coreclk`.

For SD-SDI, the FIFO buffer also provides the rate conversion required by the transmitter oversampling logic. It is written on every other `tx_pclk`, using the SD-SDI data width conversion logic. It is read on every fifth `tx_coreclk`. This operation ensures that the transmitter oversampling logic is provided with a word of parallel video data on every fifth clock.

HD-SDI Two-Times Oversampling

This mode performs two-times oversampling and runs the transceiver at double rate, which gives better output jitter performance. This mode requires a higher rate reference clock, refer to [Table 3-5 on page 3-14](#).

SD-SDI Transmitter Oversampling

SD-SDI requires a 270-Mbps serial data rate, which is achieved by transmitting a 1,350 Mbps signal with each bit repeated five times. This process ensures that the transceiver runs at a supported frequency.

Receiver Transceiver Interface

Altera provides a transceiver interface, which interfaces the transceiver to the SDI function. The transceiver interface implements the following functions:

- [SD-SDI Receiver Oversampling](#)
- [Transceiver Controller](#)



When using the two-times oversampling transmitters in Stratix GX devices, you cannot have HD-SDI receivers in the same quad. The quad requires the same frequency reference clocks for both the receivers and transmitters within a quad. HD-SDI receivers and two-times oversampling transmitters have different frequency reference clocks (refer to [Table 3-5 on page 3-14](#) and [Table 3-6 on page 3-15](#)).

SD-SDI Receiver Oversampling

The Stratix GX transceiver does not support CDR for data rates less than 500 Mbps. The receiver uses fixed frequency oversampling for the reception of 270-Mbps SD-SDI. The serial data is sampled by the transceiver at 1,350 Mbps and the original 270-Mbps data is extracted by the SD-SDI receiver oversampling logic.

[Figure 3-10](#) shows an example of the receiver data timing.

Figure 3-10. Receiver Data Timing

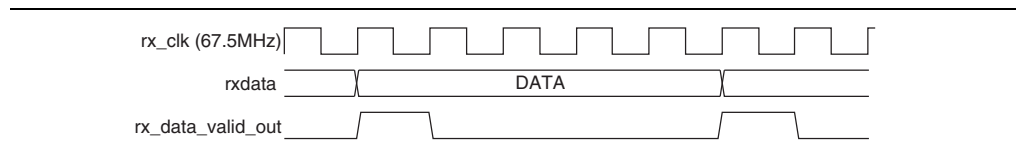

Transceiver Controller

To achieve the desired receiver functionality for the SDI, the transceiver controller controls the transceiver.

When the interface receives SD-SDI, the transceiver receiver PLL locks to the receiver reference clock.

When the interface receives HD-SDI, the transceiver receiver PLL is first trained by locking to the receiver reference clock. When the PLL is locked, it can then track the actual receiver data rate. If a period of time passes without a valid SDI signal, the PLL is retrained with the reference clock and the process is repeated.

The transceiver controller allows the transceiver to support the reception of both SD-SDI and HD-SDI data by using an algorithm that alternately searches for one rate then the other. First, it looks for an HD-SDI signal, training the PLL then letting it track the serial data rate. If a valid HD-SDI signal is not seen within 0.1 s, the receiver path is reset and the PLL is trained for SD-SDI. Conversely, if a valid SD-SDI signal is not seen within 0.1 s, the receiver path is reset and the process repeated. The transceiver controller also resets and starts searching again if the SDI receiver indicates that the signal is no longer valid.

For HD-SDI operation, if 100 consecutive bits with the same value are seen, the receiver is reset and the PLL is retrained. The maximum legal run length for HD-SDI is 59 bits.



For more information on the Stratix GX transceiver, refer to the *Stratix GX Device Handbook*.

Transceiver—Arria GX, Arria II GX, Arria V, Cyclone IV GX, Cyclone V, Stratix II GX, Stratix IV GX, and Stratix V Devices

The Arria GX, Arria II GX, Arria V, Cyclone IV GX, Stratix II GX, Stratix IV GX, or Stratix V transceiver deserializes the high-speed serial input. For HD-SDI, the CDR function performs the deserialization and locks the receiver PLL to the receiver data. For SD-SDI, the transceiver provides a fixed frequency oversample of the serial data with the receiver PLL constantly locked to a reference clock, which allows the transceiver to support the 270-Mbps data rate.

The transceiver can process either SD-SDI or HD-SDI data. The data rate can be automatically detected so that the interface can handle both SD-SDI and HD-SDI without the need for device reconfiguration.

Arria GX, Arria II GX, Arria V, Stratix II GX, Stratix IV GX, and Stratix V devices have two transmitter PLLs per quad. Each quad allows two independent transmitter rates. Receivers in a quad share a common training clock, but have independent receiver PLLs. Because the same training clock is used for SD-SDI and HD-SDI, receivers can accommodate the different standards within a single quad.

Arria II GX (including Arria II GZ) and Stratix IV GX devices also provide the option for you to enable an additional serial reference clock port. This additional clock port allows you to have two different clock rates for different data rates using a single transceiver block, with the ability to switch between the desired clock rates (for example, 148.5 MHz and 148.35 MHz).

Cyclone IV GX devices—EP4CGX30 (F484), EP4CGX50, EP4CGX75, EP4CGX110, and EP4CGX150—have eight regular transceiver channels from the upper and lower quads. There are four MPLLs and two GPLLs that you can use to clock the transceiver channels. Each receiver in EP4CGX50 and EP4CGX75 devices has a clock divider, which allows one MPLL to drive all the receiver channels. The receiver in EP4CGX110 and EP4CGX150 devices does not have a clock divider, which limits each MPLL to drive only one receiver channel to accommodate the different standards within a single quad.

You must supply two receive reference clocks (for example, 148.5 MHz and 148.35 MHz) to the SDI receiver. Implement the PPM detection function in the user logic to detect the ppm difference between the receive reference clock and the recovered clock. Based on the difference detected, you must switch between the two receive reference clocks by toggling the `rx_serial_refclk_clkswitch` signal, (Table 3-16 on page 3-41).

 For more information about the Cyclone IV GX transceiver architecture, refer to *Cyclone IV Transceivers Architecture* chapter in volume 2 of the *Cyclone IV Device Handbook*.

Cyclone V devices have up to 12 transceiver channels. The SDI support for Cyclone V transceivers requires the use of the Cyclone V Transceiver Native PHY IP Core. The native PHY is a thin IP layer with an embedded transceiver PLL.

The Cyclone V Transceiver Native PHY IP Core provides direct access to all control and status signals of the transceiver channels. Unlike other PHY IP cores, the Native PHY IP Core does not include an Avalon Memory-Mapped (Avalon-MM) interface. Instead, it exposes all signals directly as ports. The Cyclone V Transceiver Native PHY IP Core includes the Standard PCS. You can select the PCS functions and control and status port that your transceiver PHY requires. The Native Transceiver PHY does not include an embedded reset controller.

 For more information about the Cyclone V Transceiver Native PHY IP Core, refer to the *Altera Transceiver PHY IP Core User Guide*.

Transmitter Clocks

The transmitter requires two clocks: a parallel video clock (`tx_pclk`) and a transmitter reference clock (`tx_serial_refclk`).

The parallel video clock samples and processes the parallel video input. For SD-SDI, it is 27 MHz; for HD-SDI, it is 74.25 or 74.175 MHz; for 3G-SDI, it is 148.5 or 148.35 MHz.

The transceiver uses the transmitter reference clock to generate the high-speed serial output. The transceiver is configured for 20-bit operation, so the reference clock is 1/20th of the serial data rate.

 For SD-SDI, because of the oversampling implementation, the serial data rate is five times the SDI bit rate (for example, 1,350 Mbps); for the triple-standard SDI, the oversampling rate is 11.

For SD-SDI operation, the transmitter reference clock can be derived from `pclk` by using one of the transceiver PLLs. The PLL can multiply the 27-MHz `pclk` signal by 5/2.

For all other standards, use an external multiplexer to select between the alternative reference clocks.

Table 3-7 lists the frequencies of the transmitter clock, `tx_serial_refclk`, for Arria GX, Arria II GX, Arria V, Cyclone IV GX, Cyclone V, Stratix II GX, Stratix IV, and Stratix V devices.

Table 3-7. Transmitter Clock Frequency—Arria GX, Arria II GX, Arria V, Cyclone IV GX, Cyclone V, Stratix II GX, Stratix IV, and Stratix V Devices

Video Standard	Clock Frequency (MHz)
SD-SDI	67.5
HD-SDI (including dual link)	74.175/74.25 ⁽¹⁾
HD-SDI with two times oversample	148.35/148.5 ⁽¹⁾
Dual standard	67.5/74.175/74.25 ⁽¹⁾
Triple standard	148.35/148.5 ⁽¹⁾
3G-SDI	148.35/148.5 ⁽¹⁾

Note to Table 3-7:

- (1) The `tx_serial_refclk` signal must be externally multiplexed. If additional input reference clock port is enabled for serial reference clock, external multiplier is no longer required.

Figure 3-11 shows the transmitter clocks for different video standards.

Figure 3-11. Transmitter Clocks—Arria GX, Arria II GX, Arria V, Cyclone IV GX, Cyclone V, Stratix II GX, Stratix IV, and Stratix V Devices

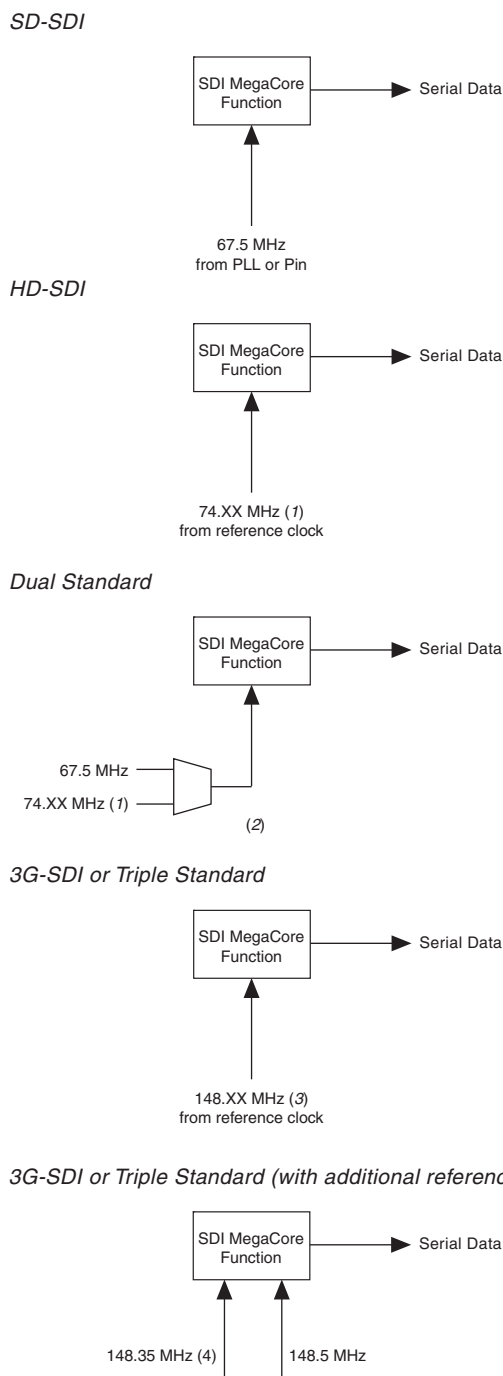

Notes to Figure 3-11:

- (1) This frequency can be either 74.175 or 74.25 MHz, to support 1.4835 or 1.485 Gbps HD-SDI respectively.
- (2) The multiplexer must not be in the device.
- (3) This frequency can be either 148.35 or 148.5 MHz, to support 2.967 or 2.970 Gbps HD-SDI respectively.
- (4) You can source both 148.5 MHz and 148.35 MHz together if the additional clock port is enabled.

Receiver Clocks

The transceiver requires a receiver reference clock, `rx_serial_refclk`. This clock trains the receiver PLL in the transceiver.

For HD-SDI operation, the clock must be nominally 1/20th of the serial data rate. The clock does not have to be frequency locked to the data, because the design only uses it for the training of the receiver PLL.

For SD-SDI operation, the clock must be nominally 1/4th of the serial data rate (for example, 67.5 MHz). The clock does not have to be frequency locked to the data.

For dual or triple standard operation, the receiver reference clock must be 148.5 MHz. In this mode, the transceiver oversamples the SD-SDI signals by a factor of 11.

All receiver interfaces can share a common receiver reference clock.

Table 3-8 shows the receiver clock `rx_serial_refclk` frequencies.

Table 3-8. Receiver Clock Frequency—Arria GX, Arria II GX, Arria V, Cyclone IV GX, Cyclone V, Stratix II GX, Stratix IV, and Stratix V Devices

Video Standard	Clock Frequency (MHz)
SD-SDI	67.5
HD-SDI (including dual link)	74.175/74.25 ⁽¹⁾
Dual or triple standard	148.35/148.5 ^{(1), (2)}
3G-SDI	148.35/148.5 ⁽¹⁾

Notes to Table 3-8:

- (1) You can use either reference clock for training.
- (2) Must be 148.5 MHz for correct SD-SDI operation.

Figure 3-12 shows the receiver clocks for different video standards.

Figure 3-12. Receiver Clocks

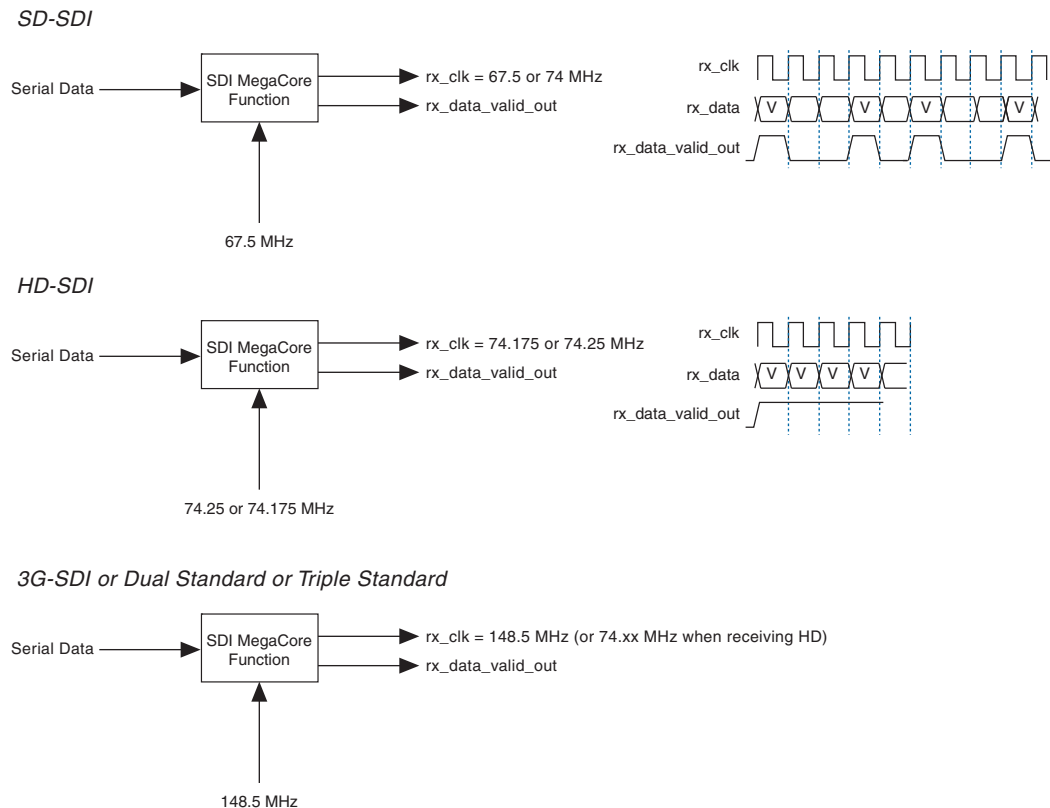

Transmitter Transceiver Interface

Altera provides a transceiver interface, which interfaces the transceiver to the SDI function. The transceiver interface implements the following functions:

- Retiming from the parallel video clock domain to the transceiver transmitter clock domain
- Optional two-times oversampling for HD
- Transmitter oversampling for SD

Transmitter Retiming

The txdata parallel data input to the transceiver must be synchronous and phase aligned to the tx_coreclk transceiver clock input. SD-SDI (and optionally HD-SDI) requires a retiming function, because of the oversampling logic. The transmitter uses a small 16 × 20 FIFO buffer for the retiming.

For HD-SDI, the FIFO buffer realigns the parallel video input to the transceiver tx_coreclk clock. It is written on every tx_pclk clock, and read on every tx_coreclk.

For SD-SDI, the FIFO buffer also provides the rate conversion required by the transmitter oversampling logic. It is written on every other `tx_pclk`, using the SD-SDI data width conversion logic. It is read on every fifth or eleventh `tx_coreclk`. This operation ensures that the transmitter oversampling logic is provided with a word of parallel video data on every fifth or eleventh clock.

HD-SDI Two-Times Oversampling

This mode performs two-times oversampling and runs the transceiver at double rate, which gives better output jitter performance. This mode requires a higher rate reference clock, refer to [Table 3-5 on page 3-14](#).

SD-SDI Transmitter Oversampling

SD-SDI requires a 270-Mbps serial data rate, which is achieved by transmitting a 1,350 Mbps signal with each bit repeated five times. This process ensures that the transceiver runs at a supported frequency. In triple standard mode, bit are transmitted at 2,970 Mbps with each bit repeated 11 times.

Receiver Transceiver Interface

Altera provides a transceiver interface, which interfaces the transceiver to the SDI function. The transceiver interface implements the following functions:

- [SD-SDI Receiver Oversampling](#)
- [Transceiver Controller](#)

SD-SDI Receiver Oversampling

Arria GX and Stratix II GX transceivers do not support CDR for data rates less than 622 Mbps. Arria II GX, Arria V, Stratix IV, and Stratix V transceivers do not support CDR for data rates less than 600 Mbps. The receiver uses fixed frequency oversampling for the reception of 270-Mbps SD-SDI. The transceiver samples the serial data at 1,350 or 2,970 Mbps and the SD-SDI receiver oversampling logic extracts the original 270 Mbps data.

[Figure 3-13](#) shows an example of the receiver data timing.

Figure 3-13. Receiver Data Timing

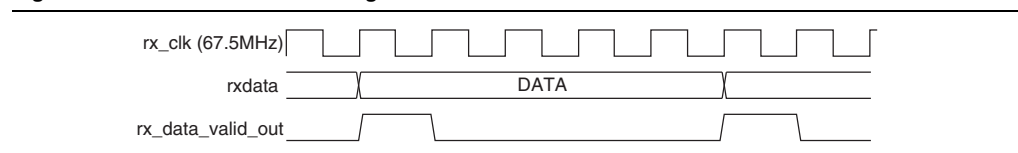

Transceiver Controller

To achieve the desired receiver functionality for the SDI, the transceiver controller controls the transceiver.

When the interface receives SD-SDI, the transceiver receiver PLL locks to the receiver reference clock.

When the interface receives HD-SDI, the transceiver receiver PLL is first trained by locking to the receiver reference clock. When the PLL is locked, it can then track the actual receiver data rate. If a period of time passes without a valid SDI signal, the PLL is retrained with the reference clock and the process is repeated.

First, the transceiver controller makes a coarse rate detection of the incoming data stream. Then, the transceiver is reprogrammed using transceiver dynamic reconfiguration (refer to “[Transceiver Dynamic Reconfiguration for Dual Standard and Triple Standard Receivers](#)” on page 3-27 and “[Transceiver Dynamic Reconfiguration with PLL Reconfiguration Mode—Cyclone IV GX](#)” on page 3-33) to the correct rate for the standard that has been detected. After the reprogramming, the transceiver attempts to lock to the incoming stream. If no valid data is seen in 0.1 s, the receiver path is reset and the rate detection is performed again.

At the start of the rate detection process, the level of the three `enable_xx` signals is sampled. The level of these signals and the knowledge of the currently programmed state of the transceiver determines if the transceiver requires programming. This process ensures that the transceiver is reprogrammed only when necessary.

Locking to the Incoming SDI Stream

The transceiver control state machine uses the presence (or absence) of TRSs on the stream to determine if SDI is being correctly received. A single, valid TRS indicates to the control state machine that the receiver is acquiring some valid SDI samples. The control state machine only deasserts this flag when it does not detect any EAV sequences within the number of consecutive lines you specified. At this point, the controller state machine resets and performs the relock algorithm, refer to [Figure 3-14](#).

Figure 3-14. Locking Algorithm

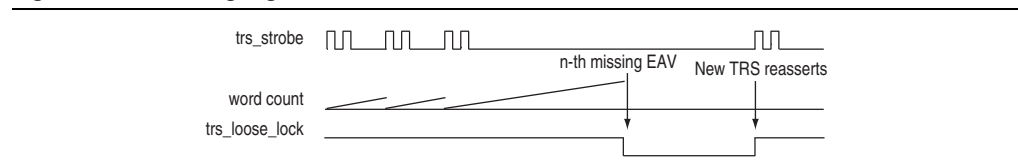

Because the aligner realigns to a new alignment if two consecutive TRSs with the same alignment are detected, this scheme allows for an SDI source switch and an alignment change without affecting the transceiver reset state machine.

The SDI MegaCore function also monitors the incoming EAV and SAV signals to ensure their spacing is consistent over a number of lines. The MegaCore function monitors by incrementing a counter on each incoming SDI word and storing the count values at which an EAV or SAV is detected. If the EAV and SAV spacing is consistent over 6 video lines, the MegaCore function indicates `trs_locked` on the `rx_status[3]` output.

An enhancement in the current SDI MegaCore function allows a number of missing EAV or SAV that you specify to be tolerated without deasserting the `trs_locked` signal.

For example, when you specify the **Tolerance to consecutive missed EAV/SAV** parameter to 2, one or two consecutive missing EAVs set a “missed” flag but do not cause the `trs_locked` signal to deassert. A good EAV in the correct position resets the “missed” flag.

The operation of this missing or misplaced TRS tolerance is shown in [Figure 3-15](#), [Figure 3-16](#), and [Figure 3-17](#).

Figure 3-15 and Figure 3-16 show how one or two consecutive missing EAVs do not cause the `trs_locked` signal to deassert.

Figure 3-15. Single Missing EAV Signal

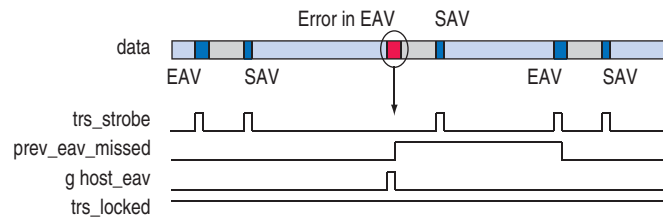

Figure 3-16. Two Consecutive Missing EAV Signal

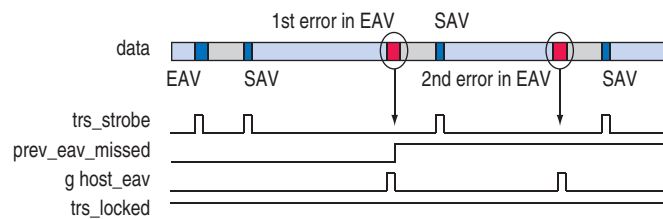
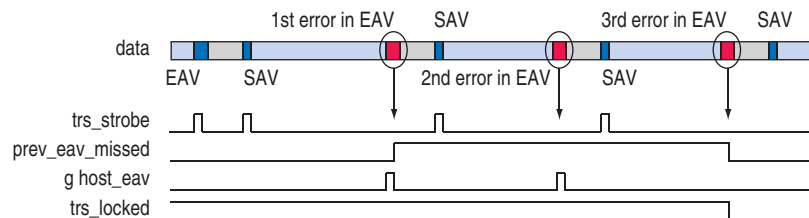

Figure 3-17 shows how three consecutive missing EAVs cause the `trs_locked` signal to deassert.

Figure 3-17. Three Consecutive Missing EAV Signal



The `frame_locked` signal detects TRS EAV, inspects the transition of field (F) and vertical (V) synchronizations, and then counts the line number. The inspecting transitions on the F and V synchronizations provide the frame timing. The line count value is stored if there is a rising or falling edge on the F and V synchronizations through the frame. The stored count values are compared over multiple frames to make sure they are stable, before the `frame_locked` signal is asserted.

The `frame_locked` signal deasserts when there are bad F or V synchronizations, or when there is a rising edge from frame to frame. The `frame_locked` signal also deasserts when the `trs_locked` signal deasserts.

When the `frame_locked` signal is zero, the frame is invalid, and the receiver is not considered to receive reliable video data.

Transceiver Dynamic Reconfiguration for Dual Standard and Triple Standard Receivers

Dual standard and triple standard SDI receivers (or receivers of duplex SDIs) require the transceiver dynamic reconfiguration feature of Arria GX, Arria II GX, Cyclone IV GX, Stratix II GX, and Stratix IV devices to perform autodetection and locking to different SDI rates.

Table 3-9 lists the transceiver dynamic reconfiguration support for Arria II GX, Cyclone IV GX, HardCopy IV GX, Stratix GX, Stratix II GX, and Stratix IV GX devices.

Table 3-9. Transceiver Dynamic Reconfiguration Support for Altera Devices ⁽¹⁾

Transceiver Dynamic Reconfiguration Support	Arria II GX, HardCopy IV GX, Stratix GX, Stratix II GX, and Stratix IV GX	Cyclone IV GX (EP4CGX50, EP4CGX75)	Cyclone IV GX (EP4CGX110, EP4CGX150) ⁽²⁾
Channel Reconfiguration	Yes	Yes	No
PLL Reconfiguration	No	Yes	Yes
Transceiver Reconfiguration	No	No	No

Note to Table 3-9:

- (1) The SDI MegaCore function versions 10.1 and later do not support MIF generation for EP4CGX30 (F484), EP4CGX50, and EP4CGX75.
- (2) The ALTGX_RECONFIG is required for offset cancellation purposes for all transceiver instances.



For more information about transceiver dynamic reconfiguration, refer to the *Arria GX Device Handbook*, *Arria II GX Device Handbook*, *Cyclone IV Device Handbook*, *Stratix II GX Device Handbook*, and *Stratix IV Device Handbook*.

Transceiver Dynamic Reconfiguration with Channel Reconfiguration Mode—Arria II GX, HardCopy IV GX, Stratix GX, Stratix II GX, and Stratix IV GX

Transceiver dynamic reconfiguration allows you to change the settings of the device transceivers (ALT2GXB or ALTGX) at any time. Transceiver dynamic reconfiguration reprograms the transceivers to support the three SDI rates.

The triple standard SDI uses 11 times oversampling for receiving SD-SDI. Hence, only Arria II GX or Stratix II GX transceiver configurations are required as the rates for 3G-SDI and SD-SDI 11 times are the same.

Table 3-10 lists the transceiver dynamic reconfiguration requirements.

Table 3-10. Transceiver Dynamic Reconfiguration Requirements

SDI Standard	Receiver	Transmitter ⁽¹⁾	Duplex ⁽¹⁾
SD-SDI	No	Yes	Yes
HD-SDI	No	Yes	Yes
3G-SDI	No	Yes	Yes
Dual link	No	Yes	Yes
Dual standard	Yes	Yes	Yes
Triple standard	Yes	Yes	Yes

Note to Table 3-10:

- (1) If the additional serial reference clock feature is enabled, the transmitters require dynamic reconfiguration to enable toggling switching between the two input clocks.

Table 3-11 lists the rates for the different SDI standards.

Table 3-11. SDI Standard Rates

SDI Standard	Data Rate	Oversampling	Transceiver Rate (MHz)	Transceiver Reference Clock (MHz)	rx_clk Rate
SD-SDI	270 Mbps	11 times	2,970	148.5	148.5
HD-SDI	1.485 Gbps	None	1,485	148.5 ⁽¹⁾	74.25 ⁽¹⁾
3G-SDI	2.970 Gbps	None	2,970	148.5 ⁽¹⁾	148.5 ⁽¹⁾

Note to Table 3-11:

- (1) Also supports the 1/1.001 rates for all supported devices, except Cyclone IV GX devices. For Cyclone IV GX devices, the transceiver reference clock must be 148.35 MHz to support the 1/1.001 rates.

To reprogram the transceivers, you must include the ALT2GXB_RECONFIG or ALTGX_RECONFIG megafunction in your design. However, to reprogram Arria II GX or Stratix IV device family, you require an ALTGX_RECONFIG megafunction. You can get this parameterization from the `example\2gx_tr\source\sdi_dprio_siv` directory in the example design. Similarly, to reprogram Cyclone IV GX device family with channel reconfiguration mode, you require a slightly different configuration of the ALTGX_RECONFIG megafunction. You can get this parameterization from the `simulation\modelsim\trsd_c4gx\channel_reconfig\testbench\pattern_gen` directory in the example simulation.



For more information about the ALT2GXB_RECONFIG megafunction, refer to the *Stratix II GX ALT2GXB_RECONFIG Megafunction User Guide*. For more information about the ALTGX_RECONFIG megafunction, refer to the *Stratix IV ALTGX_RECONFIG Megafunction User Guide*.

Transceiver Reconfiguration for Transmitter Clock Multiplexer

The transmitter reconfiguration requires its own Memory Initialization Files (.mif) that is stored in the device. The .mif contains information about the default selection of the TX PLL that is based on the `logical_tx_pll_sel` and `logical_tx_pll_sel_en` pins. These pins are available in the transceiver port when you enable the transmitter clock multiplexer feature. By toggling the values in these ports and reconfiguring the transmitter megafunction, you can internally switch the TX PLL to select different reference clock inputs. For Arria II and Stratix IV devices, these are 19-words by 16-bits files. The following are the sequence of events that occur during the SDI transmitter clock toggling:

1. SDI MegaCore function detects a change request to the serial reference clock.
2. The `ALTGX_RECONFIG` block reads the appropriate ROM, sets the `logical_tx_pll_sel` and `logical_tx_pll_sel_en` ports to the required value, and reprograms the `ALTGX` in the transmitter block.
3. When step 2 is completed, the SDI transmitter begins locking on the new serial reference clock.

 User logic is required in handling the handshaking between the SDI MegaCore function and the `ALTGX_RECONFIG` block.

 By default, the receiver reconfiguration has higher priority than the transmitter reconfiguration.

Transceiver Reconfiguration for Receiver

The ROMs store the alternative setups for the transceiver settings within the device. These setups are 28 words by 16 bits for Arria GX and Stratix II GX devices, and 38 words by 16 bits for Arria II and Stratix IV devices. The `ALT2GXB` megafunction has a serial reprogramming interface, so the `ALT2GXB_RECONFIG` block must serialize this parallel data before loading.

The following sequence of events occur during an SDI receiver rate change:

1. SDI MegaCore function detects the incoming video rate and requests reprogramming.
2. The `ALT2GXB_RECONFIG` block reads the appropriate ROM, serializes the data, and applies the serial data to the correct transceiver instance.
3. When step 2 is completed, the `ALT2GXB_RECONFIG` block indicates to the SDI that reprogramming is complete.
4. The SDI starts the process of locking to the incoming data.

 Some user logic is required to handle the handshaking between the SDI MegaCore function and the `ALT2GXB_RECONFIG` megafunction. For example, refer to the example design in the `example\s2gx_tr\source\sdi_dprio` directory.

Figure 3-19 shows a flow chart of the SDI dynamic reconfiguration process for transceiver-based devices.

Figure 3-18. Dynamic Reconfiguration Process Flow for Transceiver-based Devices

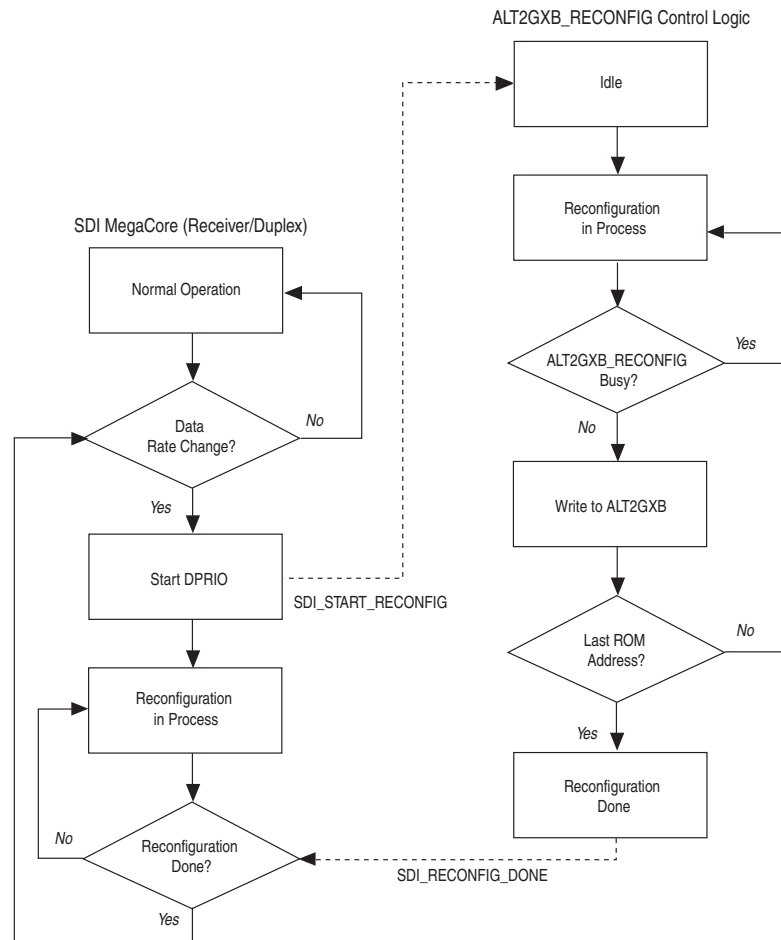

Notes to Figure 3-18:

- (1) SDI MegaCore (Receiver/Duplex) asserts `rx_analogreset` and `rx_digitalreset` signals to transceiver when the transceiver is being reconfigured.
- (2) The `rx_analogreset` signal deasserts when the transceiver is completely reconfigured, and `rx_digitalreset` signal deasserts when `rx_pll` is stable.

Figure 3-19 shows the block diagram of how the SDI MegaCore function and the ALT2GXB_RECONFIG megafunction are connected.

Figure 3-19. Transceiver Dynamic Reconfiguration for Receiver Block Diagram

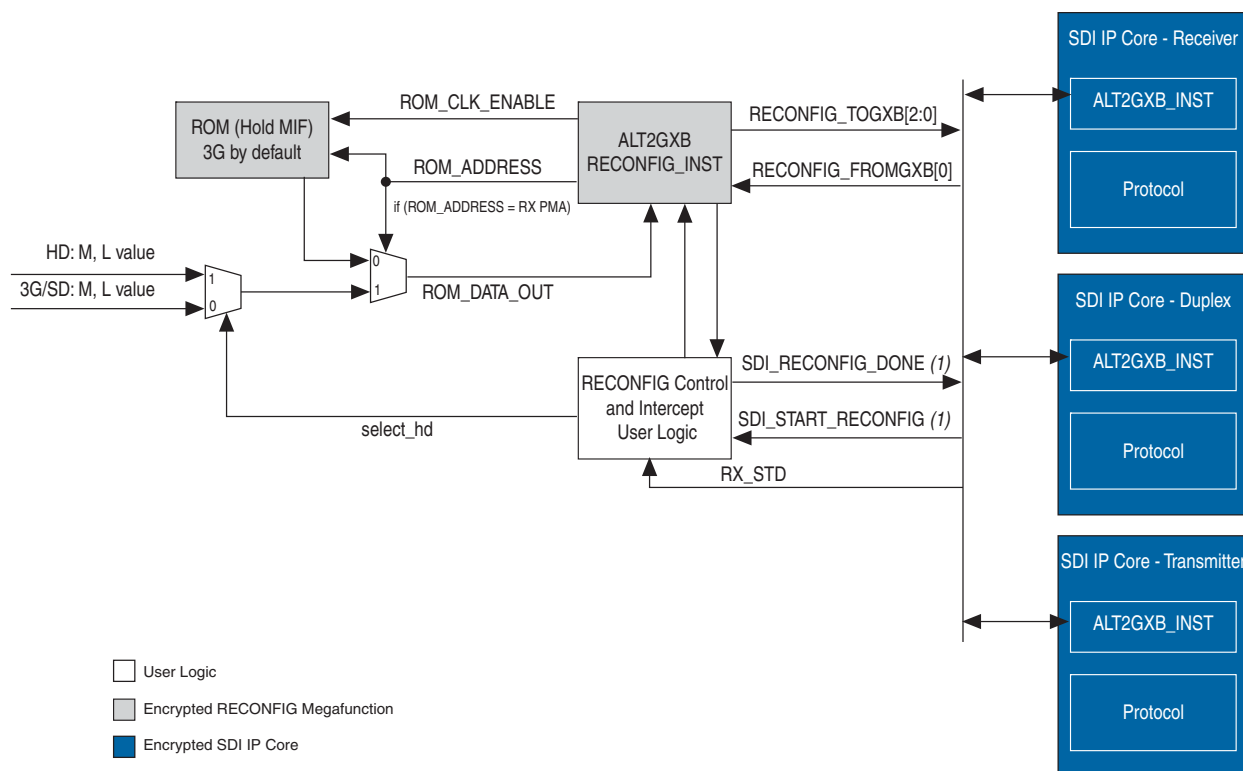

Note to Figure 3-19:

(1) The SDI_START_RECONFIG and SDI_RECONFIG_DONE signals are not connected to the SDI MegaCore transmitter.

The ALT2GXB_RECONFIG block handles the programming of the ROM contents into the transceiver megafunction. It performs data serialization and also handles protection of certain data bits in the serial stream. You can only connect this block to the reprogramming ports of the transceiver instance.

The ROM holds the transceiver setting information for the 3G-SDI video standard. As the setup for SD-SDI is similar to 3G-SDI, only two settings are required: one for SD-SDI and 3G-SDI, and one for HD-SDI.

The reconfiguration control and intercept user logic selects the correct transceiver setting and also provides the handshaking between the SDI MegaCore function and the ALT2GXB_RECONFIG block. The logic modifies the ROM read data when it reads word 23 for all devices, barring Arria II GX and Stratix IV devices. For Arria II GX and Stratix IV devices, the logic modifies the ROM read data when it reads word 29. For examples, refer to the intercept logic, `example\s2gx_tr\source\sdi_dprio\sdi_mif_intercept.v` and `example\A2gx_tr\source\sdi_dprio_siv\sdi_mif_intercept_siv.v`.

The transceiver megafunction is embedded inside the SDI MegaCore function. The reprogramming ports (`reconfig_togxb[3:0]` and `reconfig_fromgxb[<(N×16)-1>:0]`) for the transceiver megafunction are brought to the top-level interfaces of the MegaCore function. This interface only connects to the ALT2GXB_RECONFIG or ALTGX_RECONFIG block.

Figure 3-19 shows the block diagram of how the SDI MegaCore function and the ALT2GXB_RECONFIG megafunction are connected when you use the transmitter clock multiplexer feature.

Figure 3-20. Transceiver Dynamic Reconfiguration for Transmitter Clock Multiplexer Block Diagram

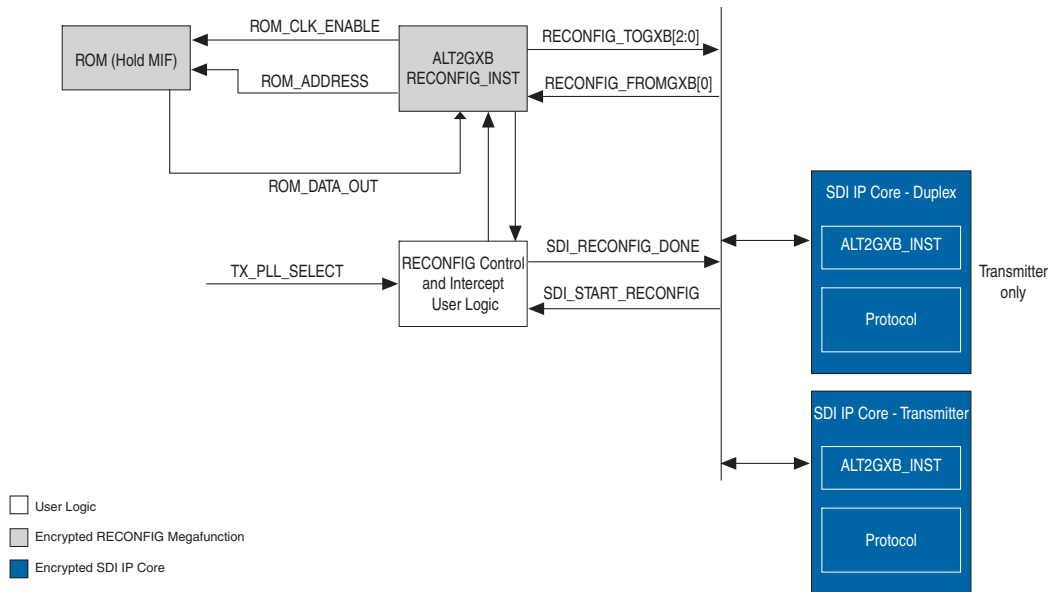

When enabling the transmitter clock multiplexer feature, the ALT2GXB_RECONFIG block handles the programming of the ROM contents to the transceiver megafunction. The ROM holds the information setting for the default reference clock selection of the TX PLL in the transmitter, as well as the values of the `logical_tx_pll_sel` and `logical_tx_pll_sel_en` pins. The reconfiguration control and intercept user logic block detects changes in the trigger port, sets the `logical_tx_pll_sel` and `logical_tx_pll_sel_en` to the corresponding value, and initiates the reprogramming of the transmitter megafunction.

ALT2GXB_RECONFIG Connections for Receiver

The `SDI_START_RECONFIG` and `SDI_RECONFIG_DONE` signals handle the handshaking between the SDI MegaCore function and the user logic. The `RX_STD` signal must select the correct transceiver setting.

 Table 3-19 on page 3-54 lists the five signals that handle transceiver dynamic reconfiguration.

Figure 3–21 shows the handshaking between the SDI MegaCore function and the user logic, and the expected output of some of the ALT2GXB_RECONFIG signals.

Figure 3–21. Handshaking Between SDI MegaCore Function and ALT2GXB_RECONFIG Signals

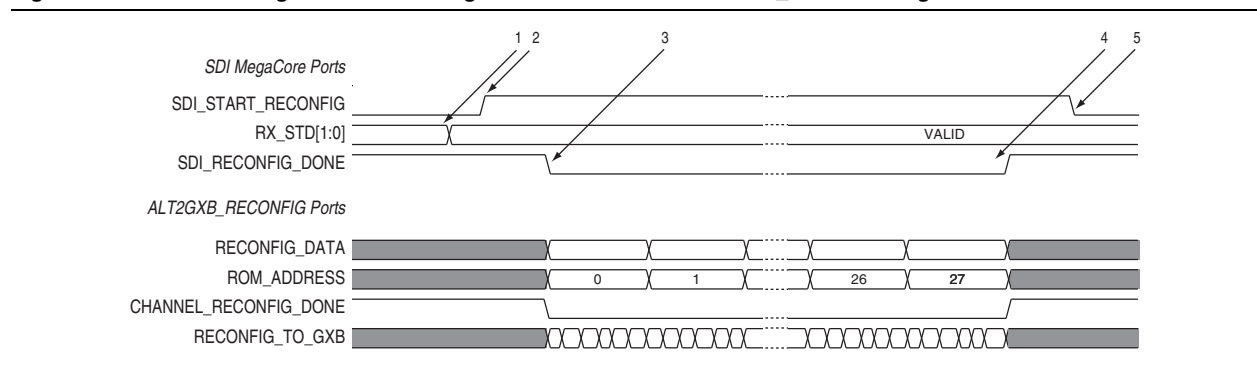

The following sequence of events occur for handshaking to the reconfiguration logic:

1. The SDI MegaCore function sets `rx_std[1:0]` to the desired video standard. This action is performed as part of the video standards detection algorithm.
2. The SDI MegaCore function asserts `SDI_START_RECONFIG` to make a reconfiguration request.
3. The user logic sets `SDI_RECONFIG_DONE` to 0, which indicates to the MegaCore function that the reconfiguration is in progress.
4. When the reconfiguration has been performed, the user logic sets the `SDI_RECONFIG_DONE` to logic 1, which indicates to the SDI MegaCore function to start locking to the incoming data.
5. The SDI MegaCore function sets the `SDI_START_RECONFIG` line to 0 to indicate that the request is completed and acknowledged.



The CRC error signal is asserted during the reconfiguration of the transceiver in the receiver. The assertion of the CRC error signal is normal during receiver reconfiguration as the receiver protocol is interrupted.

Transceiver Dynamic Reconfiguration with PLL Reconfiguration Mode—Cyclone IV GX

To implement transceiver dynamic reconfiguration for dual and triple standard SDI using Cyclone IV GX devices, you can also use PLL reconfiguration mode. To reprogram Cyclone IV GX device family with PLL reconfiguration mode, you must include the `ALTPLL_RECONFIG` megafunction in your design. You can get this parameterization from the `simulation\modelsim\trsdic4gx\pll_reconfig\testbench\pattern_gen` directory in the example simulation.

Figure 3–22 shows the block diagram of how the SDI MegaCore function and the ALTPLL_RECONFIG megafunction are connected.

Figure 3–22. Transceiver Dynamic Reconfiguration Block Diagram Using PLL Reconfiguration Mode

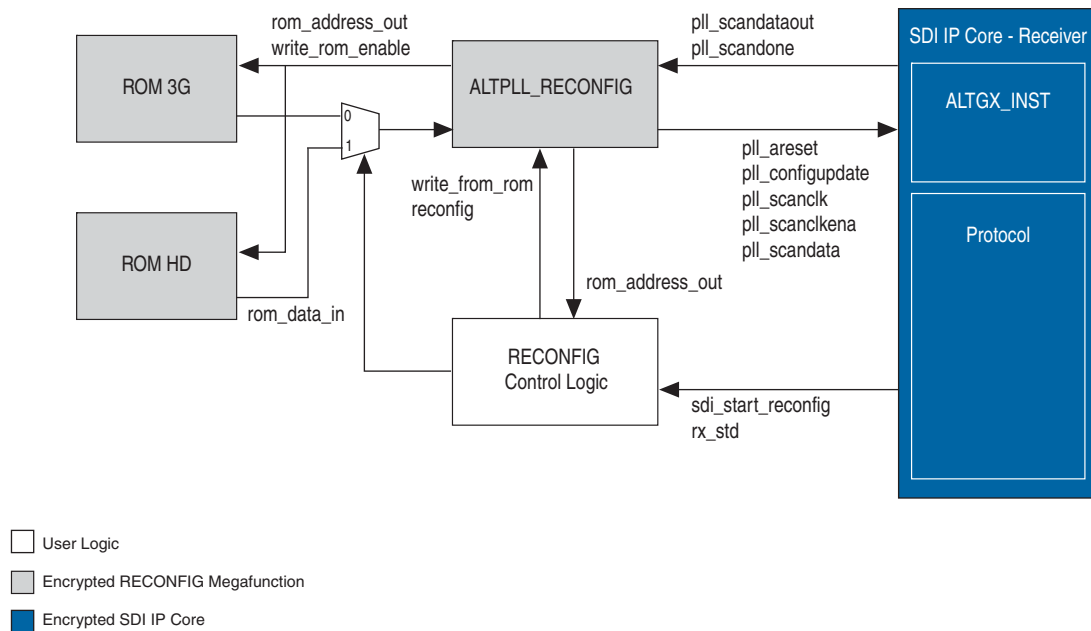

The ALTPLL_RECONFIG block handles the programming of the ROM contents into the transceiver megafunction. The ROM holds the transceiver setting information for 3G-SDI video standard. As the setup for SD-SDI is similar to 3G-SDI, only two settings are required: one for SD-SDI and 3G-SDI, and one for HD-SDI.

The reconfiguration control logic selects the correct transceiver setting and also provides the handshaking between the SDI MegaCore function and the ALTPLL_RECONFIG block. The PLL reprogramming signals for the transceiver are brought to the top-level interface of the SDI MegaCore function. This interface is only available when you select **Use PLL reconfiguration for transceiver dynamic reconfiguration** option in the SDI parameter editor. You must connect this interface only to the ALTPLL_RECONFIG block.

ALTPLL_RECONFIG Connections

Figure 3-21 shows the handshaking between the SDI MegaCore function and the reconfig control logic, and the expected output of some of the ALTPLL_RECONFIG signals.

Figure 3-23. Handshaking between SDI MegaCore Function and ALTPLL_RECONFIG Signals

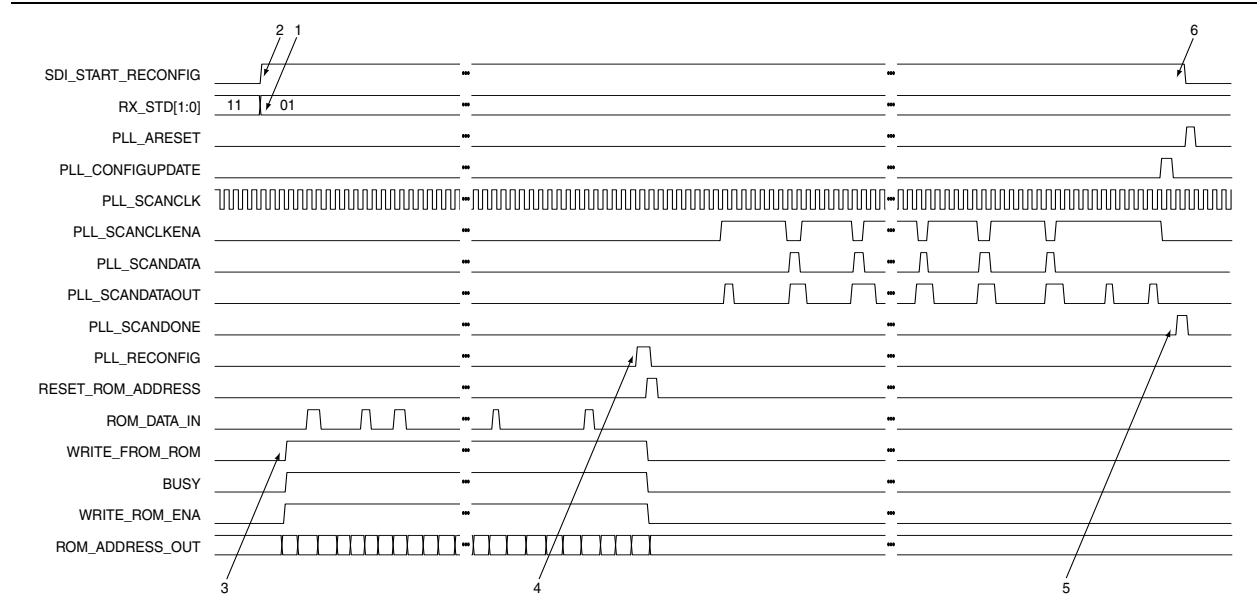

The following sequence of events occur for handshaking to the reconfiguration logic:

1. The SDI MegaCore function sets `rx_std[1:0]` to the desired video standard. This action is performed as part of the video standards detection algorithm.
2. The SDI MegaCore function asserts `SDI_START_RECONFIG` to make a reconfiguration request.
3. The reconfig control logic sets `WRITE_FROM_ROM` line to 1, and signals the ALTPLL_RECONFIG megafunction to write from the ROM.
4. The reconfig control logic asserts the `PLL_RECONFIG` line to 1, and signals the ALTPLL_RECONFIG megafunction to start the reconfiguration process.
5. When the reconfiguration has been performed, the transceiver's PLL asserts the output signal, `PLL_SCANDONE`, to the ALTPLL_RECONFIG megafunction indicating that the PLL is reconfigured, and internally indicates to the SDI MegaCore function to start locking to the incoming data.
6. The SDI MegaCore function sets the `SDI_START_RECONFIG` line to 0 to indicate that the request is completed and acknowledged.

Reset Requirement During Reconfiguration

When a receiver, placed in the same channel with a transmitter, detects a video format change, the receiver goes through a reset sequence for reconfiguration. However, as both the receiver and transmitter work independently, the IP core does not reset the transmitter during the receiver reconfiguration. If you require the transmitter to go through a reset sequence, you can reset it externally.

To reset the transmitter externally, you must instantiate a separate transmitter and receiver at the **Interface Settings** option. Then, connect the `SDI_START_RECONFIG` signal from the receiver instance to the `rst` input port in the corresponding transmitter instance, while the dynamic reconfiguration controller reconfigures the receiver, refer to [Figure 3-24](#).

Figure 3-24. Resetting Transmitter Externally During Receiver Reconfiguration

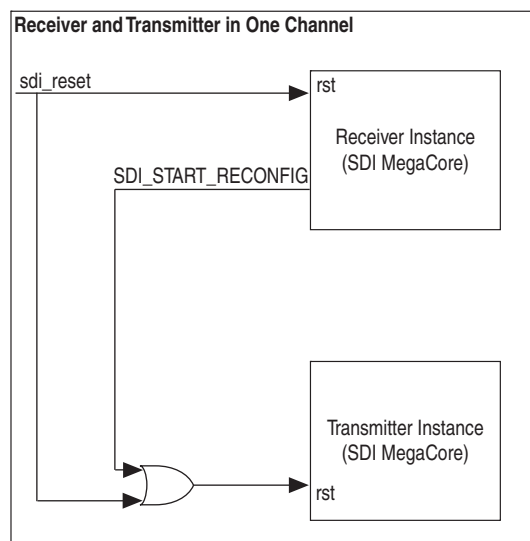
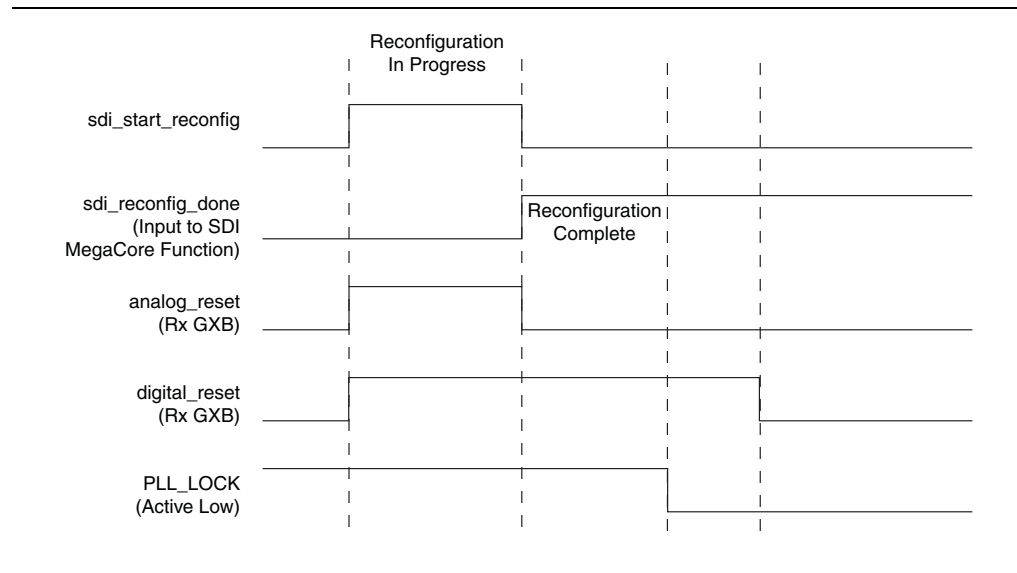

Figure 3–25 shows a timing diagram of the receiver reset sequence.

Figure 3–25. Reset Sequence of the Receiver During Reconfiguration



The following sequence of events occur for the reset sequence of the receiver:

1. The SDI MegaCore function resets the Rx transceiver (analog and digital reset are asserted) after detecting a change in the data rate.
2. The SDI MegaCore function asserts `SDI_START_RECONFIG` to make a reconfiguration request to the `ALT2GXB_RECONFIG` block. The `ALT2GXB_RECONFIG` block sets `SDI_RECONFIG_DONE` to 0, which indicates to the MegaCore function that the reconfiguration is in progress.
3. When the reconfiguration has been performed, the `ALT2GXB_RECONFIG` block sets the `SDI_RECONFIG_DONE` to logic 1, which indicates to the SDI MegaCore function to start locking to the incoming data. The analog reset of the SDI MegaCore function receiver is deasserted.
4. When the CDR PLL locks to the received data (HD/3G mode) or reference clock (SD mode) successfully, the digital reset of the SDI MegaCore function receiver is deasserted so that the receiver can continue to process valid data.
5. The SDI MegaCore function sets the `SDI_START_RECONFIG` line to 0 to indicate that the request is completed and acknowledged.

Generation of ROM Contents

For Arria GX and Stratix II GX devices, the contents of the ROM are set by `.mif`. The Quartus II software outputs the `.mif` for the configuration settings of the `ALT2GXB` instance that is set by the design.



This file generation is not performed by default. You must adjust the Fitter settings. On the Assignments menu, click **Settings**. In the **Settings** dialog box, click **Fitter Settings**, and then click **More Settings**. In the **Name** list, select **Generate GXB Reconfig MIF** and in the **Setting** list, select **On**.

For the SDI MegaCore function, the Quartus II-generated **.mif** is for 3G-SDI setup.



These **.mif** files relate to a specific ALT2GXB instance in the device. Therefore, you cannot use the same **.mif** files or ROMs for multiple ALT2GXBs in the same device.

For the SDI MegaCore function, the differences between the ALT2GXB setups are very small. Only three bits of the ROM change between the HD-SDI and SD-SDI, or 3G-SDI setups. The three bits are in word 23 and you can see in the following examples of the **.mif** files (Example 3-1 and Example 3-2).

Example 3-1. 3G-SDI ROM Content Example

```
....
22 : 1010100000011111;
23 : 0111110000010100;
24 : 0001000101101000;
....
```

Example 3-2. HD-SDI ROM Content Generated from 3G-SDI Version

```
....
22 : 1010100000011111;
23 : 011111000001101;
24 : 0001000101101000;
....
```

This particular word is static over all SDI ALT2GXB instances in the device. You can generate the **.mif** for the HD-SDI ROM from the **.mif** that the Quartus II software generates by modifying this memory word within the **.mif**.

Starting Channel Number

To correctly address each transceiver by the ALT2GXB_RECONFIG block, you must specify a starting channel number for each transceiver instance in the parameter editor. This starting channel number must meet certain criteria for the transceiver dynamic reconfiguration.



For more information about the criteria, refer to the *Arria GX Device Handbook*, *Arria II GX Device Handbook*, *Stratix II GX Device Handbook*, and *Stratix IV Device Handbook*.

Quartus II Design Flow

For Arria GX and Stratix II GX devices, SDI MegaCore function designs using transceiver dynamic reconfiguration require a two-pass compilation. The first compilation writes the ALT2GXB setup as a **.mif**. During this compilation, you must set the **.mif** ROMs in the design to have a dummy **.mif** for their initialization.

Before the second compilation, set the initialization **.mif** files of the ROMs to be generated in the first compilation. This second compilation, therefore sets up the ROMs to have the correct settings for the ALT2GXB megafunction.

This process requires the following steps:

1. Set the reconfiguration ROMs in the designs with a dummy **.mif**.
2. Run the Quartus II compilation and ensure that the software writes the **.mif** files.

3. Copy and modify the `.mif` files for the HD-SDI ROMs and edit word 23.
4. Set the appropriate ROMs to use the `.mif` files generated in steps 2 and 3.
5. Run the Quartus II compilation.

For Arria II GX and Stratix IV devices, you must set the ROMs to use the fixed `.mif` in the `example\ax2gx_tr\source\sdi_dprio_siv` directory and compile once. Ensure that you use the supporting reconfiguration code in the same directory for your design.

OpenCore Plus Time-Out Behavior

OpenCore Plus hardware evaluation can support the following two modes of operation:

- *Untethered*—the design runs for a limited time
- *Tethered*—requires a connection between your board and the host computer. If tethered mode is supported by all megafunctions in a design, the device can operate for a longer time or indefinitely

All megafunctions in a device time out simultaneously when the most restrictive evaluation time is reached. If there is more than one megafunction in a design, a specific megafunction's time-out behavior may be masked by the time-out behavior of the other megafunctions.



For MegaCore functions, the untethered time-out is 1 hour; the tethered time-out value is indefinite.

Your design stops working after the hardware evaluation time expires and the `rst` signal goes high.



For more information on OpenCore Plus hardware evaluation, refer to “OpenCore Plus Evaluation” on page 1–5 and *AN320: OpenCore Plus Evaluation of Megafunctions*.

Signals

Table 3–12 lists the receiver clock signals.

Table 3–12. Receiver Clock Signals (Part 1 of 2)

Signal	Direction	Description
<code>gxb2_cal_clk</code>	Input	Calibration clock for Arria GX and Stratix II GX transceivers only.
<code>gxb4_cal_clk</code>	Input	Calibration clock for Arria II GX, Arria V, Cyclone IV GX, HardCopy IV, and Stratix IV transceivers only.
<code>rx_sd_oversample_clk_in</code>	Input	67.5-MHz oversample clock input. SD-SDI only.
<code>rx_serial_refclk⁽¹⁾</code>	Input	Transceiver training clock for HD-SDI, dual standard and triple standard.
<code>rx_serial_refclk1</code>	Input	Secondary transceiver training clock. Clock frequency of 74.175 MHz for HD-SDI, or clock frequency of 148.35 MHz for 3G-SDI, dual standard and triple standard. Available only when you use a Cyclone IV GX device.

Table 3–12. Receiver Clock Signals (Part 2 of 2)

Signal	Direction	Description
rx_coreclk	Input	Receiver controller clock input. For Cyclone IV GX devices only. The frequency of this clock must be the same as rx_serial_refclk. Because of hardware constraint, the transceiver PLL and core logic cannot share the same clock input pin if they use transceiver PLL6 and PLL7.
refclk_rate ⁽²⁾	Input	This signal is related to the rx_video_format signal. Detects the received video standard. Set input to 0 for a 148.35-MHz receiver serial reference clock. Set input to 1 for 148.5-MHz RX serial reference clock.
gxb_tx_clkout	Output	Transmitter clock out of transceiver. This clock is the output of the voltage-controlled oscillator (VCO) and is used as a parallel clock for the transmitter. It connects internally to the tx_clkout signal of the ALTGX or ALT2GXB megafunction.
rx_clk	Output	Transceiver CDR clock.
rx_sd_oversample_clk_out	Output	67.5-MHz oversample clock output for cascading MegaCore functions. SD-SDI only.
rx_video_format	Output	This signal is related to the refclk_rate signal. Indicates the format for the received video. The rx_video_format value is valid after the frame locked signal is asserted. For more information about the video specification, refer to Table 3–17 .

Notes to Table 3–12:

- (1) You must tie the tx_serial_refclk and rx_serial_refclk signals together if you generate an SDI duplex using the Stratix V or Arria V devices.
- (2) For Cyclone IV GX devices, set the refclk_rate according to the rx_coreclk frequency.

[Table 3–13](#) lists the transmitter clock signals.

Table 3–13. Transmitter Clock Signals

Signal	Direction	Description
tx_pclk	Input	Transmitter parallel clock input. For SD-SDI = 27 MHz; for HD-SDI = 74 MHz and for 3G-SDI = 148.5 MHz.
tx_serial_refclk ⁽¹⁾	Input	Transceiver reference clock input. Low jitter. Refer to Table 3–5 .
tx_serial_refclk1	Input	Optional port for transceiver reference clock input. Low jitter. Similar to tx_serial_refclk. Only available for Arria II, Stratix IV GX, and HardCopy IV GX devices.

Note to Table 3–13:

- (1) You must tie the tx_serial_refclk and rx_serial_refclk signals together if you generate an SDI duplex using Arria V or Stratix V devices.

Table 3-14 lists the transceiver PHY management clock and reset signals.

Table 3-14. Transceiver PHY Management Signals ⁽¹⁾

Signal	Direction	Description
phy_mgmt_clk	Input	Avalon-MM clock input for the transceiver PHY management interface. Use the same clock for the PHY management interface and transceiver reconfiguration. The frequency range is 100-125 MHz to meet the specification of the transceiver reconfiguration clock.
phy_mgmt_clk_reset	Input	Reset signal for the transceiver PHY management interface. This signal is active high and level sensitive. This signal can be tied to the same reset port as tx_rst or rx_rst signal in simplex mode. In duplex mode, this reset signal acts as a global reset for both the transmitter and receiver. If you require a different reset for the transmitter and receiver, separate this signal from the tx_rst and rx_rst signal.

Note to Table 3-14:

(1) The transceiver PHY management clock and reset signals are available for Stratix V and Arria V devices only.

Table 3-15 lists the soft transceiver clock signals.

Table 3-15. Soft Transceiver Clock Signals

Signal	Direction	Description
rx_sd_refclk_337	Input	Soft transceiver 337.5-MHz sampling clock.
rx_sd_refclk_337_90deg	Input	Soft transceiver 337.5-MHz sampling clock with 90° phase shift.
rx_sd_refclk_135	Input	Soft transceiver 135-MHz parallel clock for receiver.
tx_sd_refclk_270	Input	Soft transceiver 270-MHz parallel clock for transmitter.

Table 3-16 lists the interface signals.

Table 3-16. Interface Signals (Part 1 of 5)

Signal	Width	Direction	Description
enable_crc	[(N-1):0]	Input	Enables CRC insertion for HD-SDI and 3G-SDI.
enable_hd_search	1	Input	Enables search for HD-SDI signal in dual or triple standard mode.
enable_sd_search	1	Input	Enables search for SD-SDI signal in dual or triple standard mode.
enable_3g_search	1	Input	Enables search for 3G-SDI signal in triple standard mode.
enable_ln	[(N-1):0]	Input	Enables line number insertion for HD-SDI and 3G-SDI modes.
en_sync_switch	1	Input	Enables aligner and format blocks to realign immediately so that the downstream is completely non-disruptive.
rst_rx	1	Input	Reset signal, which holds the receiver in reset. It must be synchronous to rx_serial_refclk clock domain for the receiver. Issues a reset to the SDI MegaCore function after power-up to ensure reliable operation. Refer to Figure 3-29 . For HD-SDI dual link receiver, assert this signal when both link A and link B are ready for the first time.

Table 3-16. Interface Signals (Part 2 of 5)

Signal	Width	Direction	Description
rst_tx	1	Input	Reset signal, which holds the transmitter in reset. The reset synchronization for the transmitter is handled within the SDI MegaCore function. The video mode (<code>tx_std</code>) and clocks must be set up and stable before device bring-up or core reset. Issues a reset to the SDI MegaCore function after power-up to ensure reliable operation. Refer to Figure 3-30 .
rx_serial_refclk_clkswitch	1	Input	Reference clock switching. Available only when you use a Cyclone IV GX device. Toggle between <code>rx_serial_refclk</code> and <code>rx_serial_refclk1</code> at every positive edge triggered.
rx_protocol_clk	$[(N-1):0]$	Input	External clock for protocol data.
rx_protocol_hd_sdn	$[(N-1):0]$	Input	Selection of HD-SDI or SD-SDI processing for dual or triple standard protocol block. This signal only appears on dual or triple standard protocol blocks and indicates 3G-SDI(1), HD-SDI(1) or SD-SDI(0) data on the <code>rx_protocol_in</code> signal. You must connect this signal to the <code>rx_std_flag_hd_sdn</code> output of the transceiver block in a split protocol/transceiver design.
rx_protocol_in	$[(20N-1):0]$	Input	External data in for protocol only mode.
rx_protocol_locked	$[(N-1):0]$	Input	Input to transceiver control logic. When active, this signal indicates to the transceiver control logic that the protocol blocks are locked, to stop the transceiver search algorithm at the current rate.
rx_protocol_rst	$[(N-1):0]$	Input	Reset for the protocol block. This signal resets the protocol blocks. You can connect this signal to the <code>rx_status[1]</code> pin (<code>sdi_reset</code>) in a split transceiver/protocol design.
rx_protocol_valid	$[(N-1):0]$	Input	External data valid in for protocol only mode.
rx_protocol_rate	[1:0]	Input	Input to the protocol block. This signal indicates the received video standard to the protocol block. However, this signal does not distinguish between 3G-SDI Level A and 3G-SDI Level B streams. The aligner block in the protocol block distinguishes the 3G-SDI Level A and 3G-SDI Level B streams. You must connect this signal to the <code>rx_std</code> port of the transceiver block in a split transceiver/protocol design.
rx_xcvr_trs_lock	$[(N-1):0]$	Input	Input to transceiver control logic. You must connect this signal to the <code>rx_status[3]</code> pin (<code>trs_locked</code>) of the protocol only receiver block.
sdi_rx	$[(N-1):0]$	Input	Serial input.

Table 3-16. Interface Signals (Part 3 of 5)

Signal	Width	Direction	Description
txdata	$[(20N - 1):0]$	Input	User-supplied transmitter parallel data. SD-SDI uses 9:0; HD-SDI uses $20N - 1:0$. SD: bits 19:10 unused; bits 9:0 Cb, Y, Cr, Y multiplex HD: bits 19:10 Y; bits 9:0 C Dual link: bits 39:30 Y link B; bits 29:20 C link B; bits 19:10 Y link A, bits 9:0 C link A 3G-SDI Level A: bits 19:10 Y; bits 9:0 C 3G-SDI Level B: bits 19:10 Cb, Y, Cr, Y multiplex (link A); bits 9:0 Cb, Y, Cr, Y multiplex (link B)
tx_ln	[21:0]	Input	Transmitter line number. For use in HD-SDI and 3G-SDI line number insertion. HD-SDI: bits 21:11 11'd0; bits 10:0 LN Dual link: bits 21:11 LN link B; bits 10:0 LN link A 3G-SDI Level A: bits 21:11 11'd0; bits 10:0 LN 3G-SDI Level B: bits 21:11 LN link A; bits 10:0 LN link B Refer to Figure 3-31 and Figure 3-32 .
tx_trs	$[(N - 1):0]$	Input	Transmitter TRS input. For use in HD-SDI LN and CRC insertion. Assert on first word of both EAV and SAV TRSs. Refer to Figure 3-31 and Figure 3-32 .
tx_std	[1:0]	Input	Transmitter standard. 00 for SD-SDI; 01 for HD-SDI; 11 for 3G-SDI Level A, and 10 for 3G-SDI Level B. This signal must be set up and stable prior to device bring-up or core reset. Refer to Figure 3-31 and Figure 3-32 .
trs_loose_lock	$[(N - 1):0]$	Output	TRS locking signal for protocol only receiver mode. You can connect this signal to the rx_protocol_locked pin of the transceiver only receiver block.
crc_error_y	[1:0]	Output	CRC error on luma channel. HD-SDI: bit 1 unused; bit 0 crc_error_y Dual link: bit 1 link B crc_error_y; bit 0 link A crc_error_y 3G-SDI Level A: bit 1 unused; bit 0 crc_error_y 3G-SDI Level B: bit 1 link A crc_error_y; bit 0 link B crc_error_y Refer to Figure 3-33 .
crc_error_c	[1:0]	Output	CRC error on chroma channel. HD-SDI: bit 1 unused; bit 0 crc_error_c Dual link: bit 1 link B crc_error_c; bit 0 link A crc_error_c 3G-SDI Level A: bit 1 unused; bit 0 crc_error_c 3G-SDI Level B: bit 1 link A crc_error_c; bit 0 link B crc_error_c Refer to Figure 3-33 .

Table 3-16. Interface Signals (Part 4 of 5)

Signal	Width	Direction	Description
rx_AP	[1:0]	Output	This is an active picture interval timing signal. The receiver asserts this signal when the active picture interval is active. HD-SDI/SD-SDI: bit 1 unused; bit 0 rx_ap Dual link: bit 1 link B unused; bit 0 link A rx_ap 3G-SDI Level A: bit 1 unused; bit 0 rx_ap 3G-SDI Level B: bit 1 link A rx_ap; bit 0 link B rx_ap
rxdata	[(20N-1):0]	Output	Receiver parallel data. SD-SDI uses 9:0; HD-SDI uses 20N-1:0. SD-SDI bits 19:10 unused; bits 9:0 Cb, Y, Cr, Y multiplex HD-SDI bits 19:10 Y; bits 9:0 C Dual link: bits 39:30 Y link B; bits 29:20 C link B; bits 19:10 Y link A, bits 9:0 C link A 3G-SDI Level A: bits 19:10 Y; bits 9:0 C 3G-SDI Level B: bits 19:10 Cb, Y, Cr, Y multiplex (link A); bits 9:0 Cb, Y, Cr, Y multiplex (link B)
rx_data_valid_out	[1:0]	Output	Data valid from the oversampling logic. Asserted to indicate current data on rxdata is valid. Bit 0 of this bus indicates valid data on rxdata. When receiving SMPTE 425M-B signals in 3G-SDI or triple standard, bit 1 indicates that data on rxdata is from virtual link A; bit 0 indicates the data is from virtual link B. Refer to Figure 3-34 and Figure 3-35, and SMPTE425M-B 2006 3Gb/s Signal/Data Serial Interface – Source Image Format Mapping.
rx_F	[1:0]	Output	This is a field bit timing signal. This signal indicates which video field is currently active. For interlaced frame, 0 means first field (F0) while 1 means second field (F1). For progressive frame, the value is always 0. HD-SDI/SD: bit 1 unused; bit 0 rx_f Dual link: bit 1 unused; bit 0 rx_f 3G-SDI Level A: bit 1:0 unused 3G-SDI Level B: bit 1:0 unused
rx_H	[1:0]	Output	This is a horizontal blanking interval timing signal. The receiver asserts this signal when the horizontal blanking interval is active. HD-SDI/SD-SDI: bit 1 unused; bit 0 rx_h Dual link: bit 1 unused; bit 0 rx_h 3G-SDI Level A: bit 1 unused; bit 0 rx_h 3G-SDI Level B: bit 1 link A rx_h; bit 0 link B rx_h

Table 3-16. Interface Signals (Part 5 of 5)

Signal	Width	Direction	Description
rx_ln	[21:0]	Output	Receiver line number output. HD-SDI: bits 21:11 unused; bits 10:0 LN Dual link: bits 21:11 unused; bits 10:0 LN 3G-SDI Level A: bits 21:11 unused; bits 10:0 LN 3G-SDI Level B: bits 21:11 LN link A; bits 10:0 LN link B
rx_std_flag_hd_sdn	1	Output	Indicates received standard for dual or triple standard only. HD-SDI = 1; SD-SDI = 0.
rx_v	[1:0]	Output	This is a vertical blanking interval timing signal. The receiver asserts this signal when the vertical blanking interval is active. HD-SDI/SD-SDI: bit 1 unused; bit 0 rx_v Dual link: bit 1 unused; bit 0 rx_v 3G-SDI Level A: bit 1 unused; bit 0 rx_v 3G-SDI Level B: bit 1 link A rx_v; bit 0 link B rx_v
rx_xyz	1	Output	Receiver output that indicates current word is XYZ word.
xyz_valid	1	Output	Receiver output that indicates current TRS format is legal (XYZ word is correct).
rx_eav	1	Output	Receiver output that indicates current TRS is EAV.
rx_trs	1	Output	Receiver output that indicates current word is TRS. This signal is asserted at the first word of 3FF 000 000 TRS.
sdi_tx	[(N-1):0]	Output	Serial output.
tx_protocol_out	[(20N-1):0]	Output	Data out (protocol only mode).

Figure 3-26 through Figure 3-28 illustrate the input and output signals in Table 3-16 for SDI triple standard instances.

Figure 3-26. Interface Signals for SDI Triple Standard Receiver

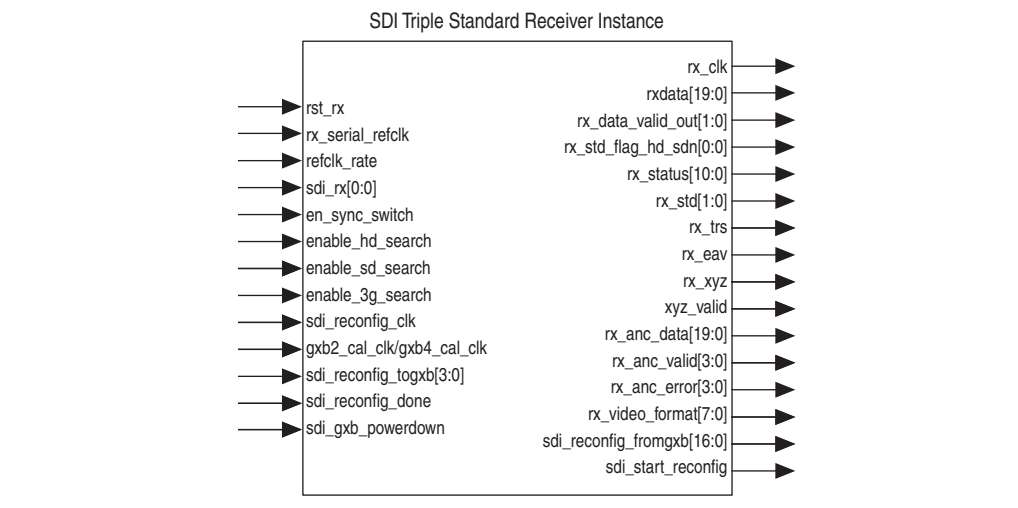

Figure 3-27. Interface Signals for SDI Triple Standard Transmitter

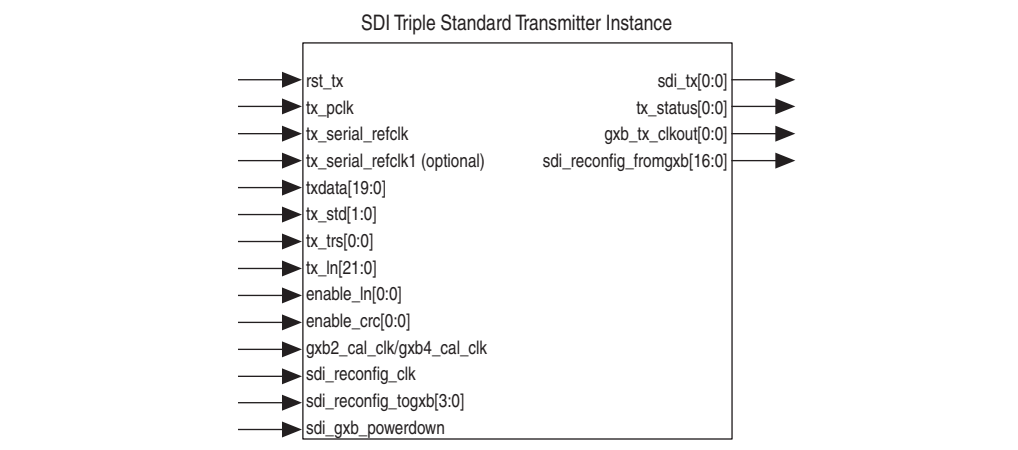

Figure 3–28. Interface Signals for SDI Triple Standard Duplex Instance

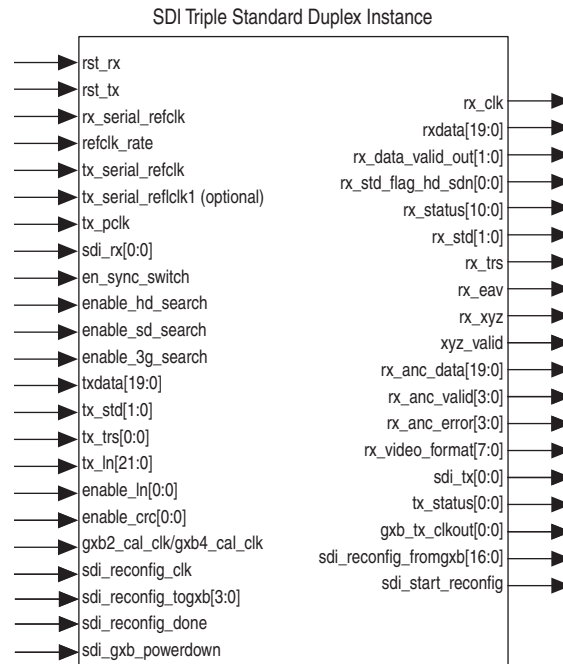
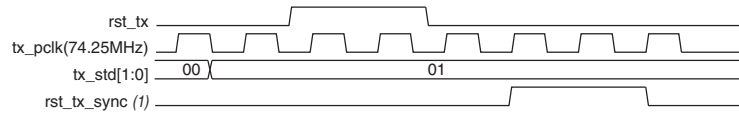

Figure 3–29 through Figure 3–37 show the behavior of some signals in Table 3–16.

Figure 3–29. Power-up Reset for the Receiver



Figure 3–30. Power-up Reset for the Transmitter



Note to Figure 3–30:

- (1) Internally synchronized reset for the transmit circuits.

Figure 3–31. Behavior of tx_std, tx_trs, and tx_ln Signals—425MA

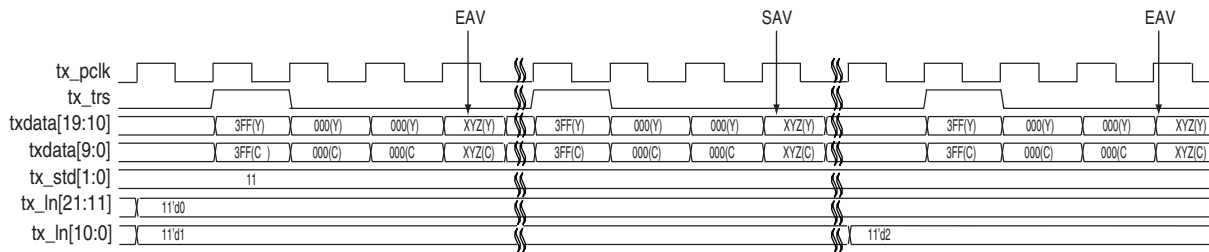

Figure 3-32. Behavior of tx_std, tx_trs, and tx_In Signals—425MB

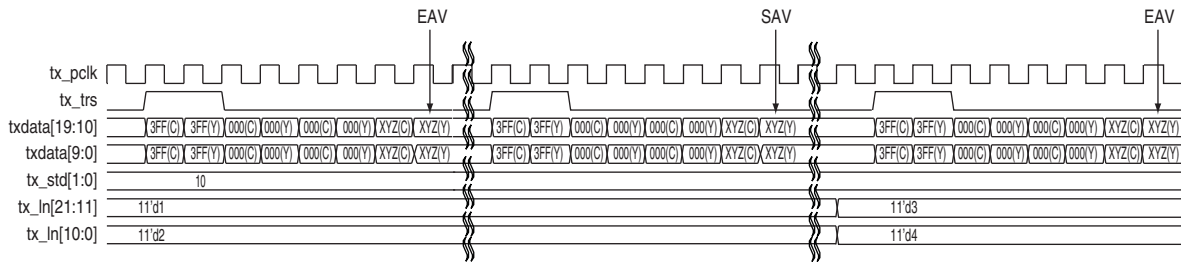
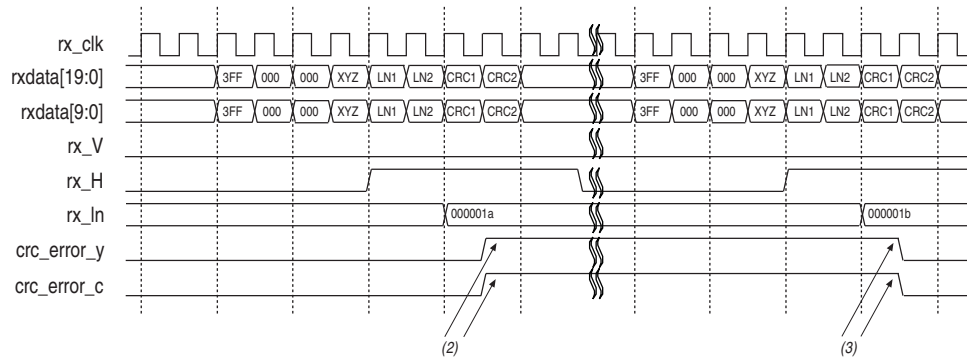

Figure 3-33. Behavior of crc_error_y and crc_error_c Signals (1)



Notes to Figure 3-33:

- (1) When a CRC error occurs, the `crc_error_y` or `crc_error_c` signal goes high until the next line. For HD, Dual Link, and 3G Level A, only `crc_error_y[0]` and `crc_error_c[0]` signals are used. For 3G Level B, `crc_error_y[0]` and `crc_error_c[0]` signals are used for link B, and `crc_error_y[1]` and `crc_error_c[1]` signals are used for link A.
- (2) The CRC error signals are asserted after the CRC data checked, when the `rx_H` signal is high. A high CRC signal indicates that there is error in the previous line data. In this case, both Y and C have CRC error.
- (3) The CRC error signals are deasserted on the next line after the CRC data is checked.

Figure 3-34. Behavior of rx_data_valid Signal—425MA

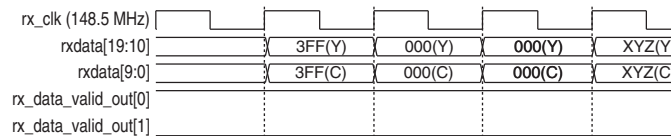

Figure 3-35. Behavior of rx_data_valid Signal—425MB

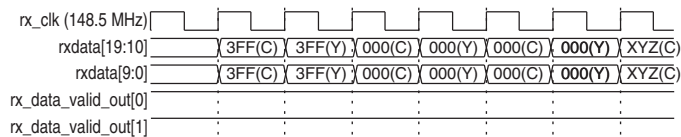

Figure 3-36. Behavior of rx_trsr, rx_xyz, xyz_valid and rx_eavr Signals—425MA

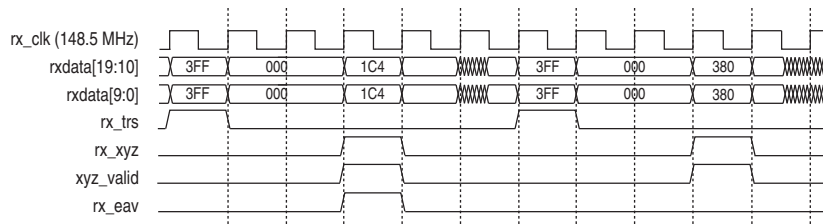

Figure 3-37. Behavior of rx_trsr, rx_xyz, xyz_valid and rx_eavr Signals—425MB

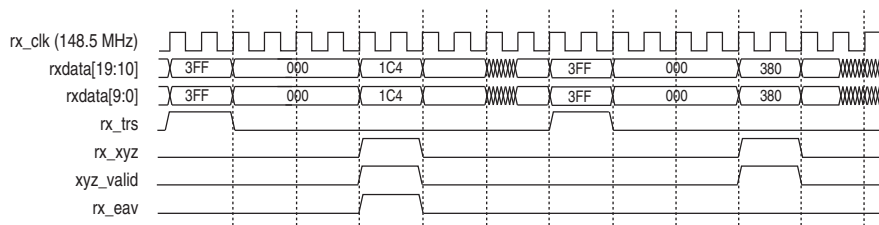

Table 3-17 lists the 8-bit receiving video format specification.

Table 3-17. Receiving Video Format Specification (Part 1 of 2)

Video Standard	Total Active Lines	Word per Total Line	Rate	rx_video_format [7:5]	rx_video_format [4]	rx_video_format [3:0]
					Progressive/Interlace	Frame Rate
SD	720	—	—	0	0	8
720p60		1650	60	2	1	7
720p59.94			59.94			6
720p50		1980	50			5
720p30		3300	30			4
720p29.97			29.97			3
720p25		3960	25			2
720p24		4125	24			1
720p23.97			23.97			0
1035i30	1035	2200	30			3
1035i29.97			29.97	3	0	3
1080i25	1080	2376	25	4	0	2
1080i60		2200	60	1		7
1080i59.94			59.94			6
1080i50		2640	50			5
1080i24		2750	24			1
1080i23.97			23.97			0

Table 3–17. Receiving Video Format Specification (Part 2 of 2)

Video Standard	Total Active Lines	Word per Total Line	Rate	rx_video_format [7:5]	rx_video_format [4]	rx_video_format [3:0]
					Progressive/Interlace	Frame Rate
1080p60	1080	2200	60	1	1	7
1080p59.94			59.94			6
1080p50		2640	50			5
1080p30	1080	2200	30	1	1	4
1080p29.97			29.97			3
1080p25		2640	25			2
1080p24		2750	24			1
1080p23.97			23.97			0

Table 3–18 lists the status signals.

Table 3–18. Status Signals (Part 1 of 2)

Signal	Width	Direction	Description
rx_anc_data	[(20N – 1):0]	Output	Received ancillary data. SD-SDI: bits 19:10 unused; bits 9:0 Cb, Y, Cr, Y multiplex HD-SDI: bits 19:10 Y; bits 9:0 C Dual link: bits 39:30 Y (link B); bits 29:20 C (link B); bits 19:10 Y (link A); bits 9:0 C (link A) 3G-SDI Level A: bits 19:10 Y; bits 9:0 C 3G-SDI Level B: bits 19:10 Cb, Y, Cr, Y multiplex (link A); bits 9:0 Cb, Y, Cr, Y multiplex (link B)
rx_anc_error	[3:0]	Output	Ancillary data or checksum error. SD-SDI: bits 3:1 unused; bit 0 rx_anc_error HD-SDI: bits 3:2 unused; bit 1 Y; bit 0 C Dual link: bit 3 Y (link B); bit 2 C (link B); bit 1 Y (link A); bit 0 C (link A) 3G-SDI Level A: bits 3:2 unused; bit 1 Y; bit 0 C 3G-SDI Level B: bit 3 Y (link A); bit 2 C (link A); bit 1 Y (link B); bit 0 C (link B)
rx_anc_valid	[3:0]	Output	Ancillary data valid. Asserted to accompany data ID (DID), secondary data ID/data block number (SDID/DBN), data count (DC), and user data words (UDW) on rx_anc_data. SD-SDI: bits 3:1 unused; bit 0 rx_anc_valid HD-SDI: bits 3:2 unused; bit 1 Y; bit 0 C Dual link: bit 3 Y (link B); bit 2 C (link B); bit 1 Y (link A); bit 0 C (link A) 3G-SDI Level A: bits 3:2 unused; bit 1 Y; bit 0 C 3G-SDI Level B: bit 3 Y (link A); bit 2 C (link A); bit 1 Y (link B); bit 0 C (link B)

Table 3-18. Status Signals (Part 2 of 2)

Signal	Width	Direction	Description
rx_status	[10:0]	Output	<p>Receiver status:</p> <ul style="list-style-type: none"> ■ rx_status[10] dual link ports aligned ■ rx_status[9] link B frame locked ■ rx_status[8] link B TRS locked (six consecutive TRSs with same timing) ■ rx_status[7] link B alignment locked (a TRS has been spotted and word alignment performed) ■ rx_status[6] link B receiver in reset ■ rx_status[5] link B transceiver PLL locked ■ rx_status[4] link A Frame locked ■ rx_status[3] link A TRS locked (six consecutive TRSs with same timing) ■ rx_status[2] link A alignment locked (a TRS has been spotted and word alignment performed) ■ rx_status[1] link A receiver in reset ■ rx_status[0] link A transceiver PLL locked <p>For non HD-SDI dual link versions, only bits [4:0] are active.</p> <p>For transceiver only receiver block in HD-SDI dual link versions, only bits [6:5] and [1:0] are active.</p> <p>This signal is active high for Stratix GX devices and active low for other Altera transceiver-based device families. This signal indicates lock of the PLL when the transceiver is training from a refclk source. This signal may oscillate when the transceiver is correctly locked to the incoming data in HD-SDI or 3G-SDI modes. In SD-SDI modes, remain this signal at PLL locked at all times.</p> <p>For rx_status[3] and rx_status[8], the TRS spacing is not required to meet a particular SMPTE standard, but it must be consistent over time for this signal to remain active.</p>
tx_status	[(N-1):0]	Output	<p>Transmitter status, which indicates the transmitter PLL has locked to the tx_serial_refclk signal. This signal is active high for Stratix GX devices and active low for other Altera transceiver-based device families.</p>

Figure 3-38 and Figure 3-42 show the behavior of the rx_anc_data signal in Table 3-18 on page 3-50.

Figure 3-38. Behavior of rx_anc_data/valid/error Signals—425MA

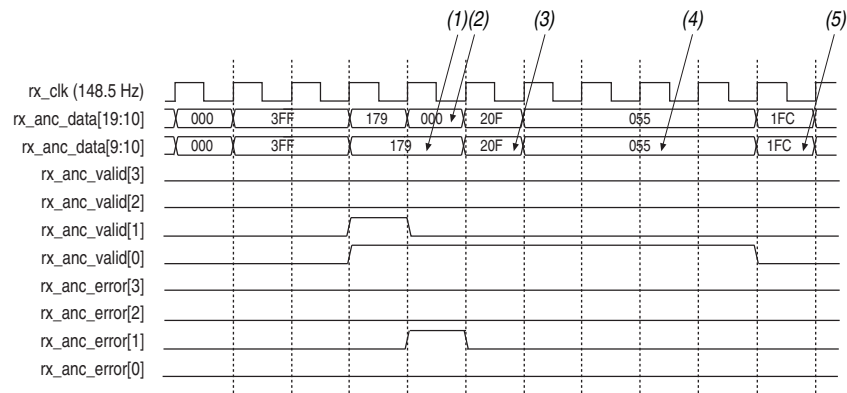

Notes to Figure 3-38:

- (1) Sequence starts with Data Identifier (DID), followed by Secondary Data Identifier (SDID) or Data Block Number (DBN).
- (2) The Y channel goes wrong.
- (3) Data Count (DC).
- (4) User data word (UDW) up to 255 words.
- (5) Checksum word.

Figure 3-39. Behavior of rx_anc_data/valid/error Signals—425MB

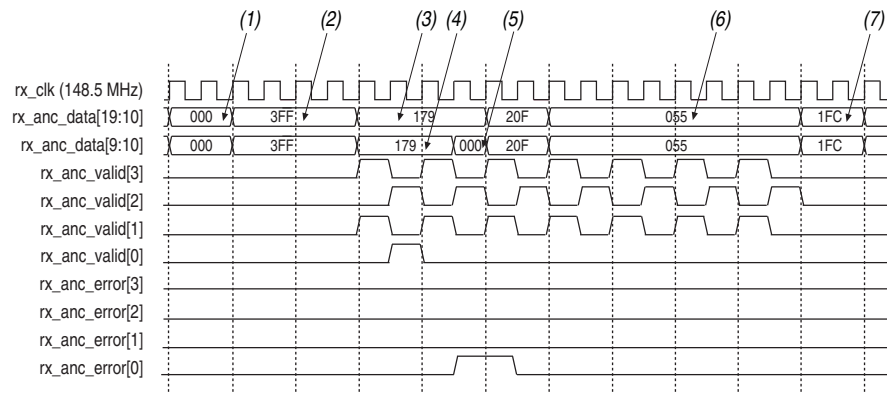

Notes to Figure 3-39:

- (1) 000 (C), 000 (Y)
- (2) 3FF (C), 3FF (Y), 3FF (C), 3FF (Y)
- (3) Sequence starts with Data Identifier (DID), followed by Secondary Data Identifier (SDID) or Data Block Number (DBN).
- (4) The Y channel of Link B goes wrong.
- (5) Data Count (DC) word.
- (6) User data word (UDW) up to 255.
- (7) Checksum word.

Figure 3-40. Behavior of rx_anc_data/valid/error Signals—HD

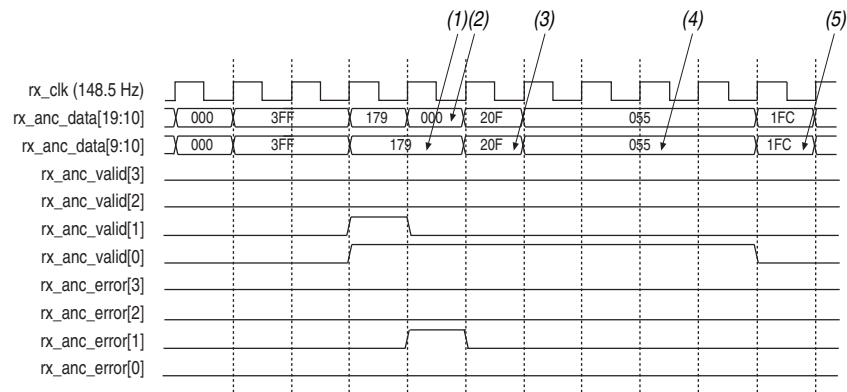

Notes to Figure 3-40:

- (1) Sequence starts with Data Identifier (DID), followed by Secondary Data Identifier (SDID) or Data Block Number (DBN).
- (2) The Y channel goes wrong.
- (3) Data Count (DC) word.
- (4) User data word (UDW) up to 255 words.
- (5) Checksum word.

Figure 3-41. Behavior of rx_anc_data/valid/error Signals Without Error—SD

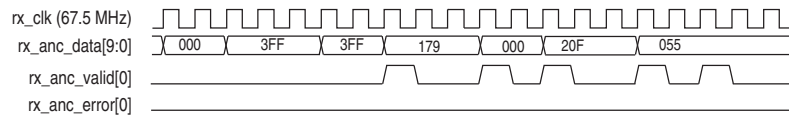

Figure 3-42. Behavior of rx_anc_data/valid/error Signals With Error—SD

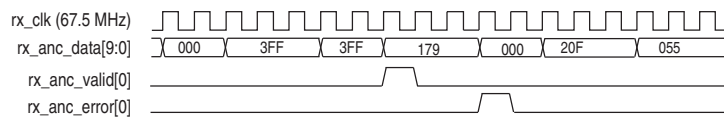

Table 3–19 lists the signals that handle the transceiver dynamic reconfiguration operation.

Table 3–19. Transceiver Dynamic Reconfiguration Signals (Part 1 of 2)

Signal	Direction	Description
SDI_RECONFIG_DONE	Input	Indicates back to MegaCore function that reconfiguration has finished. This signal is not required for PLL reconfiguration.
SDI_RECONFIG_TOGXB (1), (3), (4)	Input	Data input for the embedded transceiver instance. (2), (5) Data width: <ul style="list-style-type: none"> ■ For all devices except Arria V, Cyclone V, and Stratix V = SDI_RECONFIG_TOGXB [3:0] ■ SDI_RECONFIG_TOGXB [3] is negligible for Arria GX and Stratix II GX. ■ For Arria V, Cyclone V, and Stratix V devices = SDI_RECONFIG_TOGXB [(140N-1):0] or SDI_RECONFIG_TOGXB [(70N-1):0]—if the receiver in the interface settings is selected.
SDI_RECONFIG_CLK (3)	Input	Clock input for the embedded transceiver instance. (2) This signal is not applicable for Arria V, Cyclone V, and Stratix V devices.
SDI_GXB_POWERDOWN	Input	Powers down and resets circuits in all transceiver instance. (6) This signal is not applicable for Arria V, Cyclone V, and Stratix V devices.
SDI_START_RECONFIG	Output	Request from MegaCore function to start reconfiguration.
SDI_RECONFIG_FROMGXB (1), (3), (4)	Output	Data output from embedded transceiver instance. (2), (5) Data width: <ul style="list-style-type: none"> ■ For all devices except Arria V, Cyclone V, and Stratix V = SDI_RECONFIG_FROMGXB [(17N-1):0] ■ SDI_RECONFIG_FROMGXB [16:1] are negligible for Arria GX and Stratix II GX ■ SDI_RECONFIG_FROMGXB [16:5] are negligible for Cyclone IV GX ■ For Arria V, Cyclone V, and Stratix V devices = SDI_RECONFIG_FROMGXB [(92N-1):0] or SDI_RECONFIG_FROMGXB [(46N-1):0] if the receiver in the interface settings is selected.
RX_STD [1:0]	Output	Receive video standard. 00 = SD-SDI, 01 = HD-SDI, 10 = 3G-SDI. The SDI MegaCore function can recover both <i>SMPTE 425M-A</i> and <i>425M-B</i> formatted streams. The receiver indicates which format it detects by setting the level of the rx_std bus: <ul style="list-style-type: none"> ■ rx_std [1:0] = 2'b11 = <i>425M-A</i> ■ rx_std [1:0] = 2'b10 = <i>425M-B</i>
PLL_ARESET (7), (8), (9)	Input	Drives the areset signal on the transceiver PLL to be reconfigured. This signal indicates that the transceiver PLL must be reset.
PLL_CONFIGUPDATE (7), (8), (9)	Input	Drives the configupdate signal on the transceiver PLL to be reconfigured.

Table 3-19. Transceiver Dynamic Reconfiguration Signals (Part 2 of 2)

Signal	Direction	Description
PLL_SCANCLK (7), (8), (9)	Input	Drives the <code>scanclk</code> signal on the transceiver PLL to be reconfigured.
PLL_SCANCLKENA (7), (8), (9)	Input	Acts as a clock enable for the <code>scanclk</code> signal on the transceiver PLL to be reconfigured.
PLL_SCANDATA (7), (8), (9)	Input	Drives the <code>scandata</code> signal on the transceiver PLL to be reconfigured. This signal holds the scan data input to the transceiver PLL for the dynamically reconfigurable bits.
PLL_SCANDONE (7), (8), (9)	Output	Determines when the transceiver PLL is reconfigured.
PLL_SCANDATAOUT (7), (8), (9)	Output	This signal holds the transceiver PLL scan data output from the dynamically reconfigurable bits.

Notes to Table 3-19:

- (1) These signals must be connected directly to a reconfiguration megafunction.
- (2) The transceivers are available for Arria GX, Arria II GX, Arria V, Cyclone IV GX, Cyclone V, Hardcopy IV GX, Stratix II GX, Stratix IV, and Stratix V devices only.
- (3) SDI transmitters do not require the use of transceiver dynamic reconfiguration but to enable the cores to merge into a transceiver quad that has transceiver dynamic reconfiguration enabled, you must connect these ports correctly.
- (4) In the Quartus II software version 8.1 and later, the Stratix IV transceivers requires receiver buffer calibration through an `ALTGX_RECONFIG` (transceiver dynamic reconfiguration) controller. The additional `RECONFIG` port bits are used for receiver buffer calibration. You must connect these ports to the `ALTGX_RECONFIG` controller externally. For further information on the receiver buffer calibration, refer to the *Stratix IV Dynamic Reconfiguration* chapter in volume 2 of the *Stratix IV Device Handbook*. If you are using the Quartus II software version 10.1, make sure to upgrade the SDI MegaCore function to version 10.1 as well.
- (5) N represents the number of channels instantiated.
- (6) The `SDI_GXB_POWERDOWN` signal of all the instances that are to be combined in a single transceiver block must be connected to a single point (same input or same logic). Any difference in the driving logic prevents the instances from being combined in a single transceiver block.
- (7) This signal must be connected directly to the `ALTPLL_RECONFIG` megafunction, and only exposed to the top level when you select the **Use PLL reconfiguration for transceiver dynamic reconfiguration** option in the SDI parameter editor.
- (8) The transceivers are available for Cyclone IV GX devices only.
- (9) You require `rx_std` and `sdi_start_reconfig` signals for PLL reconfiguration.

Parameters

The parameters can only be set in the MegaWizard Plug-In Manager (refer to “Parameterizing” on page 2-5).

Table 3-20 lists the protocol options.

Table 3-20. Protocol Options

Parameter	Value	Description
Video standard	SD-SDI, HD-SDI, 3G-SDI, HD-SDI dual link, dual or triple standard SDI	<p>Selection of HD-SDI or SD-SDI.</p> <p>Selecting HD-SDI switches in LN insertion and extraction and CRC generation and extraction blocks; selecting SD-SDI switches out LN insertion and extraction and CRC generation and extraction blocks.</p> <p>Selecting SD-SDI also includes oversampling logic.</p> <p>Selecting dual or triple standard SDI includes the processing blocks for both SD-SDI and HD-SDI standards. In addition, logic for bypass paths and logic to automatically switch between the input standards is included.</p>
Interface settings	Bidirectional, receiver, transmitter	<p>Selects the ports to be receiver, transmitter, or bidirectional. It switches in or out the receiver and transmitter supporting logic appropriately.</p> <p>The same setting is applied to all channels in the variation.</p> <p>If you want some to be transmitter and some to be duplex, simply create two different MegaCore variations.</p>

Table 3-21 lists the transceiver options.

Table 3-21. Transceiver Options

Parameter	Value	Description
Transceiver and protocol	Generate transceiver and protocol blocks, generate transceiver block only, or generate protocol block only	Selects transceiver or protocol blocks or both. When non-GX device is chosen, only SD-SDI protocol block is permitted. If you want to generate HD-SDI or 3G-SDI protocol block, you must select a GX device.
Use soft logic for transceiver	On or off	<p>Uses soft logic to implement the transceiver logic, rather than using Stratix II GX, Stratix IV or Stratix GX transceivers. SD-SDI only.</p> <p>For example, if you run out of hard transceivers in your device, you can implement the function in soft logic. If you have spare transceivers in a device, you may wish to use them.</p>
Starting channel number	0, 4, 8, ..., 156	Dual or triple standard only. Each dual or triple standard SDI must have a unique starting channel number. This parameter is not applicable for Stratix V, Arria V, and Cyclone V devices.

Table 3–21. Transceiver Options

Parameter	Value	Description
Use PLL reconfiguration for transceiver dynamic reconfiguration	On or off	Dual or triple standard, and Cyclone IV GX devices only. You must turn on this option if you select an EP4CGX110 or EP4CGX150 device.
Enable TX PLL select for 1/1.000 and 1/1.001 data rate reconfiguration	On or off	Enables an additional input port for transmitter serial reference clock. Available for Arria II, Stratix IV, and HardCopy IV devices only.

Table 3–22 shows the receiver/transmitter options.

Table 3–22. Receiver/Transmitter Options

Parameter	Value	Description
CRC error output	On or off	Turns on or off CRC monitoring (HD-SDI and 3G-SDI only).
SDI synchronization output	On or off	Provides synchronization outputs.
Tolerance to consecutive missed EAV/SAV	0, 1, 2, ..., 15	Receiver protocol only. Allows you to set the number of consecutive missing EAVs to be tolerated in the incoming video. Specify a higher value if you want the receiver core to tolerate more errors. If you want the receiver core not to tolerate any errors, set this option to 0 .
Two times oversample mode	On or off	HD-SDI transmitter only. When turned on, runs the transceiver at twice the rate and has improved jitter performance. Requires 148.5-MHz <code>tx_serial_refclk</code> reference clock.

MegaCore Verification

The MegaCore verification involves testing to the following standards:

- For the SD-SDI to *SMPTE259M-1997 10-Bit 4:2:2 Component Serial Digital Interface*
- For the HD-SDI to *SMPTE292M-1998 Bit-Serial Digital Interface for High Definition Television Systems*

The SDI Audio IP cores ease the development of video and image processing designs. For some instances, you combine the audio and video into one digital signal, and at other times you process the audio and video signals separately.

You can use the following cores to embed, extract or convert audio:

- SDI Audio Embed MegaCore Function
- SDI Audio Extract MegaCore Function
- Clocked Audio Input MegaCore Function
- Clocked Audio Output MegaCore Function

You can instantiate the SDI Audio with the SDI MegaCore function, and configure each SDI Audio core at run time using an Avalon-MM slave interface.

SDI Audio Embed MegaCore Function

The SDI Audio Embed MegaCore function embeds audio into the SD-, HD-, and 3G-SDI video standards. The format of the embedded audio is in accordance with the SMPTE272M standard for the SD-SDI video standard, or in accordance with the SMPTE299M standard for HD-SDI and provisionally for 3G-SDI video standard. This MegaCore function supports AES audio format for 48-kHz sampling rate.

The SDI Audio Embed MegaCore function embeds up to 16 channels or 8 channel pairs. The input audio can be any of the sample rates permitted by the SMPTE272M-A and SMPTE299M standards; synchronous to the video. If you want to embed audio pairs together in a sample audio group, the audio pairs must be synchronous with each other.

Functional Description

Figure 4-1 shows a block diagram of the SDI Audio Embed MegaCore function.

Figure 4-1. SDI Audio Embed MegaCore Function Block Diagram

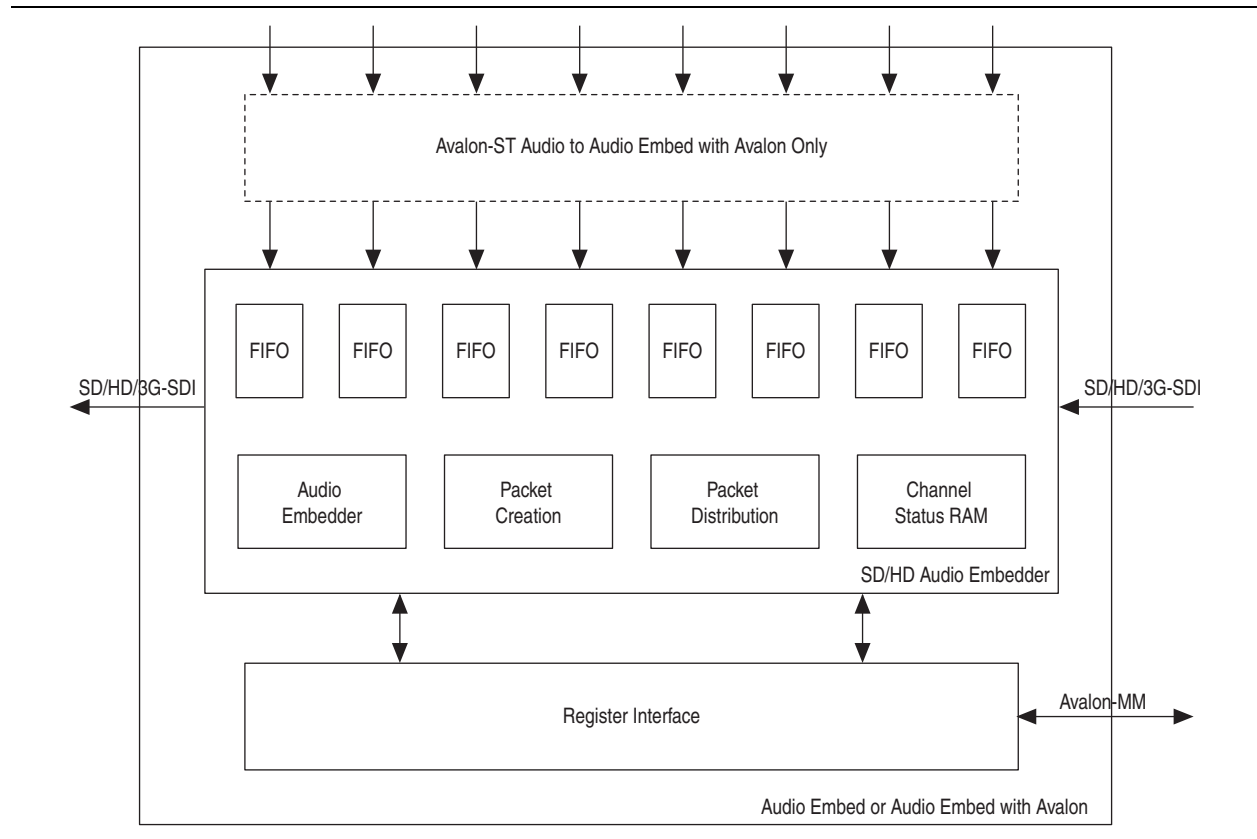

The SDI Audio Embed MegaCore function consists of an encrypted audio embedder core and a register interface block that provides support for an Avalon-MM control bus.

The audio embedder accepts the audio in AES format, and stores each channel pair in an input FIFO buffer. As the embedder places the audio sample in the FIFO buffer, it also records and stores the video clock phase information.

When accepting the audio in AES format, the SDI Audio Embed MegaCore function either maintains the channel-status details or replaces the details with the default or the RAM versions.

Parameters

Table 4-1 lists the parameters for the SDI Audio Embed MegaCore function.

Table 4-1. SDI Audio Embed MegaCore Function Parameters

Parameter	Value	Description
Number of supported audio groups	1, 2, 3, 4	Specifies the maximum number of audio groups supported. Each audio group consists of 4 audio channels (2 channel pairs). You must specify all the four channels to the same sample frequencies.
Async Audio Interface	On or Off	Turn on to enable the Asynchronous input. In this mode, the audio clock provides higher than 64* sample rate.
Frequency of fix_clk	0, 24.576, 25, 50, 100, 200	Specifies the frequency of the fix_clk signal.
Channel status RAM	0, 1, 2	Enables storage of the custom channel status data. Select 1 to generate a single channel status RAM, or 2 to generate separate RAMs for each input audio pair.
Frequency sine wave generator	On or Off	Turn on to enable a four-frequency sine wave generator. You can use the four-frequency sine wave generator as a test source for the audio embedder.
Include clock	On or Off	Turn on to enable a 48-kHz pulse generator synchronous to the video clock. You can use the 48-kHz pulse generator to request data from a sample rate convertor. When you turn on the Frequency Sine Wave Generator parameter, the core automatically includes this pulse generator.
Include Avalon-ST interface	On or Off	Turn on to include the SDI Clocked Audio Output MegaCore. When you turn on this parameter, the Avalon-ST interface signals in Table 4-14 appear at the top level. Otherwise, the audio input signals in Table 4-4 appear at the top level.
Include Avalon-MM control interface	On or Off	Turn on to include the Avalon-MM control interface. When you turn on this parameter, the register interface signals in Table 4-7 appear at the top level. Otherwise, the direct control interface signals in Table 4-6 appear at the top level.

Signals

Table 4–2 lists the general input and output signals for the SDI Audio Embed MegaCore function.

Table 4–2. General Input and Output Signals

Signal	Width	Direction	Description
reset	[0:0]	Input	This signal resets the system.
fix_clk	[0:0]	Input	This signal provides the frequency reference used when detecting the difference between video standards using 1 and 1/1.001 clock rates. If its frequency is 0, the signal only detects either one of the clock rates. The core limits the possible frequencies for this signal to 24.576 MHz, 25 MHz, 50 MHz, 100 MHz, and 200 MHz. Set the required frequency using the Frequency of fix_clk parameter.
vid_std_rate	[0:0]	Input	If you set the Frequency of fix_clk parameter to 0, you must drive this signal high to detect a video frame rate of 1/1.001 and low to detect a video frame rate of 1. For other settings of the Frequency of fix_clk parameter, the core automatically detects these frame rates and drives this signal low.
vid_clk48	[0:0]	Output	The 48 kHz output clock that is synchronous to the video. This clock signal is only available when you turn on the Frequency Sine Wave Generator or Include Clock parameter.

Table 4–3 lists the video input and output signals for the SDI Audio Embed MegaCore function.

Table 4–3. Video Input and Output Signals (Part 1 of 2)

Signal	Bits	Direction	Description
vid_clk	[0:0]	Input	The video clock that is typically 27 MHz for SD-SDI, 74.25 MHz or 74.17 MHz for HD-SDI, or 148.5 MHz or 148.35 MHz for 3G-SDI standards. You can use higher clock rates with the vid_datavalid signal.
vid_std	[1:0]	Input	Set this signal to indicate the following formats: <ul style="list-style-type: none"> ■ [00] for 10-bit SD-SDI ■ [01] for 20-bit HD-SDI ■ [10] for 3G-SDI Level B ■ [11] for 3G-SDI Level A
vid_datavalid	[0:0]	Input	Assert this signal when the video data is valid.

Table 4-3. Video Input and Output Signals (Part 2 of 2)

Signal	Bits	Direction	Description
vid_data	[19:0]	Input	This signal carries luma and chroma information. This signal carries luma and chroma information. SD-SDI: <ul style="list-style-type: none"> ■ [19:10] Unused ■ [9:0] Cb, Y, Cr, Y multiplex HD-SDI and 3G-SDI Level A: <ul style="list-style-type: none"> ■ [19:10] Y ■ [9:0] C 3G-SDI Level B: <ul style="list-style-type: none"> ■ [19:10] Cb, Y, Cr, Y multiplex (link A) ■ [9:0] Cb, Y, Cr, Y multiplex (link B)
vid_out_datavalid	[0:0]	Output	The core drives this signal high during valid output video clock cycles.
vid_out_trsr	[0:0]	Output	The core drives this signal high during the first 3FF clock cycle of a video timing reference signal; the first two 3FF cycles for 3G-SDI Level B. This signal provides easy connection to the Altera SDI MegaCore function.
vid_out_ln	[10:0]	Output	The video line signal that provides for easy connection to the Altera SDI MegaCore function.
vid_out_data	[19:0]	Output	The video output signal.

Table 4-4 lists the audio input signals for the SDI Audio Embed MegaCore function.

Table 4-4. Audio Input Signals

Signal	Width	Direction	Description
aud_clk	[2N-1:0]	Input	Set this clock to 3.072 MHz that is synchronous to the extracted audio. In asynchronous mode, set this to any frequency above 3.072 MHz. Altera recommends that you set this clock to 50 MHz. For SD-SDI inputs, this mode of operation limits the core to extracting audio that is synchronous to the video. For HD-SDI inputs, this clock must either be generated from the optional 48 Hz output or the audio must be synchronous to the video.
aud_de	[2N-1:0]	Input	Assert this data enable signal to indicate valid information on the aud_ws and aud_data signals. In synchronous mode, the core ignores this signal.
aud_ws	[2N-1:0]	Input	Assert this word select signal to provide framing for deserialization and to indicate left or right sample of channel pair.
aud_data	[2N-1:0]	Input	Internal AES data signal from the AES input module. Refer to Figure 4-9.

Note to Table 4-4:

(1) N represents the number of audio groups.

Table 4-5 lists the Avalon-ST audio signals when you instantiate the SDI Audio Embed MegaCore function in SOPC Builder.

Table 4-5. Avalon-ST Audio Signals for SDI Audio Embed MegaCore Function

Signal	Width	Direction	Description
aud(n)_clk	[0:0]	Input	Clocked audio clock. All the audio input signals are synchronous to this clock.
aud(n)_ready	[0:0]	Output	Avalon-ST ready signal. Assert this signal when the device is able to receive data.
aud(n)_valid	[0:0]	Input	Avalon-ST valid signal. The MegaCore function asserts this signal when it receives data.
aud(n)_sop	[0:0]	Input	Avalon-ST start of packet signal. The MegaCore function asserts this signal when it is starting a new frame.
aud(n)_eop	[0:0]	Input	Avalon-ST end of packet signal. The MegaCore function asserts this signal when it is ending a frame.
aud(n)_channel	[7:0]	Input	Avalon-ST select signal. Use this signal to select a specific channel.
aud(n)_data	[23:0]	Input	Avalon-ST data bus. This bus transfers data.

Note to Table 4-5:

(1) (n) represents the channel number.

Table 4-6 lists the direct control interface signals. These signals are exposed as ports if you turn off the **Include Avalon-MM Control Interface** parameter.

Table 4-6. Direct Control Interface Signals (Part 1 of 2)

Signal	Width	Direction	Description
reg_clk	[0:0]	Input	Clock for the direct control interface.
audio_control	[7:0]	Input	This signal does the same function as the audio control register in Table 4-9.
extended_control	[7:0]	Input	This signal does the same function as the extended control register in Table 4-9.
video_status	[7:0]	Output	This signal does the same function as the video status register in Table 4-9.
audio_status	[7:0]	Output	This signal does the same function as the audio status register in Table 4-9.
cs_control	[15:0]	Input	This signal does the same function as the channel status control registers in Table 4-9.
sine_freq_ch1	[7:0]	Input	This signal does the same function as the sine channel 1 frequency register in Table 4-9.
sine_freq_ch2	[7:0]	Input	This signal does the same function as the sine channel 2 frequency register in Table 4-9.
sine_freq_ch3	[7:0]	Input	This signal does the same function as the sine channel 3 frequency register in Table 4-9.
sine_freq_ch4	[7:0]	Input	This signal does the same function as the sine channel 4 frequency register in Table 4-9.
csram_addr	[5:0]	Input	Channel status RAM address.

Table 4–6. Direct Control Interface Signals (Part 2 of 2)

Signal	Width	Direction	Description
csram_we	[0:0]	Input	Drive this signal high for a single cycle of reg_clk signal to load the value of the csram_data port into the channel status RAM at the address on the csram_addr port. If each input audio pair gets separate channel status RAMs, this signal addresses the RAM selected by the extended_control port.
csram_data	[7:0]	Input	Channel status data. This signal does the same function as the channel status RAM register in Table 4–9.

Table 4–7 lists the register interface signals. The register interface is a standard 8-bit wide Avalon-MM slave.

Table 4–7. Register Interface Signals

Signal	Width	Direction	Description
reg_clk	[0:0]	Input	Clock for the Avalon-MM register interface.
reg_reset	[0:0]	Input	Reset for the Avalon-MM register interface.
reg_base_addr	[5:0]	Input	Address in target region of first byte of transfer
reg_burst_count	[5:0]	Input	Transfer size in bytes
reg_waitrequest	[0:0]	Output	Wait request
reg_write	[0:0]	Input	Write request
reg_writedata	[7:0]	Input	Data to be written to target
reg_read	[0:0]	Input	Read request
reg_readdatavalid	[0:0]	Output	Requested read data valid after read latency
reg_readdata	[7:0]	Output	Data read from target

Register Maps

Table 4–8 and Table 4–9 lists the register maps for SDI Audio Embed MegaCore function.

Table 4–8. SDI Audio Embed MegaCore Function Register Map

Bytes Offset	Name
00h	Audio Control Register
01h	Extended Control Register
02h	Video Status Register
03h	Audio Status Register
04h	Channel Status Control Registers (3:0)
05h	Channel Status Control Registers (7:4)
06h–07h	Reserved
08h	Sine Channel 1 Frequency
09h	Sine Channel 2 Frequency
0Ah	Sine Channel 3 Frequency
0Bh	Sine Channel 4 Frequency
0Ch–0Fh	Reserved
10h–3Fh	Channel Status RAM (0x00), (0x01), ... (0x2F)

Table 4–9. SDI Audio Embed MegaCore Function Register Map

Bit	Name	Access	Description
Audio Control Register			
3:0	Audio group enable	RW	Enables the embedding of each audio group. When working with HD-SDI or 3G-SDI video, embedding of the audio control packet is also enabled when one or more audio groups are enabled. The following bits correspond to the number of audio groups you specify: <ul style="list-style-type: none"> ■ Bit [0] = Audio group 1 ■ Bit [1] = Audio group 2 ■ Bit [2] = Audio group 3 ■ Bit [3] = Audio group 4
7:4	Unused	—	Reserved for future use.
Extended Control Register			
2:0	Channel status RAM select	RW	When you specify the Channel Status RAM parameter to 2 , this field selects the channel pair for the RAM written to by registers 10h to 3Fh. If you specify the Channel Status RAM parameter to 0 or 1 , ignore this signal.
3	Unused	—	Reserved for future use.
4	Test sine generator enable	RW	When set to 1b , this bit ignores the audio inputs and uses the output of the sine generator as the data for each audio group.
7:5	Unused	—	Reserved for future use.

Table 4-9. SDI Audio Embed MegaCore Function Register Map

Bit	Name	Access	Description
Video Status Register			
7:0	Active channels	RO	<p>Reports the detected video input standard.</p> <p>Bits[7:5] = Picture structure code.</p> <p>Defined values for picture structure code are:</p> <p>001b = 486 or 576 line SD-SDI</p> <p>100b = 720 line HD-SDI</p> <p>101b = 1080 line HD-SDI</p> <p>010b = 1080 line 3G-SDI</p> <p>Bit[4] = 0b—Interlace or segmented frame, 1b—Progressive.</p> <p>Bits[3:0] = Frame rate code.</p> <p>Defined values for frame rate code (in Hz) are:</p> <p>0010b = 23.97</p> <p>0011b = 24</p> <p>0101b = 25</p> <p>0110b = 29.97</p> <p>0111b = 30</p> <p>1001b = 50</p> <p>1010b = 59.94</p> <p>1011b = 60</p>
Audio Status Register			
7:0	Unused	—	Reserved for future use.
Channel Status Control Registers			
7:0	CS mode select	RW	<p>When set to 00b, the core keeps the existing channel status data.</p> <p>When set to 01b, the core replaces the channel status data with default values.</p> <p>When set to 10b, the core replaces the data with the contents of the appropriate channel status RAM.</p> <p>The following bits correspond to the number of audio groups you specify:</p> <ul style="list-style-type: none"> ■ Bit [1:0] = Audio group 1 ■ Bit [3:2] = Audio group 2 ■ Bit [5:4] = Audio group 3 ■ Bit [7:6] = Audio group 4
Sine Channel <i>n</i> Frequency			
7:0	Sine channel frequency	RW	Defines the frequency of the generated audio.
Channel Status RAM			
7:0	Channel status data	WO	Write accesses within the address range 10h to 3Fh to the channel status RAM. This field returns the 24 bytes of channel status for X channels starting at address 10h to 27h, and the 24 bytes of channel status for Y channels starting at address 28h to 3Fh.

SDI Audio Extract MegaCore Function

The SDI Audio Extract MegaCore function accepts the SD-, HD-, and 3G-SDI from the SDI MegaCore and extracts one channel pair of embedded audio.

The format of the embedded audio is in accordance with the SMPTE272M-A standard for the SD-SDI video standard, or in accordance with the SMPTE299M standard for HD-SDI and provisionally for 3G-SDI video standard. If you are extracting more than one channel pair, you must use multiple instances of the component. This MegaCore function supports AES audio format for 48-kHz sampling rate.

Functional Description

Figure 4-2 shows a block diagram of the SDI Audio Extract MegaCore function.

Figure 4-2. SDI Audio Extract MegaCore Function Block Diagram

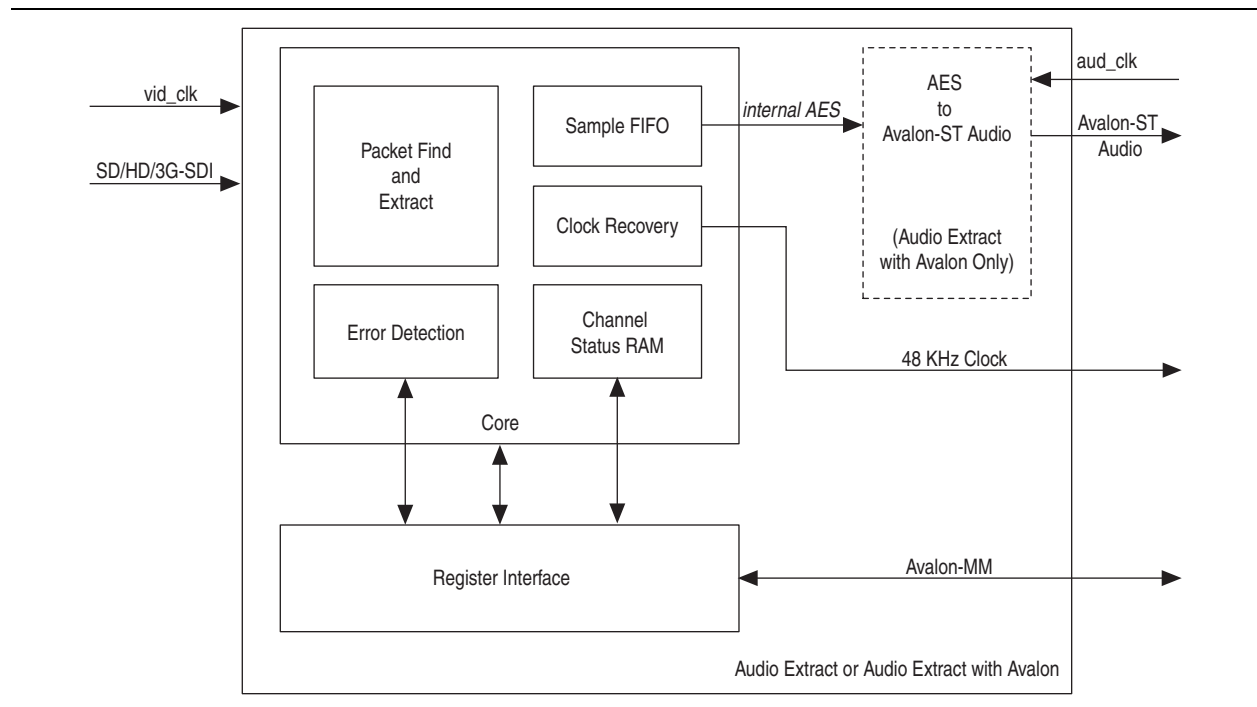

The SDI Audio Extract MegaCore function consists of the audio extraction core and a register interface block that provides support for an Avalon-MM control bus.

The clock recovery block recreates a $64 \times$ sample rate clock, which you can use to clock the audio output logic. As the component recreates this clock from a 200-MHz reference clock, the created clock may have a higher jitter than is desirable.

A digital PLL synchronizes this created clock to a 24-kHz reference source. For the HD-SDI embedded audio, the 24-kHz reference source is the embedded clock phase information. For the SD-SDI embedded audio, where the embedded clock phase data is not present, you can create the 24-kHz reference signal directly from the video clock.

Figure 4-3 shows the clock recovery block diagram.

Figure 4-3. Clock Recovery Block Diagram

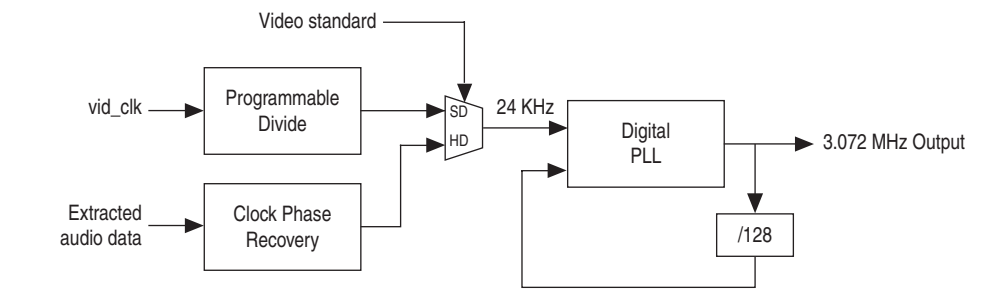

Parameters

Table 4-10 lists the parameters for the SDI Audio Extract MegaCore function.

Table 4-10. SDI Audio Extract MegaCore Function Parameters

Parameter	Value	Description
Channel status RAM	On or off	Turn on to store the received channel status data.
Include error checking	On or off	Turn on to enable extra error-checking logic to use the error status register.
Include status register	On or off	Turn on to enable extra logic to report the audio FIFO status on the <code>fifo_status</code> port or register.
Include clock	On or off	Turn on to enable the logic to recover both a sample rate clock and a $64 \times$ sample rate clock. With HD-SDI inputs, the core generates the output by using the embedded clock phase information. With SD-SDI inputs, the core generates this output by using the counters running on the 27MHz video clock. This generation limits the SD-SDI embedded audio to being synchronous to the video.
Include Avalon-ST interface	On or off	Turn on to include the SDI Clocked Audio Input MegaCore. When you turn on this parameter, the Avalon-ST interface signals in Table 4-14 appear at the top level. Otherwise, the audio input signals in Table 4-17 appear at the top level.
Include Avalon-MM control interface	On or off	Turn on to include the Avalon-MM control interface. When you turn on this parameter, the register interface signals in Table 4-7 appear at the top level. Otherwise, the direct control interface signals in Table 4-15 appear at the top level.

Signals

Table 4–11 lists the clock recovery input and output signals for the SDI Audio Extract MegaCore function.

Table 4–11. Clock Recovery Input and Output Signals

Signal	Width	Direction	Description
reset	[0:0]	Input	This signal resets the system.
fix_clk	[0:0]	Input	Assert this 200 MHz reference clock when you turn on the Include Clock parameter.
aud_clk_out	[0:0]	Output	The core asserts this 64 × sample rate clock (3.072 MHz audio clock) when you turn on the Include Clock parameter. You use this clock to clock the audio interface in synchronous mode. As the core creates this clock digitally, it is prone to higher levels of jitter.
aud_clk48_out	[0:0]	Output	The core asserts this sample rate clock when you turn on the Include Clock parameter.

Table 4–12 shows the video input signals for the SDI Audio Extract MegaCore function.

Table 4–12. Video Input Signals

Signal	Width	Direction	Description
vid_clk	[0:0]	Input	The video clock that is typically 27 MHz for SD-SDI, 74.25 MHz or 74.17 MHz for HD-SDI, or 148.5 MHz or 148.35 MHz for 3G-SDI standards. You can use higher clock rates with the <code>vid_datavalid</code> signal.
vid_std	[1:0]	Input	Set this signal to <code>00b</code> to indicate 10-bit SD-SDI formats, <code>01b</code> for 20-bit HD-SDI formats, <code>11b</code> for 3G Level A formats, and <code>10b</code> for 3G-SDI Level B formats.
vid_datavalid	[0:0]	Input	Assert this signal when the video data is valid.
vid_data	[19:0]	Input	This signal carries luma and chroma information. SD-SDI: <ul style="list-style-type: none"> ■ [19:10] Unused ■ [9:0] Cb,Y, Cr, Y multiplex HD-SDI and 3G-SDI Level A: <ul style="list-style-type: none"> ■ [19:10] Y ■ [9:0] C 3G-SDI Level B: <ul style="list-style-type: none"> ■ [19:10] Cb,Y, Cr, Y multiplex (link A) ■ [9:0] Cb,Y, Cr, Y multiplex (link B)
vid_locked	[0:0]	Input	Assert this signal when the video is locked.

Table 4-13 lists the audio input and output signals for the SDI Audio Extract MegaCore function.

Table 4-13. Audio Input and Output Signals

Signal	Width	Direction	Description
aud_clk	[0:0]	Input	Set this clock to 3.072 MHz that is synchronous to the extracted audio. For SD-SDI inputs, this mode of operation limits the core to extracting audio that is synchronous to the video. For HD-SDI inputs, you must generate this clock from the optional 48 kHz output or the audio must be synchronous to the video.
aud_ws_in	[0:0]	Input	Some audio receivers provide a word select output to align the serial outputs of several audio extract cores. In these circumstances, assert this signal to control the output timing of the audio extract externally, otherwise set it to 0. This signal must be a repeating cycle of high for 32 aud_clk cycles followed by low for 32 aud_clk cycles.
aud_de	[0:0]	Output	The core asserts this data enable signal to indicate valid information on the aud_ws and aud_data signals. In synchronous mode, the core drives this signal high.
aud_ws	[0:0]	Output	The core asserts this word select signal to provide framing for deserialization and to indicate left or right sample of channel pair.
aud_data	[0:0]	Output	The core asserts this signal to extract the internal AES audio signal from the AES output module. Refer to Figure 4-9.

Table 4-14 lists the Avalon-ST audio signals when you instantiate the SDI Audio Extract MegaCore function in SOPC Builder.

Table 4-14. Avalon-ST Audio Signals for SDI Audio Extract MegaCore Function

Signal	Width	Direction	Description
aud_clk	[0:0]	Input	Clocked audio clock. All the audio input signals are synchronous to this clock.
aud_ready	[0:0]	Input	Avalon-ST ready signal. Assert this signal when the device is able to receive data.
aud_valid	[0:0]	Output	Avalon-ST valid signal. The MegaCore function asserts this signal when it outputs data.
aud_sop	[0:0]	Output	Avalon-ST start of packet signal. The MegaCore function asserts this signal when a frame starts.
aud_eop	[0:0]	Output	Avalon-ST end of packet signal. The MegaCore function asserts this signal when a frame ends.
aud_channel	[7:0]	Output	Avalon-ST select signal. This signal indicates which channel is selected.
aud_data	[23:0]	Output	Avalon-ST data bus. This bus transfers data.

Table 4-15 shows the direct control interface signals. The direct control interface is internal to the audio extract component.

Table 4-15. Direct Control Interface Signals

Signal	Width	Direction	Description
reg_clk	[0:0]	Input	Clock for direct control interface signals.
audio_control	[7:0]	Input	This signal does the same function as the audio control register in Table 4-17.
audio_presence	[7:0]	Output	This signal does the same function as the audio presence register in Table 4-17.
audio_status	[7:0]	Output	This signal does the same function as the audio status register in Table 4-17.
error_status	[7:0]	Output	This signal does the same function as the error status register in Table 4-17.
error_reset	[7:0]	Input	Set any bit of this port high for a single cycle of reg_clk to clear the corresponding bit of the error_status signal. Setting any of bits [3:0] high for a clock cycle resets the entire 4-bit error counter.
fifo_status	[7:0]	Output	This signal does the same function as the FIFO status register in Table 4-17.
fifo_reset	[0:0]	Input	Set high for a single cycle of reg_clk to clear the underflow or overflow field of the fifo_status signal.
clock_status	[7:0]	Output	This signal does the same function as the clock status register in Table 4-17.
csram_addr	[5:0]	Input	Channel status RAM address. The contents of the selected address will be valid on the csram_data signal after one cycle of reg_clk.
csram_data	[7:0]	Output	Channel status data. This signal does the same function as the channel status RAM in Table 4-17.

Register Maps

Table 4-16 and Table 4-17 list the register maps for SDI Audio Extract MegaCore function.

Table 4-16. SDI Audio Extract MegaCore Function Register Map

Bytes Offset	Name
00h	Audio Control Register
01h	Audio Presence Register
02h	Audio Status Register
03h	Reserved
04h	Error Status Register
05h	Reserved
06h	FIFO Status Register
07h	Clock Status Register
08h-09h	Reserved
10h-3Fh	Channel Status RAM (0x00), (0x01), ... (0x2F)

Table 4-17. SDI Audio Extract MegaCore Function Register Map (Part 1 of 2)

Bit	Name	Access	Description
Audio Control Register			
0	Enable	RW	Enables the audio extraction component and internal AES output.
3:1	Extract pair	RW	Defines the audio pair that the component extracts. For example: <ul style="list-style-type: none"> ■ [000] = Extract the first channel pair of audio signal ■ [111] = Extract the eighth channel pair of audio signal
4	Extract pair MSB	RW	For 3G-SDI Level A standard, this field extends the extract pair field to allow for future implementations with 32 embedded audio channels. For 3G-SDI Level B standard, this field selects the active video half of the 3G multiplex.
5	Mute	RW	Drive this register high to mute the audio output.
7:6	Unused	—	Reserved for future use.
Audio Presence Register			
3:0	Data packet present	RO	Reports which audio data groups are detected in the SDI stream. The following bits correspond to the number of audio groups detected: <ul style="list-style-type: none"> ■ Bit [0] = Audio group 1 ■ Bit [1] = Audio group 2 ■ Bit [2] = Audio group 3 ■ Bit [3] = Audio group 4
7:4	Control packet present	RO	Reports which audio control packets are detected in the SDI stream.
Audio Status Register			
3:0	Active channels	RW	Reflects the lower four bits of the ACT (active) field of the audio control packet.

Table 4-17. SDI Audio Extract MegaCore Function Register Map (Part 2 of 2)

Bit	Name	Access	Description
4	Asynchronous	RW	Reflects the asx bit of the RATE (sampling rate) field of the audio control packet.
6:5	Sample rate	RW	Reports the X1 and X0 bits of the sample rate code from the RATE field of the audio control packet.
7	Status valid	RW	Set to 1b when the audio control packet is present in the video stream.
Error Status Register			
3:0	Error counter	RW	Counts up to 15 errors since last reset. Write 1b to any bit of this field to reset the entire counter to zero.
4	Ancillary CS fail	RW	Indicates that an error has been detected in the ancillary packet checksum. This bit stays set until cleared by writing 1b to this register.
5	Ancillary parity fail	RW	Indicates that an error has been detected in at least one of the parity fields: the ancillary packet parity bit, the audio sample parity bit (for SD-SDI) or the AES sample parity bit (for HD-SDI). This bit stays set until cleared by writing 1b to this register.
6	Channel status CRC fail	RW	Indicates that an error has been detected in the channel status CRC. This bit stays set until cleared by writing 1b to this register.
7	Audio packet ECRC fail	RW	Indicates that an error has been detected in the ECRC that forms part of the HD audio data packet. This bit stays set until cleared by writing 1b to this register.
FIFO Status Register			
6:0	FIFO fill level	RO	Reports the amount of data in either the audio output FIFO or the Avalon-ST audio FIFO when the optional Avalon-ST Audio interface is used.
7	Overflow/Underflow	RW	This register bit goes high if there is either underflow/overflow of the audio output FIFO or the overflow of the Avalon-ST audio FIFO, depending on the output mode used. This register always goes high at the beginning, so you must clear the audio FIFO first for the register to indicate underflow or overflow.
Clock Status Register			
4:0	Offset	RO	Returns the current status of the digital PLL used to create the output $64 \times$ sample rate clock.
6:5	Unused	—	Reserved for future use.
7	74.17-MHz video clock	RO	To create a 48-kHz signal synchronous to the video clock, you must detect whether a 1 or 1/1.001 video clock rate is used. If you detect a 1/1.001 video clock rate, this field returns high.
Channel Status RAM			
7:0	Channel status data	WO	Read accesses within the address range 10h to 3Fh to the channel status RAM. This field returns the 24 bytes of channel status for X channel starting at address 10h and the 24 bytes of channel status for Y channel starting at address 28h.

For register interface signals, refer to [Table 4-7 on page 4-7](#). All SDI audio cores use the same register interface signals.

Clocked Audio Input MegaCore Function

The Clocked Audio Input MegaCore function converts clocked audio in AES formats to Avalon-ST audio.

For a typical AES input, for each channel, the Clocked Audio Input function creates a 192-bit validity word, user word and channel status word, and presents the words as a control packet after the audio data packet.

Parameters

Table 4-18 lists the MegaWizard Plug-In Manager parameters for the SDI Clocked Audio Input MegaCore function.

Table 4-18. SDI Clocked Audio Input MegaCore Function Parameters

Parameter	Value	Description
FIFO size	3-10	Defines the internal FIFO depth. For example, a value of 3 means $2^3 = 8$.
Include Avalon-MM control interface	On or off	Turn on to include the Avalon-MM control interface. When you turn on this parameter, the register interface signals in Table 4-7 appear at the top level. Otherwise, the direct control interface signals in Table 4-21 appear at the top level.

Signals

Table 4-19 lists the Avalon-ST audio signals when you instantiate the SDI Clocked Audio Input MegaCore function in SOPC Builder.

Table 4-19. Audio Input Signals

Signal	Width	Direction	Description
aes_clk	[0:0]	Input	Audio input clock.
aes_de	[0:0]	Input	Audio data enable.
aes_ws	[0:0]	Input	Audio word select.
aes_data	[0:0]	Input	Audio data input in internal AES format.

Table 4-20 lists the Avalon-ST audio signals when you instantiate the SDI Clocked Audio Input MegaCore function in SOPC Builder.

Table 4-20. Avalon-ST Audio Signals (Part 1 of 2)

Signal	Width	Direction	Description
aud_clk	[0:0]	Input	Clocked audio clock. All the audio input signals are synchronous to this clock.
aud_ready	[0:0]	Input	Avalon-ST ready signal. Assert this signal when the device is able to receive data.
aud_valid	[0:0]	Output	Avalon-ST valid signal. The MegaCore function asserts this signal when it is outputs data.

Table 4-20. Avalon-ST Audio Signals (Part 2 of 2)

Signal	Width	Direction	Description
aud_sop	[0:0]	Output	Avalon-ST start of packet signal. The MegaCore function asserts this signal when it is starting a new frame.
aud_eop	[0:0]	Output	Avalon-ST end of packet signal. The MegaCore function asserts this signal when it is ending a frame.
aud_data	[23:0]	Output	Avalon-ST data bus. The MegaCore function asserts this signal to transfer data.

Table 4-21 lists the direct control interface signals. The direct control interface is internal to the audio extract component.

Table 4-21. Direct Control Interface Signals

Signal	Width	Direction	Description
channel0	[7:0]	Input	Indicates the channel number of audio channel 1.
channel1	[7:0]	Input	Indicates the channel number of audio channel 2.
fifo_reset	[7:0]	Input	Drive bit 7 high to reset the clocked audio input FIFO buffer.
fifo_status	[0:0]	Output	Assert this signal when the clocked audio input FIFO buffer overflows.

For register interface signals, refer to Table 4-7. All SDI audio cores use the same register interface signals.

Register Maps

Table 4-22 and Table 4-23 list the register maps for the SDI Clocked Audio Input MegaCore function.

Table 4-22. SDI Clocked Audio Input MegaCore Function Register Map

Bytes Offset	Name
00h	Channel 0 Register
01h	Channel 1 Register
02h	FIFO Status Register
03h	FIFO Reset Register

Table 4-23. SDI Clocked Audio Input MegaCore Function Register Map (Part 1 of 2)

Bit	Name	Access	Description
Channel 0 Register			
7:0	Channel 0	RW	The user-defined channel number of audio channel 0.
Channel 1 Register			
7:0	Channel 1	RW	The user-defined channel number of audio channel 1.
FIFO Status Register			
7:0	FIFO status	RO	This sticky bit reports the overflow of the clocked audio input FIFO.

Table 4-23. SDI Clocked Audio Input MegaCore Function Register Map (Part 2 of 2)

Bit	Name	Access	Description
FIFO Reset Register			
6:0	Unused	WO	Reserved.
7	FIFO reset	WO	Resets the clocked audio FIFO.

Clocked Audio Output MegaCore Function

The Clocked Audio Output MegaCore function accepts clocked Avalon-ST audio and converts to audio in modified AES formats.

Parameters

Table 4-24 lists the MegaWizard Plug-In Manager parameters for the SDI Clocked Audio Output MegaCore function.

Table 4-24. SDI Clocked Audio Output MegaCore Function Parameters

Parameter	Value	Description
FIFO size	3-10	Defines the internal FIFO depth. For example, a value of 3 means $2^3 = 8$.
Include Avalon-MM control interface	On or Off	Turn on to include the Avalon-MM control interface. When you turn on this parameter, the register interface signals in Table 4-7 appear at the top level. Otherwise, the direct control interface signals in Table 4-6 appear at the top level.

Signals

Table 4-25 lists the Avalon-ST audio input and output signals when you instantiate the SDI Clocked Audio Output MegaCore function in SOPC Builder.

Table 4-25. Audio Input and Output Signals

Signal	Width	Direction	Description
aes_clk	[0:0]	Input	Audio input clock.
aes_de	[0:0]	Output	Audio data enable.
aes_ws	[0:0]	Output	Audio word select.
aes_data	[0:0]	Output	Audio data output in internal AES format.

Table 4-26 lists the Avalon-ST audio signals when you instantiate the SDI Clocked Audio Output MegaCore function in SOPC Builder.

Table 4-26. Avalon-ST Audio Signals (Part 1 of 2)

Signal	Bits	Direction	Description
aud_clk	[0:0]	Input	Clocked audio clock. All the audio input signals are synchronous to this clock.
aud_ready	[0:0]	Output	Avalon-ST ready signal. Assert this signal when the device is able to receive data.

Table 4–26. Avalon-ST Audio Signals (Part 2 of 2)

Signal	Bits	Direction	Description
aud_valid	[0:0]	Input	Avalon-ST valid signal. The MegaCore function asserts this signal when it receives data.
aud_sop	[0:0]	Input	Avalon-ST start of packet signal. The MegaCore function asserts this signal when it is starting a new frame.
aud_eop	[0:0]	Input	Avalon-ST end of packet signal. The MegaCore function asserts this signal when it is ending a frame.
aud_data	[23:0]	Input	Avalon-ST data bus. This bus transfers data.

For register interface signals, refer to [Table 4–7](#). All SDI audio cores use the same register interface signals.

Register Maps

[Table 4–27](#) and [Table 4–28](#) list the register maps for the SDI Clocked Audio Output MegaCore function.

Table 4–27. SDI Clocked Audio Output MegaCore Function Register Map

Bytes Offset	Name
00h	Channel 0 Register
01h	Channel 1 Register
02h	FIFO Status Register
03h	FIFO Reset Register

Table 4–28. SDI Clocked Audio Output MegaCore Function Register Map

Bit	Name	Access	Description
Channel 0 Register			
7:0	Channel 0	RW	The user-defined channel number of audio channel 0.
Channel 1 Register			
7:0	Channel 1	RW	The user-defined channel number of audio channel 1.
FIFO Status Register			
7:0	FIFO status	RO	This sticky bit reports the overflow of the clocked audio output FIFO.
FIFO Reset Register			
6:0	Unused	WO	Reserved.
7	FIFO reset	WO	Resets the clocked audio FIFO.

AES Format

The SDI cores use the AES standard. The Audio Engineering Society (AES), together with the European Broadcasting Union (EBU), created a digital audio transmission standard known as the AES/EBU standard. The AES standard is a digital audio standard for transporting digital audio signals serially between devices.

Using the AES format requires the entire 64-bit AES frame to be sent serially. As the AES defines the preambles as biphasic mark codes, which cannot be directly decoded to 4 bits, you must replace the preambles with $X = 0000b$, $Y = 0001b$, and $Z = 0010b$. This internal AES format serializes the bit-parallel data words by sending the least significant bits (LSB) first, with the audio sample (up to 24 bits).

Figure 4-4 shows the timing diagram of the internal AES format.

Figure 4-4. Internal AES Format Timing Diagram

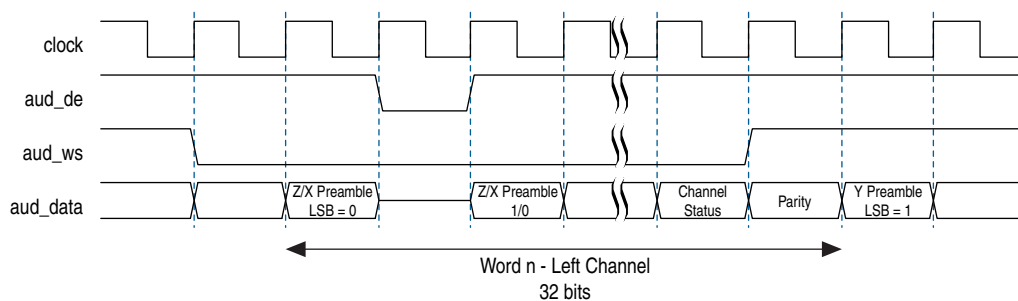

Avalon-ST Audio Interface

To allow the standard components inside SOPC Builder to interconnect, you must define the Avalon-ST audio interface. The Avalon-ST audio interface must carry audio to and from physical AES3 interfaces; which means to support the AES3 outputs, the interface must transport the extra V, U, and C bits. You may create the P bit.

Each audio block consists of 192 frames, and each frame has channels 1 and 2. Each frame has a combination of the bits shown in Figure 4-5.

Figure 4-5. AES Format

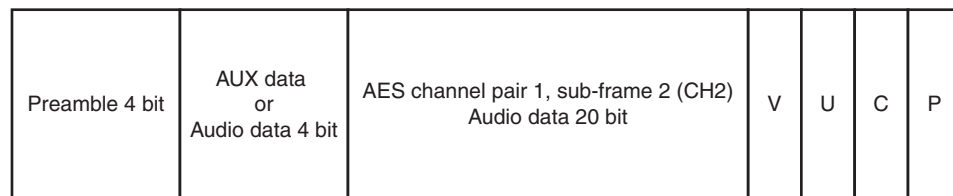

The Avalon-ST is a packet-based interface, which carries audio information as a sequence of data packets. The functions define the types of packets as audio data packets and audio control packets.

Figure 4-6 shows the audio data and audio control packets for Avalon-ST audio interface.

Figure 4-6. Audio Data and Audio Control Packets for Avalon-ST Audio Interface

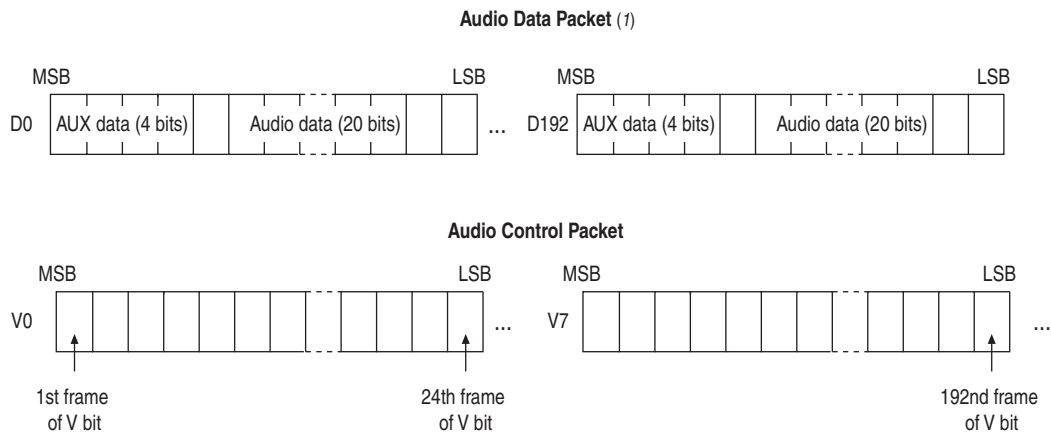

Note to Figure 4-6:

(1) The sequence of audio control packets begins with V bit, U bit, and finally C bit. The audio control packets for U and C bits are similar to V bits.

The Avalon-ST audio protocol separates the audio data from the control or status data to facilitate audio data processing. The protocol defines that the data is packed LSB first, which matches the AES3 data. The audio data size is configurable at compile time and matches the audio data sample size. Including the aux, the audio data word would be 24 bits.

In Avalon-ST audio, the data is packed as 24 bit symbols, typically with 1 symbol per beat [23:0]. The core transmits the audio control data as a packet after the audio data to meet the latency requirements.

The packet type identifier defines the packet type. The packet type identifier is the first value of any packet, when the start of packet signal is high. The audio data packet identifier is 0xA and the audio control data packet identifier is 0xE. Table 4-29 lists the packet types.

Table 4-29. Avalon-ST Packet Types

Type Identifier	Description
0	Video data packet
1-8	User packet types
10	Audio data packet
14	Audio control data packet
15	Video control data packet
9-15	Reserved

The preamble data, XYZ from AES, describes whether the data is at the start of a block and which channel the audio refers to. In Avalon-ST audio protocol, you are not required to transport the preamble data because the information stored in the data is described by the start of packet, end of packet, and channel signals.

The start of packet, end of packet, and channel signals indicate the start of the audio sample data and the associated audio channel.

For a single audio channel, the channel signal indicates channel 1 for all valid samples. [Figure 4-7](#) shows an example of a single audio channel.

Figure 4-7. Single Audio Channel

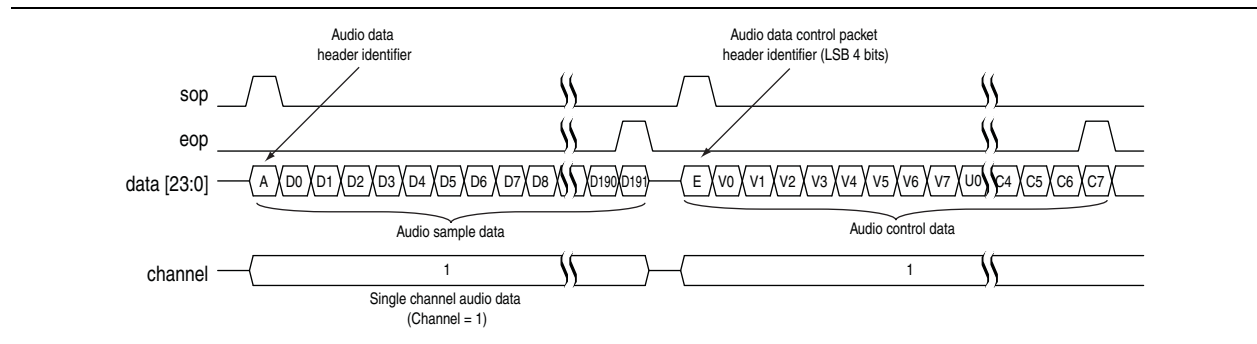

For multiple channels, the Avalon-ST interface standard allows the packets to interleave across the channels. By interleaving, the interface allows multiple audio sources to be multiplexed and demultiplexed.

[Figure 4-8](#) shows an example of two audio channels, where the channel signal indicates either channel 1 or channel 2. Each channel has a start of packet and an end of packet signal, which allows the channel interleaving and de-interleaving.

Figure 4-8. Multiple Audio Channel

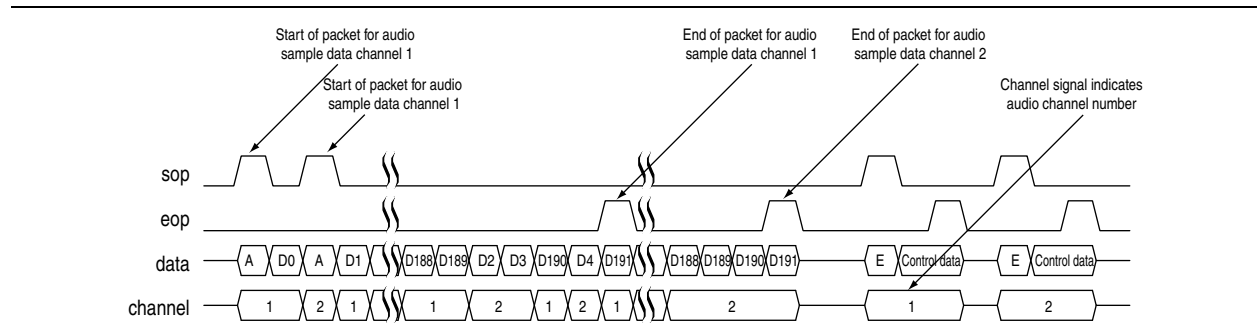

Instantiating the IP Cores

You can instantiate the SDI Audio Embed and Audio Extract MegaCore functions the following ways:

- Instantiates within SOPC Builder with audio inputs exposed outside SOPC Builder.
- Instantiate within SOPC Builder with audio inputs exposed as Avalon-ST Audio within SOPC Builder.
- Directly instantiate in RTL with a CPU register interface.
- Instantiate the encrypted core directly on RTL with control ports.

As the SDI Audio Embed and Audio Extract MegaCore functions use an Avalon-MM slave interface to access the control registers, the most convenient way for you to instantiate the components are within SOPC Builder. You are provided with the component declaration TCL files to support either the ordinary AES audio inputs or the Avalon-ST audio interface.

If you select a MegaCore function with ordinary audio interfaces within SOPC Builder, the audio interfaces are exposed for connection at the top level of the SOPC Builder design. Otherwise, the Avalon-ST audio interfaces are exposed within SOPC Builder for connection to other components.

Alternatively, you can also instantiate the SDI Audio Embed and Audio Extract MegaCore functions directly in your RTL and drive the direct control interface signals directly without the accompanying Avalon-MM register interface.

Simulating the Testbench

Altera provides a fixed testbench as an example to simulate the SDI Audio cores. You can obtain the testbench from `ip/altera/audio_embed/simulation` directory. To use the testbench with the ModelSim simulator, follow these steps:

1. Open the Quartus II software.
2. On the File menu, click the **New Project Wizard**.
3. Specify the working directory to `ip/altera/audio_embed/simulation/megacore_build`, and give a sensible name for your project and top-level entity.
4. Click **Next**, and select **Stratix IV** for the device family.
5. Click **Finish**.
6. On the Tools menu, click the **MegaWizard Plug-In Manager**.
7. Select **Edit an existing custom megafunction variation** and click **Next**.
8. Locate and click the `variant audio_embed_avalon_top.v` file and click **Next**.
9. In the SDI Audio Embed parameter editor, click **Finish** to regenerate the `variant audio_embed_avalon_top.v` file and produce the simulation model.
10. Repeat steps 6 to 9 for the remaining variant files provided in the `megacore_build` directory.
11. In a text editor, open the simulation script, `simulation/run.tcl`. Edit the script to point to your installation of the Quartus II software. For example:

```
set quartusdir /tools/acds/11.0/157/linux32/quartus/eda/sim_lib/
```
12. Start the ModelSim simulator.
13. Run `run.tcl` in the simulation directory. This file compiles the design. A selection of signals appears on the waveform viewer. The simulation runs automatically, providing a pass or fail indication upon completion.

Use this testbench to simulate the SDI Audio Embed MegaCore and the associated SDI Audio Extract MegaCore functions, and the SDI Clocked Audio Input MegaCore and the associated Clocked Audio Output MegaCore functions.

You can select the video standard for the video test source through the generic `G_TEST_STD` of the testbench entity which can be set to 0, 1, 2 or 3 to select SD-SDI, HD-SDI, 3G-SDI Level A, or 3G-SDI Level B respectively.

The audio test source uses the 48-kHz clock output from the SDI Audio Embed MegaCore function. The audio test sample comprises an increasing count which allows the testbench to check the extracted audio at the far end of the processing chain.

The SDI Audio Embed MegaCore function accepts these video and audio test sources to create a video stream with embedded audio. The SDI Audio Extract MegaCore function then receives the resulting stream to recover the embedded audio. You can examine this audio sequence to ensure that the count pattern that was created is preserved.

The synchronisation requirements of the receive FIFO buffer in the SDI Audio Extract MegaCore function allows you to repeat the occasional sample from the SDI Audio Extract MegaCore function. Synchronisation may take up to a field period of typically 16.7 ms to complete.

You can instantiate another SDI Audio Embed MegaCore function with Avalon-ST interface (with embedded clocked audio output component) and the associated SDI Audio Extract MegaCore function with Avalon-ST interface (with embedded clocked audio input component) in this testbench by selecting `G_INCLUDE_AVALON_ST = 1`.

Design Example

Altera provides a design example with the SDI Audio Embed and Audio Extract MegaCore functions. This design example include the SDI Audio MegaCore functions and instances of the SDI MegaCore function.

This section discusses the requirements and related procedures to demonstrate the SDI Audio example design with the Stratix IV GX Audio Video Development Kit. This section contains the following topics:

- [Components](#)
- [Hardware and Software Requirements](#)
- [Hardware Setup](#)
- [Running the Design Example](#)

Components

Figure 4-9 shows a high-level block diagram of the design example.

Figure 4-9. High-Level Block Diagram of Stratix IV GX FPGA

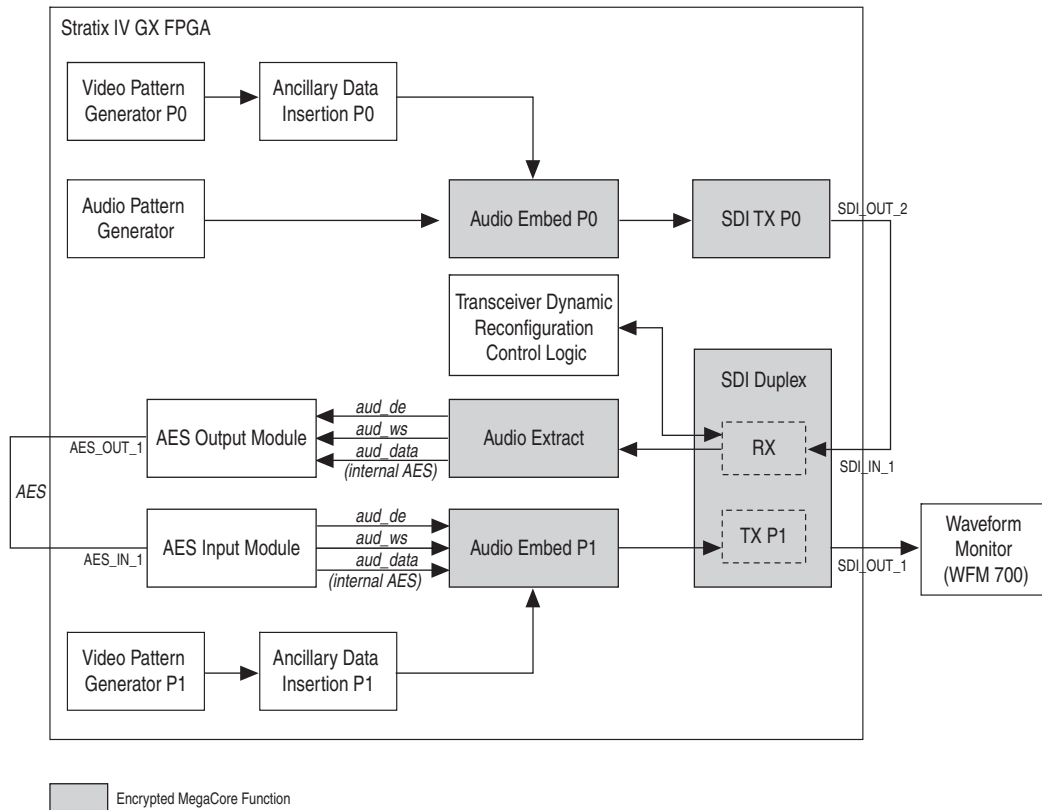

The following sections describe the various elements in Figure 4-9.

SDI Transmitter P0

The triple-standard SDI transmitter that outputs a 3G-SDI (2.970 Gbps), HD-SDI (1.485 Mbps), or SD-SDI (270 Mbps) data stream. This transmitter gets the parallel data source from the SDI Audio Embed MegaCore function. The SDI Audio Embed component embeds the internally generated audio in AES format into the internally generated video. The transmitter transmits the serial signal through a BNC cable to the receiver of the SDI duplex instance.

SDI Duplex

The triple-standard SDI duplex provides a full-duplex SD-SDI, HD-SDI, and 3G-SDI standards. The SDI duplex instance routes the received data to the SDI Audio Extract MegaCore function to extract the AES audio. The SDI Audio Embed MegaCore function embeds the internally generated audio in AES format into the internally generated video. The transmitter in this duplex connects its output to the external waveform monitor, such as the WFM700.

Audio Extract

The Audio Extract MegaCore function extracts the embedded AES audio from the SDI stream. The Audio Extract MegaCore function routes the extracted AES audio to the AES output of the daughter card.

AES Output Module

The AES output module converts the `aud_de`, `aud_ws`, and `aud_data` signals to AES signal. This module configures the extracted internal AES audio signal, `aud_data`, without the biphase mark encoding. When this module interfaces with the Audio Extract MegaCore function, it must use the same clock as the Audio Extract MegaCore function.

AES Input Module

The AES input module converts the AES signal to `aud_de`, `aud_ws`, and `aud_data` (internal AES) signals to interface with Audio Embed P1. When this module interfaces with the Audio Embed MegaCore function, both must use the same clock.

Audio Embed P0/P1

The Audio Embed P0 embeds the AES audio generated by the Audio Pattern Generator into the video stream, as a transmitting data, for the SDI transmitter P0. The Audio Embed P1 embeds the AES audio from the external AES input into the video stream for the SDI duplex.

Video Pattern Generator P0/P1

You can configure the internal video pattern generator to output an SD-SDI, HD-SDI, 3G-SDI Level A or 3G-SDI Level B colorbar pattern.

Audio Pattern Generator

You can configure the internal audio pattern generator to create an AES audio test sample that comprises an increasing count. You configure the generator using the 48-kHz clock output from the Audio Embed MegaCore function.

Ancillary Data Insertion P0/P1

The Ancillary Data Insertion module inserts the ancillary data defined by SMPTE352 into the SDI video stream.

Transceiver Dynamic Reconfiguration Control Logic

The transceiver dynamic reconfiguration control logic block handles the reconfiguration of the receiver in the SDI duplex.

Hardware and Software Requirements

The demonstration requires the following hardware and software:

- Stratix IV GX Audio Video Development Kit—Stratix IV GX FPGA development board and SDI HSMC
- SDI MegaCore function
- SDI Audio Embed MegaCore function
- SDI Audio Extract MegaCore function
- The Quartus II software, version 11.1

 For more information about how the Stratix IV GX FPGA development board connects to the SDI HSMC, refer to *AN 600: Serial Digital Interface Reference Design for Stratix IV Devices*.

You can obtain the design example from the directory structure in [Figure 4-10](#).

Figure 4-10. Directory Structure

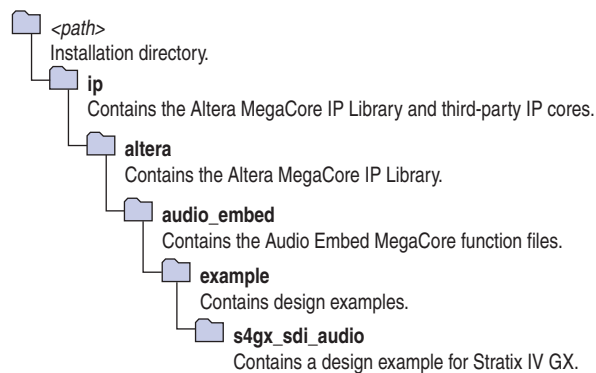

Hardware Setup

[Table 4-30](#) lists the function of each LED on the Stratix IV GX FPGA development board.

Table 4-30. Function of Each LED on the Stratix IV GX FPGA Development Board

LED	Description
D23	Indicates the presence of audio group 1 data packet in the incoming embedded audio.
D22	Indicates the presence of audio group 2 data packet in the incoming embedded audio.
D21	Indicates the presence of audio group 3 data packet in the incoming embedded audio.
D20	Indicates the presence of audio group 4 data packet in the incoming embedded audio.
D19	Indicates that the receiver of the SDI duplex MegaCore function is alignment locked.

Table 4-30. Function of Each LED on the Stratix IV GX FPGA Development Board

LED	Description
D18	Indicates that the receiver of the SDI duplex MegaCore function is TRS locked.
D17	Indicates that the receiver of the SDI duplex MegaCore function is frame locked.
D16	Indicates the recovered clock heartbeat of the receiver.
D13	Indicates the ancillary checksum failure.
D12	Indicates the ancillary parity failure.
D11	Indicates the channel status CRC failure.
D10	Indicates the audio packet failure.
D9-D8	Indicate the SDI receive video standards. 00 = SD-SDI, 01 = HD-SDI, 11 = 3G-SDI Level A, 10 = 3G-SDI Level B
D7-D6	Indicate the SDI transmit video standards. 00 = SD-SDI, 01 = HD-SDI, 11 = 3G-SDI Level A, 10 = 3G-SDI Level B

Table 4-31 lists the function of each user-defined dual in-line package (DIP) switch settings.

Table 4-31. Function of Each DIP Switch

DIP Switch	Description
8	Resets the system.
7	Resets the Audio Extract MegaCore function status registers.
6-3	Unused.
2-1	Configure the internally-generated video standards for both SDI transmitters. 00 = SD-SDI, 01 = HD-SDI, 11 = 3G-SDI Level A, 10 = 3G-SDI Level B When 00, enables the embedding of audio group 1, When 01, enables the embedding of audio group 1 and 2, When 11, enables the embedding of audio group 1, 2, and 3, When 10, enables the embedding of audio group 1, 2, 3, and 4

Running the Design Example

To run the design example, you must set up the development board.

To set up the development board, follow these steps:

1. Set up the board connections.
 - a. Connect the SDI HSMC to HSMA port on the Stratix IV GX development board.
 - b. Connect the development board to the power supply.
 - c. Connect the SDI_OUT_2 port (SDI TX P0) to the SDI_IN_1 port (SDI duplex) using external BNC cable.
 - d. Connect the AES_OUT_1 port to the AES_IN_1 port using external BNC cable.
 - e. Connect the SDI_OUT_1 port (SDI duplex) to the external waveform monitor so that you can analyze the embedded audio in the SDI video stream.
2. Launch the Quartus II software.
 - a. On the File menu, click **Open Project**, navigate to `ip/altera/audio_embed/example/s4gx_sdi_audio/s4gx_sdi_audio.qpf`, and click **Open**.
 - b. On the Processing menu, click **Start Compilation**.
3. Download the Quartus II-generated SRAM Object File (.sof).

After you set up the board, run the different configurations described in the following sections.

Transmit SD-SDI with Embedding of Audio Group 1

To transmit the SD-SDI video standard, follow these steps:

1. Set DIP switch[2:1] = 00
2. The demonstration runs and the LEDs indicate the following conditions:
 - a. LED D16 blinks indicating the heartbeat of the receiver's recovered clock.
 - b. LED D17 illuminates when the receiver is frame locked.
 - c. LED D18 illuminates when the receiver is TRS locked.
 - d. LED D19 illuminates when the receiver is alignment locked.
 - e. LED D23 illuminates when the data packet of audio group 1 is detected in the incoming SDI stream.

Figure 4-11 shows the condition of the LEDs.

Figure 4-11. Condition of LEDs for Transmitting SDI-SDI Video Standard

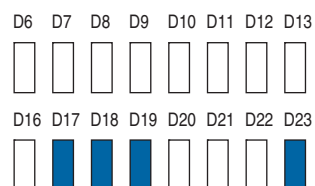

3. The external waveform monitor (WFM700) displays the following observation:
 - a. Colorbar video pattern
 - b. Video format detect is 625i 50.00
 - c. Embedded audio standard detected is SMPTE272M
 - d. Audio channel pairs (1,2) and (3,4) are present

Transmit HD-SDI with Embedding of Audio Group 1 and 2

To transmit the HD-SDI video standard, follow these steps:

1. Set DIP switch[2:1] = 01
2. The demonstration runs and the LEDs indicate the following conditions:
 - a. LED D6 and D7 indicate the internal video pattern generator signal standard.
 - b. LED D8 and D9 indicate the receive video standard.
 - c. LED D16 blinks indicating the heartbeat of the receiver's recovered clock. The frequency is blinking is slower than the previous demonstration.
 - d. LED D17 illuminates when the receiver is frame locked.
 - e. LED D18 illuminates when the receiver is TRS locked.
 - f. LED D19 illuminates when the receiver is alignment locked.
 - g. LED D23 and D22 illuminate when the data packet of audio groups 1 and 2 are detected in the incoming SDI stream.

Figure 4-12 shows the condition of the LEDs.

Figure 4-12. Condition of LEDs for Transmitting HDI-SDI Video Standard

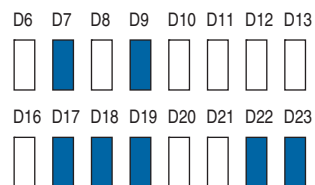

3. The external waveform monitor (WFM700) displays the following observation:
 - a. Colorbar video pattern
 - b. Video format detect is 1080i 60.00
 - c. Embedded audio standard detected is SMPTE299M
 - d. Audio channel pairs (1,2), (3,4), (5,6) and (7,8) are present

Transmit 3G-SDI Level A with Embedding of Audio Group 1, 2 and 3

To transmit the 3G-SDI Level A video standard, follow these steps:

1. Set DIP switch[2:1] = 11
2. The demonstration runs and the LEDs indicate the following conditions:
 - a. LED D6 and D7 indicate the internal video pattern generator signal standard.
 - b. LED D8 and D9 indicate the receive video standard.
 - c. LED D16 blinks indicating the heartbeat of the receiver's recovered clock.
 - d. LED D17 illuminates when the receiver is frame locked.
 - e. LED D18 illuminates when the receiver is TRS locked.
 - f. LED D19 illuminates when the receiver is alignment locked.
 - g. LED D23, D22 and D21 illuminate when the data packet of audio groups 1, 2 and 3 are detected in the incoming SDI stream.

Figure 4-13 shows the condition of the LEDs.

Figure 4-13. Condition of LEDs for Transmitting 3G-SDI Level A Video Standard

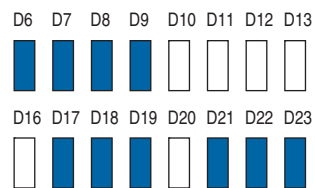

Transmit 3G-SDI Level B with Embedding of Audio Group 1, 2, 3 and 4

To transmit the 3G-SDI Level B video standard, follow these steps:

1. Set DIP switch[2:1] = 10
2. The demonstration runs and the LEDs indicate the following conditions:
 - a. LED D6 and D7 indicate the internal video pattern generator signal standard.
 - b. LED D8 and D9 indicate the receive video standard.
 - c. LED D16 blinks indicating the heartbeat of the receiver's recovered clock.
 - d. LED D17 illuminates when the receiver is frame locked.
 - e. LED D18 illuminates when the receiver is TRS locked.
 - f. LED D19 illuminates when the receiver is alignment locked.
 - g. LED D23, D22, D21 and D20 illuminate when the data packet of audio groups 1, 2, 3 and 4 are detected in the incoming SDI stream.

Figure 4-14 shows the condition of the LEDs.

Figure 4-14. Condition of LEDs for Transmitting 3G-SDI Level B Video Standard



For the SDI MegaCore function to work reliably, you must implement the following Quartus II constraints:

- Specify clock characteristics
- Set timing exceptions such as false path, maximum and minimum delays, and multicycle path
- Minimize the timing skew among the paths from I/O pins to the four sampling registers
- Set the oversampling clock that the oversampling interface to 135 MHz uses as an independent clock domain

Specifying TimeQuest Timing Analyzer Constraints

To ensure your design meets timing and other requirements, you must constrain the design. This section provides the necessary steps to properly constrain your SDI design using the TimeQuest timing analyzer.

1. Make sure that TimeQuest is specified as the default timing analyzer in the **Timing Analysis Settings** page of the **Settings** dialog box.
2. Perform initial compilation to create an initial design database before you specify timing constraints for your design. On the Processing menu, click **Start Compilation**. A message indicates when compilation is complete.
3. On the Tools menu, click **TimeQuest Timing Analyzer**.
4. Create timing netlist, double-click **Create Timing Netlist** in the **Tasks** pane. The timing netlist appears in the **Report** pane.
5. Specify timing constraints and exceptions. To enter your timing requirements, you can use constraint entry dialog boxes or edit the previously created **.sdc** file.
6. To save your constraints in an **.sdc** file, on the Constraints menu, click **Write SDC File**.

Figure A-1 shows the flow of the constraint design.

Figure A-1. Constraints Design Flow

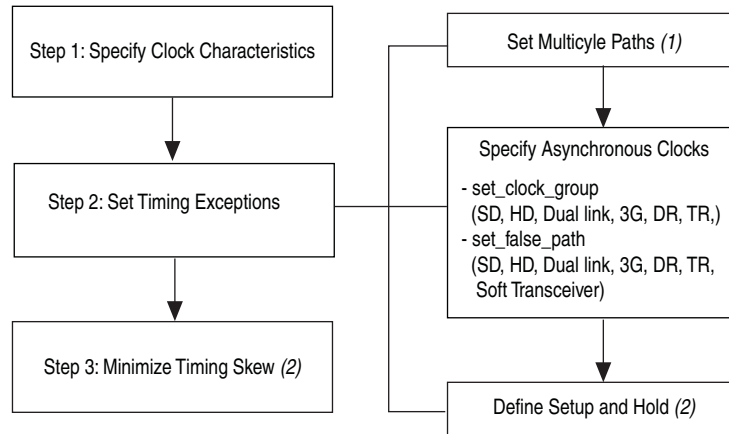

Notes to Figure A-1:

- (1) Applicable for SD-SDI only.
- (2) Applicable for Soft SERDES only.

Table A-1 through Table A-3 show the values for the constraints.

Table A-1. Step 1: Specify Clock Characteristics

Standard	Clocks	Units
SDI-SD	transceiver_data_rate	270 Mbps
	tx_pclk	27 MHz
	tx_serial_refclk	67.5 MHz
	rx_sd_oversample_clk_in	67.5 MHz
HD-SDI, HD-SDI dual link	transceiver_data_rate	1485 Mbps
	tx_pclk	74.25 MHz
	tx_serial_refclk	74.25 MHz
3G-SDI	transceiver_data_rate	2970 Mbps
	tx_pclk	148.5 MHz
	tx_serial_refclk	148.5 MHz
	rx_serial_refclk	148.5 MHz
DR, TR	transceiver_data_rate	2970 Mbps
	tx_pclk	148.5 MHz
	tx_serial_refclk	148.5 MHz
	rx_serial_refclk	148.5 MHz
Soft transceiver SDI	rx_sd_refclk_135	135 MHz
	rx_sd_refclk_337	337 MHz
	rx_sd_refclk_337_90°	337 MHz
	tx_sd_refclk_270	270 MHz
	tx_pclk	27 MHz

Table A-2. Step 2: Set Timing Exceptions (Part 1 of 2)

Standard	Set Multicycle Paths	set_clock_group	set_false_path (1)	Define Setup and Hold Relationship
SD-SDI	u_format* to u_format	tx_pclk, transmit_pcs0 clkout(g xb_tx_coreclk)	switchline, get_clocks receive_pcs0 clkout (gxb_rxclk)	—
HD-SDI, HD-SDI dual link, 3G-SDI, DR, TR	—	rx_serial_refclk, receive_pcs0 clkout (gxb_rxclk)	switchline, get_clocks receive_pcs0 clkout (gxb_rxclk)	—
		tx_pclk, transmit_pcs0 clkout(g xb_tx_coreclk)	—	

Table A-2. Step 2: Set Timing Exceptions (Part 2 of 2)

Standard	Set Multicycle Paths	set_clock_group	set_false_path ⁽¹⁾	Define Setup and Hold Relationship
Soft transceiver SDI	—	—	switchline, get_clocks receive_pcs0 clkout (gxb_rxclk)	Setup—1.5 clocks (4.43 ns) from the 337.5-MHz zero-degree clock to the 135-MHz clock Hold—zero clocks from the 337.5-MHz clock to the 135-MHz clock

Note to Table A-2:

(1) Switchline is an internal signal equivalent to the en_switch_reg signal in Figure 3-6.

Table A-3. Step 3: Minimize the Timing Skew

Standard	Minimize Timing Skew
SD-SDI	—
HD-SDI, HD-SDI dual link	—
3G-SDI	—
DR, TR	—
Soft transceiver SDI	I/O to sample_a b c d[0] path as short as possible

The following constraints are specifically used to constrain a duplex SDI MegaCore function targeting Stratix IV device:

- Specify Clock Characteristics
- Set Multicycle Paths
- Minimize Timing Skew

Specify Clock Characteristics

Use the following constraints for the TimeQuest timing analyzer:

- SD-SDI (rx_sd_oversample_clk_in = 67.5 MHz, tx_pclk = 27 MHz, tx_serial_refclk = 67.5 MHz)

```
create_clock -name {rx_sd_oversample_clk_in} -period 14.814 -waveform { 0.000 7.407 } [get_ports {rx_sd_oversample_clk_in}]
```

```
create_clock -name {tx_pclk} -period 14.814 -waveform { 0.000 7.407 } [get_ports {tx_pclk}]
```

```
create_clock -name {tx_serial_refclk} -period 14.814 -waveform { 0.000 7.407 } [get_ports {tx_serial_refclk}]
```

- HD-SDI, HD-SDI dual link (rx_serial_refclk = 74.25 MHz, tx_pclk = 74.25 MHz, tx_serial_refclk = 74.25 MHz)

```
create_clock -name {rx_serial_refclk} -period 13.468 -waveform { 0.000 6.734 } [get_ports {rx_serial_refclk}]
```

```
create_clock -name {tx_pclk} -period 13.468 -waveform { 0.000 6.734 } [get_ports {tx_pclk}]
```

```
create_clock -name {tx_serial_refclk} -period 13.468 -waveform { 0.000
6.734 } [get_ports {tx_serial_refclk}]
```

- 3G-SDI (rx_serial_refclk = 148.5 MHz, tx_pclk = 148.5 MHz, tx_serial_refclk = 148.5 MHz)

```
create_clock -name {rx_serial_refclk} -period 6.734 -waveform { 0.000
3.367 } [get_ports {rx_serial_refclk}]
```

```
create_clock -name {tx_pclk} -period 6.734 -waveform { 0.000 3.367 }
[get_ports {tx_pclk}]
```

```
create_clock -name {tx_serial_refclk} -period 6.734 -waveform { 0.000
3.367 } [get_ports {tx_serial_refclk}]
```

- Dual standard, triple standard SDI

```
create_clock -name {rx_serial_refclk} -period 6.734 -waveform { 0.000
3.367 } [get_ports {rx_serial_refclk}]
```

```
create_clock -name {tx_serial_refclk} -period 6.734 -waveform { 0.000
3.367 } [get_ports {tx_serial_refclk}]
```

```
create_clock -name {tx_pclk} -period 6.734 -waveform { 0.000 3.367 }
[get_ports {tx_pclk}]
```

- Soft transceiver SDI

```
create_clock -name {rx_sd_refclk_135} -period 7.407 -waveform { 0.000
3.703 } [get_ports {rx_sd_refclk_135}]
```

```
create_clock -name {rx_sd_refclk_337} -period 2.967 -waveform { 0.000
1.484 } [get_ports {rx_sd_refclk_337}]
```

```
create_clock -name {rx_sd_refclk_337_90deg} -period 2.967 -waveform {
0.000 1.484 } [get_ports {rx_sd_refclk_337_90deg}]
```

```
create_clock -name {tx_sd_refclk_270} -period 3.703 -waveform { 0.000
1.852 } [get_ports {tx_sd_refclk_270}]
```

```
create_clock -name {tx_pclk} -period 37.037 -waveform { 0.000 18.519 }
[get_ports {tx_pclk}]
```

Set Multicycle Paths

In some device families and speed grades, timing violations may occur in the format block of the SDI MegaCore function. For SD-SDI, these violations are multicycle, and can be fixed by applying the following constraints to your design, (these constraints apply only to SD-SDIs; they are single-cycle paths in all other video standards).

```
set_multicycle_path -setup -end -from [get_keepers
{sdi_megacore_top:sdi_megacore_top_inst|sdi_txxr_port:sdi_txxr_port_ge
n[0].u_txxr_port|sdi_format:format_gen.u_format|*}] -to [get_keepers
{sdi_megacore_top:sdi_megacore_top_inst|sdi_txxr_port:sdi_txxr_port_ge
n[0].u_txxr_port|sdi_format:format_gen.u_format|*}] 2
```

```
set_multicycle_path -hold -end -from [get_keepers
{sdi_megacore_top:sdi_megacore_top_inst|sdi_txxr_port:sdi_txxr_port_ge
n[0].u_txxr_port|sdi_format:format_gen.u_format|*}] -to [get_keepers
{sdi_megacore_top:sdi_megacore_top_inst|sdi_txxr_port:sdi_txxr_port_ge
n[0].u_txxr_port|sdi_format:format_gen.u_format|*}] 1
```

Specify Clocks that are Exclusive or Asynchronous

The SDI MegaCore function may show timing violations in slower speed grade devices. These paths are not required to have fast timing, so you can use the following constraints to remove these timing paths. You can use the command `set_clock_groups` or `set_false_path`.

 The following SDC commands are only applicable for duplex core and Stratix IV devices, you must use the constraint entry dialog boxes to constrain the separate receiver or transmitter core and other device families.

■ SD-SDI

```
set_clock_groups -exclusive -group [get_clocks {tx_pclk}] -group
[get_clocks
{sdi_megacore_top_inst|sdi_txxr_port_gen[0].u_txxr_port|gen_duplex_alt
4gxb.u_gxb|alt4gxb_component|auto_generated|transmit_pcs0|clkout}]

set_false_path -from [get_keepers
{sdi_megacore_top:sdi_megacore_top_inst|sdi_txxr_port:sdi_txxr_port_ge
n[0].u_txxr_port|switchline}] -to [get_clocks
{sdi_megacore_top_inst|sdi_txxr_port_gen[0].u_txxr_port|gen_duplex_alt
4gxb.u_gxb|alt4gxb_component|auto_generated|receive_pcs0|clkout}]
```

■ HD-SDI, 3G-SDI, dual standard, triple standard SDI

```
set_clock_groups -exclusive -group [get_clocks {rx_serial_refclk}] -
group [get_clocks
{sdi_megacore_top_inst|sdi_txxr_port_gen[0].u_txxr_port|gen_duplex_alt
4gxb.u_gxb|alt4gxb_component|auto_generated|receive_pcs0|clkout}]

set_clock_groups -exclusive -group [get_clocks {tx_pclk}] -group
[get_clocks
{sdi_megacore_top_inst|sdi_txxr_port_gen[0].u_txxr_port|gen_duplex_alt
4gxb.u_gxb|alt4gxb_component|auto_generated|transmit_pcs0|clkout}]

set_false_path -from [get_keepers
{sdi_megacore_top:sdi_megacore_top_inst|sdi_txxr_port:sdi_txxr_port_ge
n[0].u_txxr_port|switchline}] -to [get_clocks
{sdi_megacore_top_inst|sdi_txxr_port_gen[0].u_txxr_port|gen_duplex_alt
4gxb.u_gxb|alt4gxb_component|auto_generated|receive_pcs0|clkout}]
```

■ HD-SDI dual link (for the additional channel)

```
set_clock_groups -exclusive -group [get_clocks {rx_serial_refclk}] -
group [get_clocks
{sdi_megacore_top_inst|sdi_txxr_port_gen[1].u_txxr_port|gen_duplex_alt
4gxb.u_gxb|alt4gxb_component|auto_generated|receive_pcs0|clkout}]

set_false_path -from [get_keepers
{sdi_megacore_top:sdi_megacore_top_inst|sdi_txxr_port:sdi_txxr_port_ge
n[0].u_txxr_port|switchline}] -to [get_clocks
{sdi_megacore_top_inst|sdi_txxr_port_gen[0].u_txxr_port|gen_duplex_alt
4gxb.u_gxb|alt4gxb_component|auto_generated|receive_pcs0|clkout}]

set_clock_groups -exclusive -group [get_clocks {tx_pclk}] -group
[get_clocks
{sdi_megacore_top_inst|sdi_txxr_port_gen[1].u_txxr_port|gen_duplex_alt
4gxb.u_gxb|alt4gxb_component|auto_generated|transmit_pcs0|clkout}]

set_false_path -from [get_keepers
{sdi_megacore_top:sdi_megacore_top_inst|sdi_txxr_port:sdi_txxr_port_ge
n[1].u_txxr_port|switchline}] -to [get_clocks
{sdi_megacore_top_inst|sdi_txxr_port_gen[1].u_txxr_port|gen_duplex_alt
4gxb.u_gxb|alt4gxb_component|auto_generated|receive_pcs0|clkout}]
```

Define the Setup and Hold Relationship between 135-MHz Clocks and 337.5-MHz Zero-degree Clocks

These constraints apply only to soft transceiver SDI.

- Setup—1.5 clocks (4.43 ns) from the 337.5-MHz zero-degree clock to the 135-MHz clock

- Hold—zero clocks from the 337.5-MHz clock to the 135-MHz clock

Use the `set_min_delay` command to specify an absolute minimum delay for a given path.

```
set_min_delay -from [get_clocks {rx_sd_refclk_337}] -to [get_clocks
{rx_sd_refclk_135}] 0.000
```

Use the `set_max_delay` command to specify an absolute maximum delay for a given path.

```
set_max_delay -from [get_clocks {rx_sd_refclk_337}] -to [get_clocks
{rx_sd_refclk_135}] 4.430
```

Minimize Timing Skew

You must minimize the timing skew among the paths from I/O pins to the four sampling registers (`sample_a[0]`, `sample_b[0]`, `sample_c[0]`, and `sample_d[0]`). To minimize the timing skew, manually place the sampling registers close to each other and to the serial input pin. Because these four registers are using four different clock domains, place two of the four registers in one LAB and the other two in another LAB. Furthermore, place the two chosen LABs within the same row regardless of the placement of the serial input. Finally, do not place the four sampling registers at the immediate rows or columns next to the I/O, but at the second row or column next to the I/O bank. This location is because inter-LAB interconnects between I/O banks and their immediate rows or columns are much faster than core interconnect.

The following code is an example of a constraint, which you can set using the Quartus II Assignment Editor:

```
set_location_assignment PIN_99 -to sdi_rx

set_location_assignment LC_X32_Y17_N0 -to
"sdi_megacore_top:sdi_megacore_top_inst|sdi_txxr_port:sdi_txxr_port_ge
n[0].u_txxr_port|soft_serdes_rx:rx_soft_serdes_gen.soft_serdes_rx_inst
|serdes_s2p:u_s2p|sample_a[0]"

set_location_assignment LC_X33_Y17_N0 -to
"sdi_megacore_top:sdi_megacore_top_inst|sdi_txxr_port:sdi_txxr_port_ge
n[0].u_txxr_port|soft_serdes_rx:rx_soft_serdes_gen.soft_serdes_rx_inst
|serdes_s2p:u_s2p|sample_b[0]"

set_location_assignment LC_X32_Y17_N1 -to
"sdi_megacore_top:sdi_megacore_top_inst|sdi_txxr_port:sdi_txxr_port_ge
n[0].u_txxr_port|soft_serdes_rx:rx_soft_serdes_gen.soft_serdes_rx_inst
|serdes_s2p:u_s2p|sample_c[0]"

set_location_assignment LC_X33_Y17_N1 -to
"sdi_megacore_top:sdi_megacore_top_inst|sdi_txxr_port:sdi_txxr_port_ge
n[0].u_txxr_port|soft_serdes_rx:rx_soft_serdes_gen.soft_serdes_rx_inst
|serdes_s2p:u_s2p|sample_d[0]"
```

Constraints for the SDI Soft Transceiver

There are constraints specific only to Cyclone devices and there are other constraints that apply to the other devices (including Cyclone II, Cyclone III and Cyclone IV devices). There are also different constraints that apply to the Classic timing analyzer and the TimeQuest timing analyzer.

Non Cyclone Devices

These constraints apply to all device families (excluding Cyclone, but including Cyclone II, Cyclone III and Cyclone IV devices) that are configured to use a soft transceiver for their receivers.

Define the following setup and hold relationship between the 135-MHz clocks and the 337.5-MHz zero-degree clocks:

- Setup—1.5 clocks (4.43 ns) from the 337.5-MHz zero-degree clock to the 135-MHz clock
- Hold—zero clocks from the 337.5-MHz clock to the 135-MHz clock

If you choose to include the PLLs inside the MegaCore function, modify the following constraints and apply them to your design. Alternatively, apply similar constraints to the clocks connected to the rx_sd_refclk_337 and rx_sd_refclk_135 signals on your SDI MegaCore function.

Classic Timing Analyzer

Use the following constraints for the Classic timing analyzer:

```
set_instance_assignment -name SETUP_RELATIONSHIP "4.43 ns" -from
"<your_megacore:your_megacore_inst>|sdi_megacore_top:sdi_megacore_top_
inst|sdi_clocks:u_sdi_clocks|stratix_c2_pll_sclk:u_rx_pll|altpll:altpl
l_component|_clk0" -to
"<your_megacore:your_megacore_inst>|sdi_megacore_top:sdi_megacore_top_
inst|sdi_clocks:u_sdi_clocks|stratix_c2_pll_sclk:u_rx_pll|altpll:altpl
l_component|_clk2"

set_instance_assignment -name HOLD_RELATIONSHIP "0 ns" -from
"<your_megacore:your_megacore_inst>|sdi_megacore_top:sdi_megacore_top_
inst|sdi_clocks:u_sdi_clocks|stratix_c2_pll_sclk:u_rx_pll|altpll:altpl
l_component|_clk0" -to
"<your_megacore:your_megacore_inst>|sdi_megacore_top:sdi_megacore_top_
inst|sdi_clocks:u_sdi_clocks|stratix_c2_pll_sclk:u_rx_pll|altpll:altpl
l_component|_clk2"
```

TimeQuest Timing Analyzer

Use the following constraints for the TimeQuest timing analyzer:

```
set_max_delay 4.43 -from
{<your_megacore:your_megacore_inst>|sdi_megacore_top:sdi_megacore_top_
inst|sdi_clocks:u_sdi_clocks|stratix_c2_pll_sclk:u_rx_pll|altpll:altpl
l_component|_clk0} -to
{<your_megacore:your_megacore_inst>|sdi_megacore_top:sdi_megacore_top_
inst|sdi_clocks:u_sdi_clocks|stratix_c2_pll_sclk:u_rx_pll|altpll:altpl
l_component|_clk2}

set_min_delay 0 -from {
<your_megacore:your_megacore_inst>|sdi_megacore_top:sdi_megacore_top_i
nst|sdi_clocks:u_sdi_clocks|stratix_c2_pll_sclk:u_rx_pll|altpll:altpl
l_component|_clk0} -to
{<your_megacore:your_megacore_inst>|sdi_megacore_top:sdi_megacore_top_
inst|sdi_clocks:u_sdi_clocks|stratix_c2_pll_sclk:u_rx_pll|altpll:altpl
l_component|_clk2}
```

Cyclone Devices Only

These constraints apply to Cyclone devices only (not Cyclone II, Cyclone III, or other device families).

Classic Timing Analyzer

Use the following constraints for the Classic timing analyzer:

```
set_global_assignment -name FMAX_REQUIREMENT "27 MHz" -section_id
input_refclk

set_instance_assignment -name CLOCK_SETTINGS input_refclk -to
rx_27_refclk

set_instance_assignment -name CLOCK_SETTINGS rxclk -to
"<your_megacore>|sdi_megacore_top:sdi_megacore_top_inst|sdi_clocks:u_s
di_clocks|clkdiv_2p5:cyc_rx_pll_gen.u_clkdiv|clkdiv"

set_global_assignment -name BASED_ON_CLOCK_SETTINGS input_refclk -
section_id rxclk

set_global_assignment -name MULTIPLY_BASE_CLOCK_PERIOD_BY 5 -section_id
rxclk

set_global_assignment -name DIVIDE_BASE_CLOCK_PERIOD_BY 25 -section_id
rxclk

set_global_assignment -name ENABLE_CLOCK_LATENCY ON

set_instance_assignment -name SETUP_RELATIONSHIP "4.43 ns" -from
"<your_megacore>|sdi_megacore_top:sdi_megacore_top_inst|sdi_clocks:u_s
di_clocks|pll_sclk:cyc_rx_pll_gen.u_rx_pll|altpll:altpll_component|_cl
k0" -to
"<your_megacore>|sdi_megacore_top:sdi_megacore_top_inst|sdi_clocks:u_s
di_clocks|clkdiv_2p5:cyc_rx_pll_gen.u_clkdiv|clkdiv"

set_instance_assignment -name HOLD_RELATIONSHIP "0 ns" -from
"<your_megacore>|sdi_megacore_top:sdi_megacore_top_inst|sdi_clocks:u_s
di_clocks|pll_sclk:cyc_rx_pll_gen.u_rx_pll|altpll:altpll_component|_cl
k0" -to
"<your_megacore>|sdi_megacore_top:sdi_megacore_top_inst|sdi_clocks:u_s
di_clocks|clkdiv_2p5:cyc_rx_pll_gen.u_clkdiv|clkdiv"
```

TimeQuest Timing Analyzer

Use the following constraints for the TimeQuest timing analyzer:

```
derive_pll_clocks -use_tan_name

create_clock -name rx_27_refclk -period 37.037 -waveform { 0.000 18.518
} [get_ports {rx_27_refclk}]

create_clock -name tx_27_refclk -period 37.037 -waveform { 0.000 18.518
} [get_ports {tx_27_refclk}]

create_generated_clock -name
<your_megacore>|sdi_megacore_top:sdi_megacore_top_inst|sdi_clocks:u_sd
i_clocks|clkdiv_2p5:cyc_rx_pll_gen.u_clkdiv|clkdiv \
    -source
<your_megacore>|sdi_megacore_top:sdi_megacore_top_inst|sdi_clocks:u_sd
i_clocks|pll_sclk:cyc_rx_pll_gen.u_rx_pll|altpll:altpll_component|_clk
0 \
    -multiply_by 2 \
    -divide_by 5
```

```
set_max_delay -from [get_clocks
{<your_megacore>|sdi_megacore_top:sdi_megacore_top_inst|sdi_clocks:u_s
di_clocks|pll_sclk:cyc_rx_pll_gen.u_rx_pll|altpll:altpll_component|_cl
k0}] -to [get_clocks
{<your_megacore>|sdi_megacore_top:sdi_megacore_top_inst|sdi_clocks:u_s
di_clocks|clkdiv_2p5:cyc_rx_pll_gen.u_clkdiv|clkdiv}] 4.430

set_min_delay -from [get_clocks
{<your_megacore>|sdi_megacore_top:sdi_megacore_top_inst|sdi_clocks:u_s
di_clocks|pll_sclk:cyc_rx_pll_gen.u_rx_pll|altpll:altpll_component|_cl
k0}] -to [get_clocks
{<your_megacore>|sdi_megacore_top:sdi_megacore_top_inst|sdi_clocks:u_s
di_clocks|clkdiv_2p5:cyc_rx_pll_gen.u_clkdiv|clkdiv}] 0.000
```

Figure B-1 shows the transceiver clocks for the SDI MegaCore function for version 7.0 and previous.

Figure B-1. Version 7.0 and Earlier Clocks

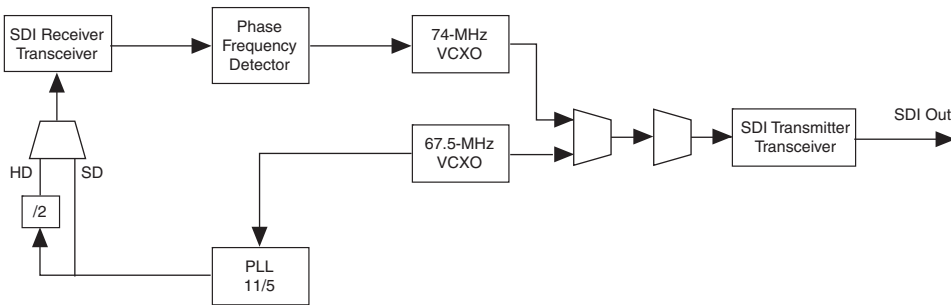

Figure B-2 shows how you must clock the transceivers for current SDI cores. You can now derive all clocks from a single 148.5-MHz voltage controlled crystal oscillator (VCXO) and the transceivers require no external multiplexing.

Figure B-2. Version 7.1 and Later Clocks

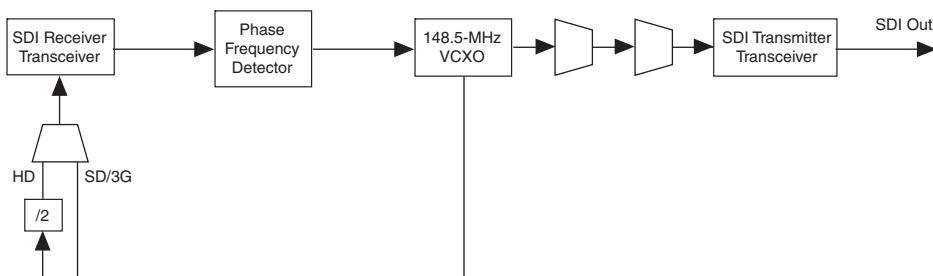

Figure B-3 shows how you must clock the transceivers for version 7.1 and later SDI cores with international clocking. Both American and European standards are catered for.

Figure B-3. Version 7.1 and Later International Clocks

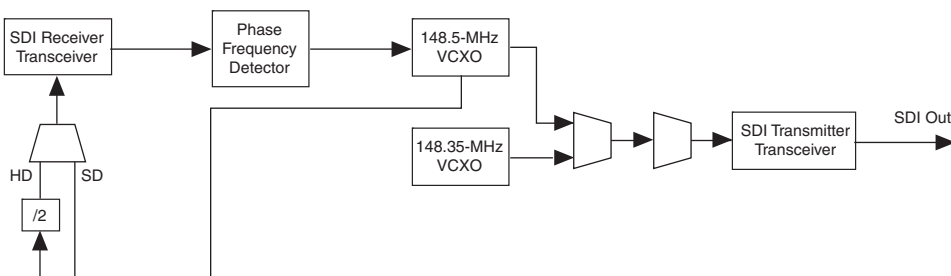
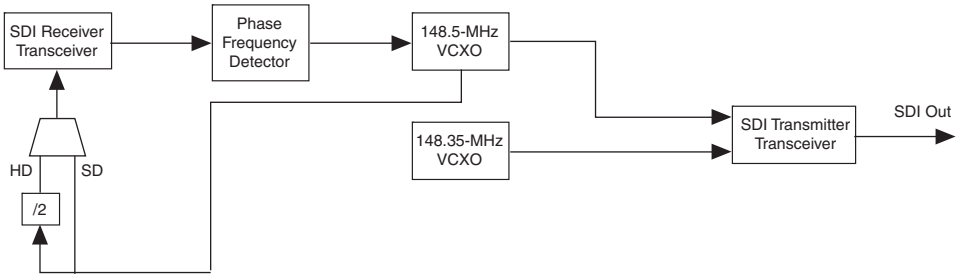

Figure B-3 shows how you must clock the transceivers for version 7.1 and later SDI cores with international clocking. Both American and European standards are catered for.

Figure B-1. Version 11.1 and Later International Clocks (Optional)



You cannot reuse the HD and 3G recovered clocks for transmitting because the transmitter jitter is then entirely dependent on the input jitter and jitter transfer function.

The general recommended approach to system locking with the SDI MegaCore function is to use a voltage-controlled crystal oscillator (VCXO) external to the device. The VCXO must be locked to the receiver clock out of the SDI MegaCore function. The SDI MegaCore function then uses the clean VCXO output as the transmit clock.

Loopback FIFO Buffer

For more efficient transmission, place a FIFO or buffer between the receiver clock domain logic and the transmit clock domain logic. The decoded receiver data is connected to the transmitter input through a FIFO buffer. When the receiver is locked, the logic writes the receiver data to the FIFO buffer. When the FIFO is half full, the transmitter starts reading, encoding and transmitting the data.

Figure C-1 shows the clocking scheme of the received and retransmitted data.

Figure C-1. Receive and Retransmit

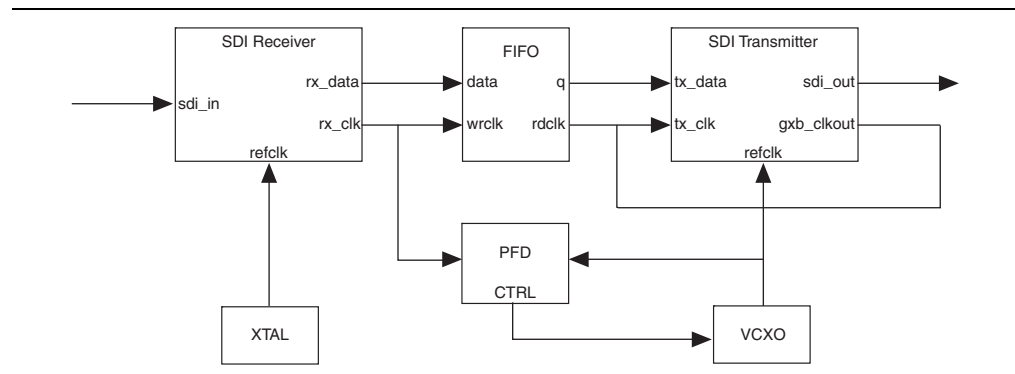

This chapter provides additional information about the document and Altera.

Document Revision History

The following table shows the revision history for this user guide.

Date	Version	Changes
February 2013	12.1	<ul style="list-style-type: none"> ■ Updated Table 1–2, Table 1–4, Table 1–5, and Table 1–7 for version 12.1 release. ■ Updated information on duplex setting in Table 3–10. ■ Updated information on rx_video_format signal in Table 3–12. ■ Added a note in Table 3–13 to include information about Arria V and Stratix V devices. ■ Added Table 3–14—transceiver PHY management clock and reset signals. ■ Updated information on rx_status signal in Table 3–18. ■ Added data width information for SDI_RECONFIG_TOGXB and SDI_RECONFIG_FROMGXB signals in Table 3–19. ■ Updated the Starting channel number parameter description in Table 3–21. ■ Added reset sequence information and timing diagram in Figure 3–25.
November 2011	11.1	<ul style="list-style-type: none"> ■ Added information about Arria V and Stratix V devices. ■ Updated Table 1–2, Table 1–5, Table 1–6, and Table 1–7 for version 11.1 release. ■ Updated “Parameterizing” section to include additional steps to turn on the Enable TX PLL select for 1/1.000 and 1/1.001 data rate reconfiguration option. ■ Updated “Transmitter Clocks”, “Transceiver—Arria GX, Arria II GX, Arria V, Cyclone IV GX, Cyclone V, Stratix II GX, Stratix IV GX, and Stratix V Devices”, Table 3–7, Table 3–9, Figure 3–3, Figure 3–8, to include information about the optional serial reference clock feature. ■ Updated Table 3–21 with Enable TX PLL select for 1/1.000 and 1/1.001 data rate reconfiguration parameter. ■ Updated information in the “Transceiver Dynamic Reconfiguration for Dual Standard and Triple Standard Receivers”. ■ Updated Table 4–1, Table 4–4, and Table 4–14 to include information about asynchronous and synchronous modes.
July 2011	11.0	<ul style="list-style-type: none"> ■ Added information about accessing transceiver. ■ Updated Table 3–12 with new signals, refclk_rate and rx_video_format. ■ Updated the high-level block diagram of design example for the SDI Audio IP Core to include AES input and output modules. ■ Updated the SDI Audio IP Core register maps.
December 2010	10.1	<ul style="list-style-type: none"> ■ Added two new GUI parameters for SDI MegaCore function: Enable Spread Spectrum feature and Tolerance to consecutive missed EAV. ■ Added a chapter on the SDI Audio IP Cores: SDI Audio Embed, Audio Extract, Clocked Audio Input, and Clocked Audio Output MegaCore functions.

Date	Version	Changes
July 2010	10.0	<ul style="list-style-type: none"> ■ Added information for Cyclone IV devices. ■ Added a section on transceiver dynamic reconfiguration with PLL reconfiguration mode - Cyclone IV GX. ■ Added transceiver dynamic reconfiguration signals for PLL reconfiguration in Table 3-18. ■ Updated Figure 3-29 and Figure 3-30 to include tx_1n signal behavior.
November 2009	9.1	<ul style="list-style-type: none"> ■ Added Cyclone III LS and Cyclone IV support. ■ Added a section on Specify Constraints. ■ Updated information on rst_rx and rst_tx signals in Table 3-15. ■ Added block diagram for input and output interface signals flow. ■ Added top-level block diagram for transmitter and receiver.
May 2009	9.0	<ul style="list-style-type: none"> ■ Added a section on Reset Requirement During Reconfiguration. ■ Updated information on txdata, tx_1n, crc_error_y, crc_error_c, rx_AP, rxdata, rx_data_valid_out, rx_F, rx_H, and rx_1n, rx_V signals in Table 3-15. ■ Updated information on rx_anc_data, rx_anc_error, rx_anc_valid and rx_status signals in Table 3-17.
March 2009	9.0	<ul style="list-style-type: none"> ■ Added Arria II GX support. ■ Added a section on RP168. ■ Updated information on video formats. ■ Removed tx_data_valid_a_bn signal.
November 2008	8.1	<ul style="list-style-type: none"> ■ Added a section on Locking Algorithm. ■ Added new signals and updated existing signal descriptions. ■ Updated Appendix A: Constraints.
May 2008	8.0	<ul style="list-style-type: none"> ■ Added Stratix IV support. ■ Improved receiver lock algorithm. ■ Updated 425MB support.
October 2007	7.2	<ul style="list-style-type: none"> ■ Updated device support. ■ Updated standards support—3G-SDI now supports <i>SMPTE425M-B 2006 3Gb/s Signal/Data Serial Interface – Source Image Format Mapping</i>. ■ Changed rx_std signal description. ■ Added tx_data_valid_a_bn signal.
May 2007	7.1	<ul style="list-style-type: none"> ■ Updated device support. ■ Added dual and triple standard information. ■ Added transceiver dynamic reconfiguration information.
December 2006	7.0	Added support for Cyclone III devices.
December 2006	6.1	Updated for new MegaWizard Plug-In Manager.

How to Contact Altera

To locate the most up-to-date information about Altera products, refer to the following table.

Contact ⁽¹⁾	Contact Method	Address
Technical support	Website	www.altera.com/support
Technical training	Website	www.altera.com/training
	Email	custrain@altera.com
Product literature	Website	www.altera.com/literature
Nontechnical support (general) (software licensing)	Email	nacomp@altera.com
	Email	authorization@altera.com







Note to Table:

(1) You can also contact your local Altera sales office or sales representative.

Typographic Conventions

The following table shows the typographic conventions this document uses.

Visual Cue	Meaning
Bold Type with Initial Capital Letters	Indicate command names, dialog box titles, dialog box options, and other GUI labels. For example, Save As dialog box. For GUI elements, capitalization matches the GUI.
bold type	Indicates directory names, project names, disk drive names, file names, file name extensions, software utility names, and GUI labels. For example, <code>\qdesigns</code> directory, D: drive, and <code>chiptrip.gdf</code> file.
<i>Italic Type with Initial Capital Letters</i>	Indicate document titles. For example, <i>Stratix IV Design Guidelines</i> .
<i>italic type</i>	Indicates variables. For example, $n + 1$. Variable names are enclosed in angle brackets (< >). For example, <code><file name></code> and <code><project name>.pof</code> file.
Initial Capital Letters	Indicate keyboard keys and menu names. For example, the Delete key and the Options menu.
“Subheading Title”	Quotation marks indicate references to sections in a document and titles of Quartus II Help topics. For example, “Typographic Conventions.”
Courier type	Indicates signal, port, register, bit, block, and primitive names. For example, <code>data1</code> , <code>tdi</code> , and <code>input</code> . The suffix <code>n</code> denotes an active-low signal. For example, <code>resetn</code> . Indicates command line commands and anything that must be typed exactly as it appears. For example, <code>c:\qdesigns\tutorial\chiptrip.gdf</code> . Also indicates sections of an actual file, such as a Report File, references to parts of files (for example, the AHDL keyword <code>SUBDESIGN</code>), and logic function names (for example, <code>TRI</code>).
↵	An angled arrow instructs you to press the Enter key.
1., 2., 3., and a., b., c., and so on	Numbered steps indicate a list of items when the sequence of the items is important, such as the steps listed in a procedure.
■ ■ ■	Bullets indicate a list of items when the sequence of the items is not important.
	The hand points to information that requires special attention.

Visual Cue	Meaning
	The question mark directs you to a software help system with related information.
	The feet direct you to another document or website with related information.
	The multimedia icon directs you to a related multimedia presentation.
 CAUTION	A caution calls attention to a condition or possible situation that can damage or destroy the product or your work.
 WARNING	A warning calls attention to a condition or possible situation that can cause you injury.
	The envelope links to the Email Subscription Management Center page of the Altera website, where you can sign up to receive update notifications for Altera documents.
	The feedback icon allows you to submit feedback to Altera about the document. Methods for collecting feedback vary as appropriate for each document.