

**AAVFIN LIQUID COLD PLATE**

AavFin Liquid Cold Plates extend the surface area by using unique fin structures within the flow path and thereby enhancing heat transfer and thermal performance. AavFin is a cost effective, highly customizable technology that can be configured to engineers' thermal dissipation requirements.

**PART NUMBER**

413100U20609G - Unfinished

**AVAILABLE OPTIONS**

- *Finishes:* AavShield, AavShield<sup>3</sup>, Tin Plate, Electroless Nickel
- *For Custom Sizing and Design Guidelines please see below – Figure 2.*

**AAVFIN PRODUCT SPECIFICATIONS - STANDARD**

<i>Property</i>	<i>Details</i>
<i>Plate Details</i>	Aluminum
<i>Cover Plate</i>	Aluminum
<i>Joints</i>	Vacuum Brazed
<i>Standard Finish</i>	Aavid "Wash" Standard

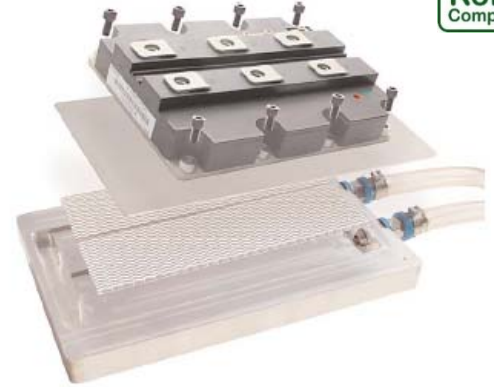

**FEATURES & BENEFITS:**

- Ideal for High Volume, Cost Sensitive Applications
- Leak Free Vacuum Brazed Joints
- Large Liquid Contact Surface Area
- Uniform Heat Transfer

<i>Measurement</i>	<i>in</i>	<i>mm</i>
<i>Plate Width</i>	5.59	142
<i>Plate Length</i>	8.82	224
<i>Plate Thickness</i>	0.71	18.1

**MECHANICAL**

Dimensions are shown in mm

Figure 1

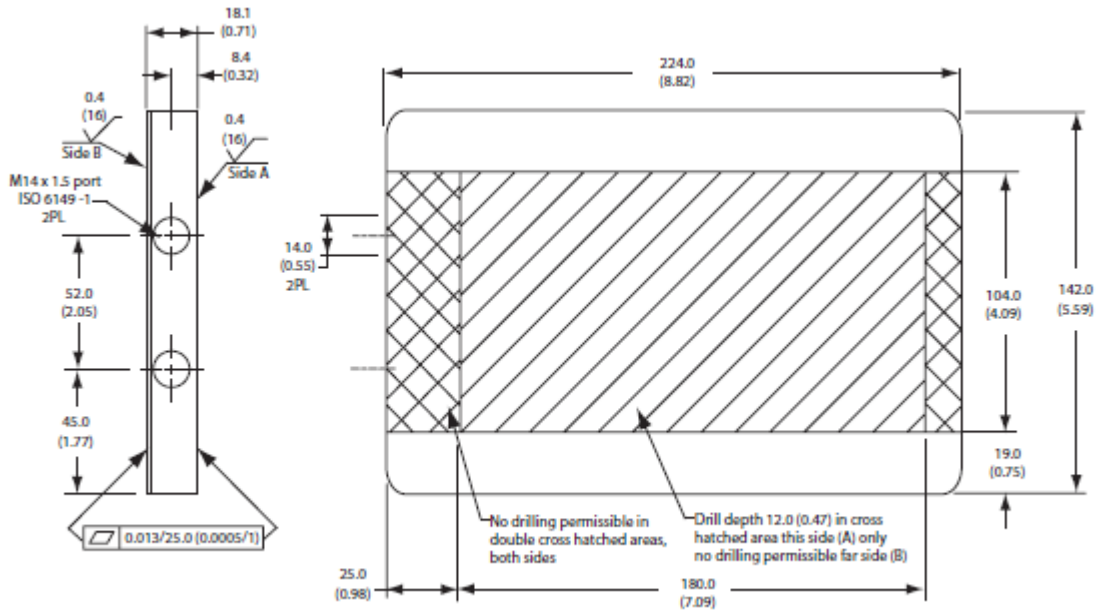

**PERFORMANCE**

Testing was performed using 100% Pure Water

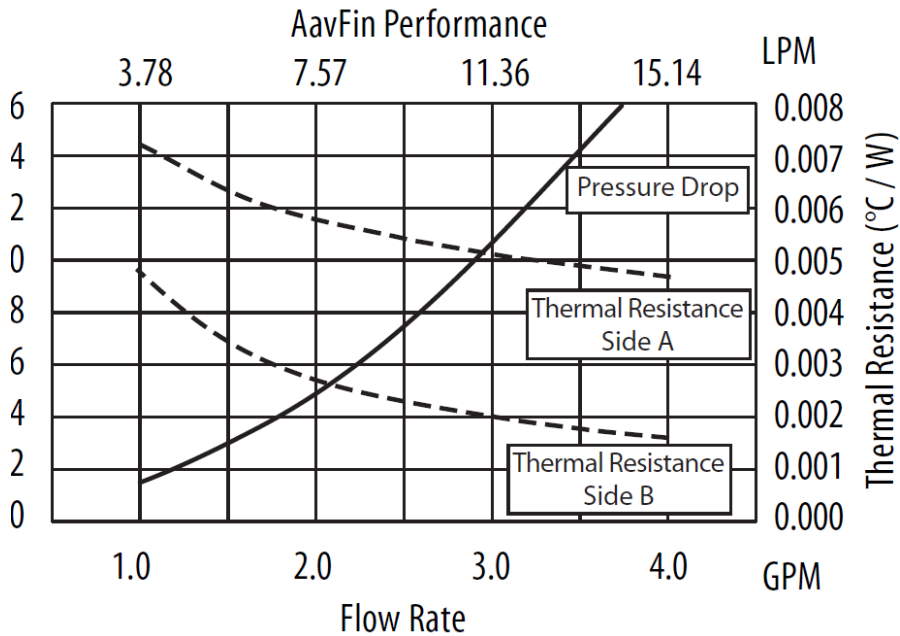

**CUSTOM DESIGN GUIDELINES**

Dimensions are shown in mm

Figure 2

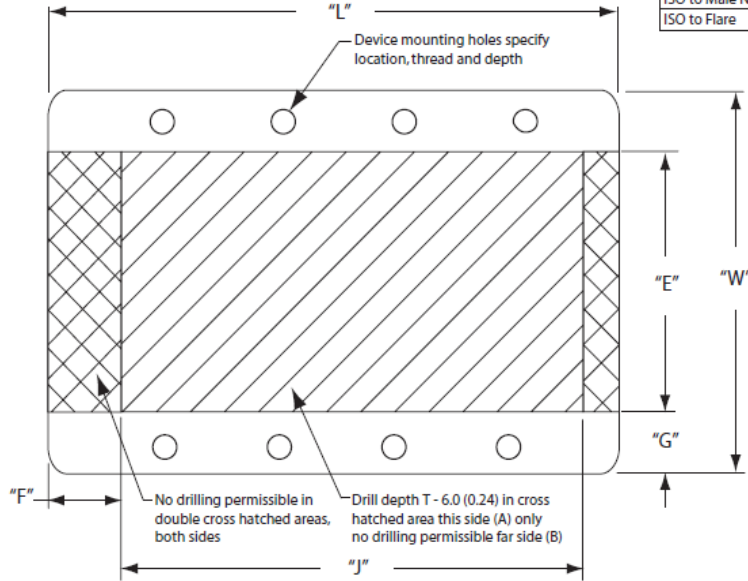
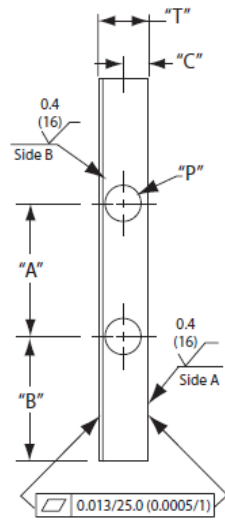

Table 1:  
Available Adapters

ISO to Barb
ISO to Male NPT
ISO to Flare

**Standard Tolerances**

Lead-in Dimensions	± 0.25 (0.01)
Overall Dimensions	± 0.50 (0.02)
Feature to Feature	± 0.13 (0.005)

Dimension	Details	Min	Max
A	Center line, port to port	25 (0.98)	W-P+2.0 (0.08)
B	Edge to port	1/2P+5.0 (0.2)	(W-A)/2
C	Mounting surface to side "A" centerline of port	1/2P+1.0 (0.04)	T-(1/2P+5.0 (0.2))
E	Controlled drill zone width	W-G	W-G
G	Edge to controlled drill zone	6.0 (0.24)	150 (5.91)
T	Plate thickness	12 (0.47)	50 (1.97)
F	No drill zone width	15 (0.59)	30 (1.18)
J	Controlled drill zone length	L-(F+20 (0.8))	L-(F+10 (0.4))
L	Plate length	150 (5.91)	700 (27.56)
P	Port size and thread (metric, pipe, oring)	M8 (1/8 NPT)	T - 5.0 (2.0)
W	Plate width	75 (2.95)	400 (15.75)

Aavid reserves the right to make changes to the products or information contained herein without notice. No liability is assumed as a result of their use or applications. For additional information, please contact Aavid directly.