

STYLE U

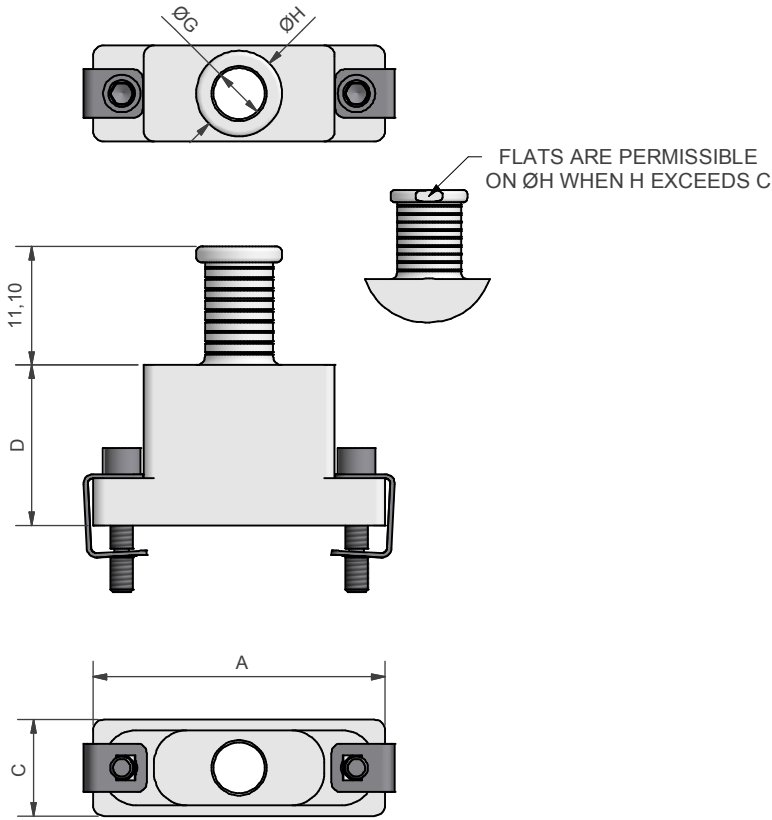

STYLE Z

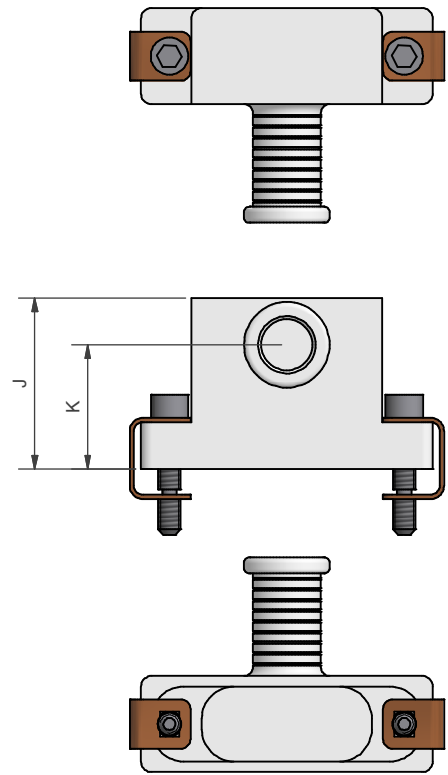

STYLE F

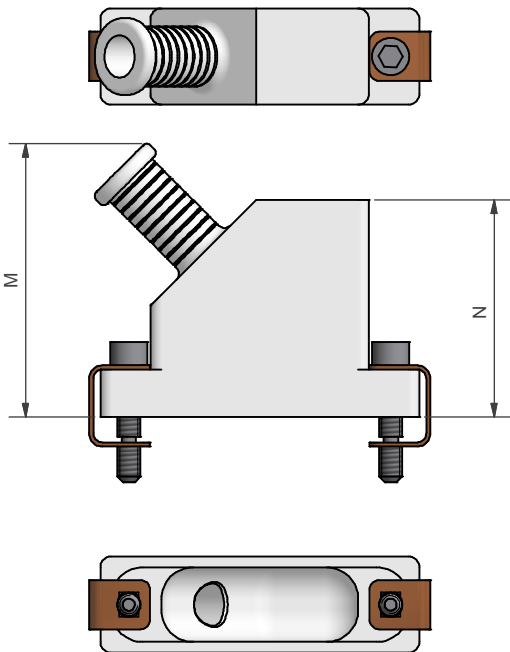

STYLE D

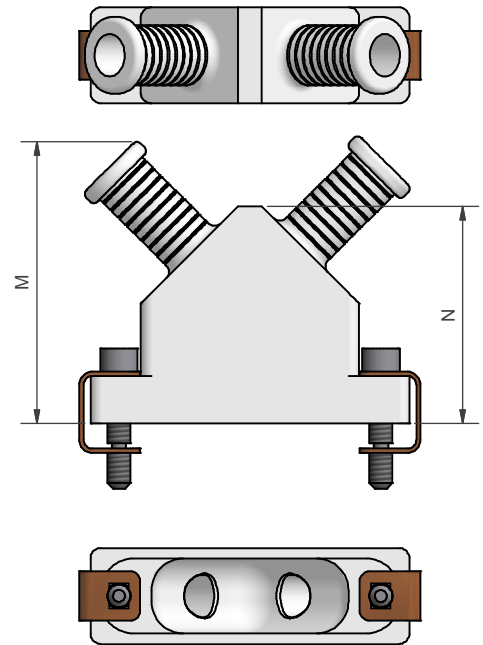

<table border="1"> <tr> <td>DRAWN</td> <td>K.SHEPPARD</td> <td>DATE</td> <td>29/11/2011</td> </tr> <tr> <td>SALES APPR</td> <td>A.POLSON</td> <td>DATE</td> <td>11/11/2011</td> </tr> <tr> <td>DESIGN APPR</td> <td></td> <td></td> <td></td> </tr> <tr> <td>QUAL APPR</td> <td></td> <td></td> <td></td> </tr> <tr> <td>ISSUE</td> <td>REV</td> <td colspan="2">DCR</td> </tr> <tr> <td>6</td> <td>3</td> <td colspan="2"></td> </tr> <tr> <td colspan="2">WEIGHT</td> <td colspan="2">GENERAL TOL LINEAR +/-0.1MM ANGULAR +/- 1°</td> </tr> </table>	DRAWN	K.SHEPPARD	DATE	29/11/2011	SALES APPR	A.POLSON	DATE	11/11/2011	DESIGN APPR				QUAL APPR				ISSUE	REV	DCR		6	3			WEIGHT		GENERAL TOL LINEAR +/-0.1MM ANGULAR +/- 1°		3RD ANGLE PROJECTION NOT TO SCALE	WESTON LOCK LOWER BRISTOL ROAD BATH BA2 1EP	PAGE 1	UNLESS OTHERWISE SPECIFIED ALL DIMENSIONS IN MILLIMETRES
DRAWN	K.SHEPPARD	DATE	29/11/2011																													
SALES APPR	A.POLSON	DATE	11/11/2011																													
DESIGN APPR																																
QUAL APPR																																
ISSUE	REV	DCR																														
6	3																															
WEIGHT		GENERAL TOL LINEAR +/-0.1MM ANGULAR +/- 1°																														
THIS DRAWING IS COPYRIGHT AND THE PROPERTY OF POLAMCO LTD. IT MUST NOT BE COPIED, USED FOR MANUFACTURE OR OTHERWISE DISCLOSED WITHOUT PRIOR WRITTEN CONSENT OF THE COMPANY.		ASSY USED ON: MIL-DTL-83513 TITLE: <h3>BANDING BACKSHELL</h3>		MATERIAL ALUMINIUM ALLOY																												
		PART NUMBER: <h3>RBTMM SERIES</h3>		NCAGE CODE U5792																												
				DRAWING NO: P22259																												

HARDWARE OPTION EK

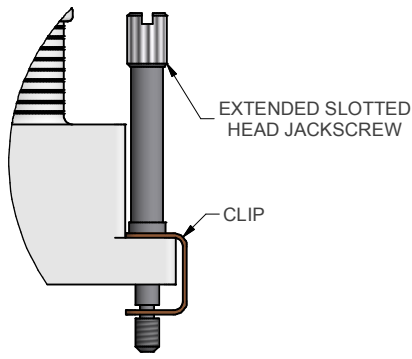

HARDWARE OPTION F

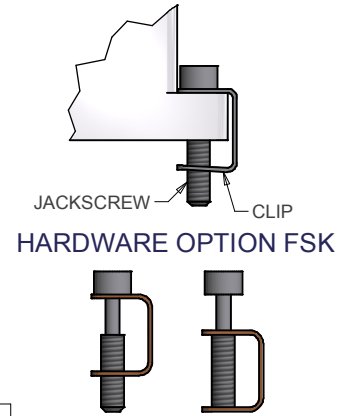
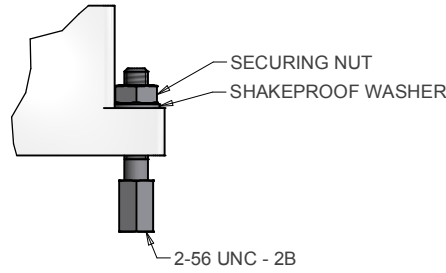

EXAMPLE PART NUMBER: RBTMM-U-21-06-1-C-SL	
RBTMM =	POLAMCO SERIES
U =	ANGLE: U - TOP ENTRY Z - SIDE ENTRY F - 45° ENTRY D - DUAL ENTRY
21 =	SHELL SIZE (TABLE 1)
06 =	ENTRY SIZE (TABLE 2)
1 =	MATERIAL (ALUMINIUM ALLOY)
C =	PLATING (TABLE 3)
SL =	SCREW REF. SL - SLOTTED HEAD JACKSCREW SK - SOCKET HEAD JACKSCREW EK - EXTENDED JACKSCREW F - FEMALE JACKPOST FSK - FLOATING JACKSCREW

SHELL SIZE	A	B	C	D	J MAX	K	M MAX	N	MAX ENTRY STYLES U, F & D	MAX ENTRY STYLE Z
09	19,68	14,35	9,0	9,0	16,2	11,05	25,4	16,5	08	10
15	23,50	18,16	9,0	12,0	17,1	11,20	26,2	17,8	08	12
21	27,30	21,97	9,0	15,0	18,0	11,63	26,7	18,7	08	13
25	29,84	24,51	9,0	16,5	19,0	12,27	27,7	20,3	08	14
31	33,66	28,32	9,0	18,0	19,2	12,09	28,7	21,8	09	15
37	37,46	32,13	9,0	19,0	19,7	12,14	31,2	23,5	09	16
51	36,20	30,86	10,0	19,8	21,8	13,91	31,8	24,8	10	17
69	44,00	38,48	10,0	19,8	21,8	13,91	31,8	24,8	10	17
100	54,86	45,72	11,4	21,3	25,8	17,45	33,5	26,7	12	18

ENTRY SIZE	G MIN	H
04	3,18	6,4
05	3,97	7,2
06	4,77	8,0
07	5,56	8,8
08	6,35	9,6
09	7,14	10,4
10	7,94	11,2
11	8,73	12,0
12	9,52	12,8
13	10,31	13,5
14	11,10	14,3
15	11,89	15,1
16	12,70	15,9
17	13,47	16,7
18	14,26	17,5

STYLE Z ONLY

CODE	PLATING
B	CADMIUM OLIVE DRAB OVER ELECTROLESS NICKEL
C	ELECTROLESS NICKEL
U	UNPLATED
Y	YELLOW CHROMATE OVER CADMIUM
ZB	ZINC COBALT OLIVE DRAB OVER ELECTROLESS NICKEL

LIST NOT EXHAUSTIVE - FOR COMPREHENSIVE LIST AND SPECS SEE WEBSITE

DRAWN	K.SHEPPARD	DATE	29/11/2011	3RD ANGLE PROJECTION NOT TO SCALE	POLAMCO LTD WESTON LOCK LOWER BRISTOL ROAD BATH BA2 1EP	PAGE 2	UNLESS OTHERWISE SPECIFIED ALL DIMENSIONS IN MILLIMETRES
SALES APPR	A.POLSON	DATE	11/11/2011				
DESIGN APPR				THIS DRAWING IS COPYRIGHT AND THE PROPERTY OF POLAMCO LTD IT MUST NOT BE COPIED, USED FOR MANUFACTURE OR OTHERWISE DISCLOSED WITHOUT PRIOR WRITTEN CONSENT OF THE COMPANY.	ASSY USED ON: MIL-DTL-83513	MATERIAL ALUMINIUM ALLOY	NCAGE CODE U5792
QUAL APPR							
ISSUE	6	REV	3				
WEIGHT		GENERAL TOL	LINEAR +/-0.1MM	ANGULAR +/- 1°	PART NUMBER:	RBTMM SERIES	DRAWING NO: P22259