

MATERIAL NUMBER
130060-0083

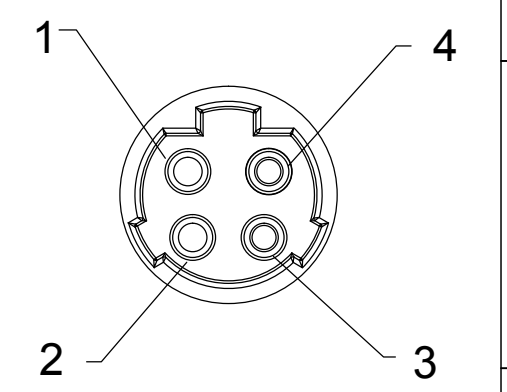
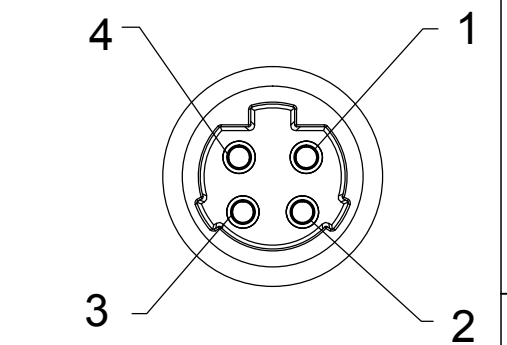
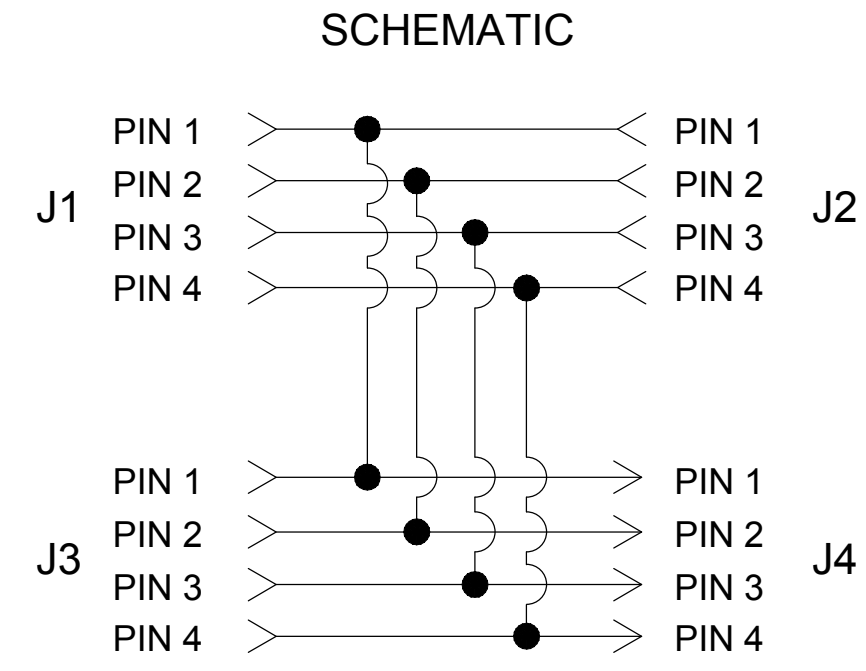
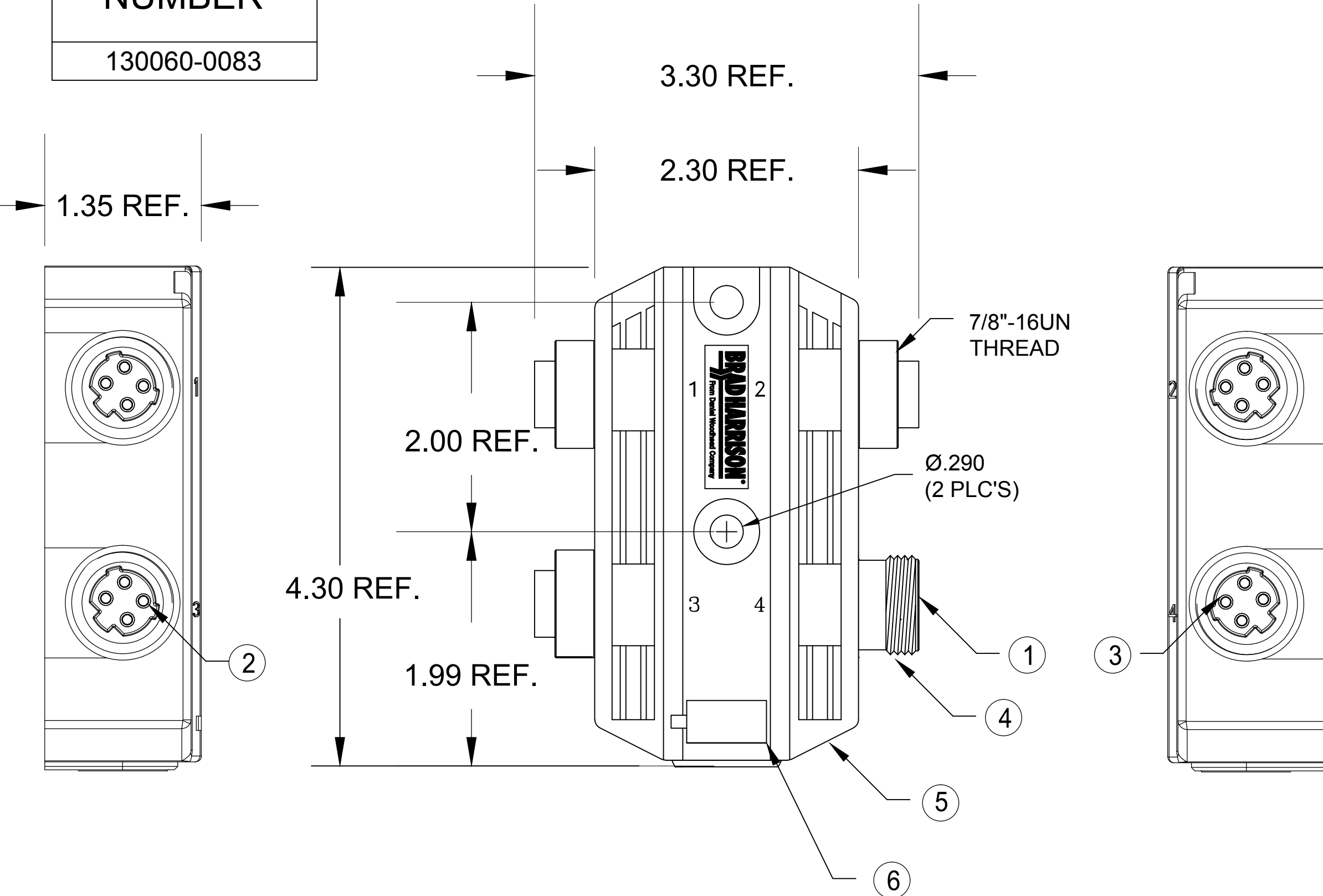

CUSTOMER PRODUCTION APPROVAL
APPROVED BY: _____
DATE: _____
MUST BE SIGNED AND RETURNED BEFORE
PRODUCTION WILL BEGIN.

VOLTAGE RATING	600 VAC/VDC
AMPERAGE RATING	15 AMPS
PROTECTION	IP67
OPERATING TEMPERATURE	0°C TO 60°C

SALES DRAWING

ITEM	COMPONENT	MATERIAL	FINISH
1	INSERT	PVC	BLACK
2	CONTACT SOCKET	COPPER ALLOY	GOLD OVER NICKEL
3	CONTACT PIN	COPPER ALLOY	GOLD OVER NICKEL
4	RECEPTACLE SHELL	ZINC DIE CAST	BLACK E-COATED
5	HOUSING	PBT	BLACK
6	LABEL	ABS	WHITE
	POTTING MATERIAL	EPOXY	BLACK

EC NO: IFCG2013-1470 DRWN: BWOODMAN2013/04/02 CH'KD: KJOZWIK APPR: JFMURPHY 2013/04/25	QUALITY SYMBOL	GENERAL TOLERANCES (UNLESS SPECIFIED)	DIMENSION STYLE	SCALE	DESIGN UNITS	THIRD ANGLE PROJECTION
	▽=0 ∇=0	mm INCH 4 PLACES ±--- ±--- 3 PLACES ±--- ±--- 2 PLACES ±0.05 ±--- 1 PLACE ±0.10 ±---	INCH ONLY	NONE	INCH	
		ANGULAR ±.5°	DRAWN BY DATE	TITLE		
		DRAFT WHERE APPLICABLE MUST REMAIN WITHIN DIMENSIONS	BWOODMAN 2013/04/01	MC 2 PORT PASS-THRU MPIS ALT-KEY 14 AWG		
		CHECKED BY DATE	MATERIAL NO.			
		KJOZWIK 2013/04/09	1300600083			
		APPROVED BY DATE	DOCUMENT NO.			
		JFMURPHY 2013/04/25	SD-130060-015			
			SHEET NO.			
			1 OF 1			
			THIS DRAWING CONTAINS INFORMATION THAT IS PROPRIETARY TO MOLEX INCORPORATED AND SHOULD NOT BE USED WITHOUT WRITTEN PERMISSION			