

24-Bit Analog-to-Digital Converter with One- and Two-Channel Differential Inputs and Internal Oscillator

FEATURES

- **100SPS Data Rate (High-Speed Mode)**
- **Single-Cycle Settling**
- **Easy Conversion Control with START Pin**
- **Automatic Shutdown**
- **Low Noise: $4\mu\text{V}_{\text{RMS}}$ Noise (High-Resolution Mode)**
- **Input Multiplexer with Two Differential Channels (ADS1226)**
- **Voltage Reference Supports Ratiometric Measurements**
- **Self-Calibrating**
- **Simple Read-Only 2-Wire Serial Interface**
- **Internal High-Impedance Input Buffer**
- **Internal Temperature Sensor**
- **Internal Oscillator**
- **Low-Power: 1mW While Operating, $< 1\mu\text{A}$ During Shutdown**
- **Analog and Digital Supplies: 2.7V to 5.5V**

APPLICATIONS

- **Hand-Held Instrumentation**
- **Portable Medical Equipment**
- **Industrial Process Control**

DESCRIPTION

The ADS1225 and ADS1226 are 24-bit delta-sigma analog-to-digital (A/D) converters. They offer excellent performance, ease-of-use, and low power in a small 4mm × 4mm QFN package and are well-suited for demanding high-resolution measurements, especially in portable and other space-saving and power-constrained applications.

The ADS1225 and ADS1226 convert on command using a dedicated START pin. Simply pulse this pin to initiate a conversion. Data is read in a single cycle for retrieval over a 2-wire serial interface that easily connects to popular microcontrollers like the MSP430. After the conversion completes, the ADS1225 and ADS1226 automatically shuts down all circuitry.

Internal features include a two-channel multiplexer (ADS1226), selectable input buffer, temperature sensor, and oscillator. The full-scale range is defined by the external voltage reference with support provided for up to a 5V differential input signal. Two operating modes allow for speed (100SPS data rate, $15\mu\text{V}_{\text{RMS}}$ noise) or resolution ($4\mu\text{V}_{\text{RMS}}$ noise, 16SPS data rate).

The ADS1225/6 supports 2.7 to 5.5V analog and digital supplies. Power consumption is 1mW while converting with 3V supplies. The ADS1225 and ADS1226 are fully specified over an extended industrial temperature range of -40°C to $+105^{\circ}\text{C}$.

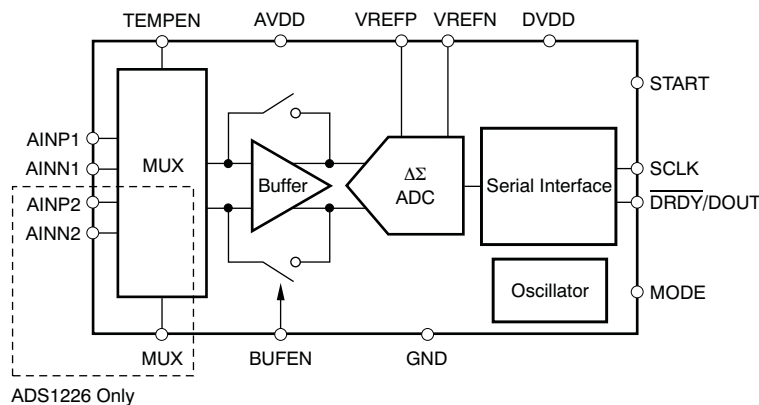

Please be aware that an important notice concerning availability, standard warranty, and use in critical applications of Texas Instruments semiconductor products and disclaimers thereto appears at the end of this data sheet.

All trademarks are the property of their respective owners.



This integrated circuit can be damaged by ESD. Texas Instruments recommends that all integrated circuits be handled with appropriate precautions. Failure to observe proper handling and installation procedures can cause damage.

ESD damage can range from subtle performance degradation to complete device failure. Precision integrated circuits may be more susceptible to damage because very small parametric changes could cause the device not to meet its published specifications.

ORDERING INFORMATION

For the most current package and ordering information, see the Package Option Addendum located at the end of this data sheet or see the TI web site at www.ti.com.

ABSOLUTE MAXIMUM RATINGS⁽¹⁾

Over operating free-air temperature range, unless otherwise noted.

	ADS1225, ADS1226	UNIT
AVDD to GND	–0.3 to +6	V
DVDD to GND	–0.3 to +6	V
Input current	100, momentary	mA
	10, continuous	mA
Analog input voltage to GND	–0.3 to AVDD +0.3	V
Digital input voltage to GND	–0.3 to AVDD +0.3	V
Maximum junction temperature	+150	°C
Operating temperature range	–55 to +125	°C
Storage temperature range	–50 to +150	°C

- (1) Stresses above these ratings may cause permanent damage. Exposure to absolute maximum conditions for extended periods may degrade device reliability. These are stress ratings only, and functional operation of the device at these or any other conditions beyond those specified is not implied.

ELECTRICAL CHARACTERISTICS

All specifications at $T_A = -40^{\circ}\text{C}$ to $+105^{\circ}\text{C}$, $AVDD = +5\text{V}$, $DVDD = +3\text{V}$, and $V_{REF} = +5\text{V}$, unless otherwise noted.

PARAMETER	TEST CONDITIONS	ADS1225, ADS1226			UNIT
		MIN	TYP	MAX	
Analog Input					
Full-scale input voltage	AINP – AINN	$\pm V_{REF}$			V
Absolute input voltage	Buffer off; AINP, AINN with respect to GND	GND – 0.1	AVDD + 0.1		V
	Buffer on; AINP, AINN with respect to GND	GND + 0.05	AVDD – 1.5		V
Differential input impedance	Buffer off	2			M Ω
	Buffer on	1			G Ω
Common-mode input impedance	Buffer off	4			M Ω
System Performance					
Resolution		24			Bits
Data rate	High-Speed mode	75	100	125	SPS ⁽¹⁾
	High-Resolution mode	12	16	22	SPS ⁽¹⁾
Integral nonlinearity (INL)	End-point fit	0.0005		0.0020	% of FSR ⁽²⁾
Offset error		60		200	μV
Offset error drift		0.3			$\mu\text{V}/^{\circ}\text{C}$
Gain error		0.004		0.025	%
Gain error drift		0.3			ppm/ $^{\circ}\text{C}$
Common-mode rejection	At dc	85	95		dB
Analog power-supply rejection	At dc, $\pm 10\%$ Δ in AVDD	95			dB
Digital power-supply rejection	At dc, DVDD = 2.7V to 5.5V	80			dB
Noise	High-Speed mode	1.5			ppm of FSR, rms
	High-Resolution mode	0.4			ppm of FSR, rms
Temperature Sensor					
Temperature sensor voltage	$T_A = +25^{\circ}\text{C}$	106			mV
Temperature sensor coefficient		360			$\mu\text{V}/^{\circ}\text{C}$
Voltage Reference Input					
Reference input voltage	$V_{REF} = V_{REFP} - V_{REFN}$	0.5	AVDD		V
Negative reference input		GND – 0.1	$V_{REFP} - 0.5$		V
Positive reference input		$V_{REFN} + 0.5$	AVDD + 0.1		V
Voltage reference impedance		1.5			M Ω

(1) SPS = samples per second.

(2) FSR = full-scale range = $2 \times V_{REF}$.

ELECTRICAL CHARACTERISTICS (continued)

All specifications at $T_A = -40^{\circ}\text{C}$ to $+105^{\circ}\text{C}$, $\text{AVDD} = +5\text{V}$, $\text{DVDD} = +3\text{V}$, and $V_{\text{REF}} = +5\text{V}$, unless otherwise noted.

PARAMETER	TEST CONDITIONS	ADS1225, ADS1226			UNIT
		MIN	TYP	MAX	
Digital Input/Output					
Logic levels	V_{IH}		0.8 DVDD	DVDD + 0.1	V
	V_{IL}		GND – 0.1	0.2 DVDD	V
	V_{OH}	$I_{\text{OH}} = 1\text{mA}$	0.8 DVDD		V
	V_{OL}	$I_{\text{OL}} = 1\text{mA}$		0.2 DVDD	V
Input leakage				±10	μA
Power Supply					
AVDD		2.7		5.5	V
DVDD		2.7		5.5	V
AVDD current	Shutdown		< 1		μA
	AVDD = 5V, converting, buffer off		285		μA
	AVDD = 5V, converting, buffer on		405		μA
	AVDD = 3V, converting, buffer off		265		μA
	AVDD = 3V, converting, buffer on		385		μA
DVDD current	Shutdown		< 1		μA
	DVDD = 5V, converting		90		μA
	DVDD = 3V, converting		55		μA
Total power dissipation	AVDD = 5V, DVDD = 3V, buffer off		1.6	2.5	mW
	AVDD = DVDD = 3V, buffer off		1		mW
Temperature Range					
Specified		–40		+105	°C
Operating		–55		+125	°C
Storage		–60		+150	°C

PIN CONFIGURATION

RGV PACKAGE
QFN-16, 4.0mm × 4.0mm
(TOP VIEW)

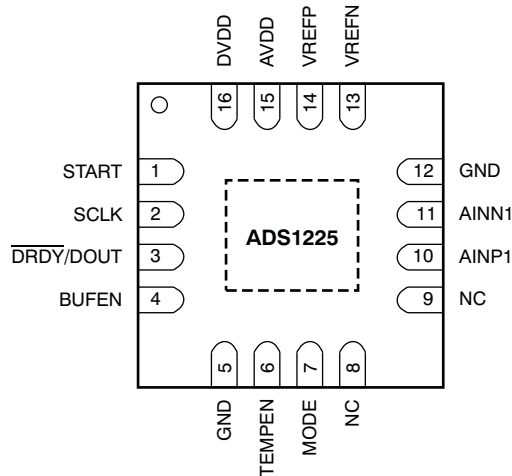

PIN DESCRIPTIONS—ADS1225

TERMINAL		ANALOG/DIGITAL INPUT/OUTPUT	DESCRIPTION
NAME	NO.		
START	1	Digital Input	High: Start conversions; Low: Shutdown
SCLK	2	Digital Input	Serial clock input
$\overline{\text{DRDY}}/\text{DOUT}$	3	Digital Output	Dual-purpose output: Data ready: indicates valid data by going low. Data output: outputs data, MSB first, on the rising edge of SCLK.
BUFEN	4	Digital Input	Enables buffer after MUX
GND	5	Ground	Analog and digital ground
TEMPEN	6	Digital Input	Selects temperature sensor input from MUX
MODE	7	Digital Input	Selects between High-Speed and High-Resolution modes
NC	8		No connect
NC	9		No connect
AINP1	10	Analog Input	Analog channel 1 positive input
AINN1	11	Analog Input	Analog channel 1 negative input
GND	12	Ground	Analog and digital ground
VREFN	13	Analog Input	Negative reference input
VREFP	14	Analog Input	Positive reference input
AVDD	15	Analog	Analog power supply
DVDD	16	Digital	Digital power supply

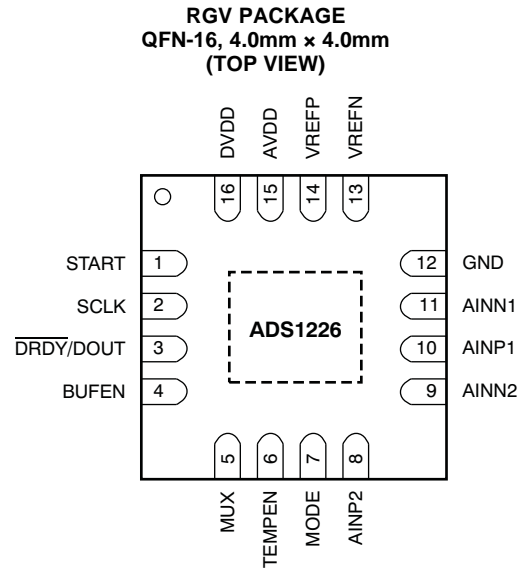

PIN DESCRIPTIONS—ADS1226

TERMINAL		ANALOG/DIGITAL INPUT/OUTPUT	DESCRIPTION
NAME	NO.		
START	1	Digital Input	High: Start conversions; Low: Shutdown
SCLK	2	Digital Input	Serial clock input
$\overline{\text{DRDY}}/\text{DOUT}$	3	Digital Output	Dual-purpose output: Data ready: indicates valid data by going low. Data output: outputs data, MSB first, on the rising edge of SCLK.
BUFEN	4	Digital Input	Enables buffer after MUX
MUX	5	Digital Input	Selects analog input from MUX
TEMPEN	6	Digital Input	Selects temperature sensor input from MUX
MODE	7	Digital Input	Selects between High-Speed and High-Resolution modes
AINP2	8	Analog Input	Analog channel 2 positive input
AINN2	9	Analog Input	Analog channel 2 negative input
AINP1	10	Analog Input	Analog channel 1 positive input
AINN1	11	Analog Input	Analog channel 1 negative input
GND	12	Ground	Analog and digital ground
VREFN	13	Analog Input	Negative reference input
VREFP	14	Analog Input	Positive reference input
AVDD	15	Analog	Analog power supply
DVDD	16	Digital	Digital power supply

TYPICAL CHARACTERISTICS

At $T_A = +25^\circ\text{C}$, $AVDD = +5\text{V}$, $DVDD = +3\text{V}$, and $V_{REF} = +5\text{V}$, unless otherwise noted.

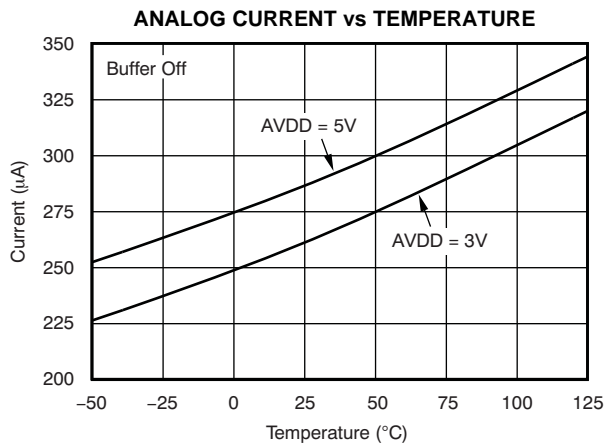

Figure 1.

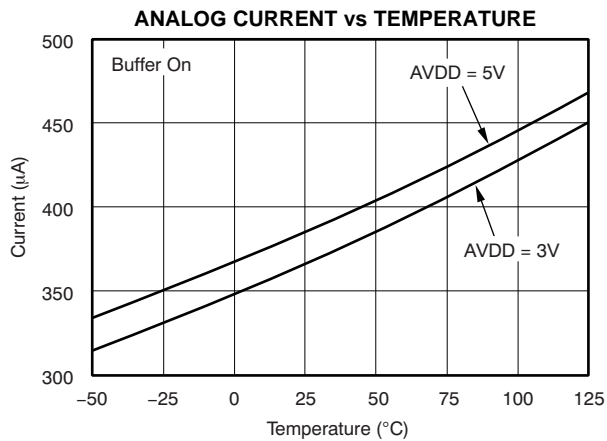

Figure 2.

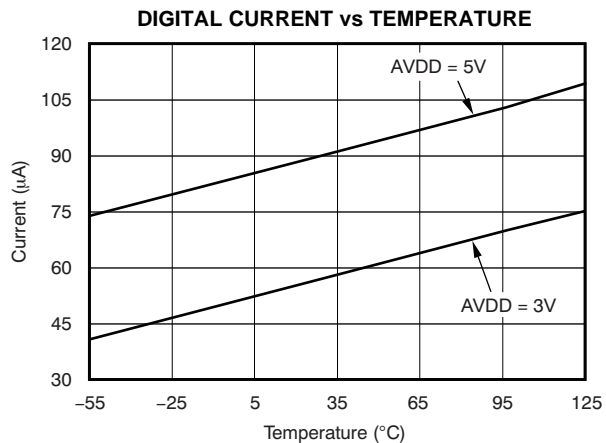

Figure 3.

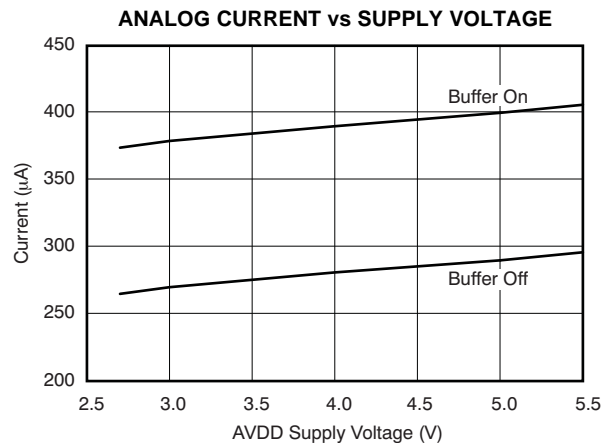

Figure 4.

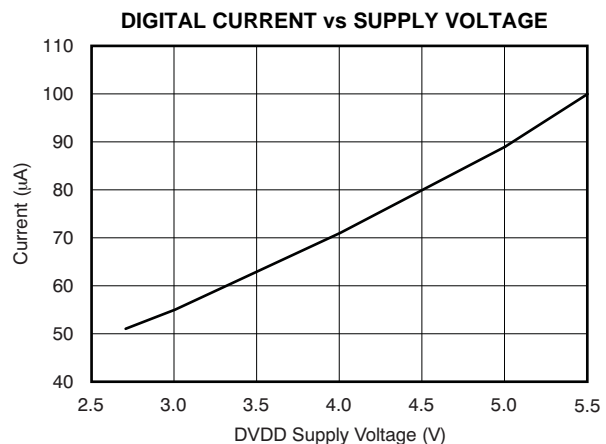

Figure 5.

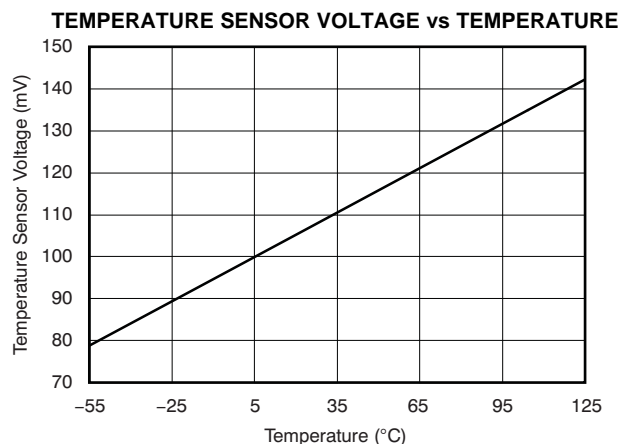

Figure 6.

TYPICAL CHARACTERISTICS (continued)

At $T_A = +25^\circ\text{C}$, $AV_{DD} = +5\text{V}$, $DV_{DD} = +3\text{V}$, and $V_{REF} = +5\text{V}$, unless otherwise noted.

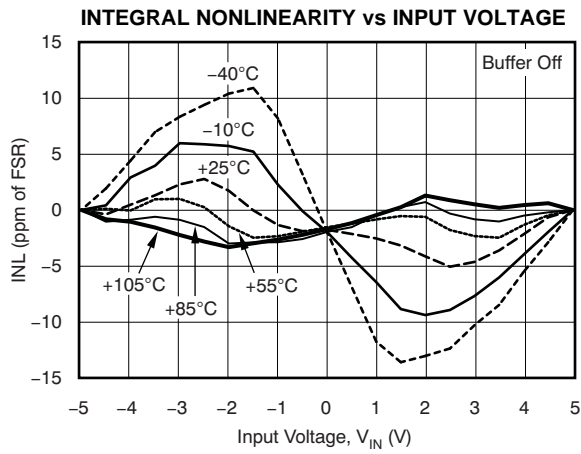

Figure 7.

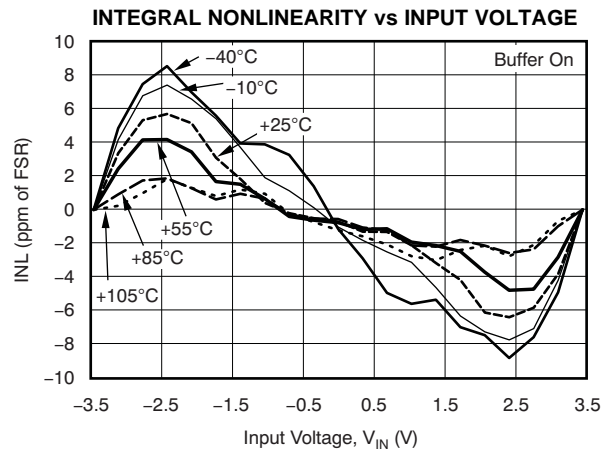

Figure 8.

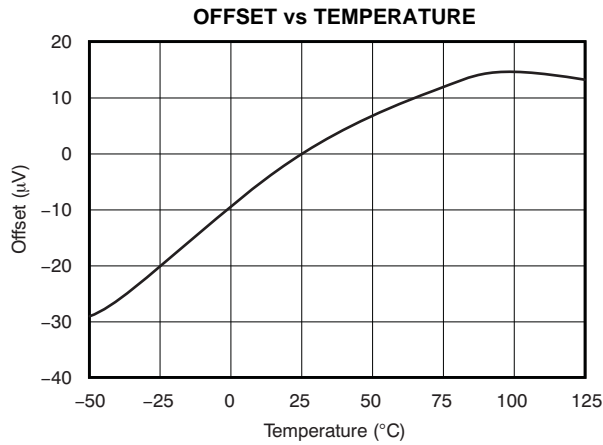

Figure 9.

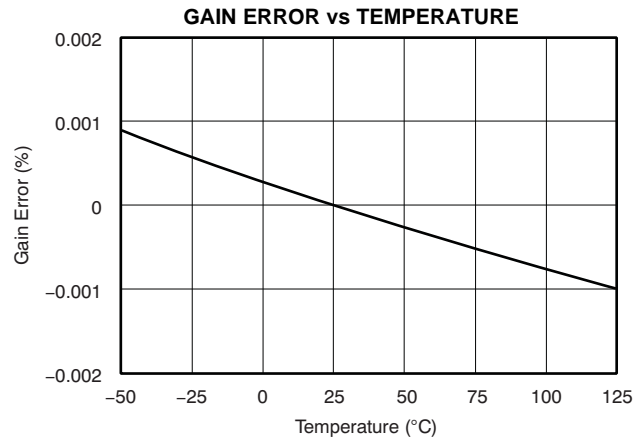

Figure 10.

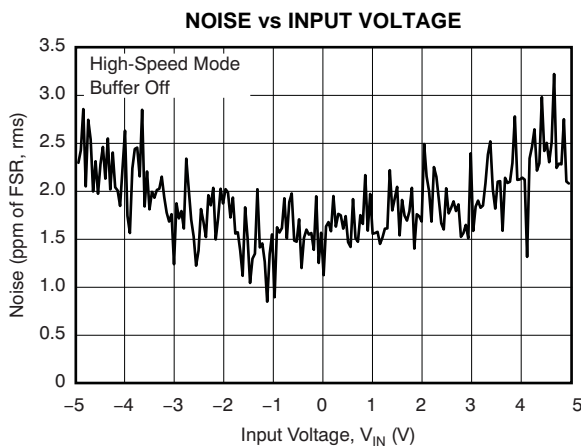

Figure 11.

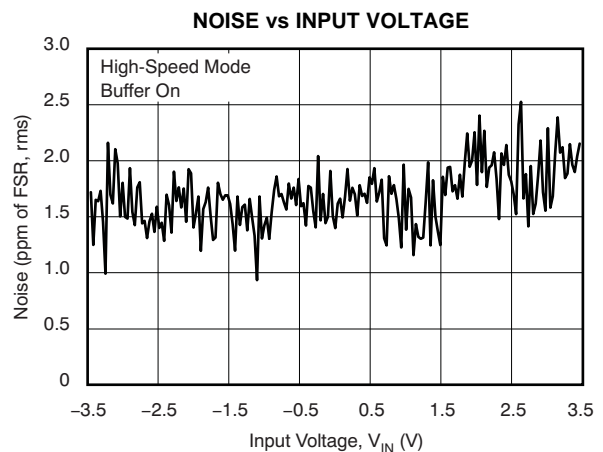

Figure 12.

TYPICAL CHARACTERISTICS (continued)

At $T_A = +25^\circ\text{C}$, $AVDD = +5\text{V}$, $DVDD = +3\text{V}$, and $V_{REF} = +5\text{V}$, unless otherwise noted.

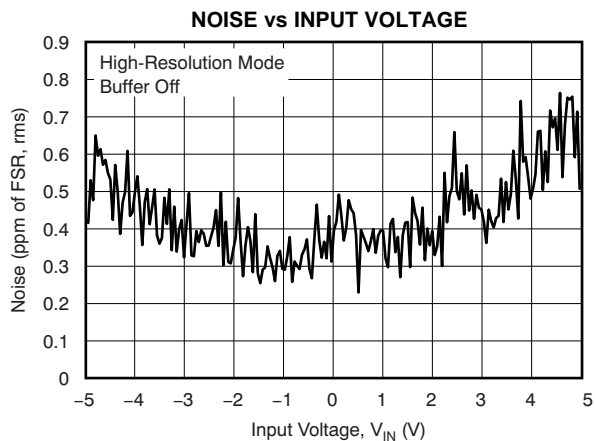

Figure 13.

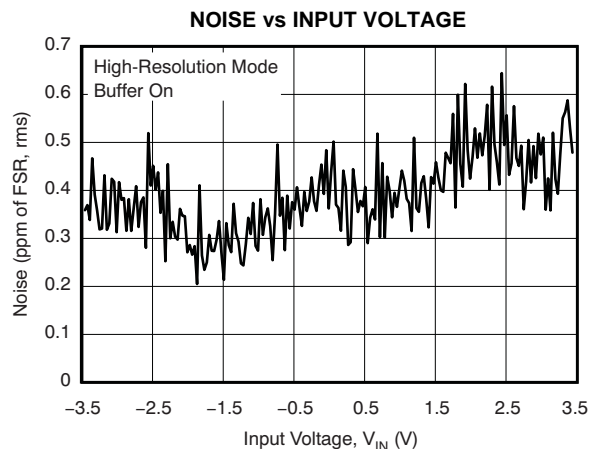

Figure 14.

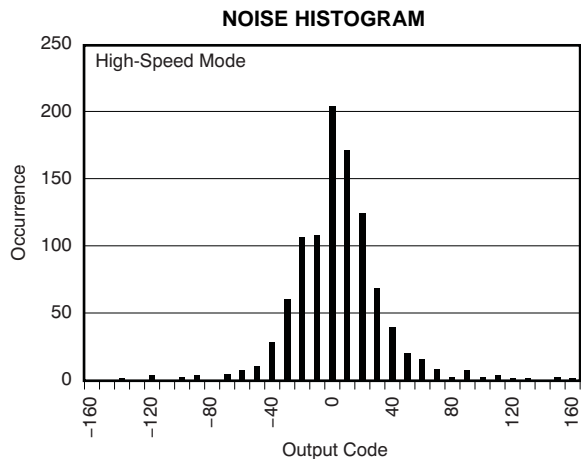

Figure 15.

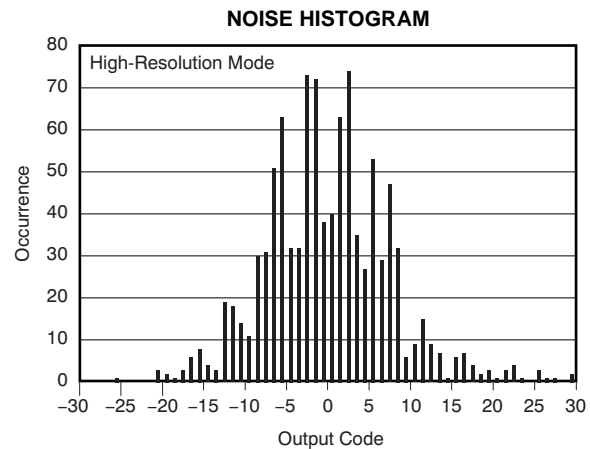

Figure 16.

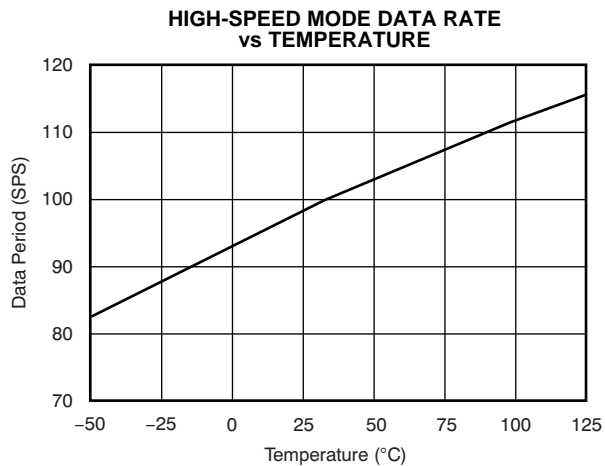

Figure 17.

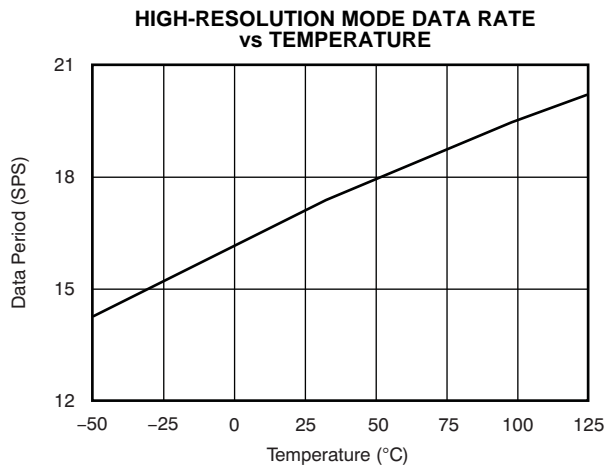

Figure 18.

OVERVIEW

The ADS1225 and ADS1226 are 24-bit delta-sigma A/D converters. Figure 19 shows a conceptual diagram of the device. The ADS1225 has a single channel, while the ADS1226 allows for one of two input channels to be selected through a multiplexer. A buffer can also be selected to increase the input impedance. The modulator measures the differential input signal $V_{IN} = (AINP - AINN)$ against the differential reference $V_{REF} = (VREFP - VREFN)$. The full-scale input range is $\pm V_{REF}$. A 2-wire serial interface indicates conversion completion and provides the user with the output data. An internal oscillator allows for free-running of the ADS1225 and ADS1226.

Two other pins are used to control the operation of the ADS1225 and ADS1226. The START pin initiates conversions. The MODE pin puts the device into one of two modes. In High-Speed mode, the device gives data at 100 samples per second (SPS). In High-Resolution mode, data comes out at 16SPS with lower noise. In both modes, the device has single-cycle settling, reducing the latency of the output data.

ANALOG INPUTS (AINx+, AINx-)

The input signal to be measured is applied to the input pins AINPx and AINNx. The positive internal input is generalized as AINP, and the negative internal input is generalized as AINN. The signal is selected through the input MUX, which is controlled by MUX, as shown in Table 1. The ADS1225 and ADS1226 accept differential input signals, but can also measure unipolar signals. When measuring unipolar (or single-ended) signals with respect to ground, connect the negative input (AINN) to ground and connect the input signal to the positive input (AINP). Note that when the ADS1225 and ADS1226 are configured this way, only half of the converter full-scale range is used since only positive digital output codes are produced. An input buffer can be selected to increase the input impedance of the A/D converter with the BUFEN pin.

Table 1. Input Channel Selection with MUX

DIGITAL PIN	SELECTED ANALOG INPUTS	
MUX	POSITIVE INPUT	NEGATIVE INPUT
0	AINP1	AINN1
1	AINP2	AINN2

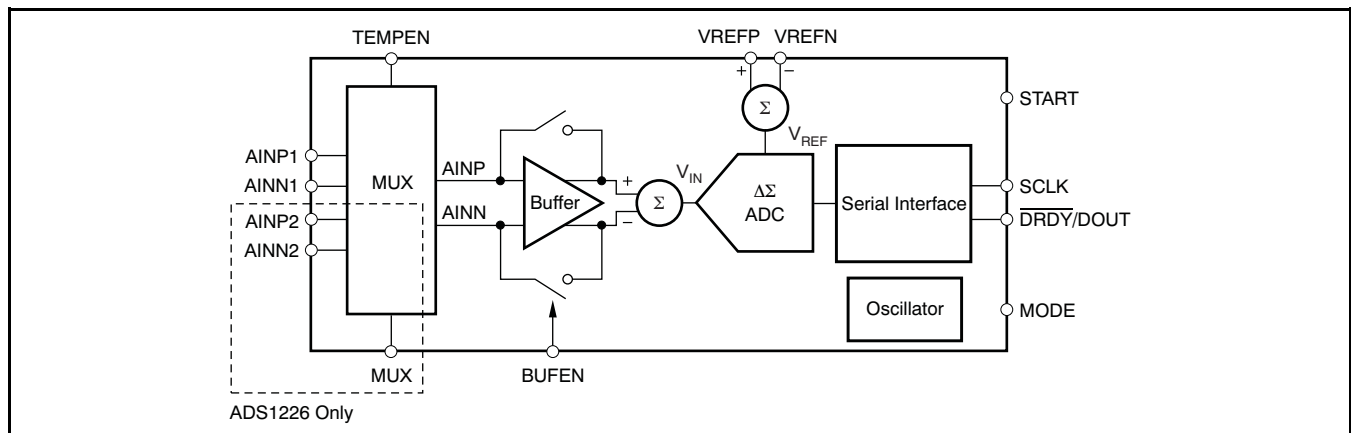

Figure 19. Conceptual Diagram of the ADS1225 and ADS1226

Analog Input Measurement Without the Input Buffer

With the buffer disabled by setting the BUFEN pin low, the ADS1225 and ADS1226 measure the input signal using internal capacitors that are continuously charged and discharged. Figure 20 shows a simplified schematic of the ADS1225/6 input circuitry, with Figure 21 showing the on/off timings of the switches. The S_1 switches close during the input sampling phase. With S_1 closed, C_{A1} charges to AINP, C_{A2} charges to AINN, and C_B charges to (AINP – AINN). For the discharge phase, S_1 opens first and then S_2 closes. C_{A1} and C_{A2} discharge to approximately VDD/2 and C_B discharges to 0V. The constant charging of the input capacitors presents a load on the inputs that can be represented by effective impedances. Figure 22 shows the input circuitry with the capacitors and switches of Figure 20 by their effective impedances.

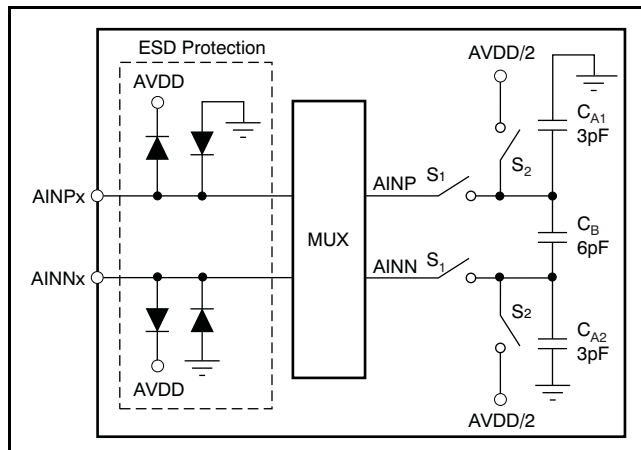

Figure 20. Simplified Input Structure with the Buffer Turned Off

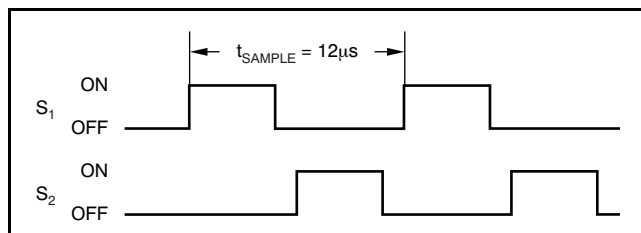

Figure 21. S_1 and S_2 Switch Timing for Figure 20

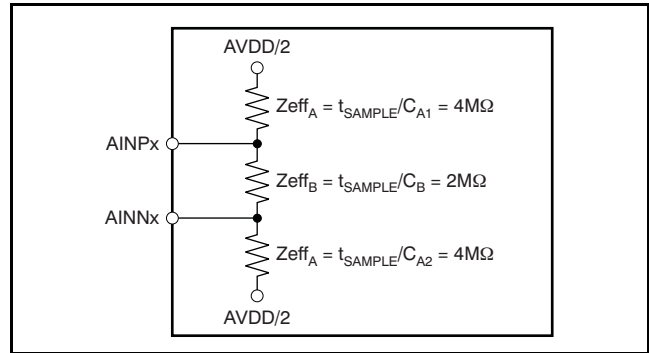

Figure 22. Effective Analog Input Impedances with the Buffer Off

ESD diodes protect the inputs. To keep these diodes from turning on, make sure the voltages on the input pins do not go below GND by more than 100mV, and likewise do not exceed VDD by 100mV. This limitation is shown in Equation 1:

$$GND - 100mV < (AINP, AINN) < VDD + 100mV \quad (1)$$

Analog Input Measurement with the Input Buffer

When the buffer is enabled by setting the BUFEN pin high, a low-drift, chopper-stabilized input buffer is used to achieve very high input impedance. The buffer charges the input sampling capacitors, thus removing the load from the measurement. Because the input buffer is chopper-stabilized, the charging of parasitic capacitances causes the charge to be carried away, as if by resistance. The input impedance can be modeled by a single resistor, as shown in Figure 23. Note that when START is low, the buffer must be disabled to prevent loading of the inputs.

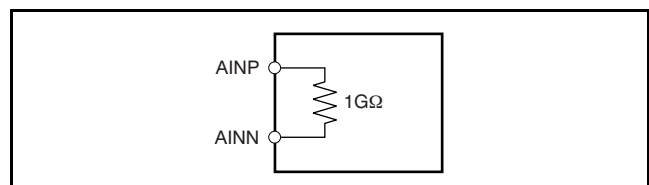

Figure 23. Effective Analog Input Impedances with the Buffer On

Note also that the analog inputs (listed in the Electrical Characteristics table as *Absolute Input Range*) must remain between GND + 0.05V to AVDD – 1.5V. Exceeding this range degrades linearity and results in performance outside the specified limits.

TEMPERATURE SENSOR

Internal diodes provide temperature-sensing capability. By setting the TEMPEN pin high, the selected analog inputs are disconnected and the inputs to the A/D converter are connected to the anodes of two diodes scaled to 1x and 64x in current and size inside the MUX, as shown in Figure 24. By measuring the difference in voltage of these diodes, temperature changes can be inferred from a baseline temperature. Typically, the difference in diode voltages is 106mV at +25°C, with a temperature coefficient of 360μV/°C. A similar structure is used in the MSC1210 for temperature measurement. For more information, see TI application report SBAA100, *Using the MSC121x as a High-Precision Intelligent Temperature Sensor*, available for download at www.ti.com.

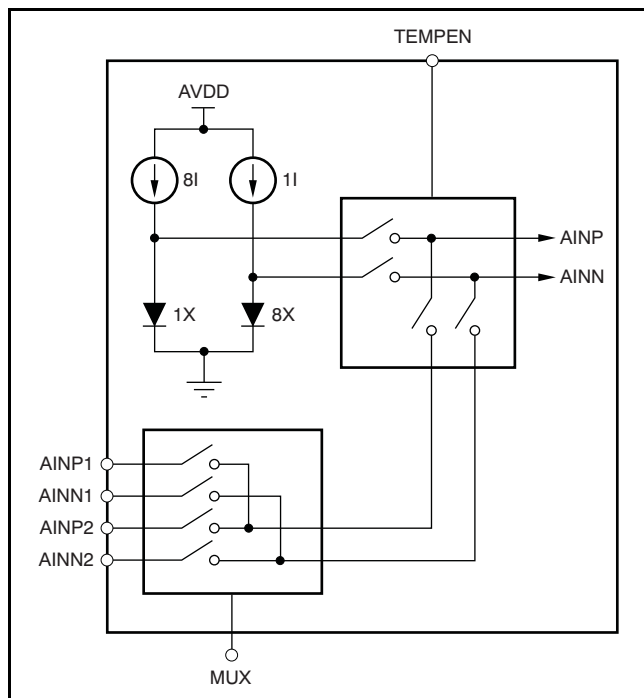

Figure 24. Measurement of the Temperature Sensor in the Input

VOLTAGE REFERENCE INPUTS (VREFP, VREFN)

The voltage reference used by the modulator is generated from the voltage difference between VREFP and VREFN: $V_{REF} = VREFP - VREFN$. The reference inputs use a structure similar to that of the analog inputs. A simplified diagram of the circuitry on the reference inputs is shown in Figure 25. The switches and capacitors can be modeled with an effective impedance of 1.5MΩ.

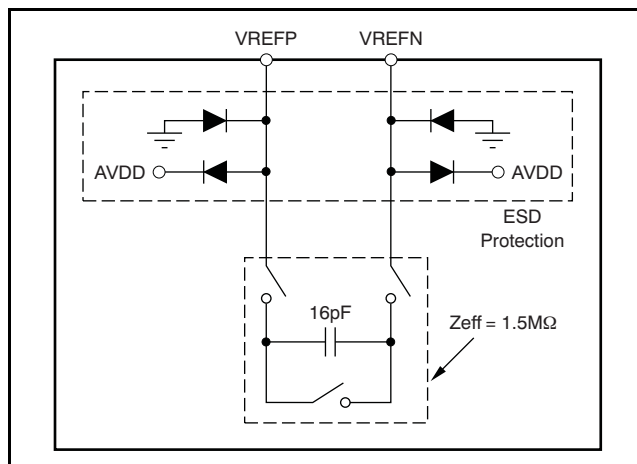

Figure 25. Simplified Reference Input Circuitry

ESD diodes protect the reference inputs. To prevent these diodes from turning on, make sure the voltages on the reference pins do not go below GND by more than 100mV, and likewise, do not exceed VDD by 100mV. This limitation is shown in Equation 2:

$$GND - 100mV < (VREFP, VREFN) < VDD + 100mV \quad (2)$$

For best performance, bypass the voltage reference inputs with a 0.1μF capacitor between VREFP and VREFN. Place the capacitor as close as possible to the pins.

The differential voltage reference inputs and the wide range of operation (V_{REF} can support up to AVDD) make ratiometric measurements easy to implement.

INTERNAL OSCILLATOR

The ADS1225 and ADS1226 have an internal oscillator and run without an external crystal or oscillator.

DATA READY/DATA OUTPUT ($\overline{\text{DRDY}}/\text{DOUT}$)

This digital output pin serves two purposes. First, it indicates when new data is ready by going LOW. Afterwards, on the first rising edge of SCLK, the $\overline{\text{DRDY}}/\text{DOUT}$ pin changes function and begins to output the conversion data, most significant bit (MSB) first. Data is shifted out on each subsequent SCLK rising edge. After all 24 bits have been retrieved, the pin can be forced high with an additional SCLK. It then stays high until new data is ready. This configuration is useful when polling on the status of $\overline{\text{DRDY}}/\text{DOUT}$ to determine when to begin data retrieval.

SERIAL CLOCK INPUT (SCLK)

This digital input shifts serial data out with each rising edge. There is hysteresis built into this input, but care should still be taken to ensure a clean signal. Glitches or slow-rising signals can cause unwanted additional shifting. For this reason, it is best to make sure the rise-and-fall times of SCLK are less than 50ns.

MODE

The ADS1225 and ADS1226 have two modes of operation, allowing for High-Speed or High-Resolution. By taking the MODE pin high, the data rate is approximately 100Hz with an rms noise of 15 μ V. When the MODE pin is low, the ADS1225 and ADS1226 average multiple samples to increase the noise performance to 4 μ V of rms noise with a data rate of 16Hz. Table 2 shows the MODE pin operation.

Table 2. MODE Pin Operation for the ADS1225 and ADS1226

MODE PIN	MODE	DATA RATE	NOISE
0	High-Resolution	16SPS	4 μ Vrms
1	High-Speed	100SPS	15 μ Vrms

START

The START pin provides easy and precise control of conversions. Pulse the START pin high to begin a conversion as shown in Figure 26 and Table 3. The completion of the conversion is indicated by the $\overline{\text{DRDY}}/\text{DOUT}$ pin going low. Once the conversion completes, the ADS1225 and ADS1226 automatically shut down to save power. They stay shut down until START is once again taken high to begin a new conversion.

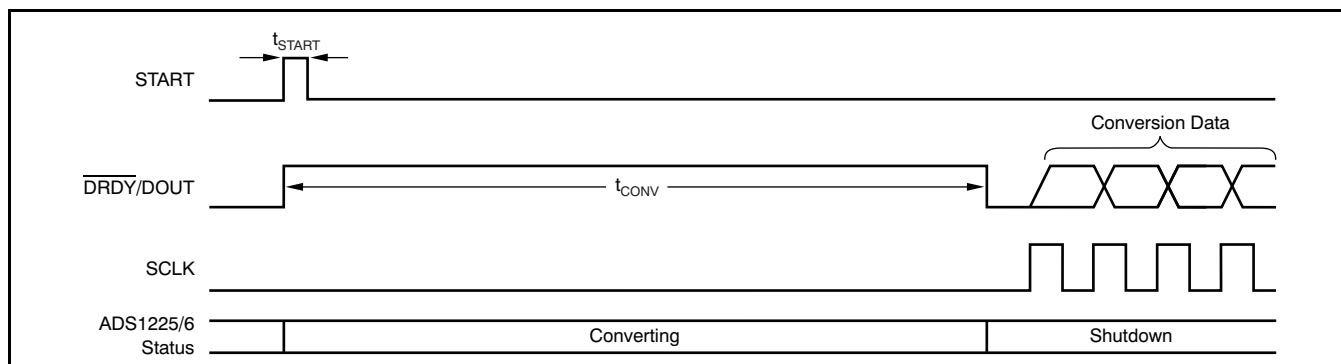

Figure 26. Controlling Conversion with the START Pin

Table 3. START Pin Conversion Times for Figure 26

SYMBOL	DESCRIPTION	MIN	MAX	UNITS
t_{START}	Minimum START pulse to initiate a conversion	17		μ s
t_{CONV}	Conversion time High-Speed mode	8.0	13.3	ms
	Conversion time High-Resolution mode	45.5	83.3	ms

The ADS1225 and ADS1226 can be configured to continuously convert by holding the START pin high as shown in Figure 27. With START held high, a new conversion starts immediately after the previous conversion completes. This configuration continues until the START pin is taken low. During calibration, the START pin must be kept high. Refer to the [Self-Calibration](#) section for details. Note that when START is low, the buffer must be disabled to prevent loading of the inputs.

DATA FORMAT

The ADS1225 and ADS1226 output 24 bits of data in binary two's complement format. The least significant bit (LSB) has a weight of $(V_{REF})/(2^{23} - 1)$. The positive full-scale input produces an output code of 7FFFFFFh and the negative full-scale input produces an output code of 800000h. The output clips at these codes for signals exceeding full-scale. Table 4 summarizes the ideal output codes for different input signals.

Table 4. Ideal Output Code vs Input Signal

Input Signal V_{IN} (AINP – AINN)	IDEAL OUTPUT CODE ⁽¹⁾
$\geq +V_{REF}$	7FFFFFFh
$\frac{+V_{REF}}{2^{23} - 1}$	000001h
0	000000h
$\frac{-V_{REF}}{2^{23} - 1}$	FFFFFFh
$\leq -V_{REF}$	800000h

(1) Excludes effects of noise, INL, offset, and gain errors.

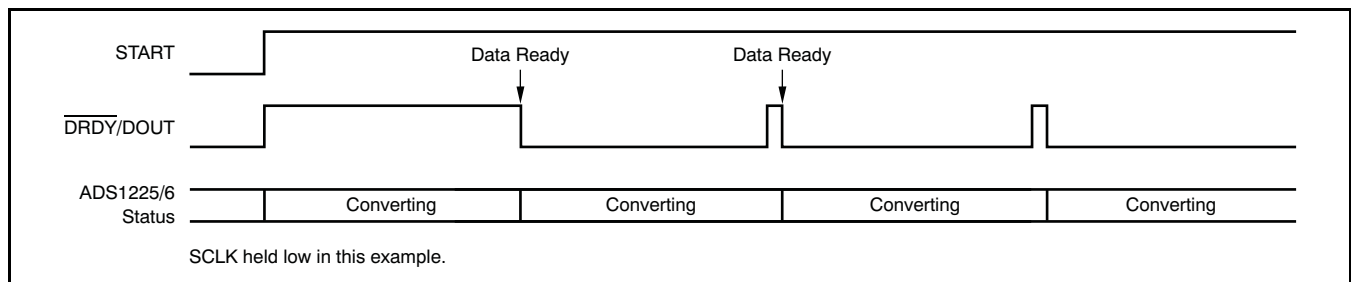

Figure 27. Conversion with the START Pin High

DATA RETRIEVAL

With the START pin high, the ADS1225 and ADS1226 continuously convert the analog input signal. To retrieve data, wait until $\overline{\text{DRDY}}/\text{DOUT}$ goes low, as illustrated in Figure 28 and Table 5. After this occurs, begin shifting out the data by applying SCLKs. Data is shifted out MSB first. It is not required to shift out all 24 bits of data, but the data must be retrieved before the new data is updated (see t_2) or else it will be overwritten.

Avoid data retrieval during the update period. $\overline{\text{DRDY}}/\text{DOUT}$ remain at the state of the last bit shifted out until it is taken high (see t_6), indicating that new data is being updated. To avoid having $\overline{\text{DRDY}}/\text{DOUT}$ remain in the state of the last bit, shift a 25th SCLK to force $\overline{\text{DRDY}}/\text{DOUT}$ high (refer to Figure 29). This technique is useful when a host controlling the ADS1225 and ADS1226 is polling $\overline{\text{DRDY}}/\text{DOUT}$ to determine when data is ready.

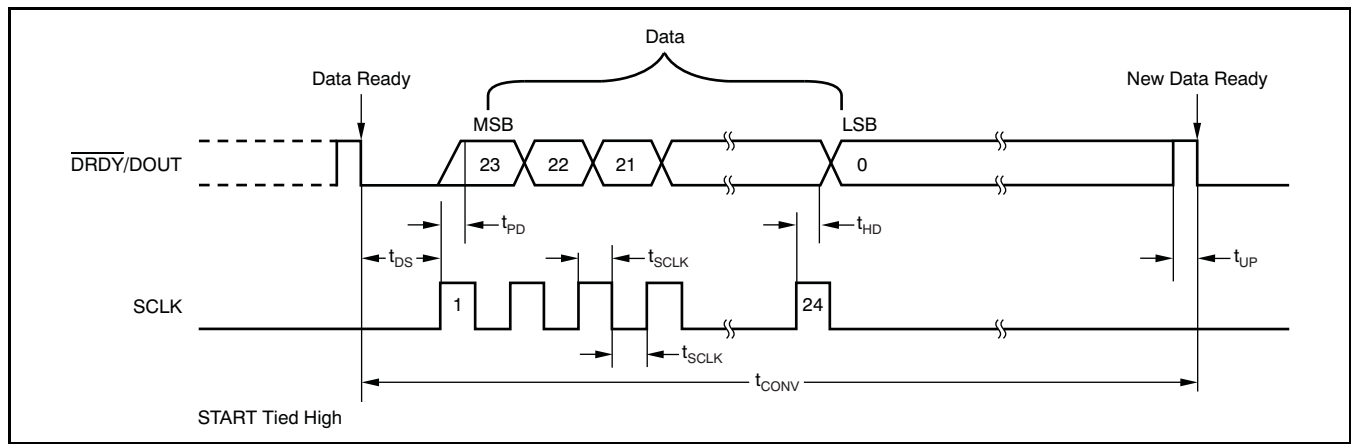

Figure 28. Data Retrieval Timing

Table 5. Data Retrieval Times for Figure 28

SYMBOL	DESCRIPTION	MIN	MAX	UNITS
t_{DS}	$\overline{\text{DRDY}}/\text{DOUT}$ low to first SCLK rising edge	0		ns
t_{SCLK}	SCLK positive or negative pulse width	100		ns
t_{PD}	SCLK rising edge to new data bit valid: propagation delay		50	ns
t_{HD}	SCLK rising edge to old data bit valid: hold time	0		ns
t_{UP}	Data updating: no readback allowed	29.5	49.2	μs
t_{CONV}	Conversion time (1/data rate), High-Speed mode	8.0	13.3	ms
	Conversion time (1/data rate), High-Resolution mode	45.5	83.3	ms

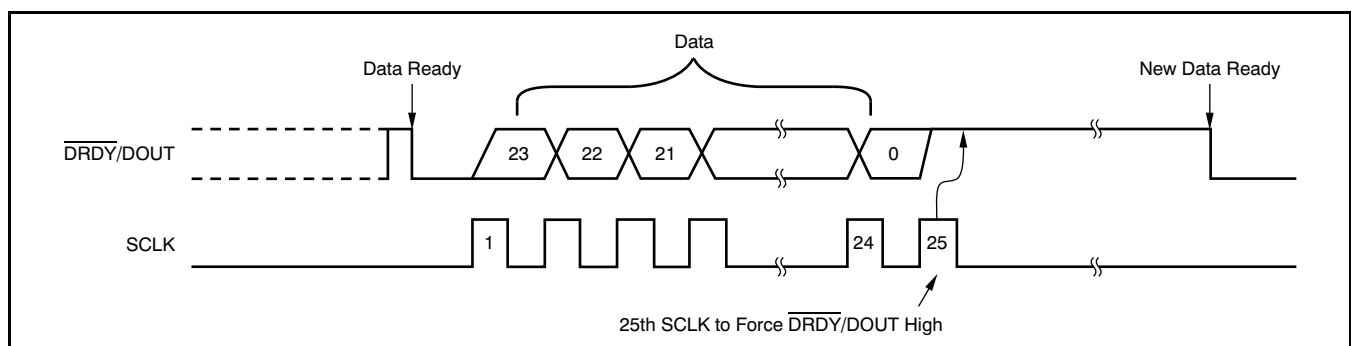

Figure 29. Data Retrieval with $\overline{\text{DRDY}}/\text{DOUT}$ Forced High Afterwards

SELF-CALIBRATION

Self-calibration can be initiated at any time by applying two additional SCLKs after retrieving 24 bits of data; however, the START pin must be kept high prior to data conversion and remain high until the calibration completes. Figure 30 and Table 6 illustrate the timing pattern. The 25th SCLK will send $\overline{\text{DRDY}}/\text{DOUT}$ high. The falling edge of the 26th SCLK will begin the calibration cycle. Additional SCLK pulses may be sent after the 26th SCLK; however, activity on SCLK should be minimized during calibration for best results.

When the calibration is complete, $\overline{\text{DRDY}}/\text{DOUT}$ goes low, indicating that new data is ready. There is no need to alter the analog input signal applied to the ADS1225 and ADS1226 during calibration; the input pins are disconnected within the A/D converter and the appropriate signals are applied internally and automatically. The first conversion after a calibration is fully settled and valid for use. The time required for a calibration depends on two independent signals: the falling edge of SCLK and an internal clock derived from CLK. Variations in the internal calibration values change the time required for calibration (t_{CAL}) within the range given by the min/max specs.

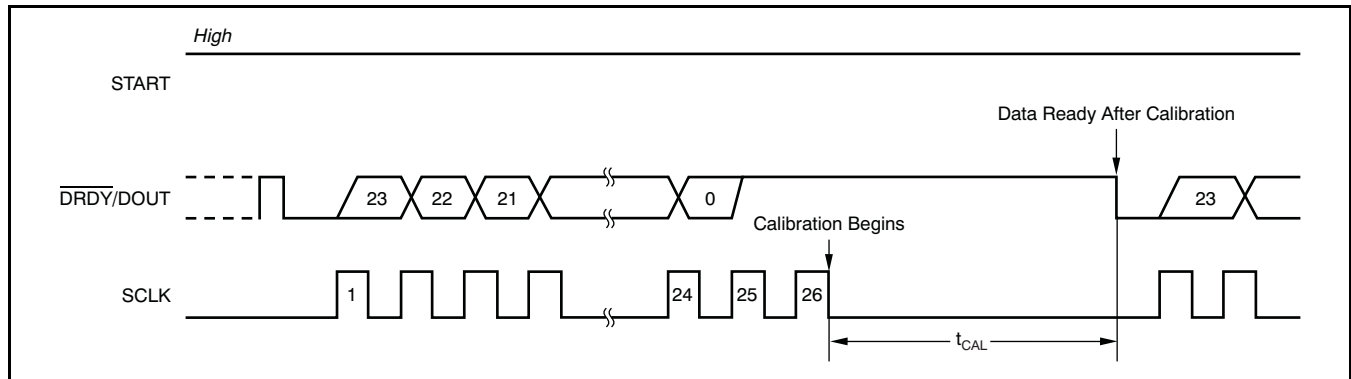

Figure 30. Self-Calibration Timing

Table 6. Self-Calibration Time for Figure 30

SYMBOL	DESCRIPTION	MIN	MAX	UNITS
t_{CAL}	First data ready after calibration	187	313	ms

APPLICATION INFORMATION

EXPOSED THERMAL PAD

The exposed thermal pads of the ADS1225 and ADS1226 are internally connected to GND. To protect the package from board stress, solder the exposed thermal pad to the printed circuit board (PCB) and leave it floating electrically. For further information, see Application Report [SLAU271, QFN/SON PCB Attachment](#), available for download from [www.ti.com](#).

GENERAL RECOMMENDATIONS

The ADS1225 and ADS1226 are high-resolution A/D converters. Achieving optimal device performance requires careful attention to the support circuitry and PCB design. [Figure 31](#) shows the basic connections for the ADS1225 and ADS1226. As with any precision circuit, be sure to use good supply bypassing capacitor techniques. A smaller value ceramic capacitor in parallel with a larger value tantalum capacitor works well. Place the capacitors, in particular the ceramic ones, close to the supply pins. Use a ground plane and tie the ADS1225 and

ADS1226 GND pin and bypass capacitors directly to it. Avoid ringing on the digital inputs. Small resistors ($\approx 100\Omega$) in series with the digital pins can help by controlling the trace impedance. Place these resistors at the source end.

Pay special attention to the reference and analog inputs. These inputs are critical to performance. Bypass the voltage reference using similar techniques to the supply voltages. The quality of the reference directly affects the overall accuracy of the device. Make sure to use a low noise and low drift reference such as the [REF1004](#). Often, only a simple RC filter is needed on the inputs. The circuit limits the higher frequency noise. Avoid low-grade dielectrics for the capacitors and place them as close as possible to the input pins. Keep the traces to the input pins short, and carefully watch how they are routed on the PCB.

After the power supplies and reference voltage have stabilized, issue a self-calibration command to minimize offset and gain errors.

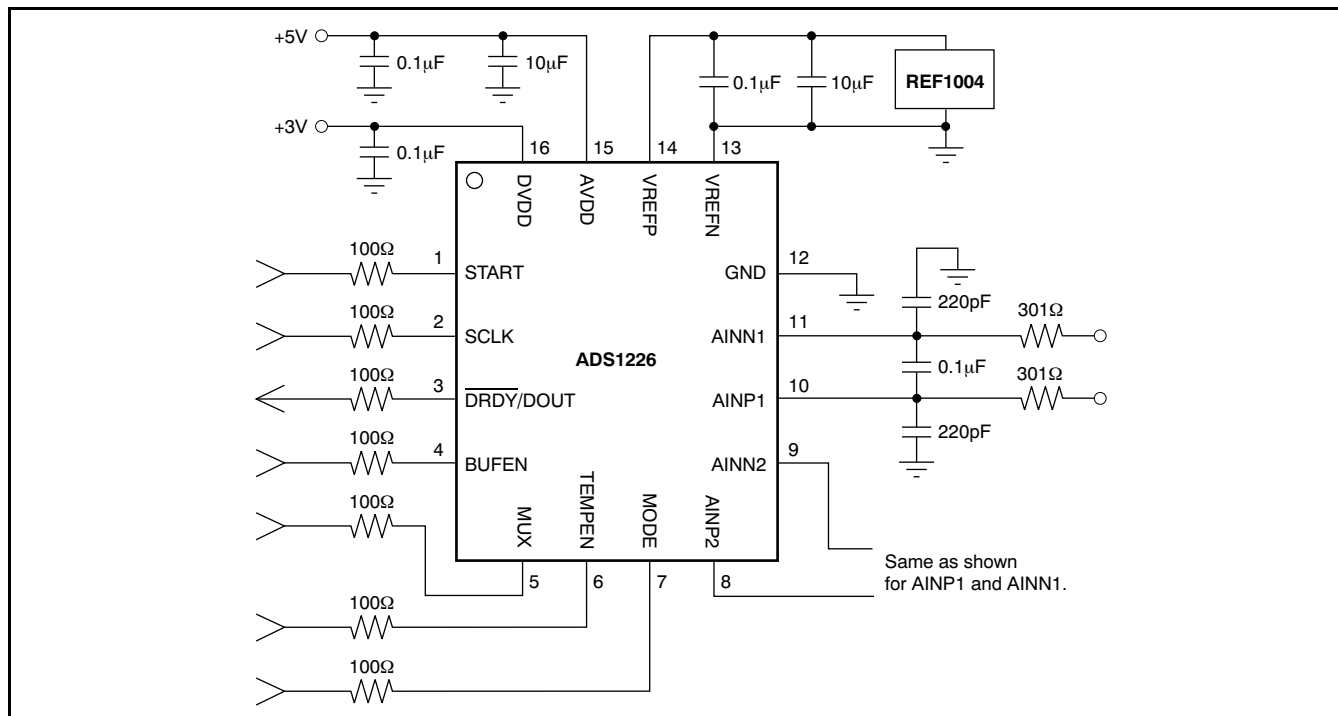

Figure 31. Basic Connections

LARGE INPUT SIGNALS

Many industrial applications require measurement of signals that go beyond 5V. The ADS1225 can be used to measure large input signals with the help of an INA159. The precision, level translation differential amplifier converts a $\pm 10V$ input to a 5V input scale. This design allows systems to be run from a single 5V supply without the need for higher voltage supplies for signal conditioning.

Figure 33 shows a basic schematic. The negative input of the INA159 is grounded while the positive input is allowed to swing from $-10V$ to $+10V$. Similarly, the negative input of the ADS1225 is grounded while the positive input swings from $0.5V$ to $+4.5V$ given the useful V_{OUT} swing of the INA159. The larger signal is easily measured without the need for extra $\pm 10V$ supplies. See the [INA159](#) data sheet for additional details.

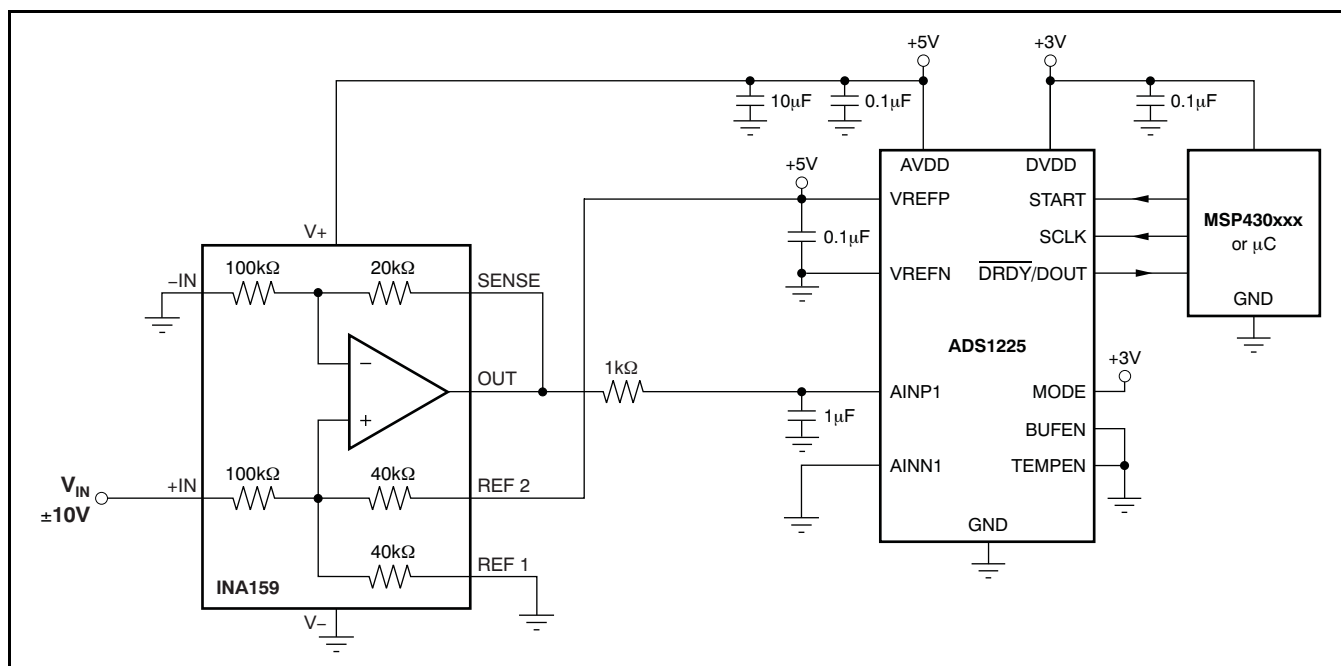

Figure 33. With the Help of an INA159, the ADS1225 Measures $\pm 10V$ Signals

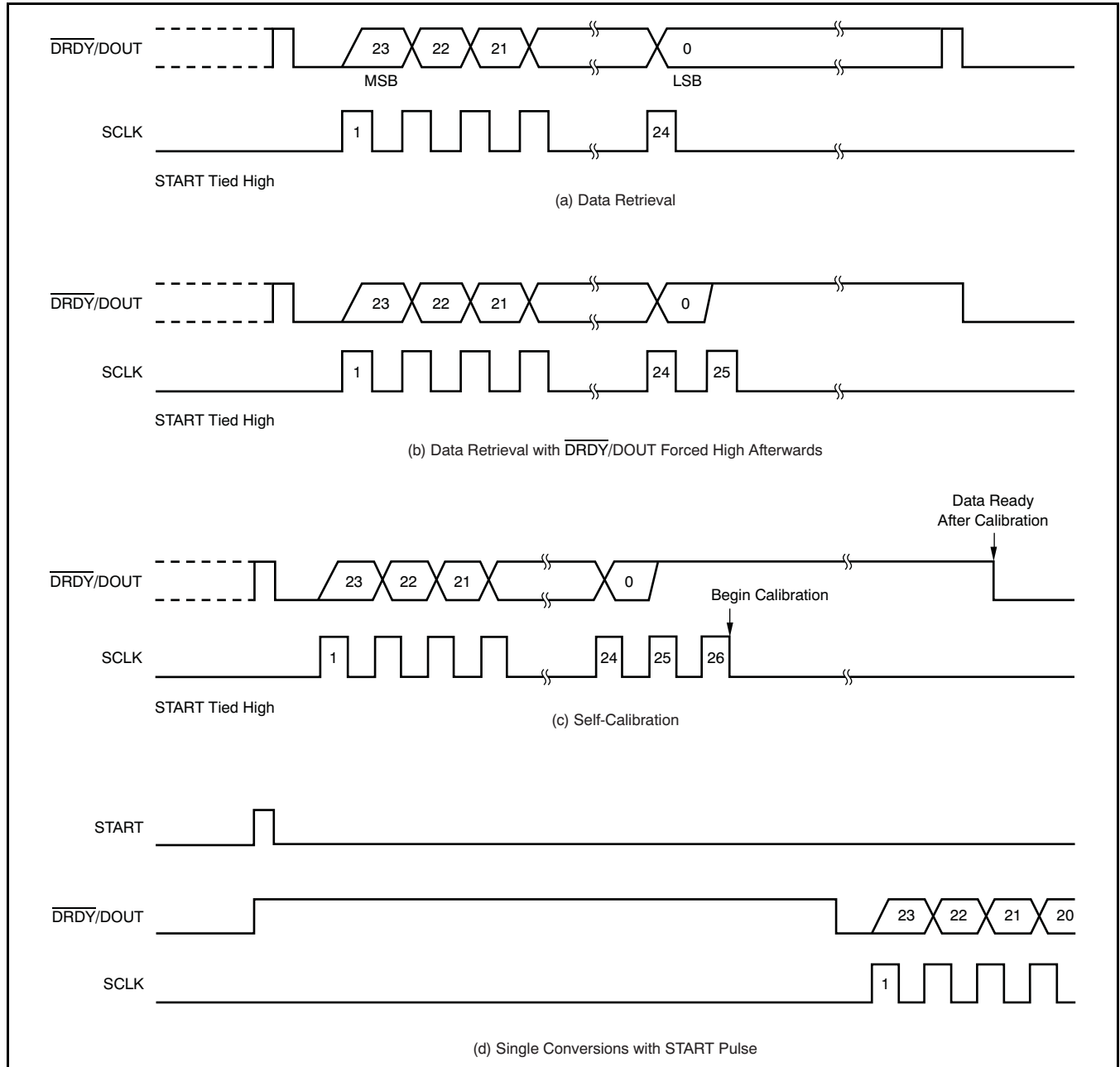

Figure 34. Summary of Serial Interface Waveforms

Table 7. Digital Pin Operations

DIGITAL PIN	PIN NO.	INPUT	
		0	1
START	1	Shutdown Mode	Start Conversion
BUFEN	4	Buffer Off	Buffer On
MUX (ADS1226 only)	5	AINP1 – AINN1 Input	AINP2 – AINN2 Input
TEMPEN	6	Temperature Sensor Off	Temperature Sensor On
MODE	7	High-Resolution Mode	High-Speed Mode

Revision History

Changes from Revision B (August 2007) to Revision C	Page
<ul style="list-style-type: none"> • Added last sentence to first paragraph of <i>Analog Input Measurement with the Input Buffer</i> section describing the START mode 11 • Added last sentence to second paragraph of <i>Start</i> section describing the START mode 14 	
Changes from Revision A (April 2007) to Revision B	Page
<ul style="list-style-type: none"> • Changed effective impedance from 250kΩ to 1.5MΩ in last sentence of <i>Voltage Reference Inputs</i> section 12 • Changed Figure 25 12 • Added text to end of <i>START</i> section regarding keeping the START pin high during calibration 14 • Changed Figure 27 title 14 • Changed text in first paragraph of <i>Self-Calibration</i> section 16 • Changed Figure 30 16 	

PACKAGING INFORMATION

Orderable Device	Status (1)	Package Type	Package Drawing	Pins	Package Qty	Eco Plan (2)	Lead/Ball Finish	MSL Peak Temp (3)	Op Temp (°C)	Top-Side Markings (4)	Samples
ADS1225IRGVR	ACTIVE	VQFN	RGV	16	2500	Green (RoHS & no Sb/Br)	CU NIPDAU	Level-2-260C-1 YEAR	-40 to 105	ADS 1225	Samples
ADS1225IRGVRG4	ACTIVE	VQFN	RGV	16	2500	Green (RoHS & no Sb/Br)	CU NIPDAU	Level-2-260C-1 YEAR	-40 to 105	ADS 1225	Samples
ADS1225IRGVT	ACTIVE	VQFN	RGV	16	250	Green (RoHS & no Sb/Br)	CU NIPDAU	Level-2-260C-1 YEAR	-40 to 105	ADS 1225	Samples
ADS1225IRGVGTG4	ACTIVE	VQFN	RGV	16	250	Green (RoHS & no Sb/Br)	CU NIPDAU	Level-2-260C-1 YEAR	-40 to 105	ADS 1225	Samples
ADS1226IRGVR	ACTIVE	VQFN	RGV	16	2500	Green (RoHS & no Sb/Br)	CU NIPDAU	Level-2-260C-1 YEAR	-40 to 105	ADS 1226	Samples
ADS1226IRGVRG4	ACTIVE	VQFN	RGV	16	2500	Green (RoHS & no Sb/Br)	CU NIPDAU	Level-2-260C-1 YEAR	-40 to 105	ADS 1226	Samples
ADS1226IRGVT	ACTIVE	VQFN	RGV	16	250	Green (RoHS & no Sb/Br)	CU NIPDAU	Level-2-260C-1 YEAR	-40 to 105	ADS 1226	Samples
ADS1226IRGVGTG4	ACTIVE	VQFN	RGV	16	250	Green (RoHS & no Sb/Br)	CU NIPDAU	Level-2-260C-1 YEAR	-40 to 105	ADS 1226	Samples

(1) The marketing status values are defined as follows:

ACTIVE: Product device recommended for new designs.

LIFEBUY: TI has announced that the device will be discontinued, and a lifetime-buy period is in effect.

NRND: Not recommended for new designs. Device is in production to support existing customers, but TI does not recommend using this part in a new design.

PREVIEW: Device has been announced but is not in production. Samples may or may not be available.

OBsolete: TI has discontinued the production of the device.

(2) Eco Plan - The planned eco-friendly classification: Pb-Free (RoHS), Pb-Free (RoHS Exempt), or Green (RoHS & no Sb/Br) - please check <http://www.ti.com/productcontent> for the latest availability information and additional product content details.

TBD: The Pb-Free/Green conversion plan has not been defined.

Pb-Free (RoHS): TI's terms "Lead-Free" or "Pb-Free" mean semiconductor products that are compatible with the current RoHS requirements for all 6 substances, including the requirement that lead not exceed 0.1% by weight in homogeneous materials. Where designed to be soldered at high temperatures, TI Pb-Free products are suitable for use in specified lead-free processes.

Pb-Free (RoHS Exempt): This component has a RoHS exemption for either 1) lead-based flip-chip solder bumps used between the die and package, or 2) lead-based die adhesive used between the die and leadframe. The component is otherwise considered Pb-Free (RoHS compatible) as defined above.

Green (RoHS & no Sb/Br): TI defines "Green" to mean Pb-Free (RoHS compatible), and free of Bromine (Br) and Antimony (Sb) based flame retardants (Br or Sb do not exceed 0.1% by weight in homogeneous material)

(3) MSL, Peak Temp. -- The Moisture Sensitivity Level rating according to the JEDEC industry standard classifications, and peak solder temperature.

⁽⁴⁾ Multiple Top-Side Markings will be inside parentheses. Only one Top-Side Marking contained in parentheses and separated by a "~" will appear on a device. If a line is indented then it is a continuation of the previous line and the two combined represent the entire Top-Side Marking for that device.

Important Information and Disclaimer: The information provided on this page represents TI's knowledge and belief as of the date that it is provided. TI bases its knowledge and belief on information provided by third parties, and makes no representation or warranty as to the accuracy of such information. Efforts are underway to better integrate information from third parties. TI has taken and continues to take reasonable steps to provide representative and accurate information but may not have conducted destructive testing or chemical analysis on incoming materials and chemicals. TI and TI suppliers consider certain information to be proprietary, and thus CAS numbers and other limited information may not be available for release.

In no event shall TI's liability arising out of such information exceed the total purchase price of the TI part(s) at issue in this document sold by TI to Customer on an annual basis.

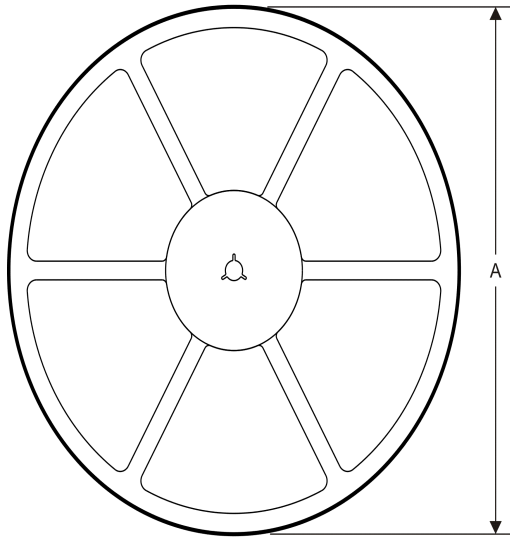
TAPE AND REEL INFORMATION
REEL DIMENSIONS

TAPE DIMENSIONS

A0	Dimension designed to accommodate the component width
B0	Dimension designed to accommodate the component length
K0	Dimension designed to accommodate the component thickness
W	Overall width of the carrier tape
P1	Pitch between successive cavity centers

TAPE AND REEL INFORMATION

*All dimensions are nominal

Device	Package Type	Package Drawing	Pins	SPQ	Reel Diameter (mm)	Reel Width W1 (mm)	A0 (mm)	B0 (mm)	K0 (mm)	P1 (mm)	W (mm)	Pin1 Quadrant
ADS1225IRGVR	VQFN	RGV	16	2500	330.0	12.4	4.25	4.25	1.15	8.0	12.0	Q2
ADS1225IRGVT	VQFN	RGV	16	250	180.0	12.4	4.25	4.25	1.15	8.0	12.0	Q2
ADS1226IRGVR	VQFN	RGV	16	2500	330.0	12.4	4.25	4.25	1.15	8.0	12.0	Q2
ADS1226IRGVT	VQFN	RGV	16	250	180.0	12.4	4.25	4.25	1.15	8.0	12.0	Q2

TAPE AND REEL BOX DIMENSIONS

*All dimensions are nominal

Device	Package Type	Package Drawing	Pins	SPQ	Length (mm)	Width (mm)	Height (mm)
ADS1225IRGVR	VQFN	RGV	16	2500	367.0	367.0	35.0
ADS1225IRGVT	VQFN	RGV	16	250	210.0	185.0	35.0
ADS1226IRGVR	VQFN	RGV	16	2500	367.0	367.0	35.0
ADS1226IRGVT	VQFN	RGV	16	250	210.0	185.0	35.0

RGV (S-PVQFN-N16)

PLASTIC QUAD FLATPACK NO-LEAD

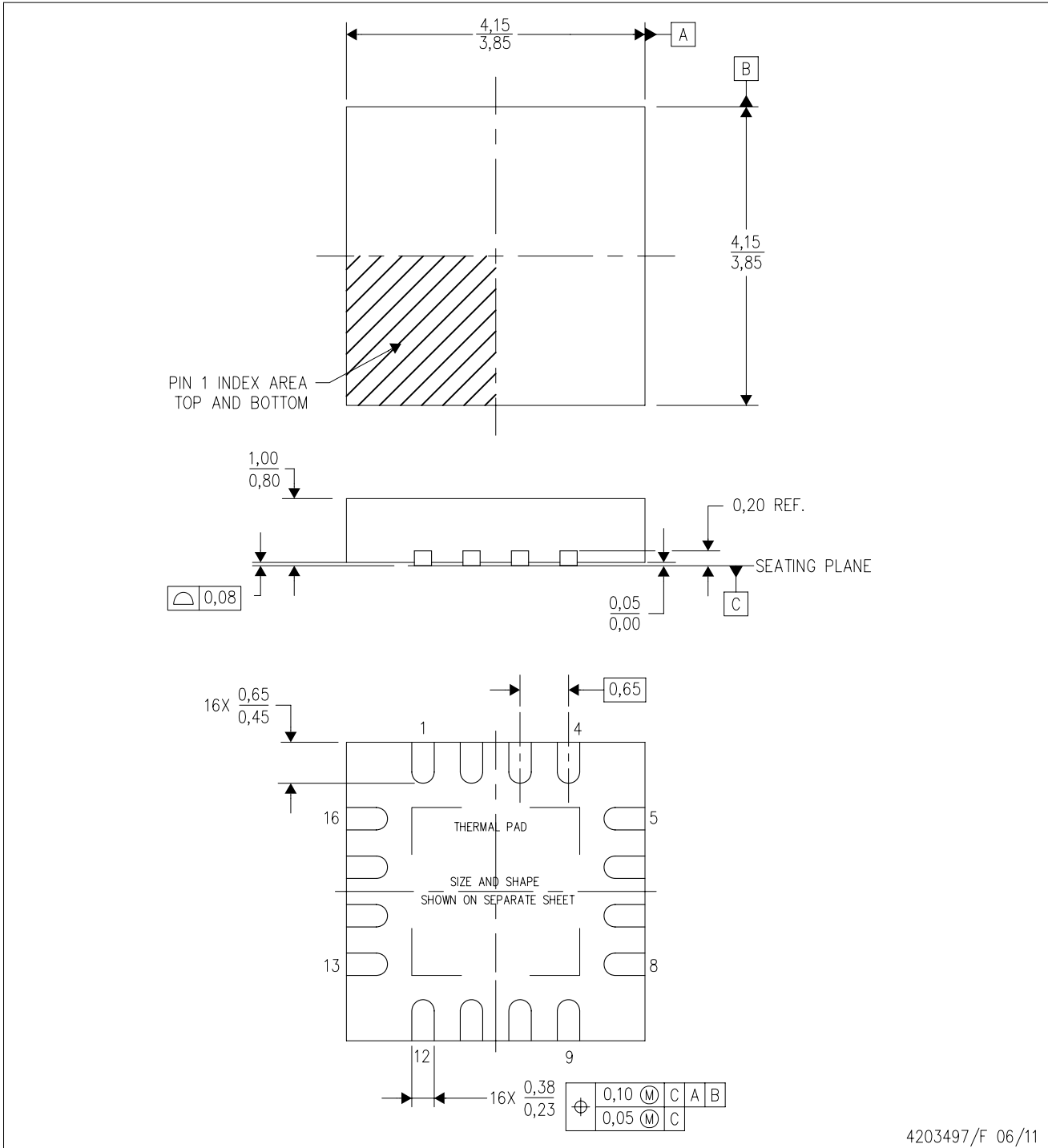

4203497/F 06/11

- NOTES:
- All linear dimensions are in millimeters. Dimensioning and tolerancing per ASME Y14.5M-1994.
 - This drawing is subject to change without notice.
 - Quad Flatpack, No-leads (QFN) package configuration.
 - The package thermal pad must be soldered to the board for thermal and mechanical performance.
 - See the additional figure in the Product Data Sheet for details regarding the exposed thermal pad features and dimensions.
 - Falls within JEDEC MO-220.

THERMAL PAD MECHANICAL DATA

RGV (S-PVQFN-N16)

PLASTIC QUAD FLATPACK NO-LEAD

THERMAL INFORMATION

This package incorporates an exposed thermal pad that is designed to be attached directly to an external heatsink. The thermal pad must be soldered directly to the printed circuit board (PCB). After soldering, the PCB can be used as a heatsink. In addition, through the use of thermal vias, the thermal pad can be attached directly to the appropriate copper plane shown in the electrical schematic for the device, or alternatively, can be attached to a special heatsink structure designed into the PCB. This design optimizes the heat transfer from the integrated circuit (IC).

For information on the Quad Flatpack No-Lead (QFN) package and its advantages, refer to Application Report, QFN/SON PCB Attachment, Texas Instruments Literature No. SLUA271. This document is available at www.ti.com.

The exposed thermal pad dimensions for this package are shown in the following illustration.

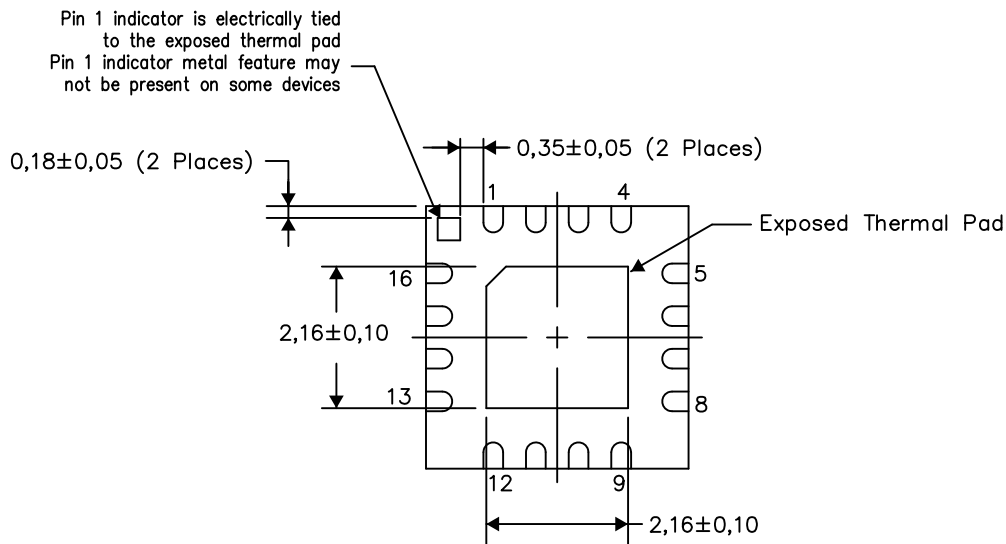

Bottom View

Exposed Thermal Pad Dimensions

4206351-2/L 05/13

NOTE: All linear dimensions are in millimeters

IMPORTANT NOTICE

Texas Instruments Incorporated and its subsidiaries (TI) reserve the right to make corrections, enhancements, improvements and other changes to its semiconductor products and services per JESD46, latest issue, and to discontinue any product or service per JESD48, latest issue. Buyers should obtain the latest relevant information before placing orders and should verify that such information is current and complete. All semiconductor products (also referred to herein as "components") are sold subject to TI's terms and conditions of sale supplied at the time of order acknowledgment.

TI warrants performance of its components to the specifications applicable at the time of sale, in accordance with the warranty in TI's terms and conditions of sale of semiconductor products. Testing and other quality control techniques are used to the extent TI deems necessary to support this warranty. Except where mandated by applicable law, testing of all parameters of each component is not necessarily performed.

TI assumes no liability for applications assistance or the design of Buyers' products. Buyers are responsible for their products and applications using TI components. To minimize the risks associated with Buyers' products and applications, Buyers should provide adequate design and operating safeguards.

TI does not warrant or represent that any license, either express or implied, is granted under any patent right, copyright, mask work right, or other intellectual property right relating to any combination, machine, or process in which TI components or services are used. Information published by TI regarding third-party products or services does not constitute a license to use such products or services or a warranty or endorsement thereof. Use of such information may require a license from a third party under the patents or other intellectual property of the third party, or a license from TI under the patents or other intellectual property of TI.

Reproduction of significant portions of TI information in TI data books or data sheets is permissible only if reproduction is without alteration and is accompanied by all associated warranties, conditions, limitations, and notices. TI is not responsible or liable for such altered documentation. Information of third parties may be subject to additional restrictions.

Resale of TI components or services with statements different from or beyond the parameters stated by TI for that component or service voids all express and any implied warranties for the associated TI component or service and is an unfair and deceptive business practice. TI is not responsible or liable for any such statements.

Buyer acknowledges and agrees that it is solely responsible for compliance with all legal, regulatory and safety-related requirements concerning its products, and any use of TI components in its applications, notwithstanding any applications-related information or support that may be provided by TI. Buyer represents and agrees that it has all the necessary expertise to create and implement safeguards which anticipate dangerous consequences of failures, monitor failures and their consequences, lessen the likelihood of failures that might cause harm and take appropriate remedial actions. Buyer will fully indemnify TI and its representatives against any damages arising out of the use of any TI components in safety-critical applications.

In some cases, TI components may be promoted specifically to facilitate safety-related applications. With such components, TI's goal is to help enable customers to design and create their own end-product solutions that meet applicable functional safety standards and requirements. Nonetheless, such components are subject to these terms.

No TI components are authorized for use in FDA Class III (or similar life-critical medical equipment) unless authorized officers of the parties have executed a special agreement specifically governing such use.

Only those TI components which TI has specifically designated as military grade or "enhanced plastic" are designed and intended for use in military/aerospace applications or environments. Buyer acknowledges and agrees that any military or aerospace use of TI components which have **not** been so designated is solely at the Buyer's risk, and that Buyer is solely responsible for compliance with all legal and regulatory requirements in connection with such use.

TI has specifically designated certain components as meeting ISO/TS16949 requirements, mainly for automotive use. In any case of use of non-designated products, TI will not be responsible for any failure to meet ISO/TS16949.

Products

Audio	www.ti.com/audio
Amplifiers	amplifier.ti.com
Data Converters	dataconverter.ti.com
DLP® Products	www.dlp.com
DSP	dsp.ti.com
Clocks and Timers	www.ti.com/clocks
Interface	interface.ti.com
Logic	logic.ti.com
Power Mgmt	power.ti.com
Microcontrollers	microcontroller.ti.com
RFID	www.ti-rfid.com
OMAP Applications Processors	www.ti.com/omap
Wireless Connectivity	www.ti.com/wirelessconnectivity

Applications

Automotive and Transportation	www.ti.com/automotive
Communications and Telecom	www.ti.com/communications
Computers and Peripherals	www.ti.com/computers
Consumer Electronics	www.ti.com/consumer-apps
Energy and Lighting	www.ti.com/energy
Industrial	www.ti.com/industrial
Medical	www.ti.com/medical
Security	www.ti.com/security
Space, Avionics and Defense	www.ti.com/space-avionics-defense
Video and Imaging	www.ti.com/video

TI E2E Community

e2e.ti.com