

REVISIONS

P	LTR	DESCRIPTION	DATE	DWN	APVD
	A	INITIAL	24SEP2016	YC	CW

NOTES:

- TECHNICAL CHARACTERISTICS:
 INSULATION MATERIAL: PC
 CONTACT MATERIAL: BRASS, GOLD PLATED
 RATED VOLTAGE: 500V
 RATED CURRENT: 16A
 INSULATION RESISTANCE: $\geq 400M\Omega$
 RATED IMPULSE VOLTAGE: 6KV
 POLLUTION DEGREE: 3
 FLAMMABILITY: UL94V-0
 MATING CYCLES: 500 CYCLES
 WIRE RANGE: $0.5mm^2 \sim 2.5mm^2$ (AWG20-AWG14)
 CONTACT TYPE: SCREW CLAMP (M3)

注释:

- 技术参数:
 绝缘材料: PC
 端子材料: 黄铜, 镀金
 额定电压: 500V
 额定电流: 16A
 绝缘电阻: $\geq 400M\Omega$
 脉冲电压: 6KV
 污染等级: 3
 阻燃等级: UL94V-0
 插拔次数: 500 次
 接线范围: $0.5mm^2 \sim 2.5mm^2$ (AWG20-AWG14)
 接线类型: 螺丝压接 (M3)

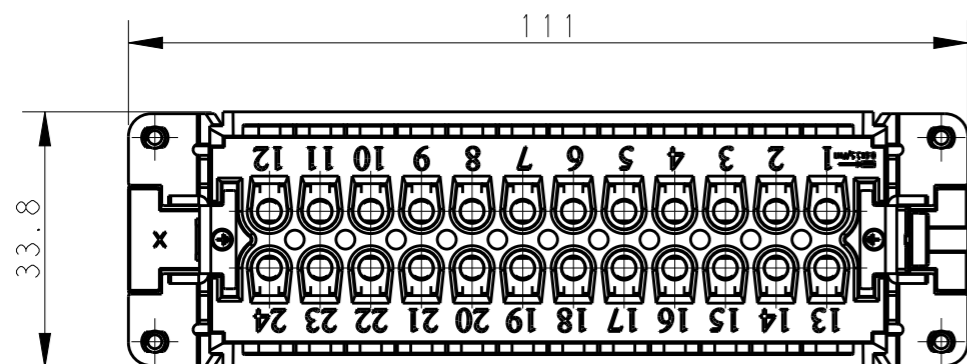

24X M3 SCREW, RECOMMENDED
 TIGHTENING TORQUE 0.5Nm
 24X M3螺丝, 推荐锁紧力矩0.5Nm

M4 SCREW, RECOMMENDED
 TIGHTENING TORQUE 1.2Nm
 M4螺丝, 推荐锁紧力矩1.2Nm

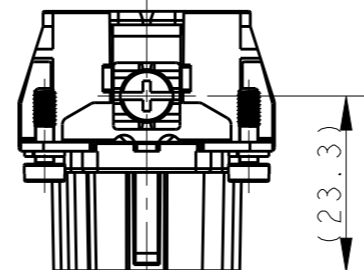
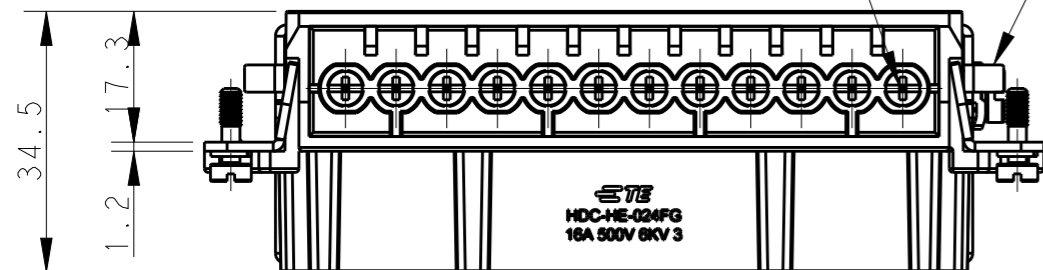

4X M3 SCREW, RECOMMENDED
 TIGHTENING TORQUE 0.5Nm
 4X M3螺丝, 推荐锁紧力矩0.5Nm

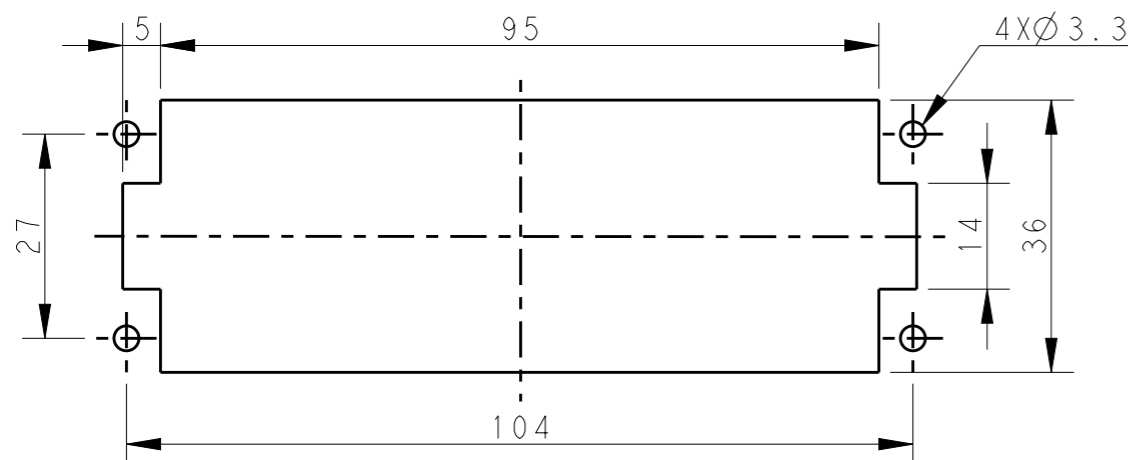
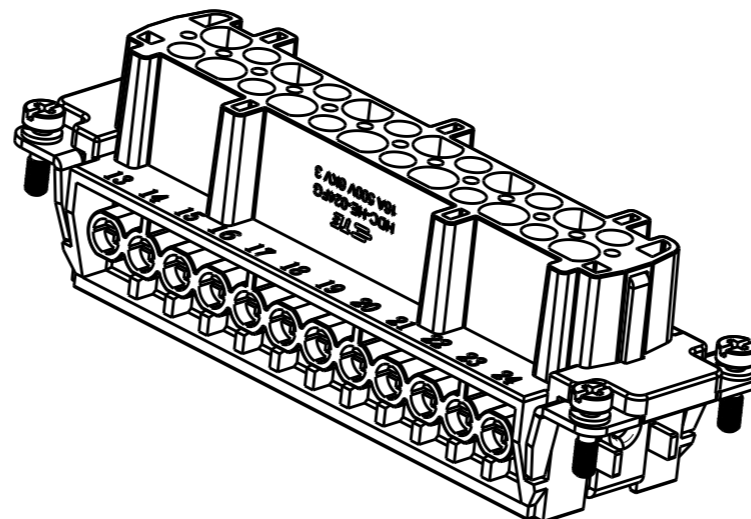
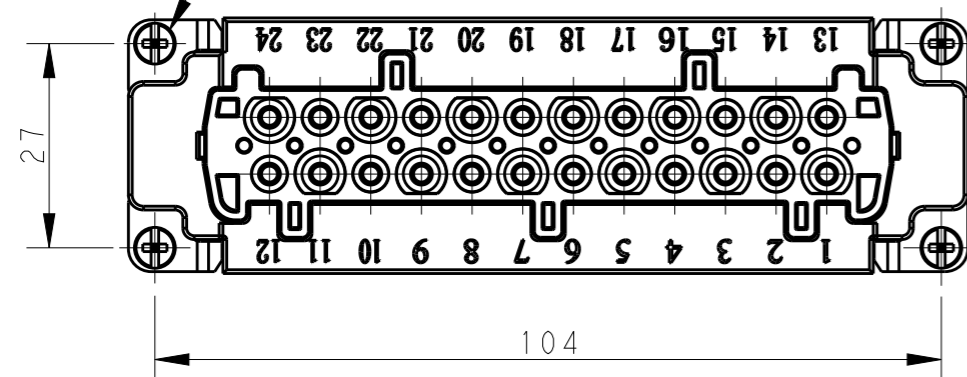

PANEL CUT FOR INSERTS FOR USE
 WITHOUT HOODS/ HOUSINGS
 不使用防护外壳时芯件的安装开孔图

T2040242211-000	HE-024-FG	HE-024 FEMALE INSERT, GOLD PLATED HE-024 母插, 镀金
PART NUMBER 料号	PART DESCRIPTION 描述	

THIS DRAWING IS A CONTROLLED DOCUMENT.		DWN 24SEP2016 YORK CHEN	TE Connectivity	
DIMENSIONS: mm		CHK 24SEP2016 KYLE ZENG		
TOLERANCES UNLESS OTHERWISE SPECIFIED:		APVD 24SEP2016 CHRIS WANG	NAME HE-024-FG	
0 PLC ±-		PRODUCT SPEC 108-137044	SIZE A3	
1 PLC ±-		APPLICATION SPEC 114-137044	CAGE CODE 00779	DRAWING NO T2040242211000
2 PLC ±-		MATERIAL -	WEIGHT -	RESTRICTED TO -
3 PLC ±-		FINISH -	SCALE 1:1	
4 PLC ±-		CUSTOMER DRAWING		
ANGLES ±-		SHEET 1 OF 1		REV A