

**PLEASE CHECK WWW.MOLEX.COM FOR LATEST PART INFORMATION**

**Part Number:** [0473370001](#)  
**Status:** **Active**  
**Description:** Camera Socket for Mobile Phone, Top Mount, SMT, Side Contact Type, 8.5x8.5

**Documents:**

[3D Model](#) [Product Specification PS-47337-001 \(PDF\)](#)  
[Drawing \(PDF\)](#) [RoHS Certificate of Compliance \(PDF\)](#)

**General**

Product Family	Other Sockets
Series	<a href="#">47337</a>
Component Type	Socket
Product Name	Camera Socket

**Physical**

Circuits (Loaded)	24
Circuits (maximum)	24
Color - Resin	Black
Durability (mating cycles max)	30
Entry Angle	Vertical
Keying to Mating Part	Yes
Material - Metal	Phosphor Bronze
Material - Plating Mating	Gold
Material - Plating Termination	Gold
Material - Resin	High Temperature Thermoplastic
PCB Locator	No
PCB Retention	N/A
PCB Thickness Recommended (in)	0.020 In
PCB Thickness Recommended (mm)	0.50 mm
Packaging Type	Embossed Tape on Reel
Pitch - Mating Interface (in)	0.035 In
Pitch - Mating Interface (mm)	0.90 mm
Pitch - Term. Interface (in)	0.035 In
Pitch - Term. Interface (mm)	0.90 mm
Plating min: Mating (µin)	12
Plating min: Mating (µm)	0.3
Plating min: Termination (µin)	3
Plating min: Termination (µm)	0.075
Temperature Range - Operating	-55°C to +85°C
Termination Interface: Style	Surface Mount

**Electrical**

Current - Maximum per Contact	0.5A
Voltage - Maximum	50V DC

**Solder Process Data**

Duration at Max. Process Temperature (seconds)	10
Lead-free Process Capability	Reflow Capable (SMT only)
Max. Cycles at Max. Process Temperature	1
Process Temperature max. C	250

**Material Info**

**Reference - Drawing Numbers**

Product Specification	PS-47337-001
Sales Drawing	SD-47337-001

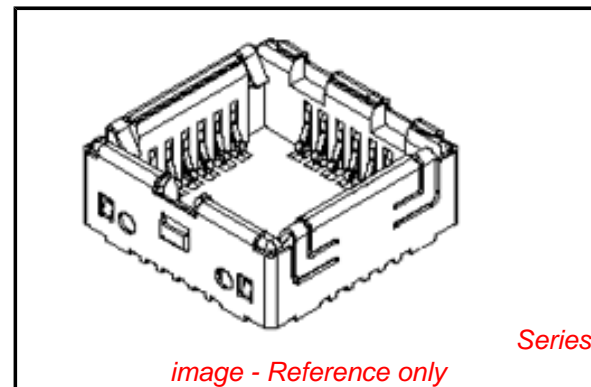

**EU RoHS**

**ELV and RoHS  
Compliant**  
**REACH SVHC**  
 Not Reviewed  
**Halogen-Free  
Status**  
**Not Reviewed**

**China RoHS**



**Need more information on product  
environmental compliance?**

Email [productcompliance@molex.com](mailto:productcompliance@molex.com)  
 For a multiple part number RoHS Certificate of  
 Compliance, [click here](#)

Please visit the [Contact Us](#) section for any  
 non-product compliance questions.

**Search Parts in this Series**

[47337Series](#)

**Mates With**

[Camera Module](#)

**Use With**

[47337-0005 Cap](#)

This document was generated on 03/31/2010

**PLEASE CHECK [WWW.MOLEX.COM](http://WWW.MOLEX.COM) FOR LATEST PART INFORMATION**

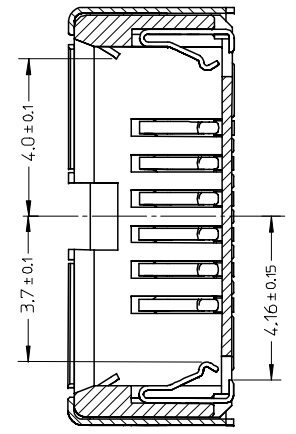
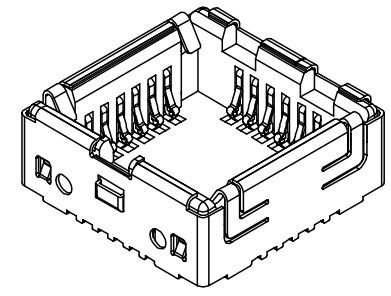
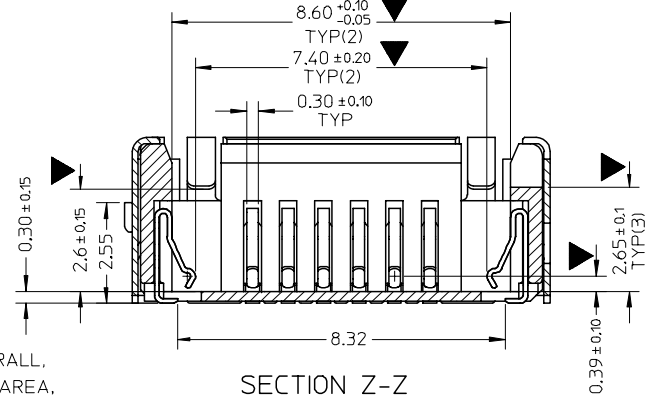
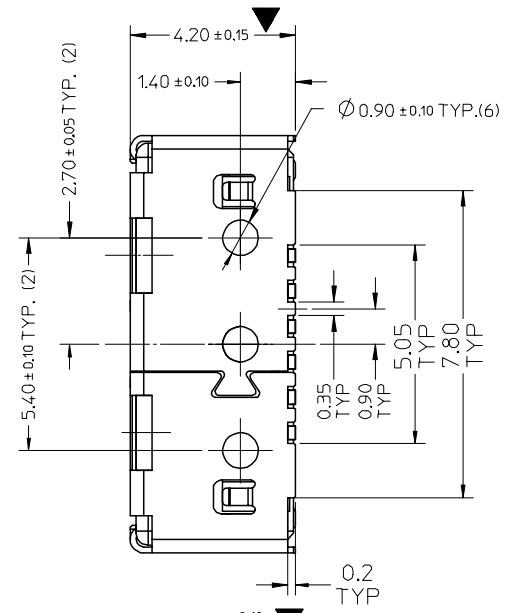
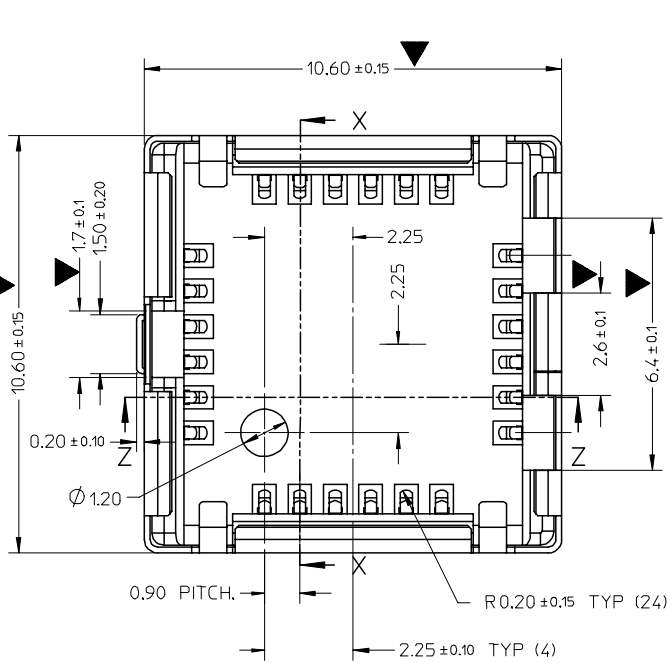

SECTION X-X

- NOTES:
- MATERIALS  
HOUSING: POLYAMIDE, BLACK, UL94 V-0  
TERMINAL: COPPER ALLOY.  
SHELL: COPPER ALLOY.  
TOP SHIELD: STAINLESS STEEL
  - FINISH  
TERMINAL: 2-4 MICROMETER NICKEL UNDERPLATING OVERALL,  
GOLD PLATING 0.3 MICROMETER ON CONTACT AREA,  
GOLD FLASH PLATING ON SOLDER AREA.  
SHELL: 2-4 MICROMETER NICKEL UNDERPLATING OVERALL,  
GOLD FLASH PLATING ON SOLDER AREA.
  - PRODUCT SPECIFICATION: PS-47337-001
  - PAKAGING: TAPE&REEL
  - COPLANALITY TO BE 0.10MM MAX.
  - APPLICABLE TOP COVER 473370005.
  - APPLICABLE CAMERA MODULE SEE SHEET 3.
  - THE DRAWING EDITION 9 WILL MEET TOM LU'S DRAWING EDITON S6

SECTION Z-Z

RELEASE EC NO: DRWN: IHE CHKD: XIXU APPR: JNCHEN 2006/06/16 2006/06/23 2006/06/26	DESCRIPTION REV A	QUALITY SYMBOLS ▽=12 ◁=0	GENERAL TOLERANCES (UNLESS SPECIFIED)		DIMENSION STYLE MM ONLY		SCALE 8:1	DESIGN UNITS METRIC	THIRD ANGLE PROJECTION		
			mm	INCH	DRAWN BY	DATE	TITLE 8.5*8.5 CAMERA SOCKET SMT.SIDE CONTACT TYPE TOP MOUNT				
		4 PLACES	± ---	± ---	IVAN HE	2006/06/16					
		3 PLACES	± ---	± ---	CHECKED BY	DATE	MOLEX INCORPORATED				
2 PLACES	± 0.10	± ---	XIXU	2006/06/16							
1 PLACE	± 0.15	± ---	APPROVED BY	DATE	DOCUMENT NO. SD-47337-001						
ANGULAR			± 1 °	JENNY CHEN						2006/06/16	
DRAFT WHERE APPLICABLE MUST REMAIN WITHIN DIMENSIONS			MATERIAL NO.		473370001		SHEET NO.		1 OF 3		
THIS DRAWING CONTAINS INFORMATION THAT IS PROPRIETARY TO MOLEX INCORPORATED AND SHOULD NOT BE USED WITHOUT WRITTEN PERMISSION											

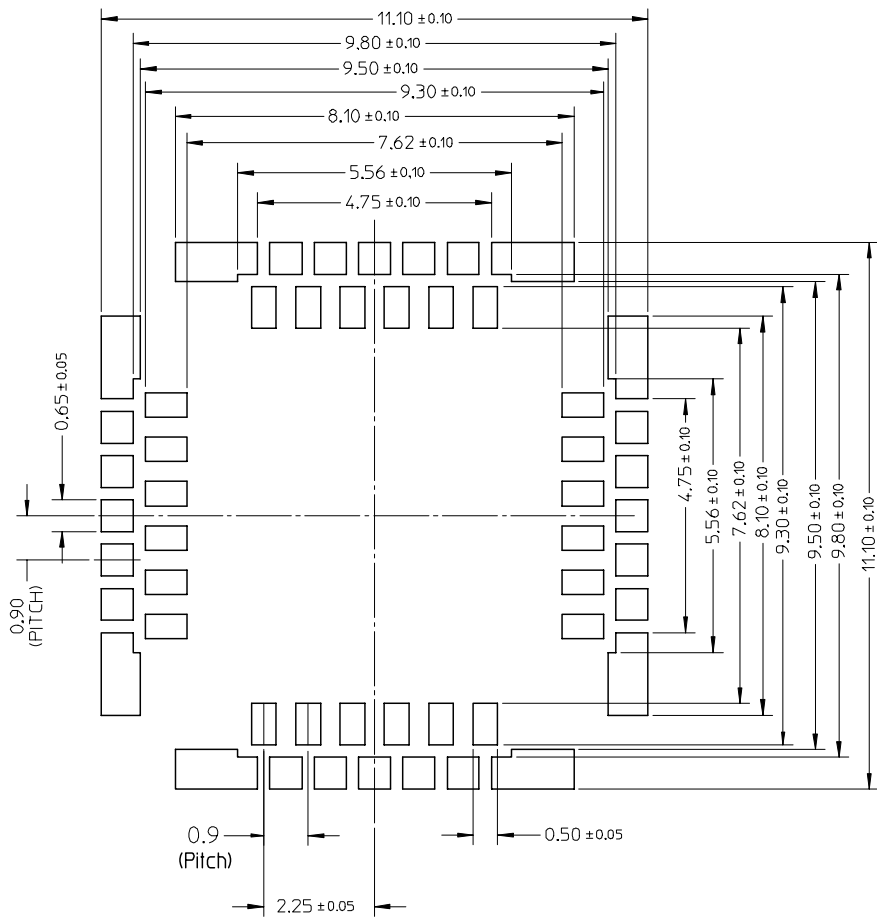

RECOMMENDED PCB LAYOUT

RELEASE	2006/06/16
EC NO:	2006/06/23
DRWN: IHE	2006/06/23
CHKD: XIXU	
APPR: JNCHEN	2006/06/26
REV	
A	

QUALITY SYMBOLS	DESCRIPTION
▽=0	
∇=0	

GENERAL TOLERANCES (UNLESS SPECIFIED)	
	MM ONLY
	INCH
4 PLACES	± ---
3 PLACES	± ---
2 PLACES	± 0.10
1 PLACE	± 0.15
ANGULAR ± 1	
DRAFT WHERE APPLICABLE MUST REMAIN WITHIN DIMENSIONS	

DIMENSION STYLE	
MM ONLY	
DRAWN BY	DATE
IVAN HE	2006/06/16
CHECKED BY	DATE
XIXU	2006/06/16
APPROVED BY	DATE
JENNY CHEN	2006/06/16
MATERIAL NO.	
47337-0001	
SIZE	
A3	

SCALE	DESIGN UNITS	THIRD ANGLE PROJECTION
10:1	METRIC	
TITLE		
8.5*8.5 CAMERA SOCKET SMT.SIDE CONTACT TYPE TOP MOUNT		
MOLEX INCORPORATED		
DOCUMENT NO.		SHEET NO.
SD-47337-001		2 OF 3
THIS DRAWING CONTAINS INFORMATION THAT IS PROPRIETARY TO MOLEX INCORPORATED AND SHOULD NOT BE USED WITHOUT WRITTEN PERMISSION		

# APPLIED CAMERA MODULE

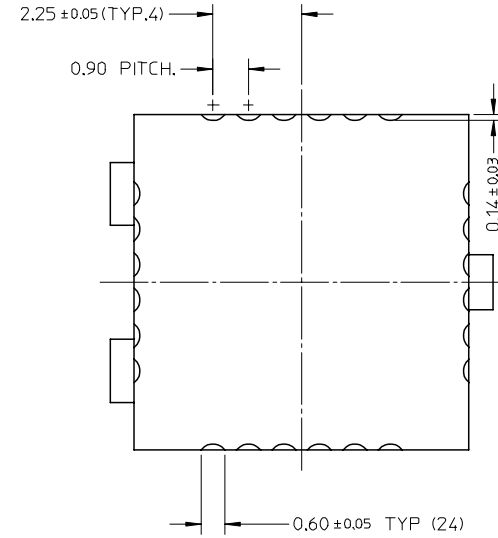
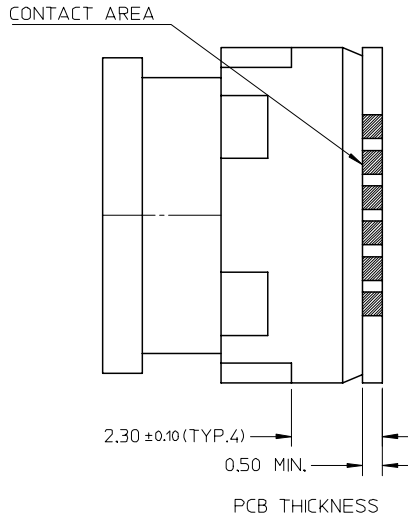
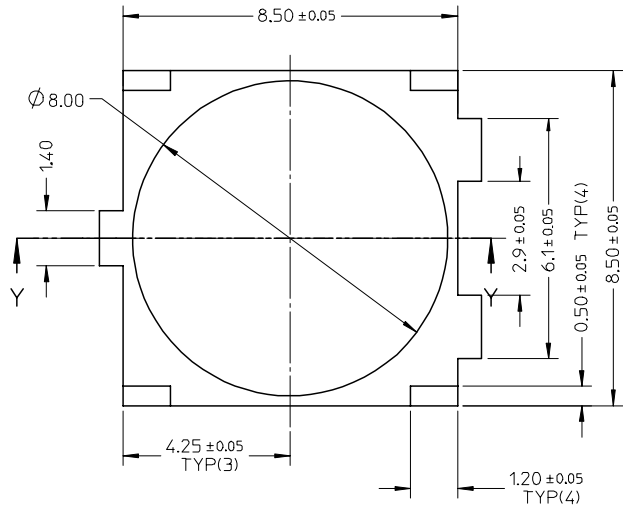

FOR PCB (PTH)

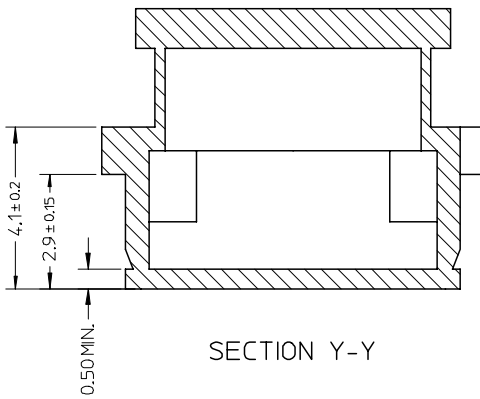

SECTION Y-Y

RELEASE EC NO: DRWN: IHE CHKD: XIXU APPR: JNCHEN	2006/06/16 2006/06/23 2006/06/26	DESCRIPTION REV	QUALITY SYMBOLS	GENERAL TOLERANCES (UNLESS SPECIFIED)	DIMENSION STYLE	SCALE	DESIGN UNITS	THIRD ANGLE PROJECTION
			$\nabla=0$ $\sphericalangle=0$	mm      INCH	MM ONLY	8:1	METRIC	
			4 PLACES ± --- ± --- 3 PLACES ± --- ± --- 2 PLACES ± 0.10 ± --- 1 PLACE ± 0.15 ± ---	DRAWN BY      DATE IVAN HE      2006/06/16 CHECKED BY      DATE XIXU      2006/06/16 APPROVED BY      DATE JENNY CHEN      2006/06/16	TITLE	MOLEX INCORPORATED		
			ANGULAR ± 1 °	MATERIAL NO. 47337-0001	DOCUMENT NO. SD-47337-001	SHEET NO. 3 OF 3		
A			DRAFT WHERE APPLICABLE MUST REMAIN WITHIN DIMENSIONS	SIZE A3	THIS DRAWING CONTAINS INFORMATION THAT IS PROPRIETARY TO MOLEX INCORPORATED AND SHOULD NOT BE USED WITHOUT WRITTEN PERMISSION			