

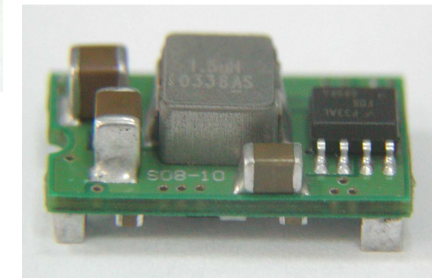

SIPSMT05-05 SERIES 5 AMP POL CONVERTERS

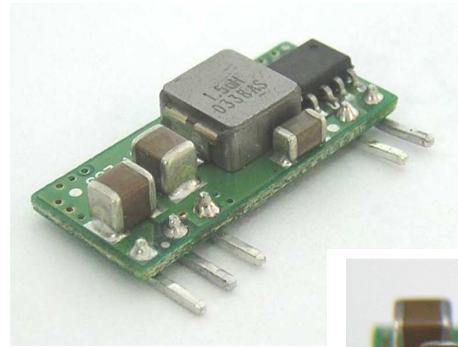

FEATURES

- * Non-isolated POL Converter
- * SIP / SMT Package
- * Output Current 5AMP
- * Input Voltage Range 3.0 – 5.5VDC
- * Output Voltage Range 0.75 – 3.63VDC
- * High Efficiency to 94%
- * Over Temperature Protection
- * Continuous Short Circuit Protection
- * Remote ON/OFF
- * UL/C-UL60950 Certified

MODEL NUMBER	INPUT VOLTAGE	OUTPUT VOLTAGE	OUTPUT CURRENT	INPUT CURRENT		Efficiency (%)
				NO LOAD	FULL LOAD	
SIP05-05S33A	3.0 – 5.5VDC	0.75VDC	5A	25mA	949mA	79
		1.2VDC	5A	30mA	1412mA	85
		1.5VDC	5A	30mA	1724mA	87
		1.8VDC	5A	35mA	2022mA	89
SMT05-05S33A		2.0VDC	5A	35mA	2222mA	90
		2.5VDC	5A	35mA	2217mA	92
	4.5 – 5.5VDC	3.3VDC	5A	35mA	3511mA	94

NOTE: Nominal Input Voltage 5.0VDC

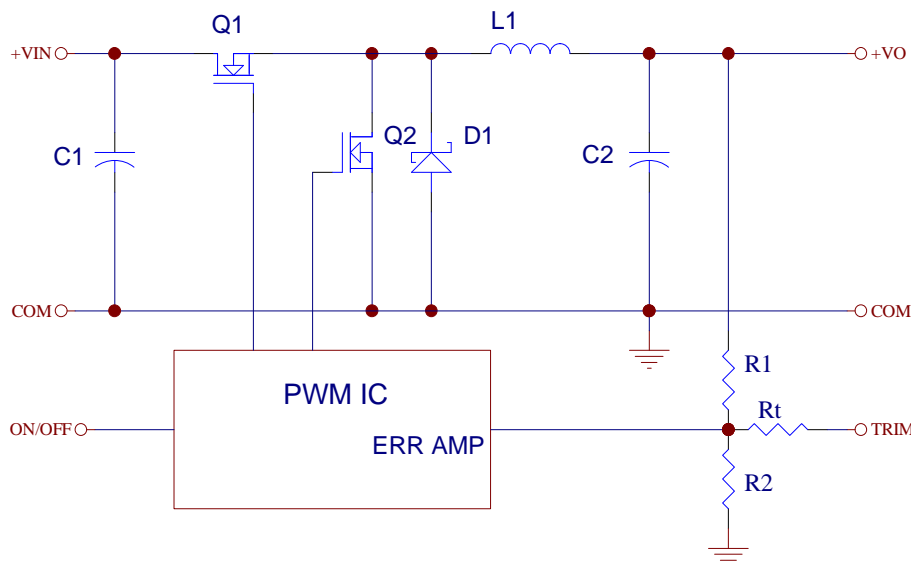

Vo,set (V)	Rtrim (KΩ)
0.75	Open
1.2	41.71
1.5	22.98
1.8	14.96
2.0	11.75
2.5	6.93
3.3	3.15
3.63	2.20

Table 1. External Resistor Values for programming output voltage

Figure 1. Simplified Schematic

SPECIFICATIONS

All Specifications Typical At Nominal Line, Full Load, and 25°C Unless Otherwise Noted

INPUT SPECIFICATIONS:

Input Voltage Range $V_o, set \leq V_{in}-0.5VDC$ 5V 3.0 – 5.5V
 Under Voltage Lock-out Power up 2.0V typ.
 Power down 1.9V typ.
 Input Filter Type Capacitive
 Positive Remote on/off Control:
 Module ON Open Circuit or = V_{in}
 Module OFF <0.4Vdc

OUTPUT SPECIFICATIONS:

Voltage Accuracy $\pm 1.5\%$ max.
 Transient Response: 50% Step Load Change <200us
 Ripple and Noise, 20MHz BW (note 3) 20mVrms max.
 50mVpk-pk max.
 Temperature Coefficient $\pm 0.03\%/^{\circ}C$ max.
 Short Circuit Protection Continuous
 Line Regulation (note 1) $\pm 0.4\%$ max.
 Load Regulation (note 2) $\pm 0.5\%$ max.
 Capacitive Load Low ESR 3000uF max.
 External Trim Adj. Range (see Table1) $V_o=0.75 - 3.63Vdc$
 Start up time 6.5ms typ.

GENERAL SPECIFICATIONS:

Efficiency See Table
 Isolation Voltage Non-isolation
 Switching Frequency 300KHz typ.
 Over Temperature Protection 120°C typ.
 Operating Ambient Temperature Range -40°C to +85°C
 Power De-rating Curve see Figure2, 3
 Storage Temperature Range -55°C to +125°C
 MTBF MIL-STD-217F, GB, 25°C, Full Load 1.5Mhrs typ.
 Dimensions: SIP Package: 0.90x0.400x0.22 inches (22.9x10.16x5.6 mm)
 SMT Package: 0.80x0.450x0.24 inches (20.3x11.43x6.09 mm)
 Structure Non-potted With Open Frame Type
 Weight 2.3g

NOTE:

1. Measured From High Line to Low Line, $V_o, set=1.8Vdc$
2. Measured From Full Load to Zero Load, $V_o, set=3.3Vdc$
3. The output noise is measured with 10uf tantalum capacitor and 1uf ceramic capacitor across output.
4. The Input Terminal Recommend to Parallel With 100uF Capacitor $ESR < 100m\Omega$ to Reduce The Input Ripple Voltage
5. Suffix "N" to the Model Number with Negative Logic Remote on/off
 Model ON Open Circuit or < 0.4VDC
 Module OFF >+2.8VDC to V_{in}

Dimensions:

SIP Packages

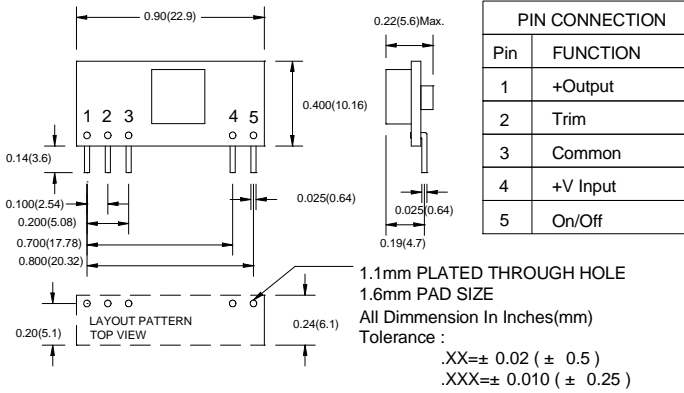

SMT Packages

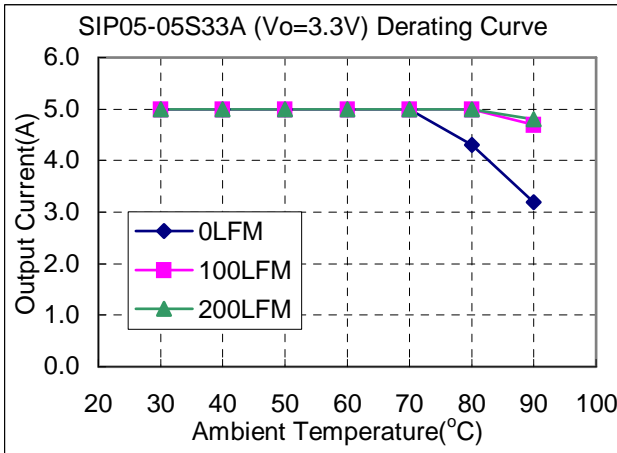
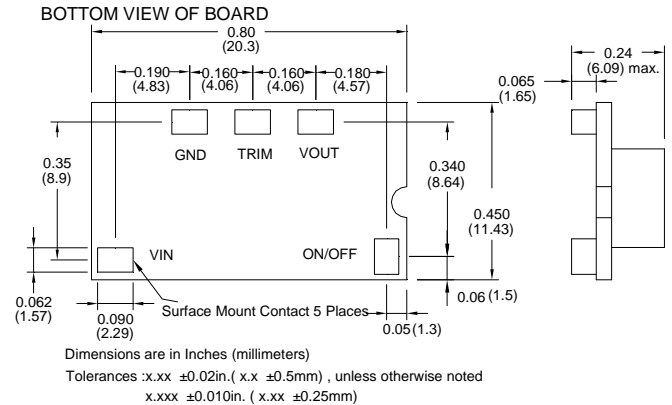

Figure2. Typical Power De-rating for 5V IN 3.3Vout

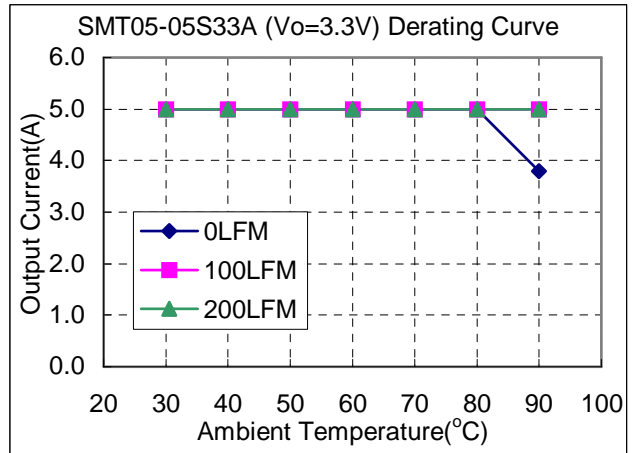

Figure3. Typical Power De-rating for 5V IN 3.3Vout