

THIS DRAWING IS UNPUBLISHED. RELEASED FOR PUBLICATION  
 © COPYRIGHT - By - ALL RIGHTS RESERVED.

LOC	DIST	REVISIONS			
P	LTR	DESCRIPTION	DATE	DWN	APVD
AD	00	A	NEW DRAWING PER ECO-14-007623	22MAY2014	NK RH

CONVERSION CHART

INCH	MM
.001	0.03
.002	0.05
.004	0.10
.005	0.13
.008	0.20
.016	0.41
.018	0.46
.025	0.64
.033	0.84
.049	1.24
.057	1.45
.140	3.56
.197	5.00
.300	7.62

MATERIAL:

PHOSPHOR BRONZE PER AUGAT SPEC.  
3310-317

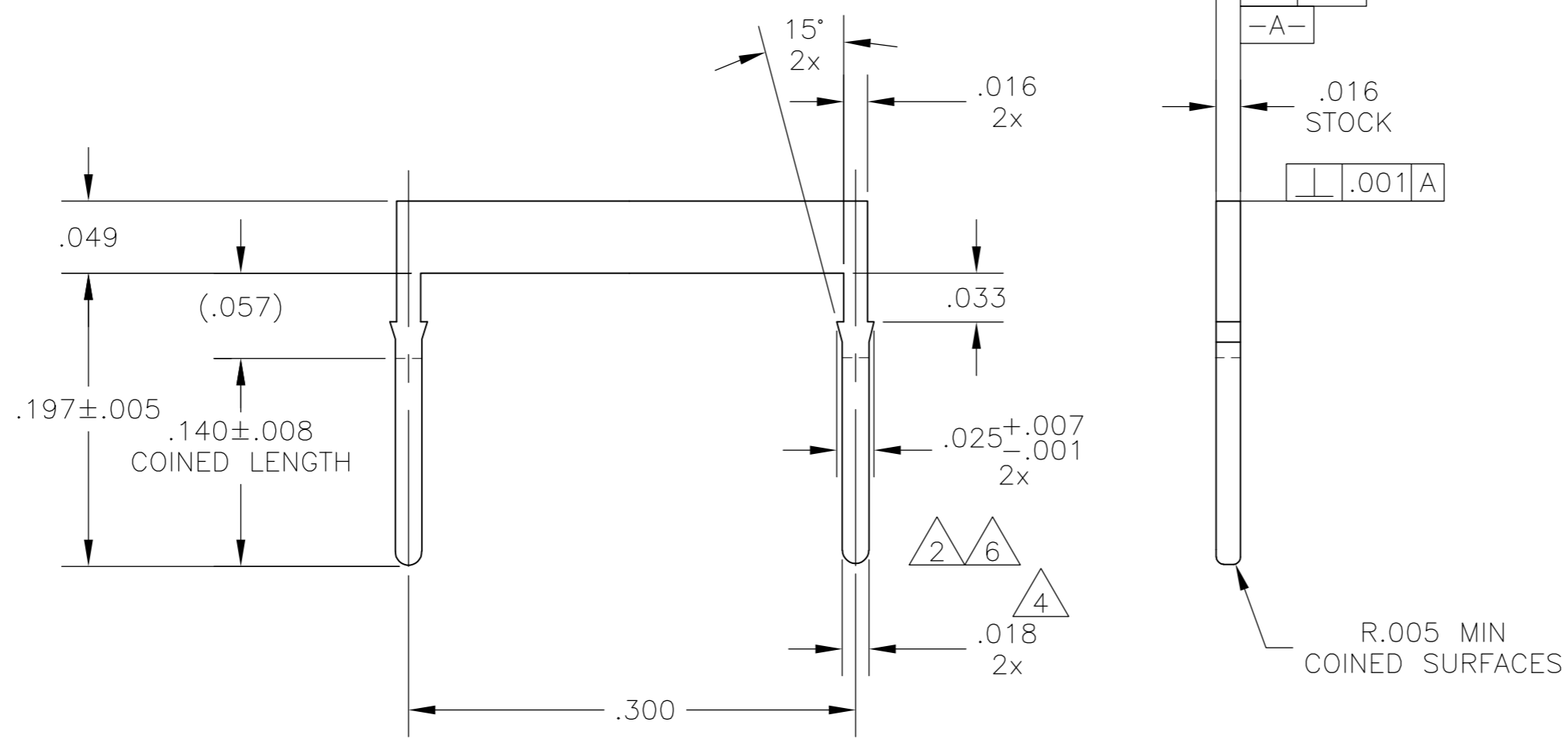
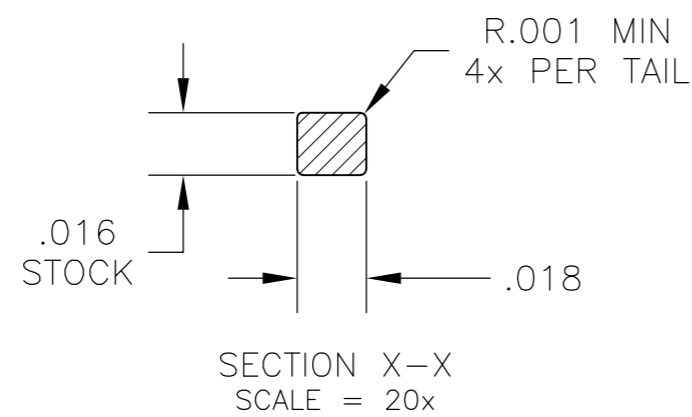

1 PACKAGE QUANTITY NOT TO EXCEED 20000. CONTAINER TO BE A FLAT BOX, APPROXIMATELY 4"x6"x1"

THIS DRAWING IS A CONTROLLED DOCUMENT.		DWN NAGALAKSHMI K 22MAY2014	<b>STE</b> TE Connectivity	
DIMENSIONS: INCHES		CHK HILL, RYAN 22MAY2014		
TOLERANCES UNLESS OTHERWISE SPECIFIED:		APVD HILL, RYAN 22MAY2014	NAME	
0 PLC ± -		PRODUCT SPEC	SHORTING PIN	
1 PLC ± -		APPLICATION SPEC	SIZE	CAGE CODE
2 PLC ± -			A2	00779
3 PLC ± .005			DRAWING NO	RESTRICTED TO
4 PLC ± -			C=2-1437507-3	-
ANGLES ± 1°			SCALE	SHEET
FINISH		WEIGHT	10:1	1 OF 1
-		CUSTOMER DRAWING	REV	A