

Tilt Sensor Switch

Item No.	VBS040200T	Description	Photoelectric	Version	9
Page	1 of 13		Publish Date	Jul. 03, 2018	

● **FUNCTIONS**

Omni-directional Vibration Detecting

● **APPLICATIONS**

1. Wake up systems for power saving,
Such like remote controllers
2. GPS starting system
3. Alarm system
4. Anti-theft, Anti-tampered devices.
5. Automatically flashing for bike lamp
6. Subsidiary night lamp flashing for car
7. Outsole of sporting shoes flashing
8. Toys

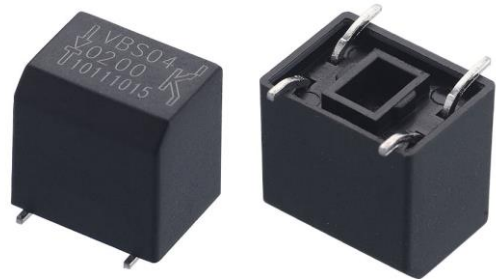

● **FEATURES**

1. Housing made of high insulation plastic material, free from electric conduction and rust problem.
2. Detecting with photo transistors, generating highly reliable and stable signals.
3. All plastic materials subject to industrial purpose, resist high temperature and meet fireproof function.
4. Simple ON and OFF signals, easy for design.
5. Both suitable for vertical and horizontal PCB.
6. RoHS compliance, an ideal substitute for mercury switch.
7. A more economical vibration detection option than IC design solution.
8. All made in Taiwan and examined before shipment.

● **PATENTS**

1. Taiwan Patent No. I 226467
2. U.S.A. Patent No. US 6,740,867 B2
3. China Patent No. ZL 02146662.9



Tilt Sensor Switch

Item No.	VBS040200T	Description	Photoelectric	Version	9
Page	2 of 13		Publish Date	Jul. 03, 2018	

● DIMENSIONS / OPERATION / P.C.B. LAYOUT (Unit: mm, Tolerance: ±0.25mm)

Fig. 1

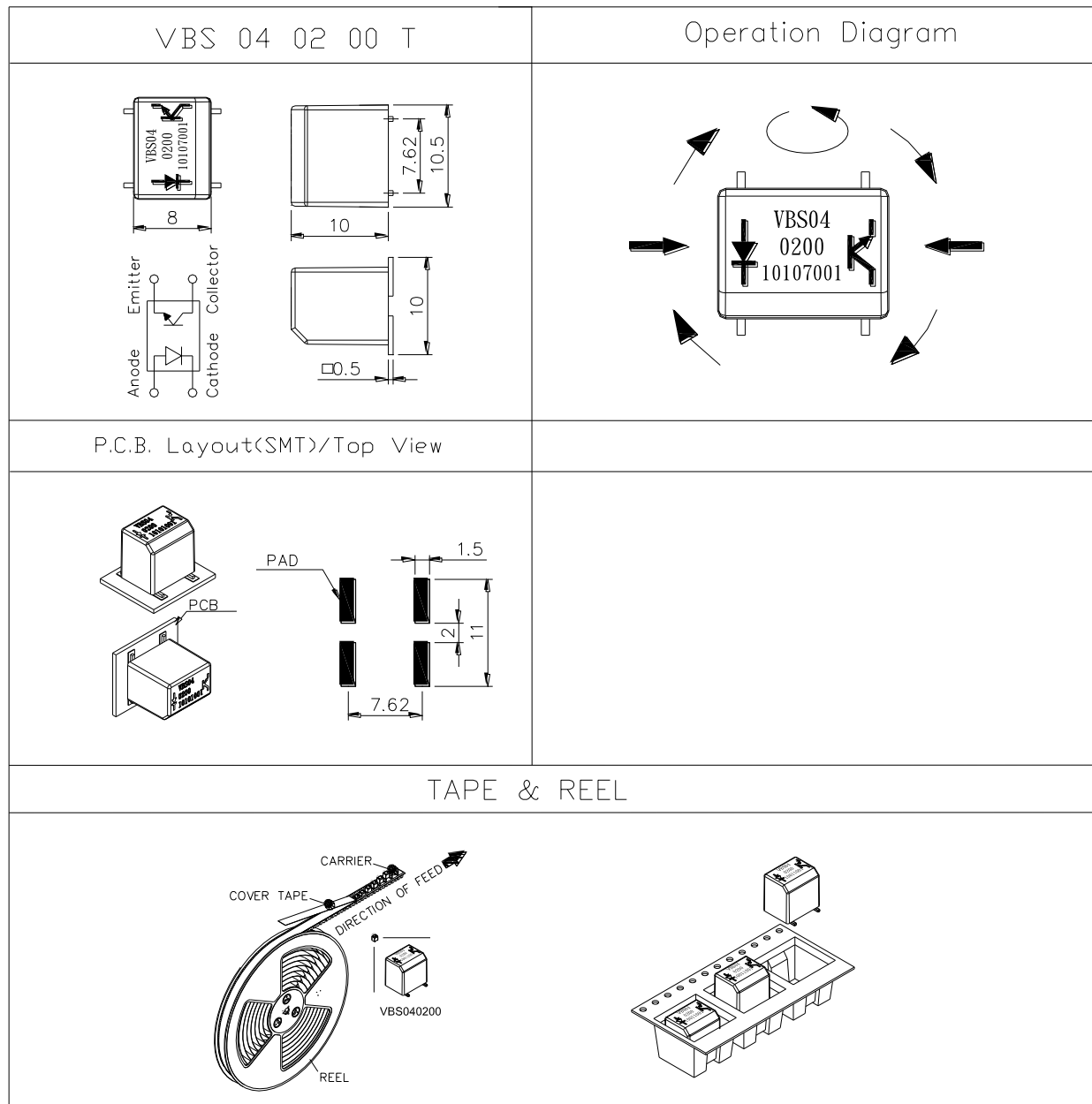

Tilt Sensor Switch

Item No.	VBS040200T	Description	Photoelectric	Version	9
Page	3 of 13		Publish Date	Jul. 03, 2018	

● Absolute Maximum Rating (Ta=25°C)

Item		Symbol	Rating	Unit
Input	Power Dissipation	Pd	75	mW
	Reverse Voltage	V _R	5	V
	Forward Current	I _F	50	mA
	Peak Forward Current (*1)	I _{FP}	1	A
Output	Collector Power Dissipation	P _C	100	mW
	Collector Current	I _C	20	mA
	C-E Voltage	V _{CEO}	30	V
	E-C Voltage	V _{ECO}	5	V
Operating Temperature		T _{opr}	-25~+85	°C
Storage Temperature		T _{stg}	-40~+85	°C
Soldering Temperature (*2)		T _{sol}	260	°C

(*1) tw=100 μSec., T=10 mSec.

(*2) t=5 Sec



Tilt Sensor Switch

Item No.	VBS040200T	Description	Photoelectric	Version	9
Page	4 of 13		Publish Date	Jul. 03, 2018	

● Electrical Optical Characteristics (Ta=25°C)

Parameter	Symbol	Condition	Min.	Typ.	Max.	Unit
Forward Voltage	V_F	$I_F=20mA$	-	1.2	1.5	V
Reverse Current	I_R	$V_R=5V$	-	-	10	μA
Peak Wavelength	λ_p	$I_F=10mA$		940		nm
C-E Saturation Voltage	$V_{CE(sat)}$	$I_C=0.25mA$ $I_F=20mA$	-	-	0.4	V
Light Current	I_C	$V_{CE}=5V$ $I_F=20mA$	0.5	5	22	mA
The variation of light current when vibration	ΔI_C	$V_{CE}=5V$ $I_F=20mA$	-	0.2	-	mA
Rise Time	T_r	$I_C=0.8mA$ $V_{CC}=30V$	-	5	-	μsec
Fall Time	T_f	$R_L=1K\Omega$	-	5	-	μsec



Tilt Sensor Switch

Item No.	VBS040200T	Description	Photoelectric	Version	9
Page	5 of 13		Publish Date	Jul. 03, 2018	

● Schematic Design

In schematic design, we suggest the design current equal to the half of rated current, we get VBS04,

Current of Emitter (IR) $I_F = 10 \text{ mA}$

Current of Receiver (PT) $I_c = 0.25 \sim 11.0 \text{ mA}$

When vibration, the varied current at Receiver (PT) $\Delta I_c \approx 0.1 \text{ mA}$

Adjustment of the input divided voltage of LM393 (pin3), the sensitivity is adjusted.

● Schematic 1 (Power supply for 3.3V)

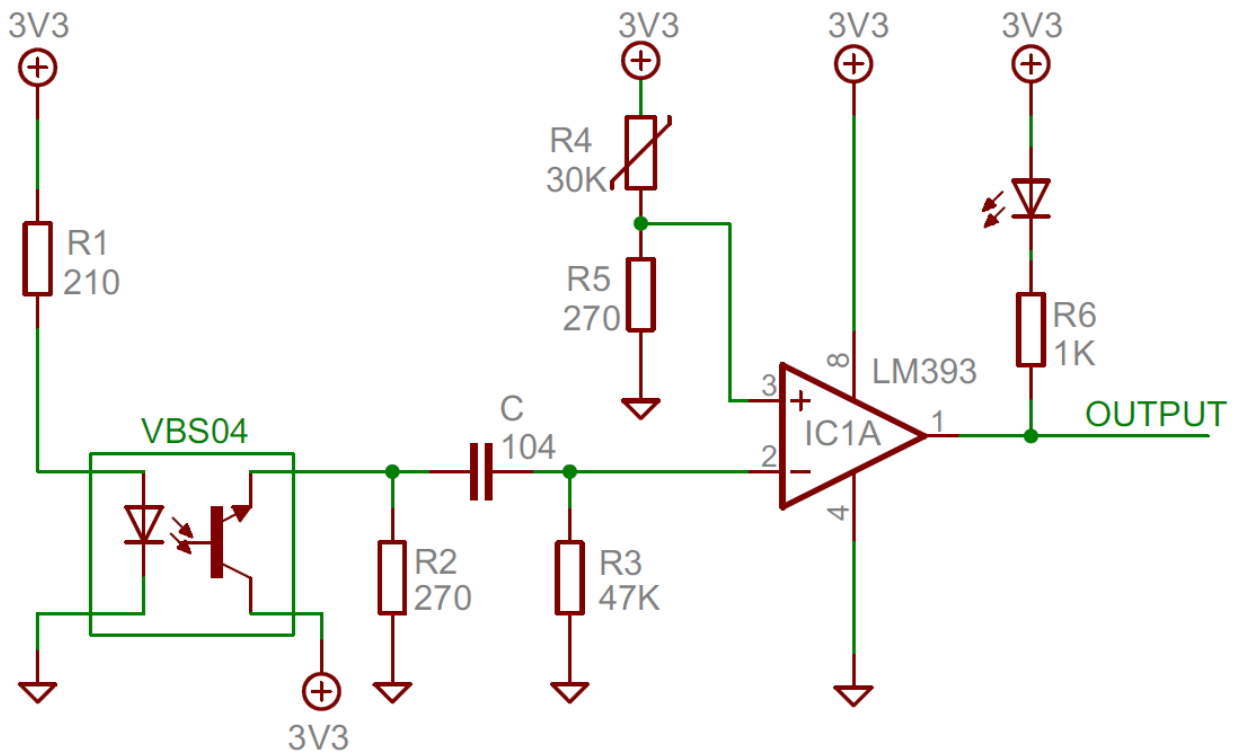

Tilt Sensor Switch

Item No.	VBS040200T	Description	Photoelectric	Version	9
Page	6 of 13		Publish Date	Jul. 03, 2018	

● Schematic 2 (Power supply for 5V)

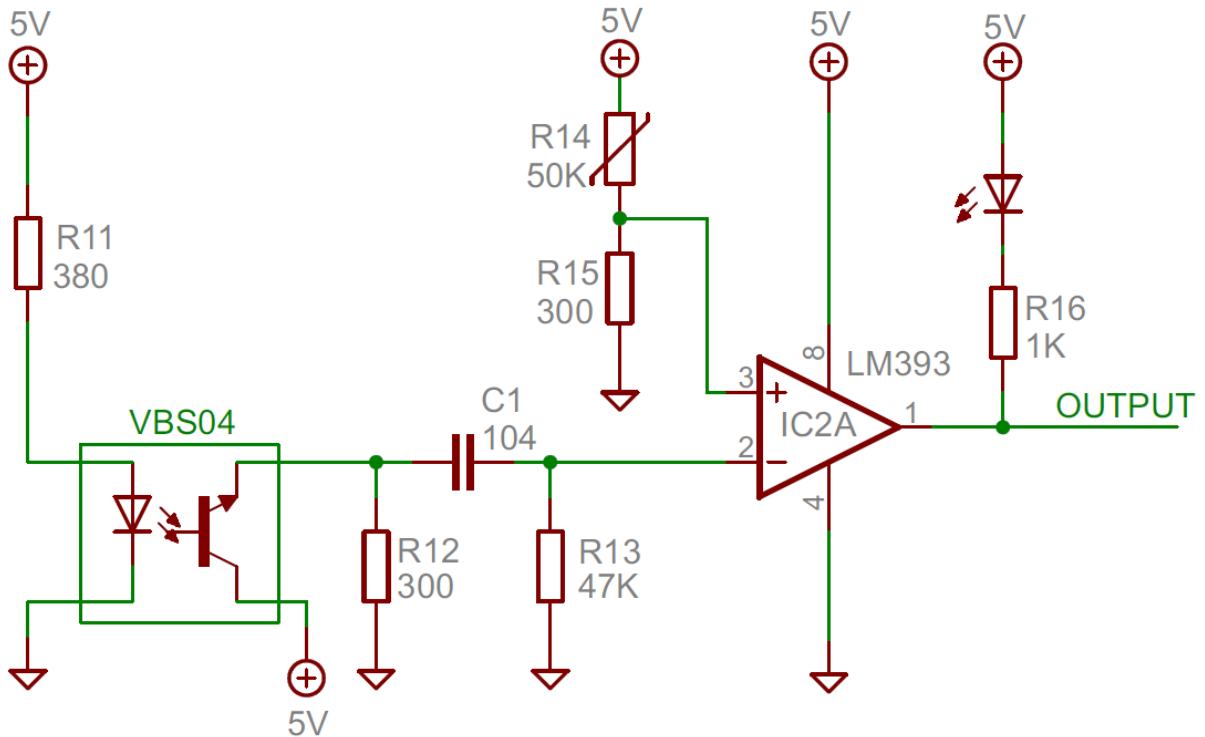

Tilt Sensor Switch

Item No.	VBS040200T	Description	Photoelectric	Version	9
Page	7 of 13		Publish Date	Jul. 03, 2018	

● Typical Electrical / Optical Characteristics Curves (Ta=25°C)

Fig.1 Power Dissipation vs. Ambient Temperature

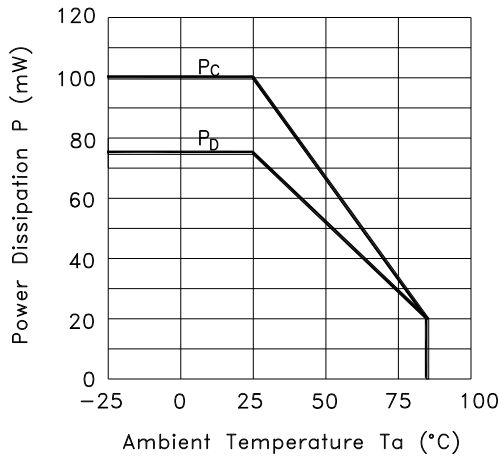

Fig.2 Forward Current vs. Forward Voltage

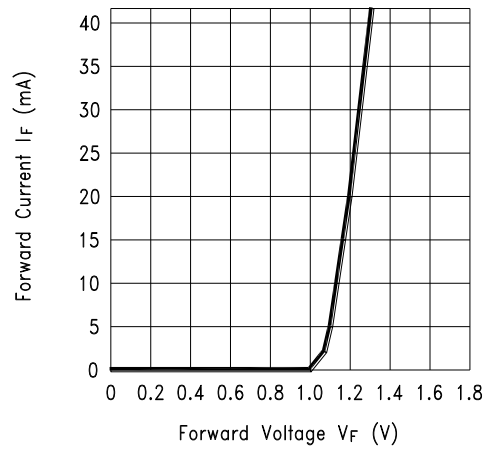

Fig.3 Collector Current vs. Collector-emitter Voltage

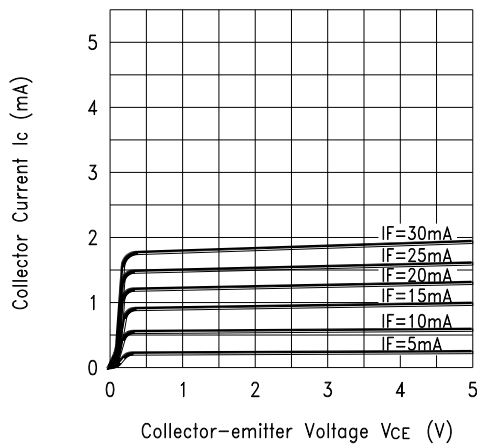
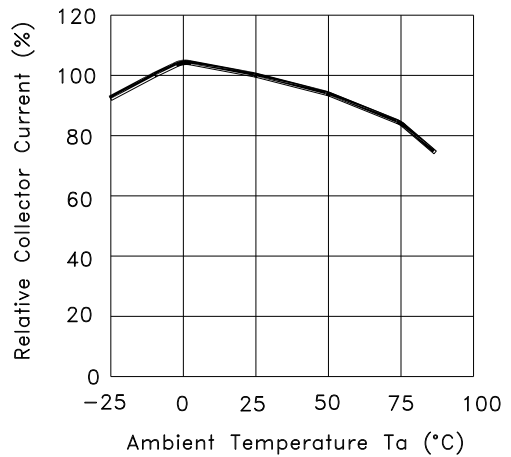

Fig.4 Collector Current vs. Ambient Temperature



Tilt Sensor Switch

Item No.	VBS040200T	Description	Photoelectric	Version	9
Page	8 of 13		Publish Date	Jul. 03, 2018	

Fig.5 Collector-emitter Saturation Voltage vs. Ambient Temperature

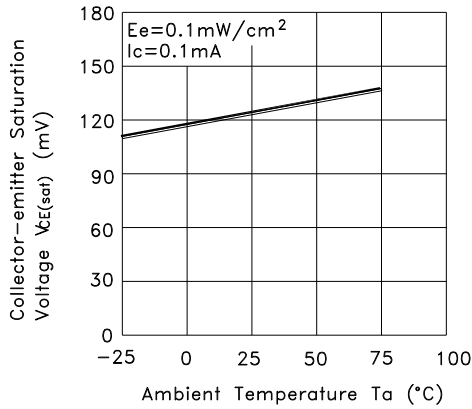

Fig.6 Response Time vs. Load Resistance

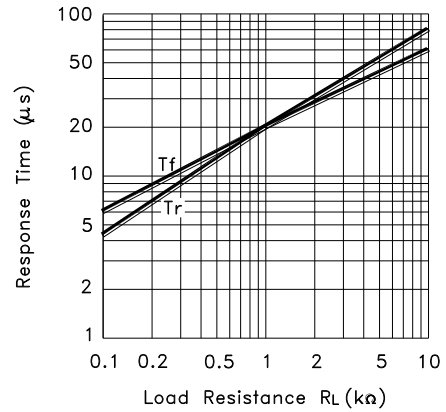
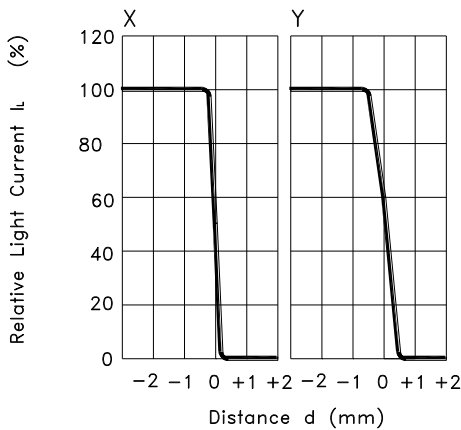
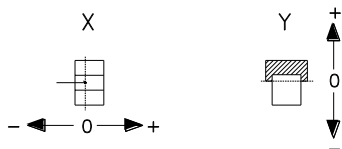

Fig.7 Sensing Position Characteristics (Typical)



(Center of Optical axis)



Test Circuit for Response Time

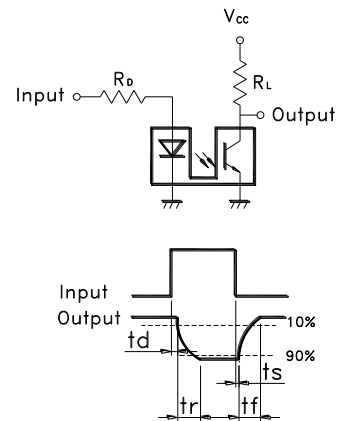

Tilt Sensor Switch

Item No.	VBS040200T	Description	Photoelectric	Version	9
Page	9 of 13		Publish Date	Jul. 03, 2018	

● **RELIABLE TEST ITEMS**

Reliable Test for VBS040200T

	Test Item	Contents
1	IR Reflow	Peak temp.=255~260°C
2	Operating Temperature	-25°C ~ 85°C
3	Storage Temperature	-40°C ~ 85°C
4	Humidity	40 °C / 95 %RH
5	Mechanical Life	2Hz, horizontal 1,000,000 times
6	Electrical Life	I _F =20 mA, V _{CE} =5 V TIME: 30,000 hrs

● **SOLDERING CONDITION**

Following soldering conditions are for reference only, please use soldering information that solder paste manufacturer recommends.

Condition	Soldering Temperature	Soldering Time	Wattage of Manual Soldering	Type
Suitable Production Process				
IR Reflow	Please refer to following < Table of classification Reflow profile > and Fig. 2		-	SMD
Manual Soldering	300±5°C	< 3 seconds max.	30W or Temperature-controlled manual soldering	SMD



Tilt Sensor Switch

Item No.	VBS040200T	Description	Photoelectric	Version	9
Page	10 of 13		Publish Date	Jul. 03, 2018	

< Table of classification Reflow profile >

Item	Pb process	Pb free process
Pre-heat and Soak		
Temperature min.(T _{min})	100°C	150°C
Temperature max.(T _{max})	150°C	200°C
Time (T _{min} to T _{max})(t _s)	60-120 seconds	60-120 seconds
Average ram-up Rate (T _{max} to T _p)	3°C/second max.	3°C/second max.
Liquidous Temperature (TL)	183°C	217°C
Time at Liquidous (t _L)	60-150 seconds	60-150 seconds
Peak package body Temperature (T _p)*	230°C ~235°C *	255°C ~260°C *
Classification temperature(T _c)	235°C	260°C
Time(tp)** within 5 °C of the specified classification temperature (T _c)	20** seconds	30** seconds
Average ram-down Rate (T _p to T _{max})	6°C/second max.	6°C/second max.
Time 25 °C to peak temperature	6 minutes max.	8 minutes max.
* Tolerance for peak profile temperature (T _p) is defined as a supplier minimum and a user maximum.		
** Tolerance for time at peak profile temperature (tp) is defined as a supplier minimum and a user maximum.		



Tilt Sensor Switch

Item No.	VBS040200T	Description	Photoelectric	Version	9
Page	11 of 13		Publish Date	Jul. 03, 2018	

Fig. 2

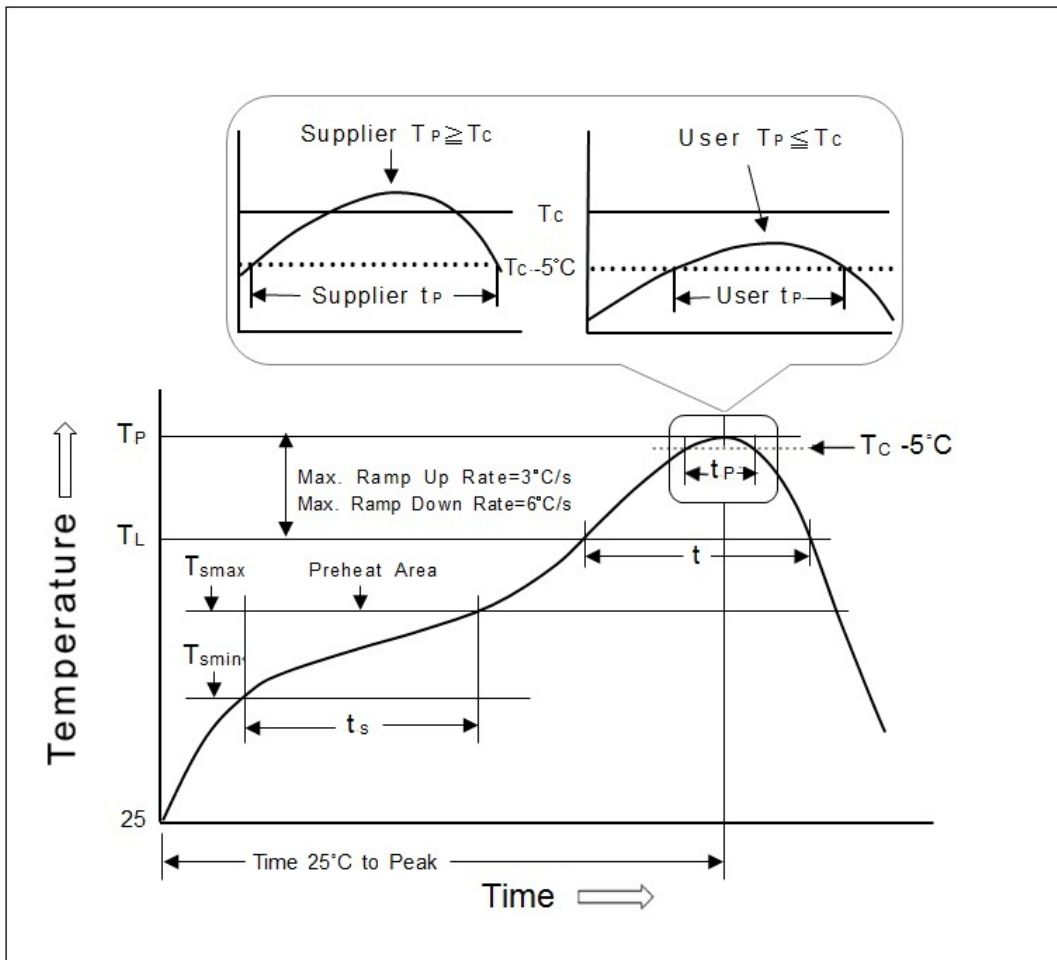

Tilt Sensor Switch

Item No.	VBS040200T	Description	Photoelectric	Version	9
Page	12 of 13		Publish Date	Jul. 03, 2018	

● PACKAGE

	Part Number	Package	Quantity	Total	Dimension(mm)
1.	VBS040200T	Tape & reel	350 pcs	350 pcs	φ330*25H
		Inner box	2 Reels	700 pcs	355L*340W*68H
		Carton	10 boxes	7,000 pcs	703L*364W*380H

※ Package shown as below for reference.

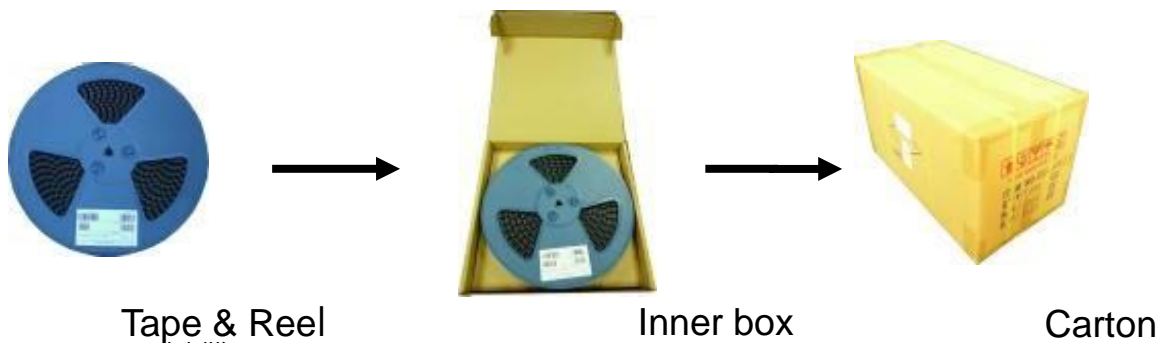

Tilt Sensor Switch

Item No.	VBS040200T	Description	Photoelectric	Version	9
Page	13 of 13		Publish Date	Jul. 03, 2018	

● **NOTES**

1. Suggestion for usage: For vibration usage or application, we suggest to add hysteresis for IC.
2. For the continued product improvement as one of the company policy, specifications may change or update without notice. The latest information can be obtained through our sales offices. Normally, all products are supplied under our standard conditions.

● **PRECAUTIONS FOR USE**

1. If the products is intended to be used for other endurance equipment requiring higher safety and reliability such as life support system, space and aviation devices, disaster and safety system, it's necessary to make verification of conformity or contact us for the details before using.
2. Do not try to clean the switch with a solvent or similar substance after the soldering process.
3. Use water-soluble flux may damage the switch.
4. Please follow the soldering instruction accordingly, otherwise might lead to defective.
5. Do not use switch in the environment of high humidity, because such an environment may cause the leakage current between the terminals.
6. Please do not exceed the rated load as there will be a risk of disabling the product function.
7. In the circuit, switch should not be near or directly connected with the magnetic component solder joints (for example: relays, transformers, etc.).
8. To prevent damaging IR and PT, please make electrostatic protective treatment, for example: wearing a conductive wrist strap or antistatic gloves during production process, grounding machinery etc.

