

AUIR3242S

LOW QUIESCENT CURRENT BACK TO BACK MOSFET DRIVER



Features

- Very low quiescent current on and off state
- Back to back configuration
- Boost converter with integrated diode
- Standard level gate voltage
- Input active low
- Under voltage lockout with diagnostic
- Wide operating voltage 3-36V
- Ground loss protection
- Lead-Free, Halogen Free, RoHS compliant

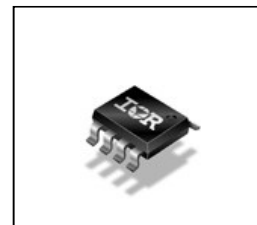

Potential applications

- Power switch for Stop and Start board net stabilizer
- Battery switch

Product validation

Base Part Number	Package Type	Standard Pack		Complete Part Number
		Form	Quantity	
AUIR3242S	SOIC8	Tape and reel	2500	AUIR3242STR

Description

The AUIR3242S is a high side MOSFET driver for back to back topology targeting back to back switch. It features a very low quiescent current both on and off state. The AUIR3242S is a combination of a boost DC/DC converter using an external inductor and a gate driver. It drives standard level MOSFET even at low battery voltage. The input controls the gate voltage. The AUIR3242S integrates an under voltage lock out protection to prevent to drive the MOSFET in linear mode.

Table of contents

Table of contents	2
1 Typical Connection	3
2 Block diagram	5
2.1 Input Circuitry.....	5
2.2 Current definition.....	6
3 Pin configuration	7
3.1 Pin assignement.....	7
3.2 Pin definition and functions.....	7
4 General product characteristics	8
4.1 Absolute Maximum Ratings	8
5 Static Electrical Characteristics	9
6 Timing Converter Characteristics	10
6.1 Timing converter definition	10
7 Switching Characteristics	11
8 General Description	12
8.1 Boost DC/DC converter	12
8.2 Low quiescent current operation when “On”	12
8.3 Peak current control	13
8.4 Output capacitor choice	14
8.5 Minimum operating voltage.....	14
8.6 Over-Voltage protection.....	14
8.7 Under voltage lockout - Diagnostic	14
8.8 Analog Diagnostic: Output current measurement.....	16
8.9 Digital diagnostic.....	16
8.10 Power On Reset	17
9 Typical Performance Characteristics	18
10 Case Outline – SO8	20
11 Tape & Reel SO8	21
12 Part Marking Information	22
13 Revision history	24

1 Typical Connection

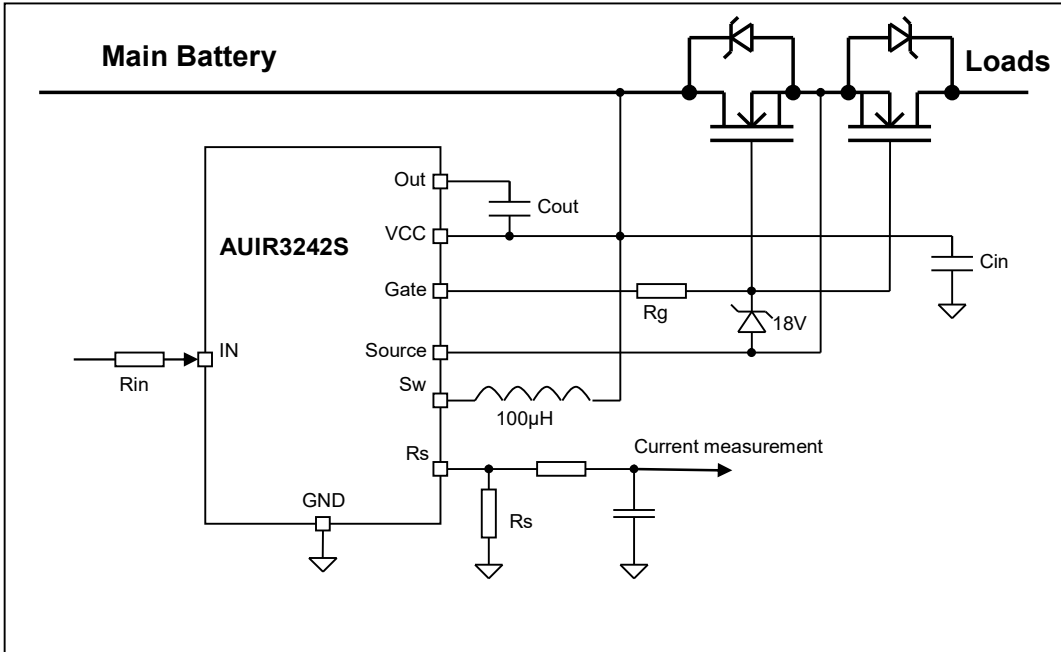

Figure 1 Back to back configuration

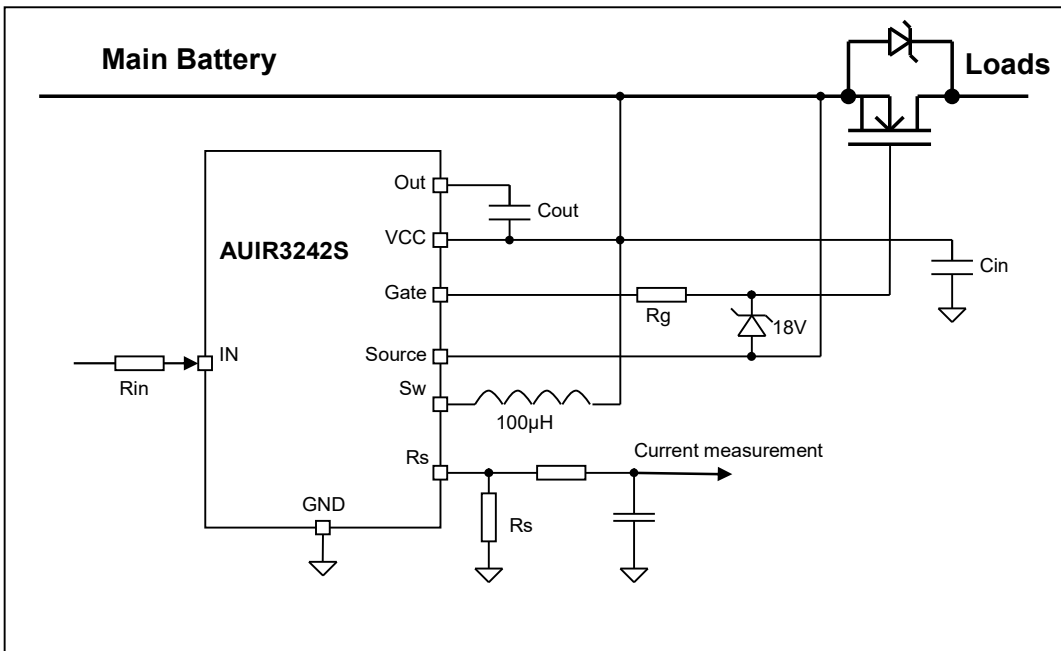

Figure 2 Q diode configuration

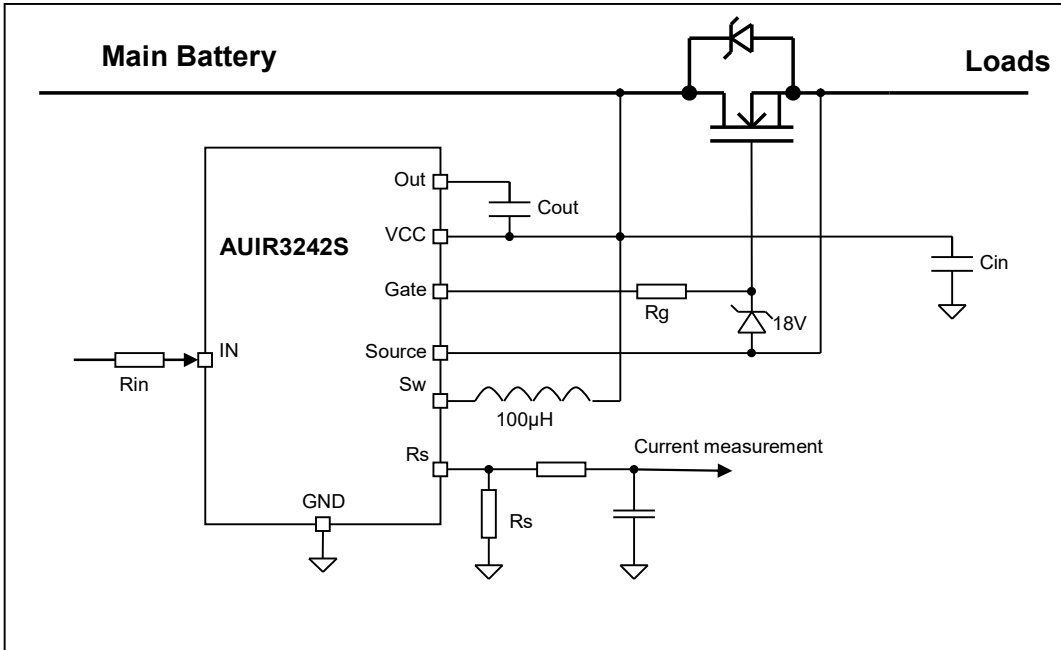

Figure 3 Battery switch configuration

2 Block diagram

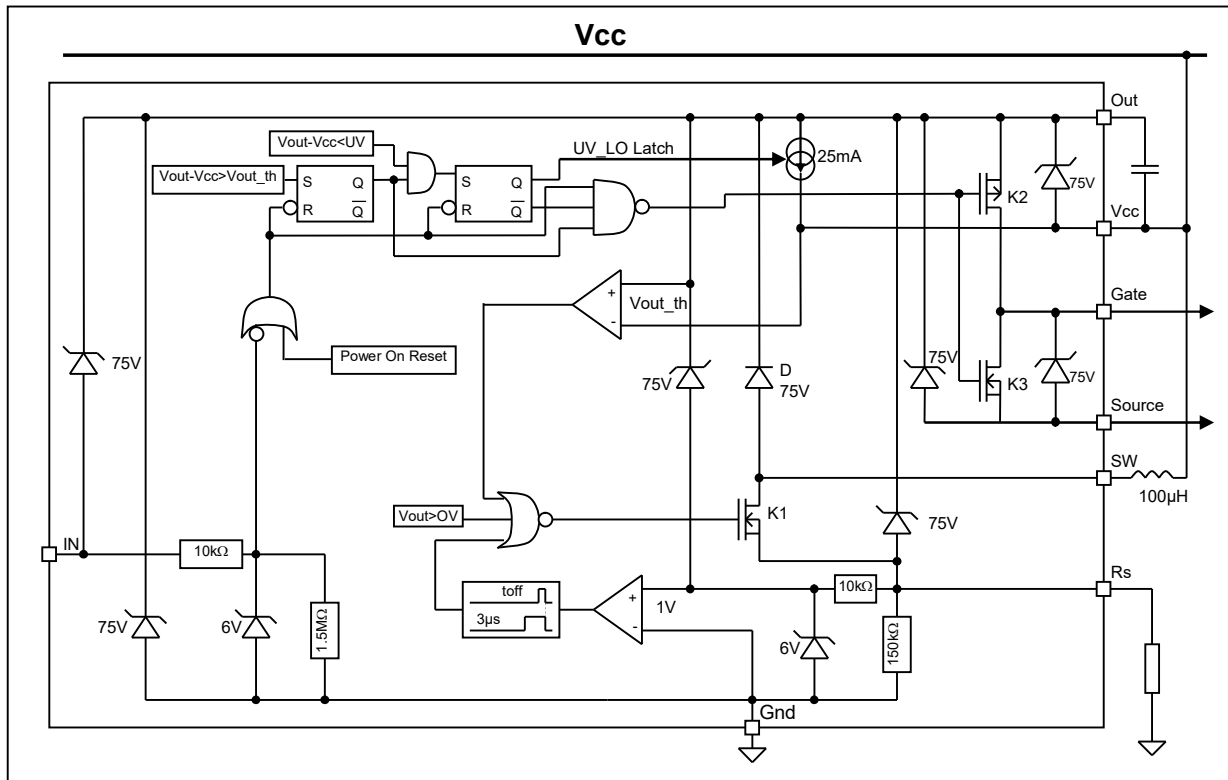

Figure 4 Block diagram AUIR3242S

2.1 Input Circuitry

The input control circuitry drives the output gate driver stage. The input is active low. With a high level input voltage, the gate is shorted to the source. With a low level input, the output gate driver turn on when V_{out} reaches 12.5V.

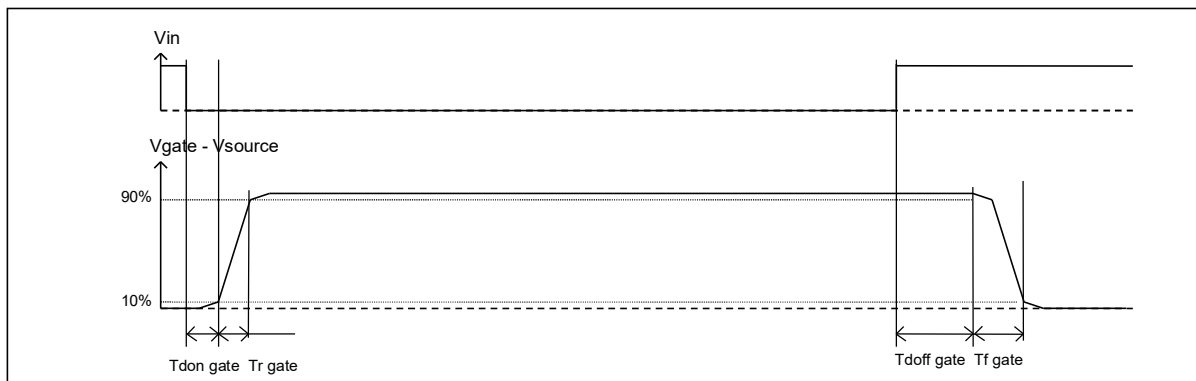

Figure 5 Input circuitry

2.2 Current definition

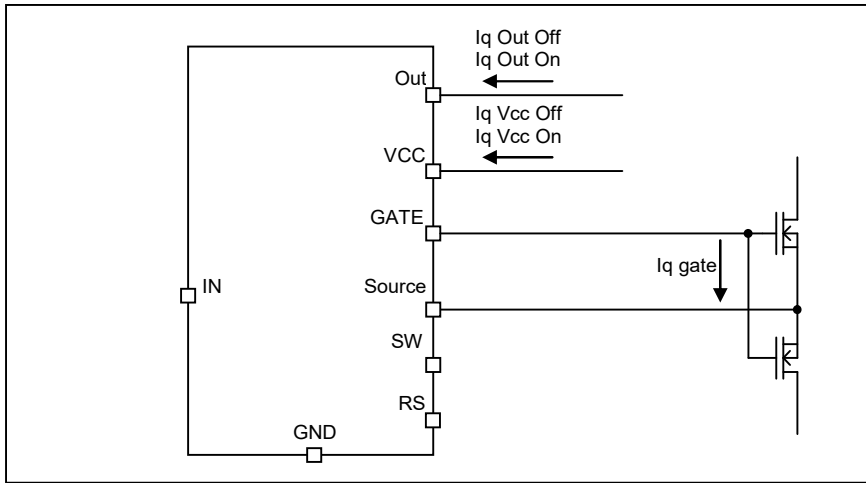

Figure 6 Current definition

3 Pin configuration

3.1 Pin assignment

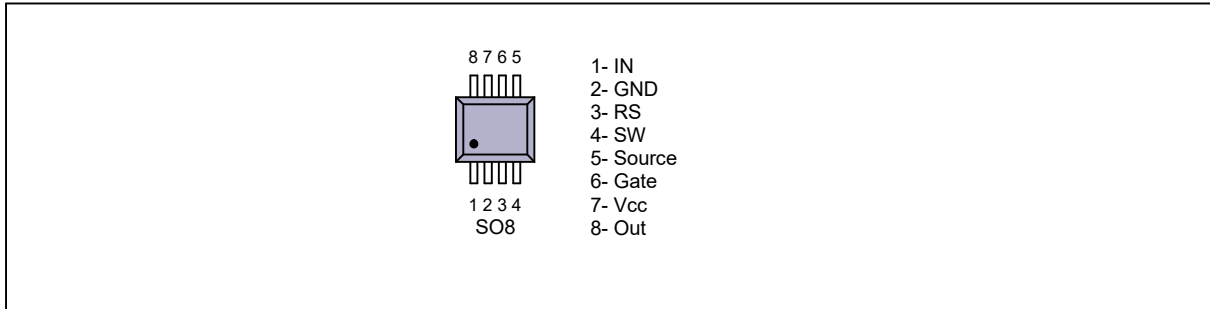

Figure 7 Pin assignment of AUIR3242S

3.2 Pin definition and functions

Table 1 Pin configuration AUIR3242S

Pin number	Symbol	Description
1	IN	Input pin
2	GND	Ground pin
3	RS	Current sense input pin
4	SW	Output of K1
5	SOURCE	Connection of the source pin of the Mosfets
6	Gate	Output of the gate driver
7	VCC	Power supply
8	OUT	Output of the boost converter

4 General product characteristics

4.1 Absolute Maximum Ratings

Table 2 Absolute maximum ratings

Absolute maximum ratings indicate sustained limits beyond which damage to the device may occur.

Symbol	Parameter	Min.	Max.	Units
Vcc-gnd	Maximum Vcc voltage	-0.3	65	V
Vsw-gnd	Maximum Sw voltage	Vrs-0.3	Vout+Vf	V
Vsw-Vrs	Maximum Sw voltage	-0.3	65	V
Vout-Vcc	Maximum Vout-Vcc voltage	-0.3	65	V
Vout-gnd	Maximum Vout voltage	-0.3	65	V
Vout-Vgate	Maximum Vout-Vgate voltage	-0.3	65	V
Vgate-Vsource	Maximum Vgate-Vsource voltage	-0.3	75	V
Vout-Vsource	Maximum Vout-Vsource voltage	-0.3	75	V
Vrs-gnd	Maximum Rs pin voltage	-0.3	6	V
Vin-gnd	Maximum IN pin voltage	-0.3	Vout+0.3	V
Isw	Maximum continuous current in Sw pin	—	200	mA
ID	Maximum continuous current in the rectifier diode	—	200	mA
Rg	Minimum gate resistor	100	—	Ohms
Tj max.	Maximum operating junction temperature	-40	150	C°
	Maximum storage temperature	-55	150	C°

Table 3 Thermal Characteristic

Symbol	Parameter	Min.	Max.	Units
Rth	Thermal resistance junction to ambient	100	—	°C/W

Table 4 Recommended Operating Conditions

Symbol	Parameter	Min.	Max.	Units
VIH	High level input voltage	2.5	5.5	V
VIL	Low level input voltage	0	0.8	V

5 Static Electrical Characteristics

T_j=-40..125°C, V_{cc}=6..16V (unless otherwise specified), typical value are given for V_{cc}=14V and T_j=25°C

Table 5 Static electrical characteristics

Symbol	Parameter	Min.	Typ.	Max.	Units	Test condition		
V _{cc op} (ext).	Supply voltage range for extended operation (some parameters may be downgraded beyond nominal operation)	3	—	36	V	See page 13		
V _{cc op} (nom). ⁽¹⁾	Supply voltage range for nominal operation	6	—	16				
I _{q Vcc Off} (2)	Supply current when Off, T _j =25°C	—	2	6	μA	V _{in} =0V, K1/K2 off, K3 on, V _{out} -V _{cc} =14V		
	Supply current when Off, T _j =125°C	—	3	8				
I _{q Vcc On} (2)	Supply current when On, T _j =25°C	—	3	6				
	Supply current when On, T _j =125°C	—	4	8				
I _{q Out Off} (2)	Quiescent current on Out pin, T _j =25°C	—	10	15				
	Quiescent current on Out pin, T _j =125°C	—	13	25				
I _{q Out On} (2)	Quiescent current on Out pin, T _j =25°C	—	12	20				
	Quiescent current on Out pin, T _j =125°C	—	15	30				
V _{br Out}	Breakdown voltage between Out and Source	75	90	—			V	I=10mA
V _{br Gate}	Breakdown voltage between Gate and Source	75	90	—				I=10mA
OV	Over-voltage protection between V _{out} and Gnd	50	55	62				
I _{in}	Input current	—	3	6	μA	V _{in} =5V		
V _{in_th}	Input voltage threshold	0.8	1.5	2.5	V			
V _{out_th}	Output voltage threshold	11.5	12.5	14				
UV_LO	Undervoltage lockout between V _{out} and V _{cc}	6.5	8	10		See figure 12		
V _{out_th} -UV_LO	Output voltage minus Undervoltage lockout threshold	3	4.5	—				
V _{rs th}	R _s threshold	0.8	1	1.3				
I _{latch UV_LO}	Under voltage lockout Latch current between V _{out} and V _{cc}	10	25	40	mA	See page 13		
V _f	Forward voltage of rectifier diode	—	0.9	1.1	V	I=100mA, T _j =25°C		
R _{dson K1}	R _{dson} of K1, T _j =-40°C	—	8	13	Ω	I=100mA, V _{out} -V _{cc} =12.5V		
	R _{dson} of K1, T _j =25°C	—	11	15				
	R _{dson} of K1, T _j =125°C	—	15	20				
R _{dson K2}	R _{dson} of K2, T _j =25°C	—	25	—		I=100mA		
R _{dson K3}	R _{dson} of K3, T _j =25°C	—	25	—				

(1) If the part is supply outside of this range (ex: during ramp up of V_{cc}), other values in this table might not be guaranteed

(2) Supply current might be higher than specified during the start-up of the part (especially during the charge of C_{out})

6 Timing Converter Characteristics

$T_j = -40..125^\circ\text{C}$, $V_{cc} = 6..16\text{V}$ (unless otherwise specified), typical value are given for $V_{cc} = 14\text{V}$ and $T_j = 25^\circ\text{C}$.

Table 6 Timing converter characteristics

Symbol	Parameter	Min.	Typ.	Max.	Units	Test condition
T_{off}	Off time	2	3	4	μS	See figure 8
$T_{don\ K1}$	Turn-on delay of K1	—	5	—		See figure 9
$T_{doff\ K1}$	Turn-off delay of K1	—	0.2	—		See figure 9
POR_Delay	Power On Reset delay	200	500	1200	V	See figure 15
POR_Th	Power On Reset threshold	6	6.5	7.5		

6.1 Timing converter definition

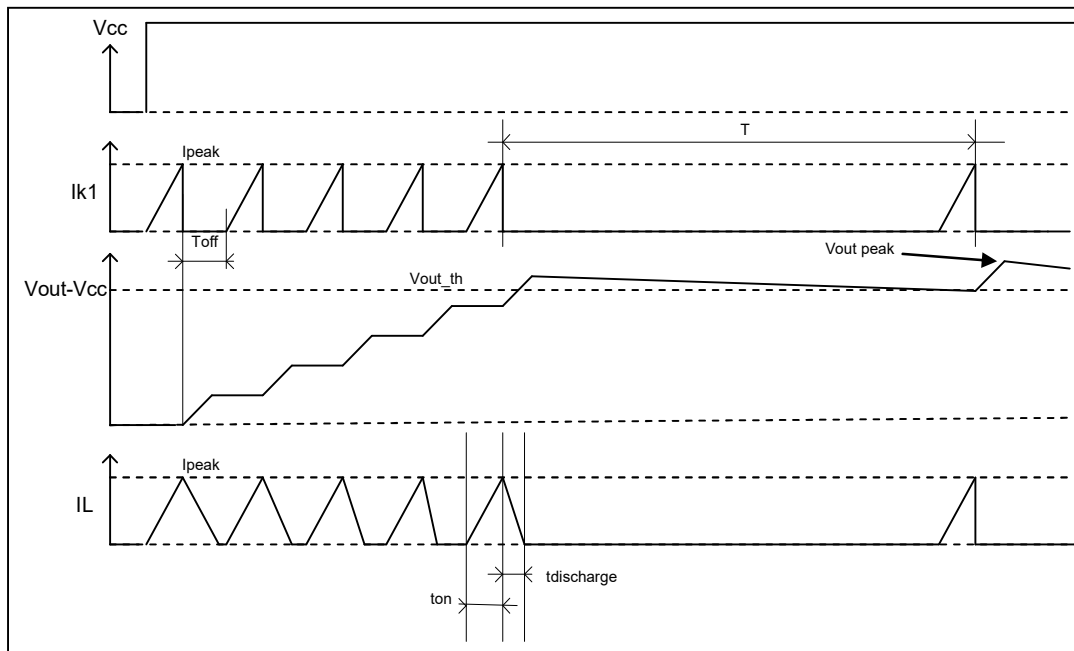

Figure 8

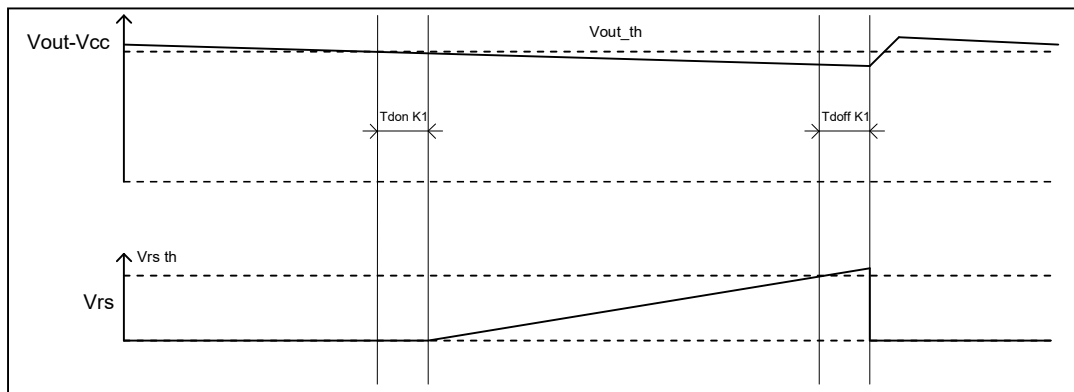

Figure 9

7 Switching Characteristics

T_j=-40..125°C, V_{cc}=6..16V (unless otherwise specified), typical value are given for V_{cc}=14V and T_j=25°C.

Table 7 Switching characteristics

Symbol	Parameter	Min.	Typ.	Max.	Units	Test condition
T _{don gate}	Turn-on delay	0.5	2	5	μs	C _{gate} =100nF
T _{r gate}	Rise time on gate 10% to 90% of V _{out} -V _{cc}	—	6	15		
I _{gate+}	Gate high short circuit pulsed current	100	350	—	mA	V _{gate} -V _{source} =0V
T _{doff gate}	Turn-off delay	0.5	1.5	3	μs	C _{gate} =100nF
T _{f gate}	Fall time on gate 90% to 10% of V _{out} -V _{cc}	—	6	15		
I _{gate-}	Gate low short circuit pulsed current	100	350	—	mA	V _{gate} -V _{source} =14V
T _{reset}	Time to reset the under voltage latches	—	1	100	μs	See page 13

8 General Description

8.1 Boost DC/DC converter

The topology of the AUIR3242S is a boost DC/DC converter working in current mode. The DC/DC is working once the AUIR3242S is powered regardless the input level.

K1 is switched on when the gate voltage is lower than Vout threshold. When Rs pin reaches Vrs th, K1 is turned off and the inductor charges the Out capacitor through D. The system cannot restart during Toff after Vrs th has been reached. The DC/DC restart only when the Out and the Vcc voltage difference is lower than Vout_th in order to achieve low quiescent current on the power supply.

To turn off the power MOSFET, the input must be low. Then K2 is turned off and K3 shorts the gate to the source.

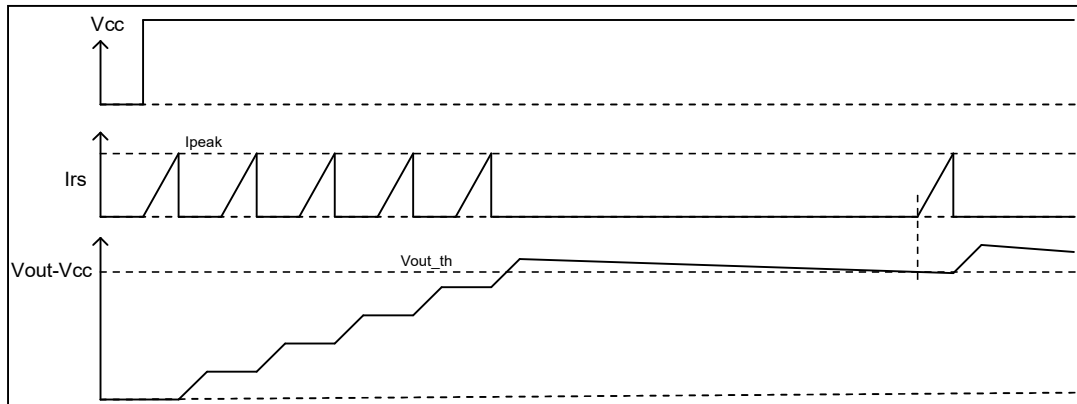

Figure 10

8.2 Low quiescent current operation when “On”.

The AUIR3242S is able to operate with a very low quiescent current on the Vcc pin. Nevertheless the supply current depends also on the leakage of the power MOSFET named “Iq gate” on the diagram below.

The leakage current is given when K1 is off. When K1 is on, the current flowing in Vcc is the current charging the inductor. Therefore the average current on the Vcc is the combination of the current when K1 is ON and OFF. The average current on the Vcc pin can be calculated using:

$$I_{Vcc \text{ average on}} = (I_{q \text{ gate}} + I_{q \text{ Out On}}) * \frac{V_{out} - V_{cc} + V_f}{V_{cc}} + I_{q \text{ Vcc on}} + I_{q \text{ Out on}}$$

$$I_{Vcc \text{ average off}} = (I_{q \text{ gate}} + I_{q \text{ Out Off}}) * \frac{V_{out} - V_{cc} + V_f}{V_{cc}} + I_{q \text{ Vcc off}} + I_{q \text{ Out off}}$$

With Vout: the average voltage on the output.

$$V_{out \text{ average}} = (V_{out \text{ peak}} + V_{out \text{ th}})/2$$

Vout peak can be calculated by:

$$V_{out \text{ peak}} = \sqrt{\frac{L}{C_{out}} \cdot I_{peak}^2 + V_{out \text{ th}}^2}$$

During On operation, the DC/DC works in pulse mode, meaning each time the Vout-Vcc voltage comes below 12.5V, the AUIR3242S switches on K1 to recharge the gate voltage. When the lout leakage is low enough to maintain the DC/DC in discontinuous mode, the frequency is calculate by:

$$T = \frac{I_{peak}^2 * L}{2 * (I_{q \text{ gate}} + I_{q \text{ Vout on}}) * (V_{out} - V_{cc} + V_f)}$$

8.3 Peak current control

The current in the inductor is limited by the 1V comparator which monitors the voltage across Rs. Due to the delay in the loop (tdoff K1), the inductor current will exceed the threshold set by: $\frac{V_{rsth}}{R_s}$

At low voltage, the current waveform in the inductor is not anymore linear, but exponential because the sum of the resistor of K1, the inductor and RS are not any more negligible.

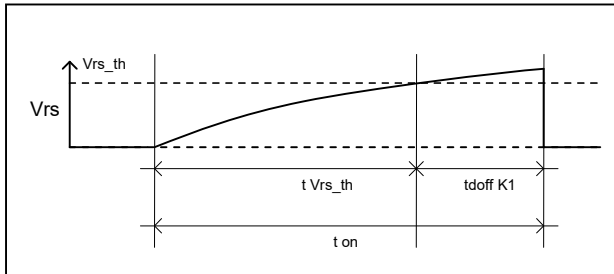

Figure 11

The peak current and ton can be calculated as follow:

$$t_{Vrsth} = - \frac{L}{R_{don \ k1} + R_s + R_l} * \ln \left(1 - \frac{R_s + R_{dson \ k1} + R_l}{V_{rs_th} * R_s * V_{cc}} \right)$$

Where Rl is the resistor of the inductor

With: $t_{on} = t_{Vrs_th} + t_{doff \ K1}$

The peak current can be solved by:

$$I_{peak} = \frac{V_{cc}}{R_{dson \ k1} + R_s + R_l} * \left(1 - e^{-t_{on} * \frac{R_{dson \ k1} + R_s + R_l}{L}} \right)$$

The peak current must not exceed the Maximum Rating of Isw.

8.4 Output capacitor choice

The output capacitor must be chosen based on 2 criteria:

- During the turn on of K2, the voltage drop on Cout must not trigger the Under Voltage Lockout due to the gate charge of the Power MOSFET

$$C_{out} > \frac{Q_{gate\ total\ Power\ Mosfet}}{(V_{out_{th}} - UV_{LO})_{Min.}}$$

- When K1 turn off and the inductor is charging Cout, the peak current on the output capacitor must be limited in order to avoid having current flowing in the Gate zener diode:

$$C_{out} > \frac{L * I_{peak}^2_{max}}{V_{z\ min\ gate}^2 - V_{out\ th\ max}^2}$$

Vz min gate is the minimum Zener voltage of the external gate Zener diode.

8.5 Minimum operating voltage

While the AUIR3242S operating voltage is specified between 3V and 36V. The 3V minimum operating voltage is when the Vcc is going down. The minimum voltage is also limited by the fact that the Rs voltage must reach the Vrsth taking account all resistors which limit the inductor current.

$$V_{cc\ min} = \frac{R_{dson\ k1} + R_s + R_l}{R_s} * V_{rsth}$$

8.6 Over-Voltage protection

The AUIR3242S integrates an over-voltage protection in order to protect K1. When Vcc exceed the Over-voltage threshold, the DC/DC is stopped.

8.7 Under voltage lockout - Diagnostic

In order to avoid to drive the Power MOSFET in linear mode, the AUIR3242S features an under voltage lockout. During the turn on, the gate will not be powered until Vout-Vcc reaches Vout th, meaning K2 is off and K3 is on. Then the AUIR3242S powers the gate of the MOSFET. If Vout-Vcc goes below UV_LO, the gate is shorted to the source and the part is latched. A cycle in the input is required to reset the latch. The input must be kept low longer than Treset.

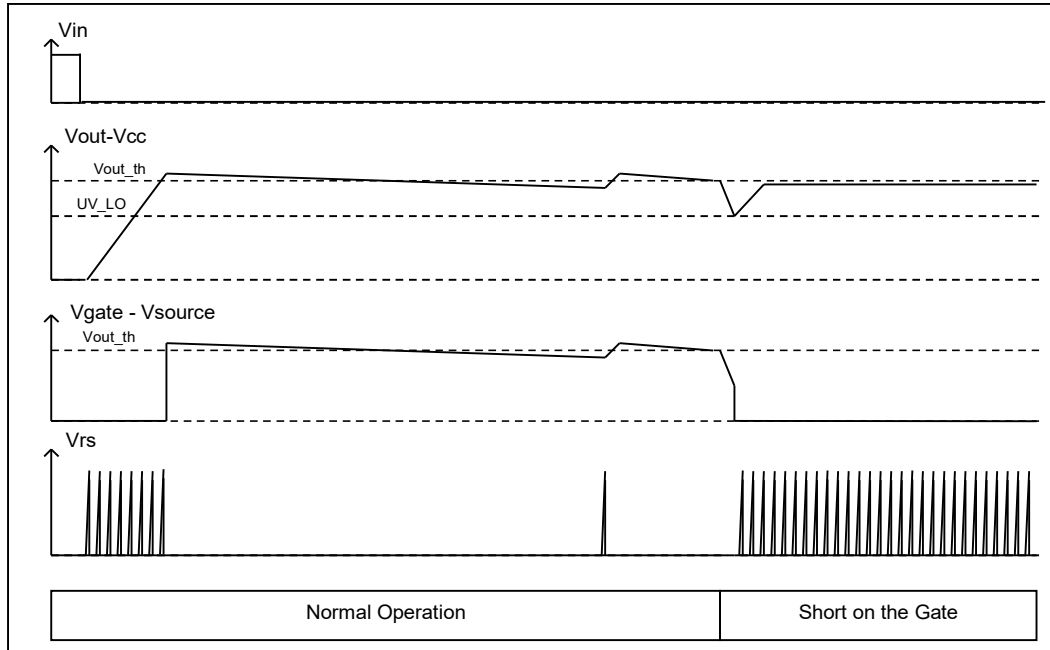

Figure 12

When the part is latched a current source ($I_{latch\ UV_LO}$) is connected between Out and Vcc to increase the current consumption. By monitoring the current consumption the system can have a diagnostic of the output status. The diagnostic can be analog or digital.

8.8 Analog Diagnostic: Output current measurement

The average current into R_s can be measured by adding a low pass filter before the ADC of the micro controller.

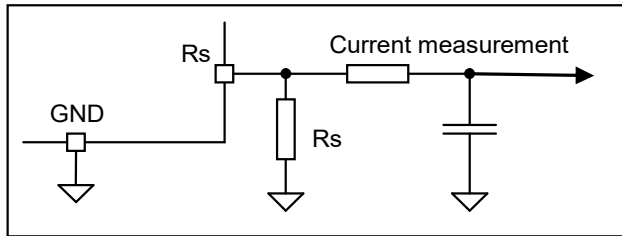

Figure 13

Then the average output current can be evaluated using:

$$I_{out\ av} = I_{Rs\ av} * V_{cc} / (V_{out} - V_{cc})$$

Knowing the output current can be useful to do a diagnostic on the power MOSFET. If the gate is shorted, the output current will be significantly higher than in normal operation.

8.9 Digital diagnostic

By adding a diode during high current consumption mode, the output voltage can be close to 1V. Using a bipolar with a pull-up resistor will provide a digital diagnostic.

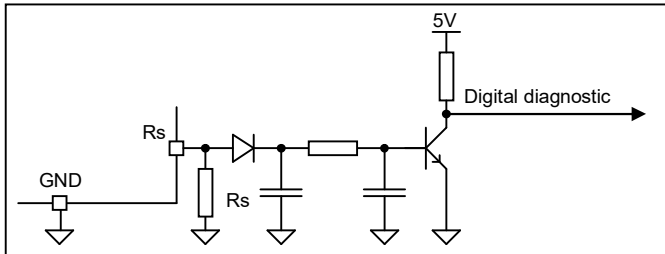

Figure 14

8.10 Power On Reset

During the power on, the AUIR3242S features a Power On Reset to guarantee a stable state of the 2 latches of the Under voltage lockout and guarantee a stable internal biasing. POR_Delay is triggered when $V_{out-Gnd}$ exceeds POR_Th .

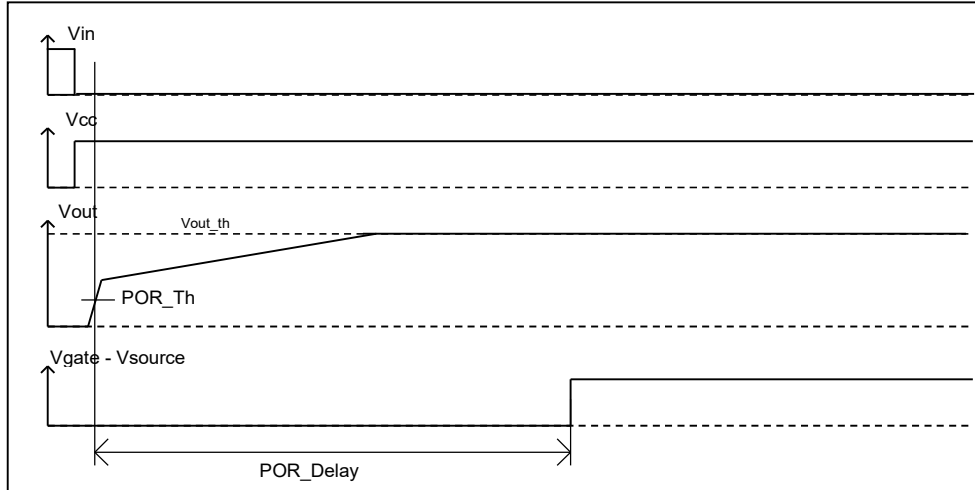

Figure 15

9 Typical Performance Characteristics

Figures are given for typical value, $V_{CC}=14V$ and $T_j=25^{\circ}C$ otherwise specified

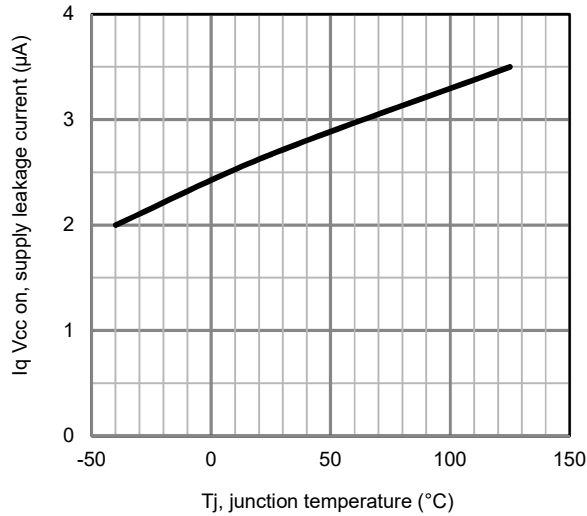

Figure 16 – $I_{q V_{CC} on}$ (μA) Vs T_j ($^{\circ}C$)

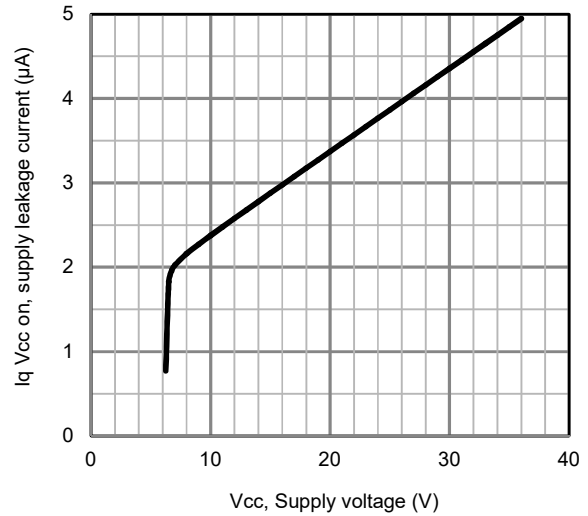

Figure 17 – $I_{q V_{CC} on}$ (μA) Vs V_{CC} (V)

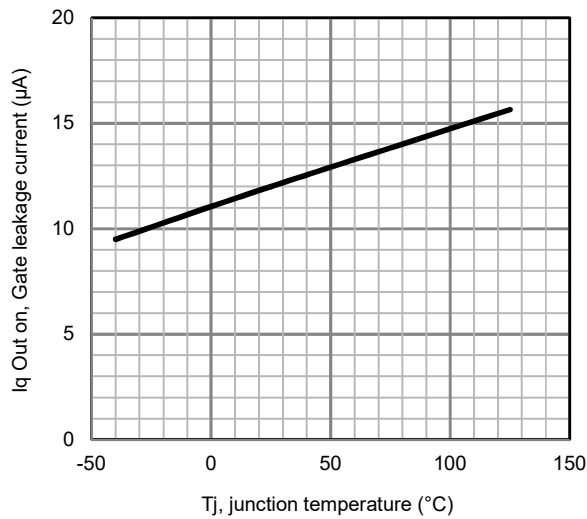

Figure 18 – $I_{q Out on}$ (μA) Vs T_j ($^{\circ}C$)

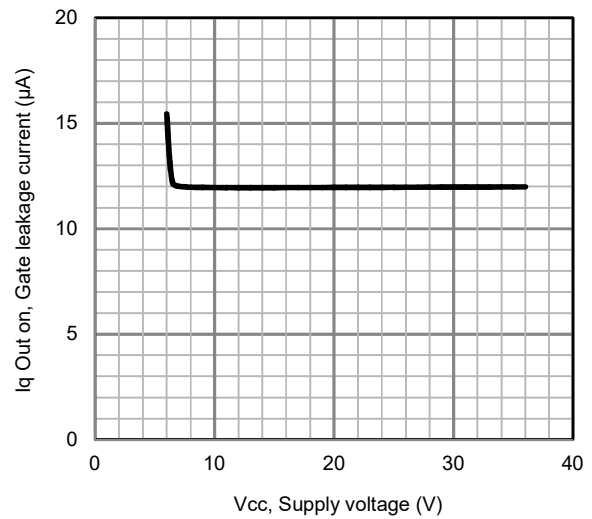

Figure 19 – $I_{q Out on}$ (μA) Vs V_{CC} (V)

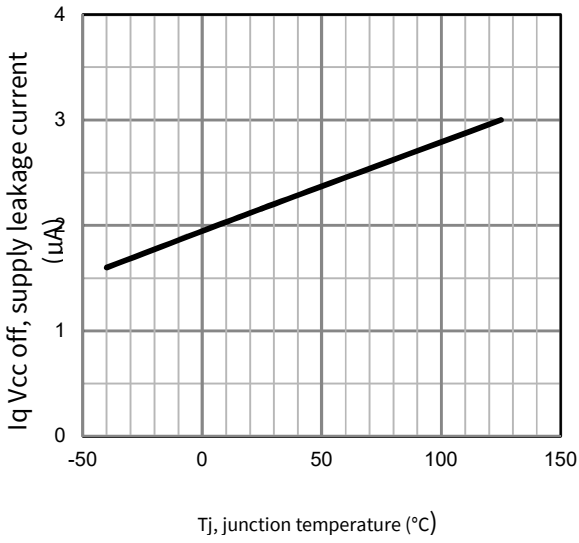

Figure 20 – Iq Vcc off (µA) Vs Tj (°C)

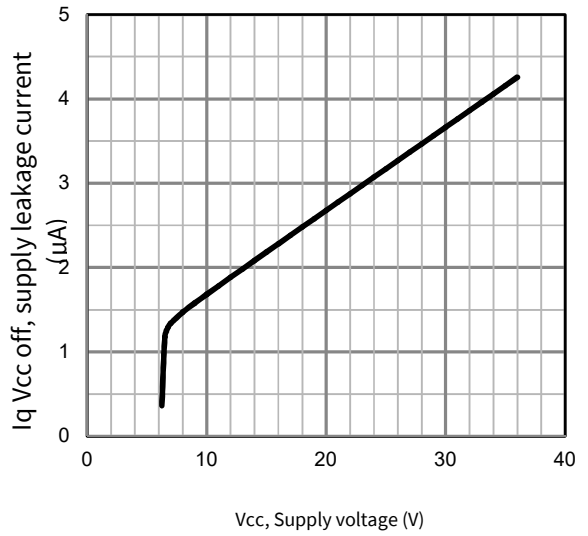

Figure 21 – Iq Vcc off (µA) Vs Vcc (V)

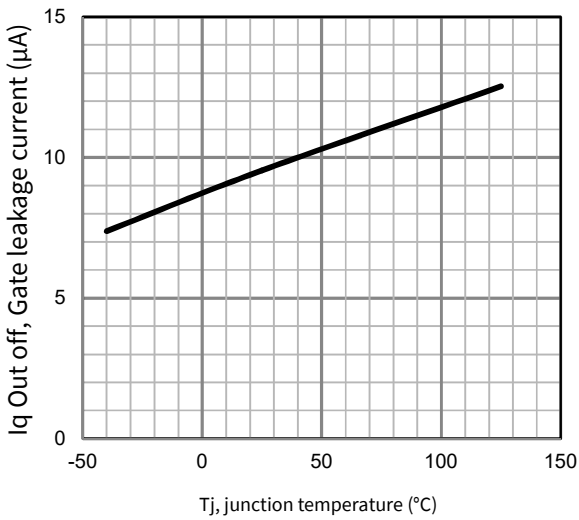

Figure 22 – Iq Out off (µA) Vs Tj (°C)

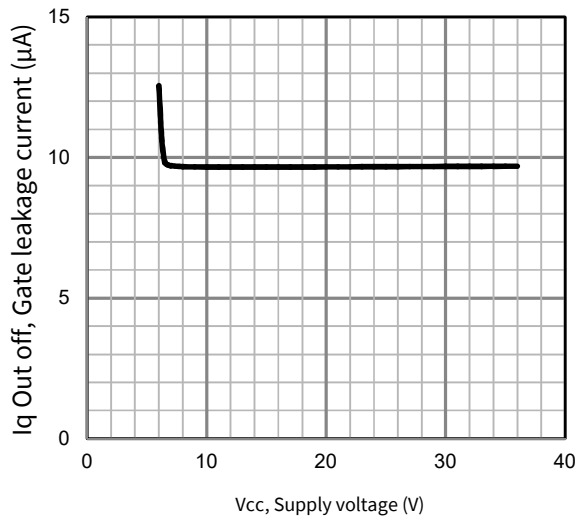
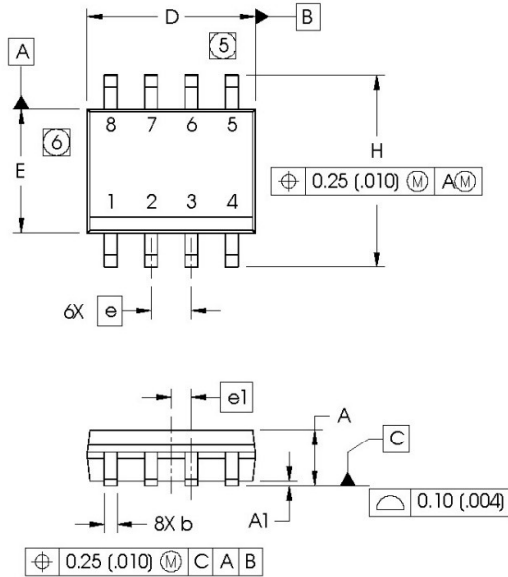

Figure 23 – Iq Out off (µA) Vs Vcc(V)

10 Case Outline – SO8

Dimensions are shown in millimeters (inches)



DIM	INCHES		MILLIMETERS	
	MIN	MAX	MIN	MAX
A	.0532	.0688	1.35	1.75
A1	.0040	.0098	0.10	0.25
b	.013	.020	0.33	0.51
c	.0075	.0098	0.19	0.25
D	.189	.1968	4.80	5.00
E	.1497	.1574	3.80	4.00
e	.050 BASIC		1.27 BASIC	
e1	.025 BASIC		0.635 BASIC	
H	.2284	.2440	5.80	6.20
K	.0099	.0196	0.25	0.50
L	.016	.050	0.40	1.27
y	0°	8°	0°	8°

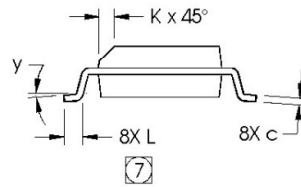

NOTES:

1. DIMENSIONING & TOLERANCING PER ASME Y14.5M-1994.
2. CONTROLLING DIMENSION: MILLIMETER
3. DIMENSIONS ARE SHOWN IN MILLIMETERS (INCHES).
4. OUTLINE CONFORMS TO JEDEC OUTLINE MS-012AA.
5. DIMENSION DOES NOT INCLUDE MOLD PROTRUSIONS. MOLD PROTRUSIONS NOT TO EXCEED 0.15 (.006).
6. DIMENSION DOES NOT INCLUDE MOLD PROTRUSIONS. MOLD PROTRUSIONS NOT TO EXCEED 0.25 (.010).
7. DIMENSION IS THE LENGTH OF LEAD FOR SOLDERING TO A SUBSTRATE.

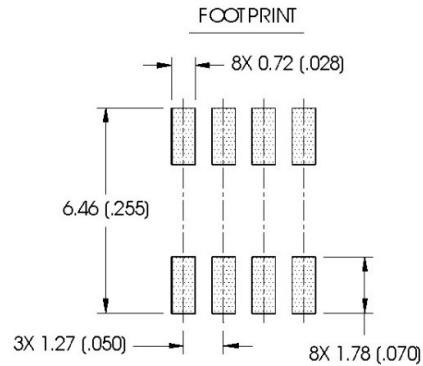

11 Tape & Reel SO8

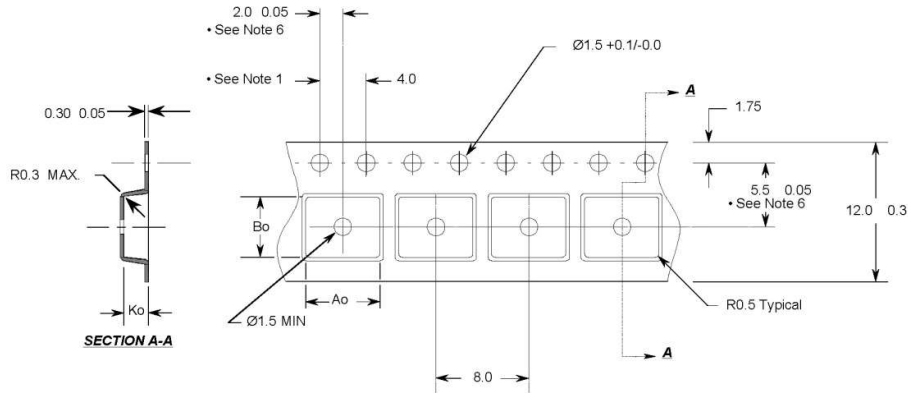

Notes:

1. 10 sprocket hole pitch cumulative tolerance 0.2
2. Camber not to exceed 1mm in 100mm
3. Material: Black Conductive Advantek Polystyrene
4. A_o and B_o measured on a plane 0.3mm above the bottom of the pocket
5. K_o measured from a plane on the inside bottom of the pocket to the top surface of the carrier.
6. Pocket position relative to sprocket hole measured as true position of pocket, not pocket hole.

$A_o = 6.4$ mm
 $B_o = 5.2$ mm
 $K_o = 2.1$ mm

- All Dimensions in Millimeters -

12 Part Marking Information

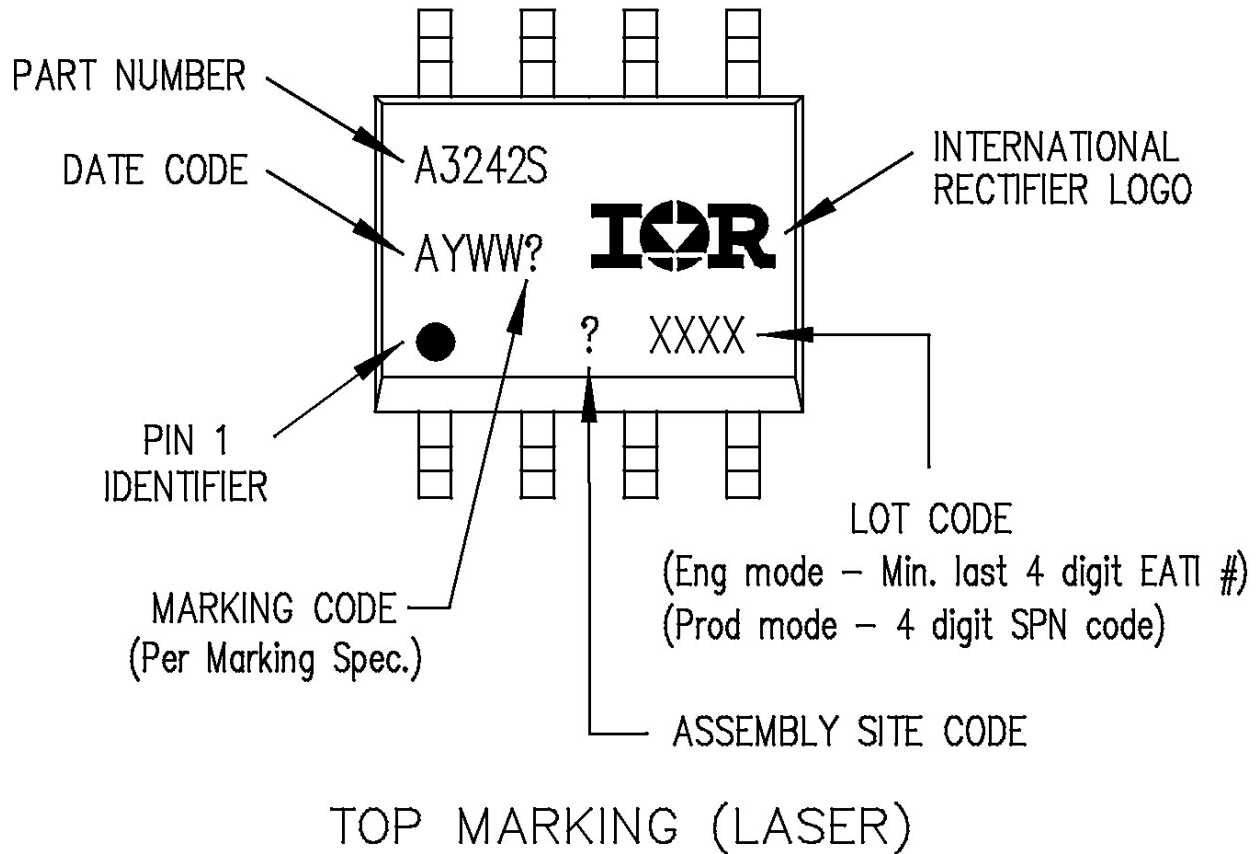

Qualification Information

Qualification Level		Automotive (per AEC-Q100)
		Comments: This family of ICs has passed an Automotive qualification. IR's Industrial and Consumer qualification level is granted by extension of the higher Automotive level.
Moisture Sensitivity Level		SOIC-8L MSL2, 260°C (per IPC/JEDEC J-STD-020)
SD	Human Body Model	Class 1C Passed 1500V (per AEC-Q100-002)
	Charged Device Model	Class C6 (+/-1000V) (per AEC-Q100-011)
IC Latch-Up Test		Class II Level A (per AEC-Q100-004)
RoHS Compliant		Yes

Published by
Infineon Technologies AG
81726 München, Germany
© Infineon Technologies AG 2015
All Rights Reserved.

IMPORTANT NOTICE

The information given in this document shall in no event be regarded as a guarantee of conditions or characteristics (“Beschaffenheitsgarantie”). With respect to any examples, hints or any typical values stated herein and/or any information regarding the application of the product, Infineon Technologies hereby disclaims any and all warranties and liabilities of any kind, including without limitation warranties of non-infringement of intellectual property rights of any third party.

In addition, any information given in this document is subject to customer’s compliance with its obligations stated in this document and any applicable legal requirements, norms and standards concerning customer’s products and any use of the product of Infineon Technologies in customer’s applications.

The data contained in this document is exclusively intended for technically trained staff. It is the responsibility of customer’s technical departments to evaluate the suitability of the product for the intended application and the completeness of the product information given in this document with respect to such application.

For further information on the product, technology, delivery terms and conditions and prices please contact your nearest Infineon Technologies office (www.infineon.com).

WARNINGS

Due to technical requirements products may contain dangerous substances. For information on the types in question please contact your nearest Infineon Technologies office.

Except as otherwise explicitly approved by Infineon Technologies in a written document signed by authorized representatives of Infineon Technologies, Infineon Technologies’ products may not be used in any applications where a failure of the product or any consequences of the use thereof can reasonably be expected to result in personal injury.

13 Revision history

Document version	Date of release	Description of changes
A1	June 8, 2016	First version
A2	January 3, 2017	Update Vbr Out and Vbr Gate page 5 Update maximum rating page 4
Rev 1.0	April 30 th 2018	Update to INFINEON template datasheet

Trademarks

All referenced product or service names and trademarks are the property of their respective owners.

Edition yyyy-mm-dd

Published by

Infineon Technologies AG

81726 München, Germany

© 2018 Infineon Technologies AG.

All Rights Reserved.

Do you have a question about this document?

Email: erratum@infineon.com

Document reference

IMPORTANT NOTICE

The information given in this document shall in no event be regarded as a guarantee of conditions or characteristics ("Beschaffheitsgarantie").

With respect to any examples, hints or any typical values stated herein and/or any information regarding the application of the product, Infineon Technologies hereby disclaims any and all warranties and liabilities of any kind, including without limitation warranties of non-infringement of intellectual property rights of any third party.

In addition, any information given in this document is subject to customer's compliance with its obligations stated in this document and any applicable legal requirements, norms and standards concerning customer's products and any use of the product of Infineon Technologies in customer's applications.

The data contained in this document is exclusively intended for technically trained staff. It is the responsibility of customer's technical departments to evaluate the suitability of the product for the intended application and the completeness of the product information given in this document with respect to such application.

For further information on the product, technology delivery terms and conditions and prices please contact your nearest Infineon Technologies office (www.infineon.com).

WARNINGS

Due to technical requirements products may contain dangerous substances. For information on the types in question please contact your nearest Infineon Technologies office.

Except as otherwise explicitly approved by Infineon Technologies in a written document signed by authorized representatives of Infineon Technologies, Infineon Technologies' products may not be used in any applications where a failure of the product or any consequences of the use thereof car reasonably be expected to result in personal injury.