

14V/19V High Efficiency Step-Up LED Driver with PWM Control

Features

- Up to 3 or 5 series LEDs
- Integrated 20V high current switch (1.2A limit)
- High efficiency PWM converter (up to 90%)
- Low 200mV feedback voltage
- High accuracy across full load range
- V_{IN} range 2.7V to 5.5V
- LED open-circuit (OVP) protection
 - KTD2511C: 19V
 - KTD2511D: 14V
- High switching frequency: 1MHz
- PWM dimming frequency: 100Hz to 200kHz
- Simple, small solution size
- Integrated Soft-start
- Shutdown Current less than 1 μ A
- Small TSOT23-6 and TDFN22-8 Package
- RoHS and Green compliant
- -40°C to +85°C Temperature Range

Brief Description

The KTD2511 is a versatile constant current LED driver with a high efficiency DC-DC step-up “boost” converter architecture. The low-side power MOSFET is integrated in the device, minimizing the total number of external components. High 1.2A current limit and 14V or 19V OVP allow the KTD2511D/C to drive numerous parallel strings of 3 or 5 LEDs in series, with KTD2511D or KTD2511C, respectively. KTD2511 can deliver 260mA total current with 3 series LEDs per string. It can also maximize the current capability while achieving high conversion efficiency. The optimized 1.0MHz switching frequency results in small external component size. The driver allows a wide range of PWM dimming frequencies through the EN pin.

Various protection features are built into the KTD2511, including cycle-by-cycle input current limit protection, LED open-circuit (output over voltage) protection and thermal shutdown protection. The leakage current in shutdown mode is less than 1 μ A.

The KTD2511 is available in a RoHS compliant 6-lead TSOT23 and 8-lead TDFN22 package.

Applications

- LED backlighting
- Mobile Phones
- Handheld Devices
- Digital Photo Frames
- Automotive Navigation

Typical Application

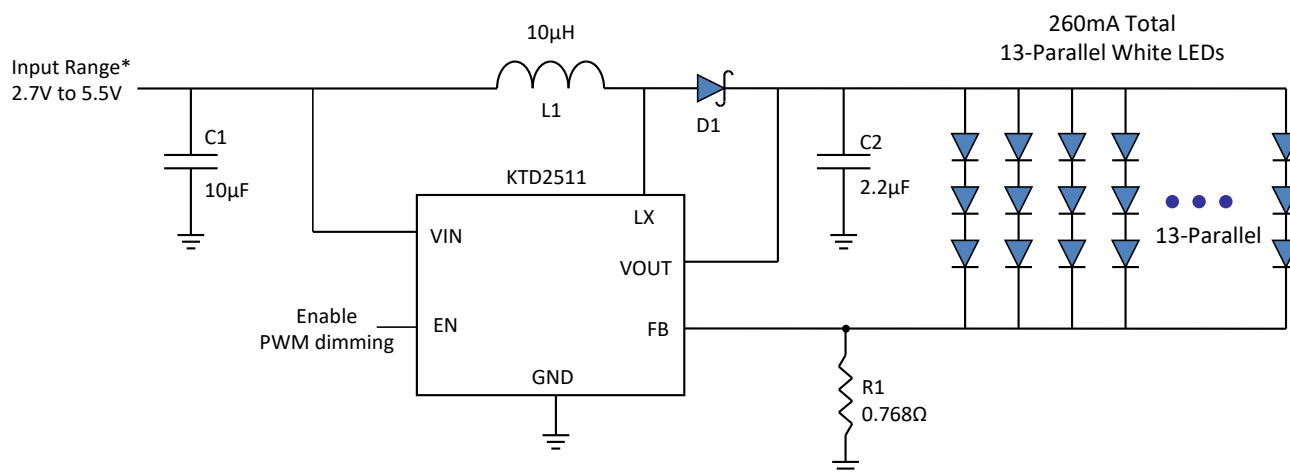

*Note: Maximum output current must be derated with V_{in} less than 3.4V

Pin Descriptions

TSOT23-6 and TDFN22-8

Pin #		Name	Function
TSOT23-6	TDFN22-8		
1	8	LX	Converter switching node
2	1, 5	GND	Converter/IC ground
3	6	FB	Output feedback pin regulated at 0.2V
4	4	EN	IC enable and PWM dimming control pin. A logic High signal enables converter. A PWM signal on this pin controls LED average conduction current.
5	3	VOUT	Output and over-voltage protection pin
6	2	VIN	IC supply voltage
--	7	NC	Not internally connected

TSOT23-6
Top View

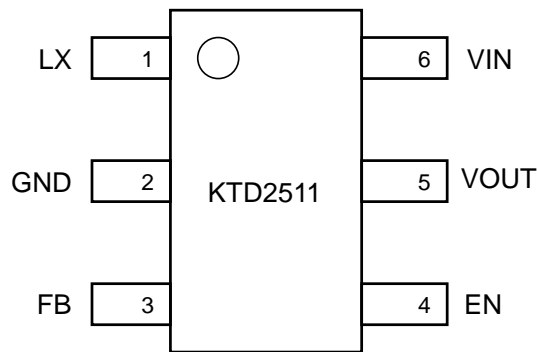

TDFN22-8
Top View

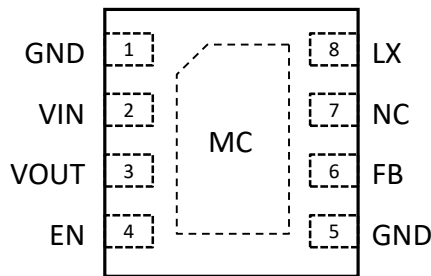

Absolute Maximum Ratings ⁽¹⁾

(T_A=25°C unless otherwise noted)

Symbol	Description	Value	Units
VIN	Input voltage	-0.3 to 6.0	V
VOUT	High voltage node	KTD2511D	-0.3 to 16
		KTD2511C	-0.3 to 21
LX	Switching node ⁽²⁾	KTD2511D	-1.2 to 16
		KTD2511C	-1.2 to 21
FB, EN	Other pins	-0.3 to VIN+0.3	V
T _J	Operating Temperature Range	-40 to 150	°C
T _s	Storage Temperature Range	-65 to 150	°C
T _{LEAD}	Maximum Soldering Temperature (at leads, 10 sec)	300	°C

- Stresses above those listed in Absolute Maximum Ratings may cause permanent damage to the device. Functional operation at conditions other than the operating conditions specified is not implied. Only one Absolute Maximum rating should be applied at any one time.
- LX Switching node can tolerate Absolute Maximum negative voltage rating with maximum 100mA flowing from GND to LX pin.

Thermal Capabilities

Symbol	Description	Value	Units
TSOT23-6			
θ _{JA}	Thermal Resistance – Junction to Ambient ³	190	°C/W
P _D	Maximum Power Dissipation at T _A ≤ 25°C	0.526	W
ΔP _D /°C	Derating Factor Above T _A = 25°C	-5.26	mW/°C
TDFN22-8			
θ _{JA}	Thermal Resistance – Junction to Ambient ³	65	°C/W
P _D	Maximum Power Dissipation at T _A ≤ 25°C	1.54	W
ΔP _D /°C	Derating Factor Above T _A = 25°C	-15.4	mW/°C

- Junction to Ambient thermal resistance is highly dependent on PCB layout. Values are based on thermal properties of the device when soldered to an EV board.

Ordering Information

Part Number	OVP Threshold (nominal)	Marking	Operating Temperature	Package
KTD2511CEHD-TR	19V	GCYYZ ⁴	-40°C to +85°C	TSOT23-6
KTD2511CECE-TR	19V	GCYYZ ⁴	-40°C to +85°C	TDFN22-8
KTD2511DEHD-TR	14V	FPYYZ ⁴	-40°C to +85°C	TSOT23-6
KTD2511DECE-TR	14V	FPYYZ ⁴	-40°C to +85°C	TDFN22-8

- “YYZ” is the date code and assembly code.

Electrical Characteristics ⁽⁵⁾

Unless otherwise noted, the *Min* and *Max* specs are applied over the full operation temperature range of -40°C to $+85^{\circ}\text{C}$, while *Typ* values are specified at room temperature (25°C). $V_{\text{IN}} = 3.6\text{V}$.

Symbol	Description	Conditions	Min	Typ	Max	Units
IC Supply						
V_{IN}	Input operating range		2.7		5.5	V
UVLO	Input under voltage lockout	Rising edge		2.5	2.65	V
UVLO _{HYST}	UVLO hysteresis			0.15		V
I_{Q}	IC quiescent current (non switching)	FB=0.4V		0.28	0.5	mA
	IC operating current (switching)	FB=0V		0.7	1.65	mA
I_{SHDN}	V_{IN} pin shutdown current	EN=GND		0.1	1.0	μA
Step-Up Converter						
V_{FB}	FB pin voltage accuracy		0.184	0.2	0.216	V
I_{FB}	FB pin bias current				0.1	μA
$R_{\text{DS(ON)}}$	NMOS on-resistance	$T_{\text{A}} = 25^{\circ}\text{C}$		0.3		Ω
I_{LX}	LX pin leakage current			0.1		μA
I_{LIM}	Peak NMOS current limit			1.2		A
F_{SW}	Oscillator frequency			1.0		MHz
D_{max}	Maximum duty cycle		92	95		%
OVP	Over voltage threshold	Measured at VOUT pin	KTD2511C	19		V
			KTD2511D	14		
T_{S}	Start-up time			2000		μs
Control						
$V_{\text{TH-L}}$	Logic low threshold				0.4	V
$V_{\text{TH-H}}$	Logic high threshold		1.4			V
T_{OFF}	EN low to shutdown time			3		ms
F_{EN}	Dimming frequency		0.1		200	kHz
$D_{\text{PWM_MIN}}$	PWM dimming duty cycle resolution	$f_{\text{DIM}} = 5\text{kHz}$	1			%
		$f_{\text{DIM}} = 30\text{kHz}$	1			
$T_{\text{J-TH}}$	IC junction thermal shutdown threshold			150		$^{\circ}\text{C}$
	IC junction thermal shutdown hysteresis			15		$^{\circ}\text{C}$

5. The KTD2511 is guaranteed to meet performance specifications over the -40°C to $+85^{\circ}\text{C}$ operating temperature range by design, characterization and correlation with statistical process controls.

Typical Characteristics

$V_{IN} = 3.6V$, $L = 10\mu H$ (Coilcraft LPS4018-103ML), $C_{IN} = 10\mu F$, $C_{OUT} = 2.2\mu F$, $R1 = 1\Omega$ with 3S10P LEDs at 20mA (200mA total output current), $T_{AMB} = 25^\circ C$ unless otherwise specified.

Efficiency vs. Input Voltage

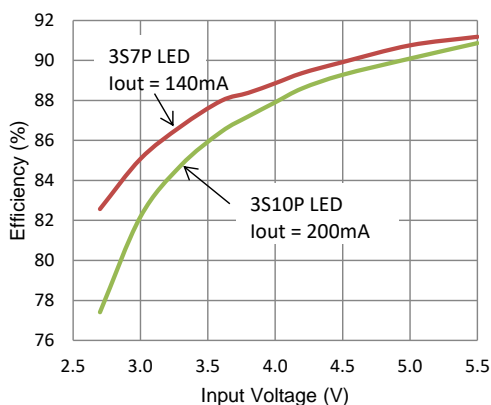

Efficiency vs. LED Current (20kHz PWM dimming)

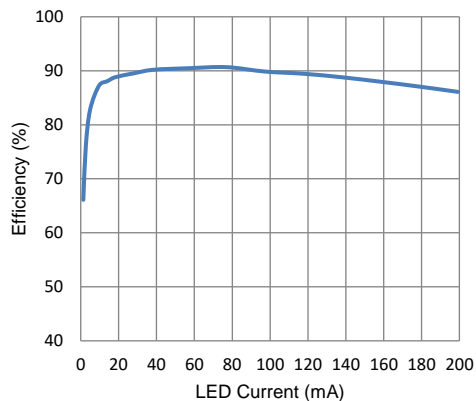

Operating Current (non-switching)

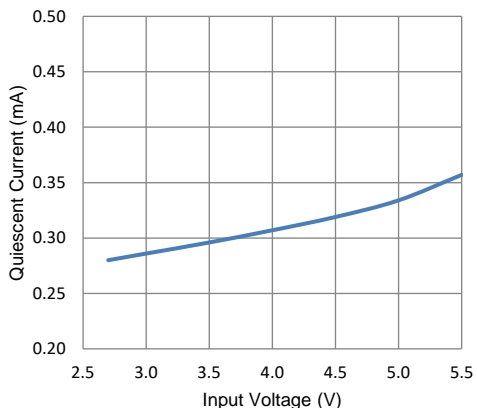

Operating Current (switching)

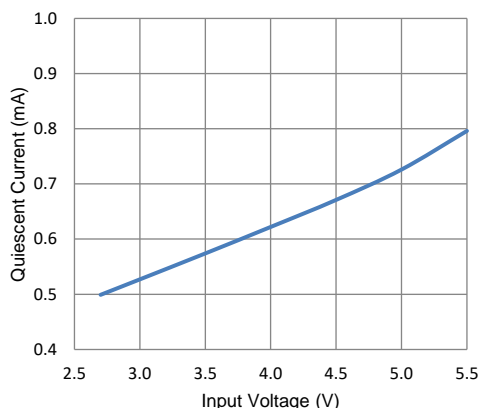

Switching Frequency

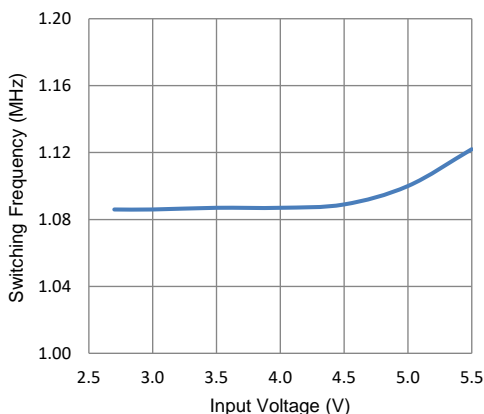

EN Logic Threshold Voltage

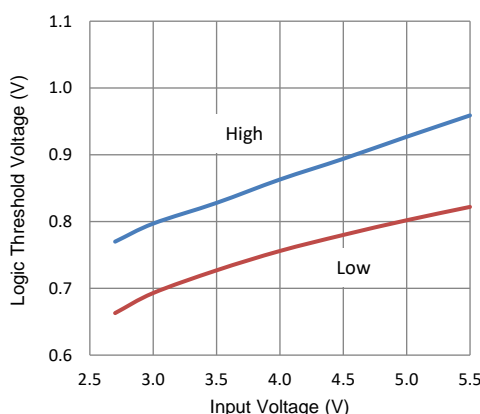

Typical Characteristics (continued)

$V_{IN} = 3.6V$, $L = 10\mu H$ (Coilcraft LPS4018-103ML), $C_{IN} = 10\mu F$, $C_{OUT} = 2.2\mu F$, $R_1 = 1\Omega$ with 3S10P LEDs at 20mA (200mA total output current), $T_{AMB} = 25^\circ C$ unless otherwise specified.

Soft Start Turn On

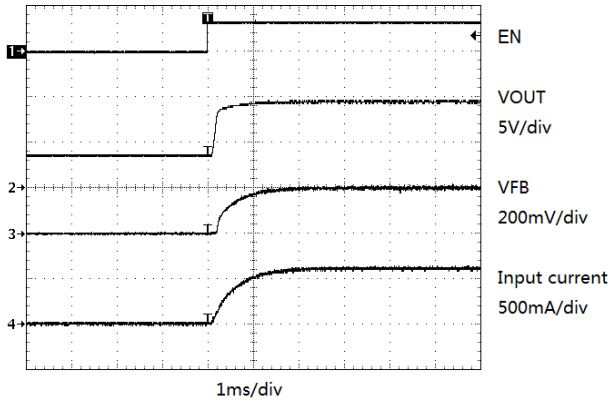

Turn Off

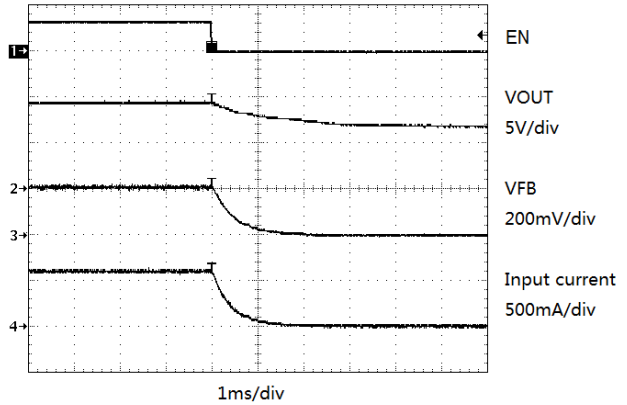

Steady State Switching

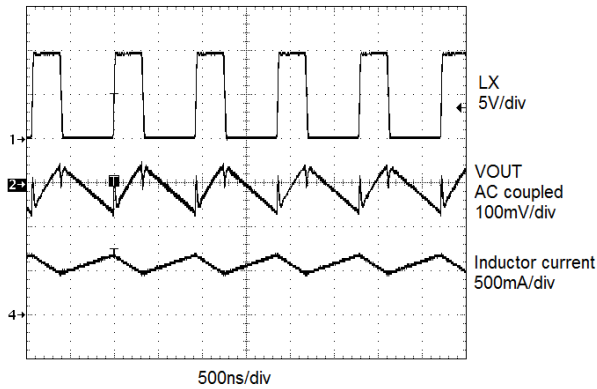

Turn On with LED Open (OVP)

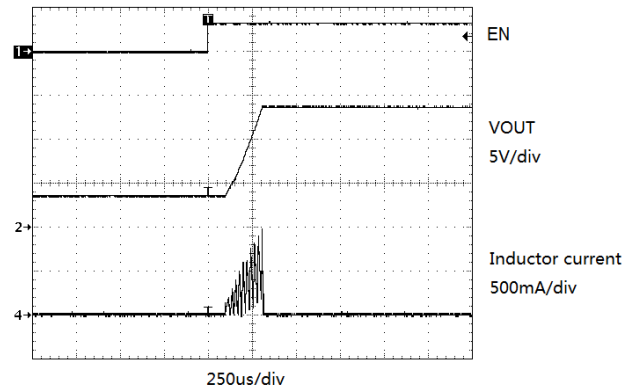

PWM Dimming (20kHz)

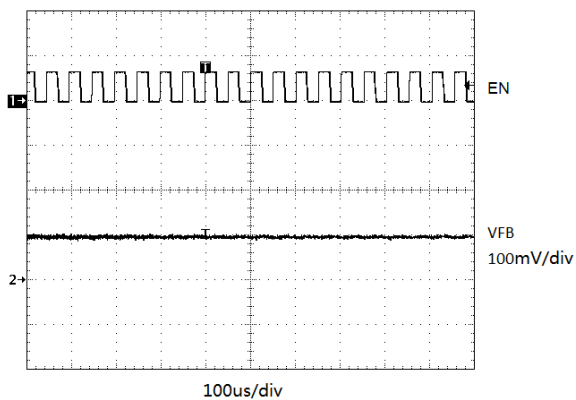

PWM Dimming Linearity (20kHz)

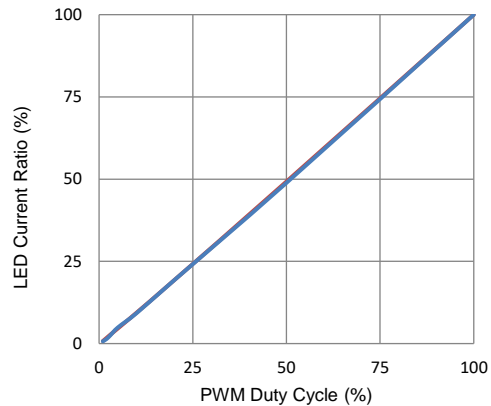

Functional Block Diagram

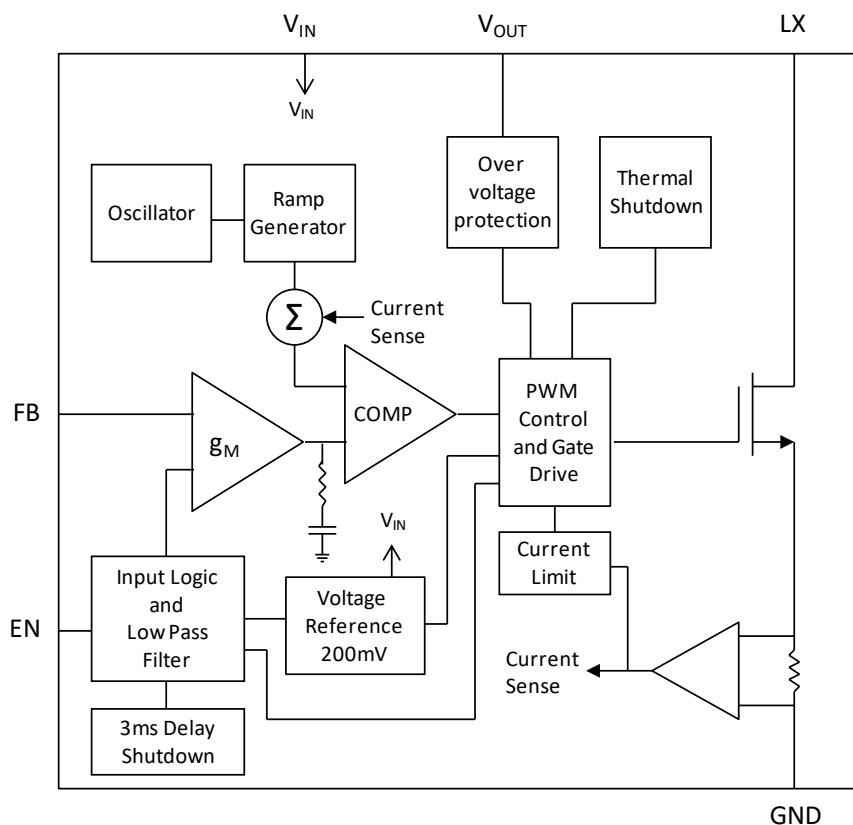

Functional Description

The KTD2511 uses a constant-frequency current-mode boost converter architecture to control the LED current by regulating the feedback voltage. Please refer to the functional block diagram above for an explanation of KTD2511 operation. The beginning of each cycle turns on the Power MOSFET. A slope compensation ramp is added to the output of the current sense amplifier and the result is fed into the positive input of the comparator (COMP). When this voltage goes above the output voltage of the error amplifier (g_M), the Power MOSFET is turned off. The voltage at the output of the g_M block amplifies the difference between the reference voltage and the feedback voltage (V_{FB}), so that FB pin voltage can be regulated to the reference voltage.

The KTD2511 has built-in soft-start to limit the inrush current during startup and to limit the amount of overshoot on the output. Protection features in the KTD2511 include over-voltage protection (OVP), cycle-by-cycle current limit protection and thermal shutdown. OVP protects in the event where an LED fails open, which forces the feedback voltage to zero. This causes the boost converter to operate in maximum duty cycle mode, ramping up the output voltage. Switching will stop when the output reaches the OVP threshold. The OVP feature protects the IC from damaging itself by exceeding the voltage rating on LX/VOUT pins.

Application Information

Inductor Selection

A 10 μ H to 22 μ H inductor is recommended for 3-Series LED applications. If high efficiency is a critical requirement, a low DCR inductor should be selected. The inductor's saturation current rating should also exceed the peak input current, especially for high load current application (like 3S13P).

Table 1. Recommended Inductor Part Numbers

Inductor Part Number	Value (μ H)	DCR (Ω)	Saturation Current (A)	Dimensions (mm)	Manufacturer
LPS4018-103ML	10	0.20 max	1.3	4 x 4 x 1.8	Coilcraft
VLF4014AT-100MR90	10	0.26	0.9	3.5 x 3.7 x 1.4	TDK
VLCF5020T-100MR87	10	0.182 max	0.87	5 x 5 x 2.0	TDK
LQH55DN220M03L	22	0.19	1.2	5.7 x 5.0 x 4.7	Murata

Capacitor Selection

Small size ceramic capacitors are ideal for KTD2511 applications. A 10 μ F input capacitor and a 0.47 μ F output capacitor are suggested for 3-Series LED applications. For higher output current applications like 3S10P to 3S13P, larger value output capacitors like 2.2 μ F are recommended to minimize output ripple.

Table 2. Recommended Ceramic Capacitor Vendors

Manufacturer	Website
Murata	www.murata.com
AVX	www.avx.com
Taiyo Yuden	www.t-yuden.com

Diode Selection

Using a schottky diode is recommended in KTD2511 applications because of its low forward voltage drop and fast reverse recovery time. The current rating of the schottky diode should exceed the peak current of the boost converter. The voltage rating should also exceed the target output voltage.

Table 3. Recommended Schottky Diode Part Numbers

Schottky Diode Part Number	Forward Voltage (V)	Forward Current (mA)	Reverse Voltage (V)	Manufacturer
B130	0.52	1000	30	Vishay

Typical Application Circuit

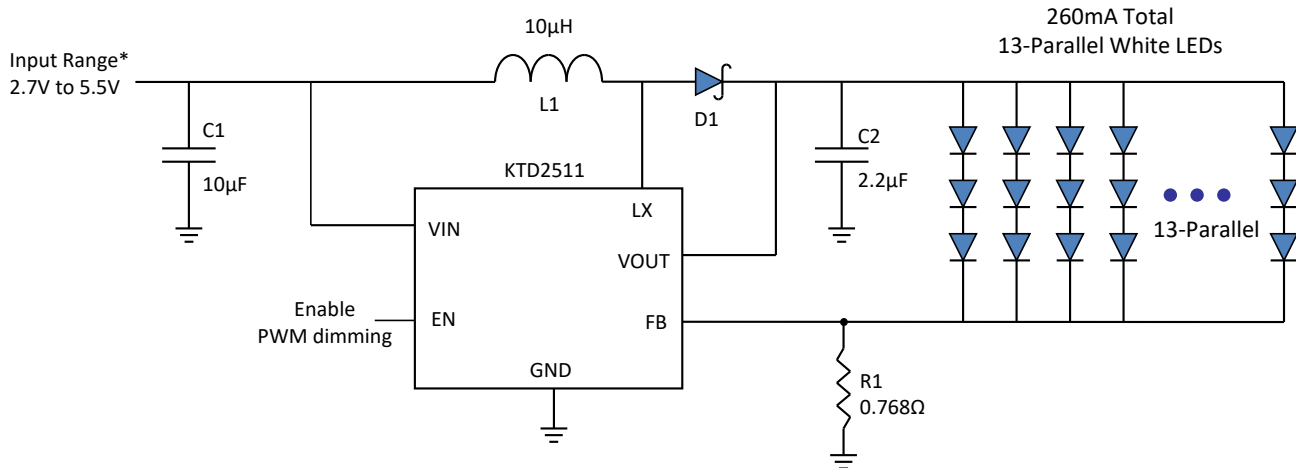

*Note: Maximum output current must be derated with V_{in} less than 3.4V

Figure 1. Application Circuit for 39 LEDs at 260mA Total Current (3-Series, 13-Parallel)

LED Current Setting

The LED current is determined by the feedback resistor R1. The feedback voltage (V_{FB}) is internally set at 200mV. The LED current is programmed according to the formula $I_{LED} = V_{FB} / R1 = 200mV / R1$. For accurate LED current settings, precision 1% resistors are recommended. The formula and table for R1 selection are shown below.

$$R1 = 200mV / I_{LED}$$

Table 4. Current Setting Resistor (1% Values)

R1 (Ω) 1% Values	LED Current (mA)
200	1
40.2	5
20.0	10
13.3	15
10.0	20
6.65	30
2.00	100
1.33	150
1.00	200
0.909	220
0.825	240
0.768	260

LED Dimming Control

Below there are four different LED dimming control methods described:

1. Using a PWM Signal to EN Pin

With the PWM signal applied to the EN pin, the KTD2511 is correspondingly turned ON or OFF by the PWM signal. The LEDs alternate between zero and full programmed current. The average LED current increases proportionally with the duty cycle of the PWM signal. A 0% duty cycle PWM signal will turn off the KTD2511 and corresponds to zero LED current. A 100% duty cycle PWM signal turns on the LEDs continuously at full current. The typical frequency range of the PWM signal is 100Hz to 200kHz. The magnitude of the PWM signal should be higher than the minimum EN voltage HIGH specification. The KTD2511 has an internal RC filter which creates a DC average of the PWM duty cycle. The -3dB cutoff frequency of the low pass filter is 360Hz. PWM control signals with low frequencies will not be filtered which means a PWM ripple can pass to the output; however, the average output current is continuously proportional to the PWM control signal regardless of the ripple amplitude. For systems which are sensitive to audible noise, it is recommended to use PWM frequencies greater than 5kHz.

2. Using a DC Voltage

For some applications, the preferred method of brightness control is a variable DC voltage to adjust the LED current. The dimming control using a DC voltage is shown in Figure 2. As the DC voltage increases, the voltage drop on R2 increases and the voltage drop on R1 decreases. Thus, the LED current decreases. The selection of R2 and R3 should make the current from the variable DC source much smaller than the LED current and much larger than the FB pin leakage current. The formula for LED current is

$$I_{LED} = \left(1 + \frac{R2}{R3}\right) \times \frac{V_{FB}}{R1} - \frac{R2}{R3} \times \frac{V_{DC}}{R1}$$

Figure 2. Dimming Control using a DC voltage

3. Using a Filtered PWM Signal

The filtered PWM signal can be considered as an adjustable DC voltage. It can be used to replace the variable DC voltage source in dimming control. The circuit is shown in Figure 3. This method can be used for higher frequency PWM signals compared to method #1 above. The magnitude of the PWM signal will affect the final result. The formula for LED current is

$$I_{LED} = \left(1 + \frac{R2}{R3 + R4}\right) \times \frac{V_{FB}}{R1} - \frac{R2}{R3 + R4} \times \frac{A_{PWM} \cdot D_{PWM}}{R1},$$

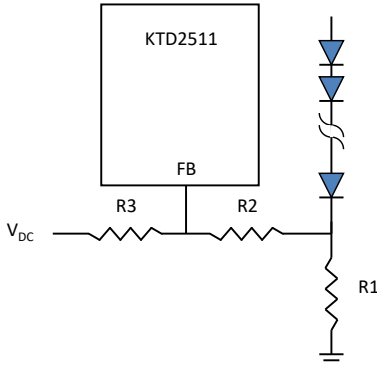
where A_{PWM} is the magnitude of the PWM signal, and D_{PWM} is the duty cycle of the PWM signal. This method doesn't have a PWM frequency upper limit, but the minimum PWM duty cycle requirement must be considered from system standpoint when the PWM frequency is high. The lower limit of the PWM frequency is controlled by the RC filter, PWM frequency should be higher than the cutoff frequency of the RC filter.

The following example in Figure 3 shows the LED current dimming range from 0mA to 22mA. The PWM frequency range can vary from 200Hz to 100kHz. In this example, the PWM signal voltage is 0V to 2.5V, 0% duty cycle results in maximum LED current of 22mA, and 95% duty cycle or more results in 0mA LED current. Figure 4 shows the PWM dimming linearity test result with 1kHz PWM frequency. Figure 5 shows the LED current across a range of PWM frequency.

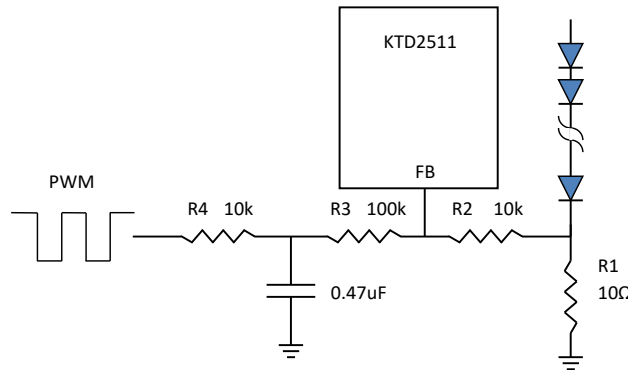

Figure 3. Dimming Control using an RC Filtered PWM Signal

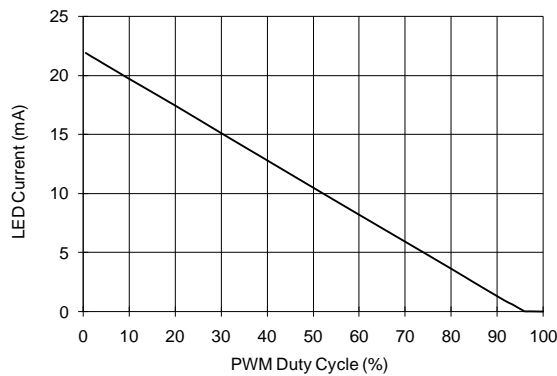

Figure 4. RC Filtered PWM Dimming Linearity (1kHz)

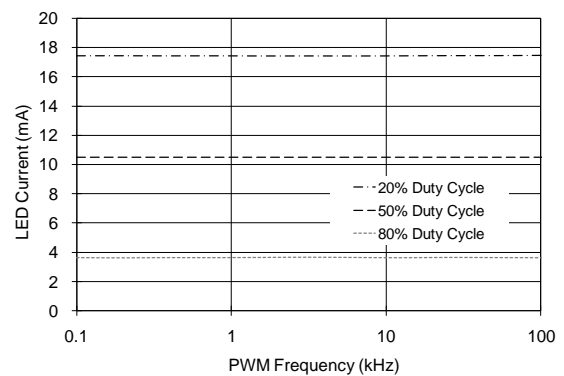

Figure 5. LED Current vs RC Filtered PWM Frequency

4. Using a Logic Signal

For applications that need to adjust the LED current in discrete steps, a logic signal can be used as shown in Figure 6. R1 sets the minimum LED current (when the NMOS is off). R3 sets how much the LED current increases when the NMOS is turned on. The $R_{DS(ON)}$ of the NMOS should be much smaller than R3 in this method.

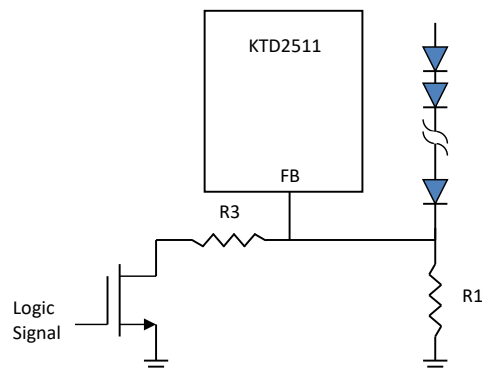

Figure 6. Dimming Control using a Logic Signal

Layout Considerations

PCB layout is very important for high frequency switching regulators in order to keep the loop stable and minimize noise. The input capacitor should be very close to the IC to get the best decoupling. For the best performance, an input RC ($R = 20\Omega$, $C = 4.7\mu\text{F}$) filter is recommended connected to the IC's VIN pin to prevent any interference between the boost converter input and the IC input. The path of the inductor, schottky diode and output capacitor should be kept as short as possible to minimize noise and ringing. FB is a sensitive node and it should be kept separate from the LX switching node in the PCB layout. Please see the KTD2511 evaluation document for detailed PCB layout guidelines.

Packaging Information

TSOT23-6

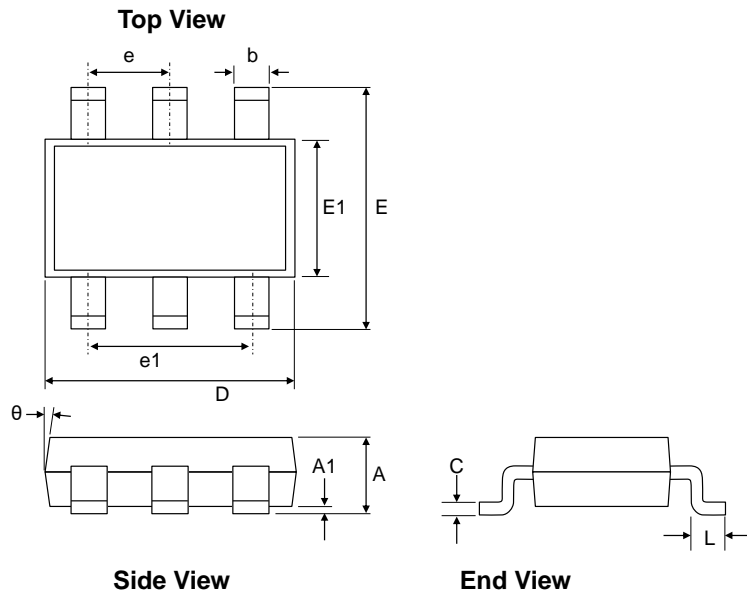

Dimension	mm		
	Min.	Typ.	Max.
A	0.60	0.85	1.10
A1	0.00	0.05	0.10
b	0.30	0.40	0.50
c	0.10	0.15	0.20
D	2.70	2.90	3.10
E	2.60	2.80	3.00
E1	1.40	1.60	1.80
e	0.95BSC		
e1	1.9BSC		
L	0.30		0.60
θ	4°		12°

TSOT23-6 Recommended Footprint

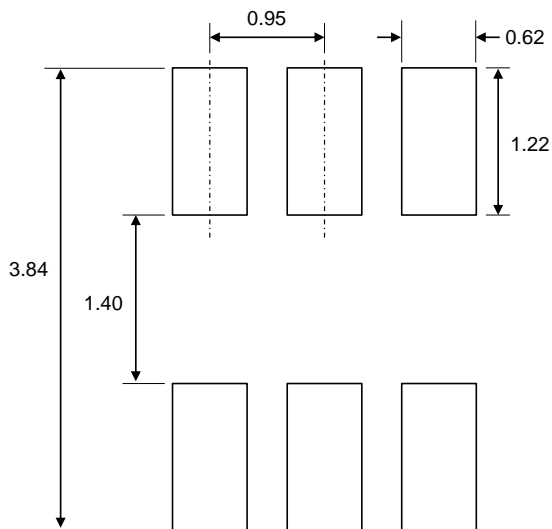

* Dimensions are in millimeters.

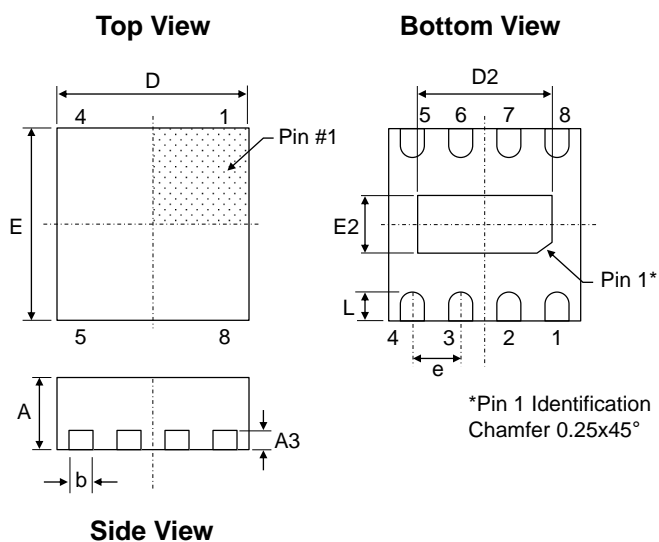

Dimension	mm		
	Min.	Typ.	Max.
A	0.70	0.75	0.80
A3	0.203 BSC		
b	0.20	0.25	0.30
D	1.95	2.00	2.05
D2	1.35	1.40	1.45
E	1.95	2.00	2.05
E2	0.55	0.60	0.65
e	0.50 BSC		
L	0.25	0.30	0.35

TDFN22-8 Recommended Footprint

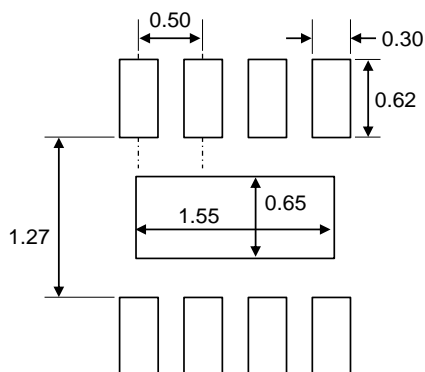

* Dimensions are in millimeters.

Kinetic Technologies cannot assume responsibility for use of any circuitry other than circuitry entirely embodied in a Kinetic Technologies product. No intellectual property or circuit patent licenses are implied. Kinetic Technologies reserves the right to change the circuitry and specifications without notice at any time.