

THIS DRAWING IS UNPUBLISHED. RELEASED FOR PUBLICATION
 © COPYRIGHT - By - ALL RIGHTS RESERVED.

REVISIONS				
P	LTR	DESCRIPTION	DATE	APVD
B		UPDATE PER ECO-16-002588	24 FEB 16	CAS CAS

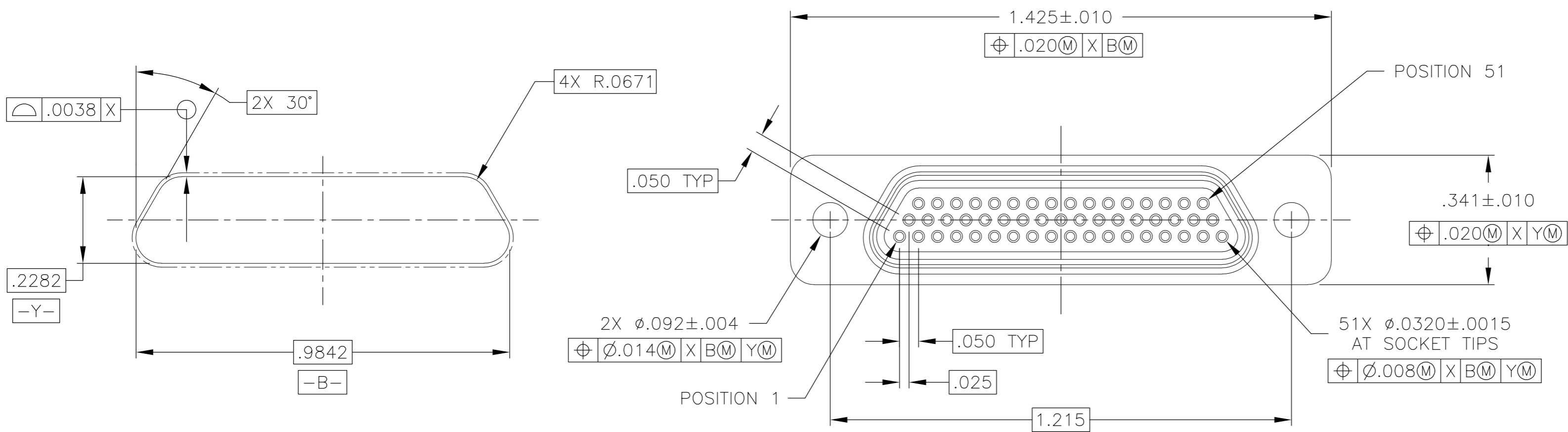

INTERFACE DETAIL

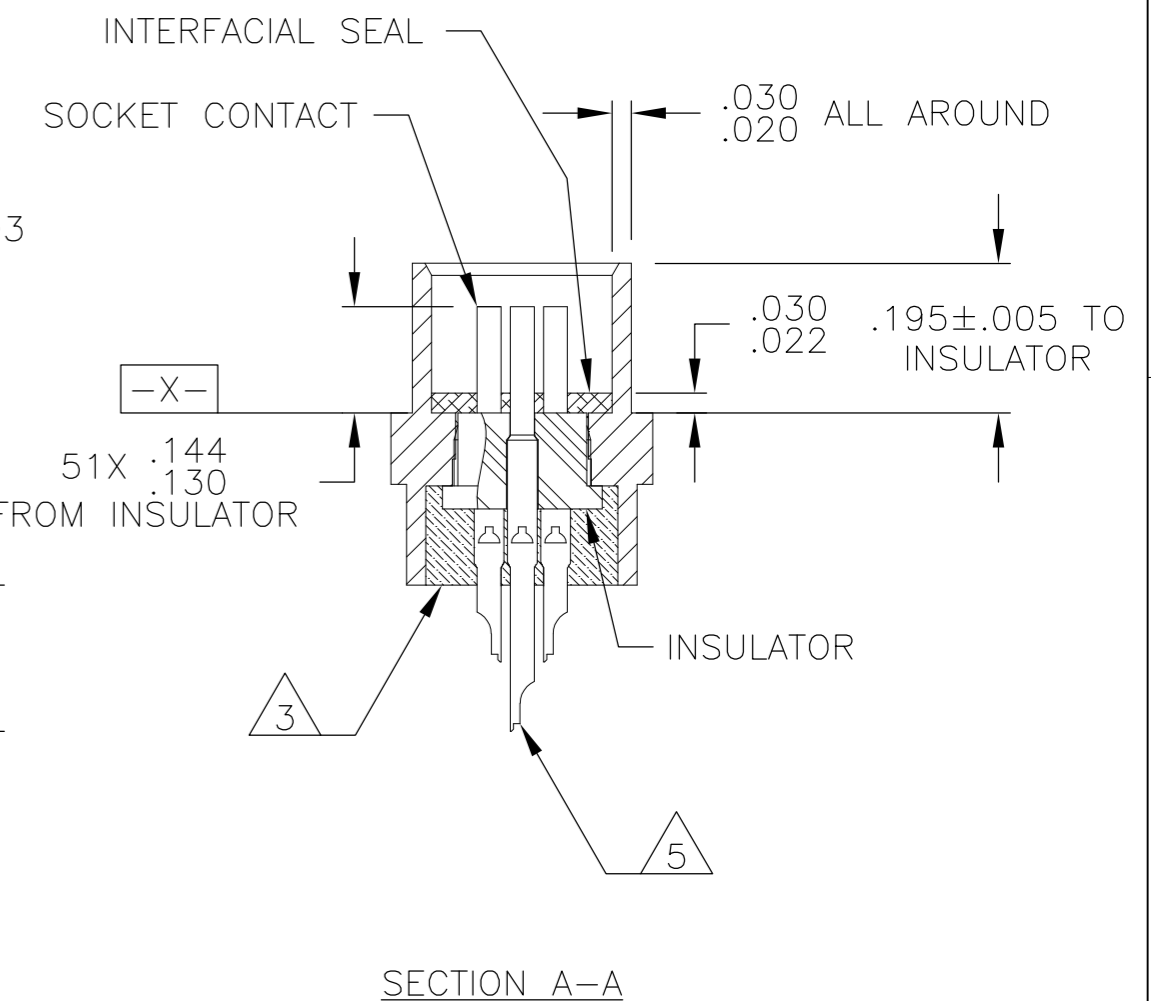
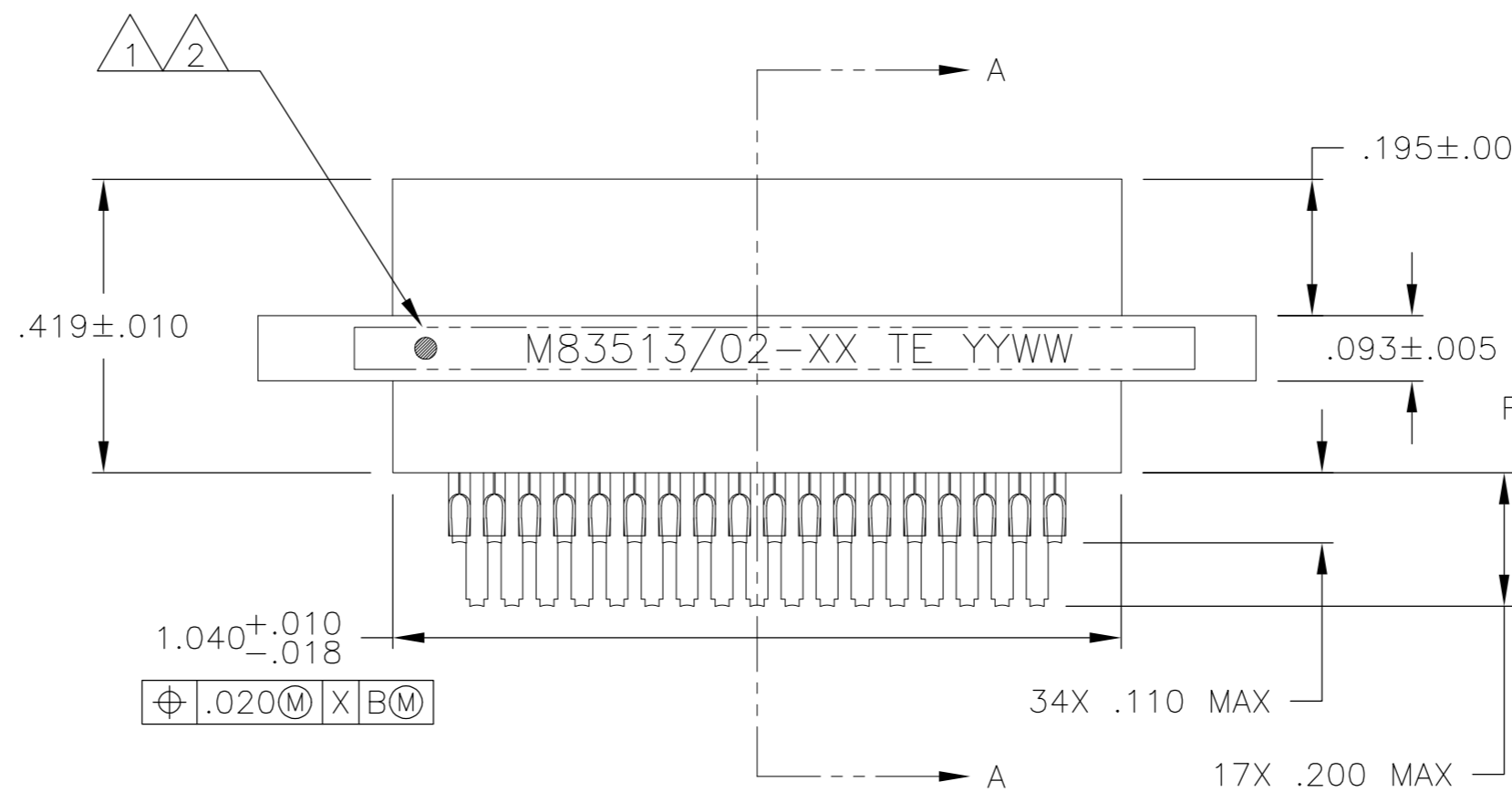
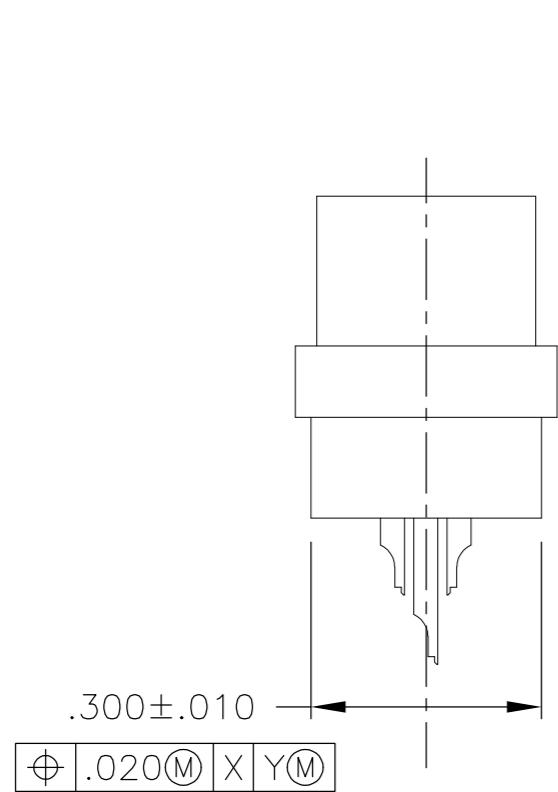

SECTION A-A

- 1 CONNECTOR SHALL BE MARKED IN ACCORDANCE WITH METHOD 1 OF MIL-STD-1285. MARKING SHALL CONTAIN THE MILITARY PIN, CAGE CODE (OR TE), AND DATE CODE. EXAMPLE: M83513/02-XX TE YYWW (WHERE XX IS PART OF THE PIN SHOWN IN THE "MIL-DTL-83513" COLUMN OF THE PART NUMBER TABLE, AND YYWW IS THE DATE CODE). TEXT HEIGHT SHALL BE .035 INCH MINIMUM.
- 2 POSITION 1 SHALL BE INDICATED BY AN IDENTIFIABLE MARK, LOCATED APPROXIMATELY AS SHOWN ON THE POSITION 1 SIDE OF THE CONNECTOR FLANGE. THIS MARK SHALL BE INCLUDED AS PART OF THE PART MARKING INFORMATION.
- 3 EPOXY ENCAPSULATION. EPOXY MAY WICK .050 INCH MAX FOR SOLDER CUPS.
- 4 ALL DIMENSIONS AND REQUIREMENTS ARE PER MIL-DTL-83513/2
- 5 CHAMFER ON SOLDER POTS ARE PARALLEL WITH THE SIDE OF CONNECTOR WITHIN 10°

THIS DRAWING IS A CONTROLLED DOCUMENT.		DWN B. ROMANCHUK 03 SEP 08		
DIMENSIONS: INCHES		CHK M. STORRY 03 SEP 08		
TOLERANCES UNLESS OTHERWISE SPECIFIED:		APVD M. STORRY 03 SEP 08	NAME RECEPTACLE ASSEMBLY, MICRO-D PER MIL-DTL-83513/02, MCKS SERIES, 51 POSITION	
0 PLC ± -		PRODUCT SPEC	SIZE A2	
1 PLC ± -		APPLICATION SPEC	CAGE CODE 98278	
2 PLC ± .010			DRAWING NO 1532207	
3 PLC ± .005			RESTRICTED TO	
4 PLC ± -			-	
ANGLES ± 1°		WEIGHT	-	
MATERIAL SEE NOTES		FINISH	-	
		CUSTOMER DRAWING	SCALE 4:1 SHEET 1 of 2 REV B	

