

LED Drivers for LCD Backlights

White LED Driver for large LCD Panels (DCDC Converter type)

BD93942F

General Description

BD93942F is a high efficiency driver for white LEDs and designed for large LCDs. These ICs are built-in a boost DCDC converters that employ an array of LEDs as the light source. BD93942F have some protect function against fault conditions, such as the over-voltage protection (OVP), the over current limit protection of DCDC (OCP), the short circuit protection (SCP), the open detection of LED string. Therefore BD93942F are available for the fail-safe design over a wide range output voltage.

Key Specification

- Operating power supply voltage range: 9.0V to 35.0V
- LED minimum current 30mA
- LED maximum current: 150mA
- Oscillator frequency: 150kHz (RT=100kΩ)
- Operating Current: 3.7mA (Typ.)
- Operating temperature range: -40°C to +85°C

Applications

TV, Computer Display, Notebook, LCD Backlighting

Package

SOP16

W(Typ.) x D(Typ.) x H(Max.)
10.00mm x 6.20mm x 1.71mm

Features

- 4ch LED constant current driver and DC/DC converter
- Maximum LED Current: 150mA
- LED Feedback Voltage: 0.45V (@ILED=150mA) so lower heat. Adjustable Feed Back Voltage by following LED Current setting.
- ±2% LED current accuracy (ADIM=2.5V, when each LED is set to 100mA)
- Analog current (Linear) dimming at ADIM pin
- LED pin rating 60V
- Individual detection and individual LED OFF for both open and short circuits
- Built-in ISET pin short-circuit protection circuit
- FET's Gate (N pin) is driven by 5.8V swing
- Built-in Vout discharge circuit for shutdown
- Built-in Vout overvoltage protection (OVP) / reduced voltage protection (SCP) circuit
- SOP16 package

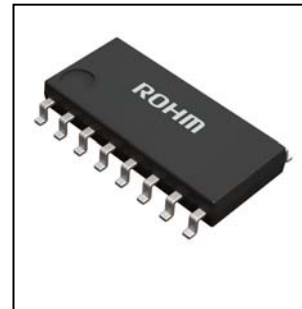

Figure 1. SOP16

Typical Application Circuit

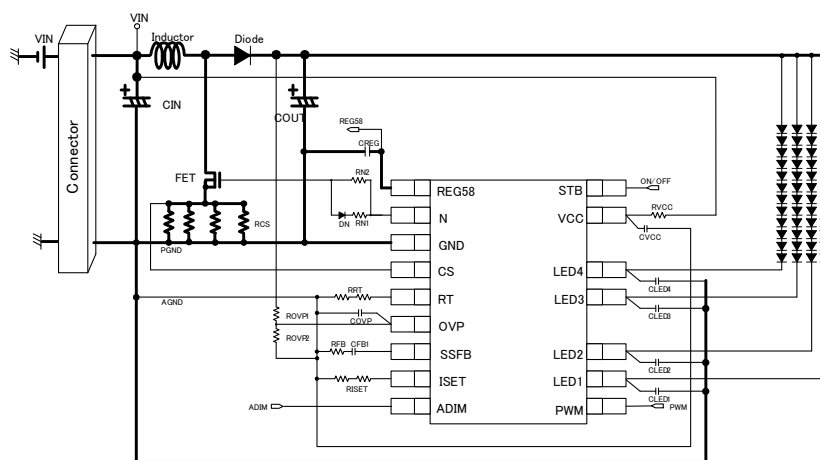

Figure 2. Typical Application Circuit

Absolute maximum ratings (Ta=25°C)

Parameter	Symbol	Ratings	Unit
Power supply voltage	VCC	36	V
STB, ADIM, OVP, PWM terminal voltage	STB, ADIM, OVP, PWM	36	V
LED1 to 4 terminal voltage	LED1 to 4	60	V
REG58, CS, N, ISET, SSFB, RT terminal voltage	REG58, CS, N, ISET, SSFB, RT	7	V
Power dissipation (SOP16)	Pd	0.62 *1	W
Operating temperature range	Topr	-40 to +85	°C
Storage temperature range	Tstg	-55 to +150	°C
Junction temperature	Tjmax	150	°C

*1 Ta = 25°C or more, diminished at -5mW/°C in the case of SOP16 (when 1-layer / 70.0 mm x 70.0 mm x 1.6 mm board is mounted)

Operating Ratings

Parameter	Symbol	Limits	Unit
VCC supply voltage	VCC	9.0 to 35.0	V
Min. output current of LED1 to 4	ILED_MIN	30	mA *1
Max. output current of LED1 to 4	ILED_MAX	150	mA *1,2
ADIM input voltage1 (use ADIM function)	VADIM1	0.2 to 2.7 (normal op.) 1.0 to 2.7 (start up)	V *3
ADIM input voltage1 (don't use ADIM function)	VADIM2	REG58 to 35.0	V
DC/DC oscillation frequency	Fsw	100 to 800	kHz
Min. on-duty time for PWM light modulation	PWM_MIN	30	µs

*1 The amount of current per channel.

*2 If LED makes significant variations in its reference voltage, the driver will increase power dissipation, resulting in a rise in package temperature.

To avoid this problem, design the board with thorough consideration given to heat radiation measures.

*3 To avoid unused LED pin's misdetection, set ADIM within 1.0V to 2.7V at start up stage. After unused LED pin's detection, set ADIM within 0.2V to 2.7V in normal operation.

Pin Configuration

SOP16

Figure 3. Pin Configuration

Marking diagram and physical dimension

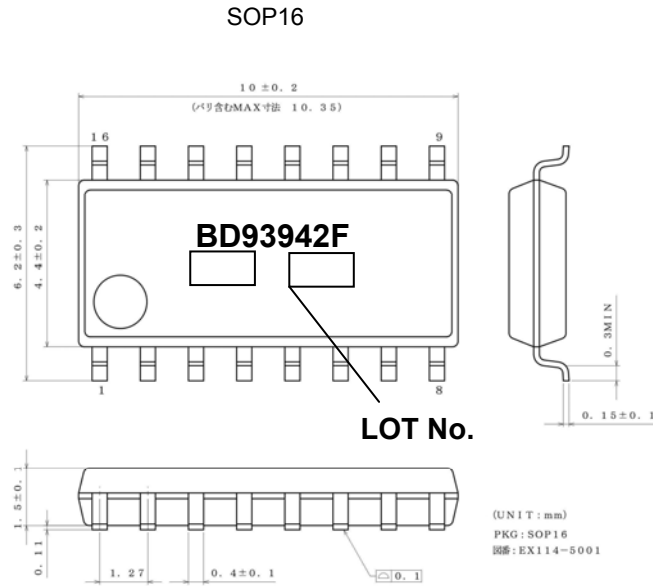

Figure 4. Physical Dimension

Electrical Characteristics (Unless otherwise noted, $T_a = 25^\circ\text{C}$, $V_{CC}=24\text{V}$)

Parameter	Symbol	Limit			Unit	Condition
		Min.	Typ.	Max.		
[Whole Device]						
Circuit current while in operation	ICC	-	3.7	7.4	mA	STB=3V,PWM=3V, RT=100k Ω
Circuit current while in standby	ISTB	-	40	80	μA	STB=0V
[REG58 Block]						
REG58 Output Voltage	REG58	5.742	5.8	5.858	V	IO=0mA
REG58 available current	I _{REG58}	15	-	-	mA	
[UVLO Block]						
UVLO release voltage	VUVLO_VCC	6.5	7.5	8.5	V	VCC=SWEEP UP
UVLO hysteresis voltage	VUHYS_VCC	150	300	600	mV	VCC=SWEEP DOWN
[DC/DC Block]						
Error amp. Reference voltage	VLED	0.425	0.450	0.475	V	ISET=50k Ω , ADIM=2.5V ILED=150mA
Oscillation frequency	fsw	142.5	150.0	157.5	kHz	RT=100k Ω
Max. duty cycle per output of N pin	D _{MAX}	83	90	97	%	RT=100k Ω
On resistance on N pin source side	RONH	-	4	8	Ω	I _{ON} =-10mA
On resistance on N pin sink side	RONL	-	3	6	Ω	I _{ON} =10mA
SSFB pin source current (at soft start)	ISSSO	-13.0	-10.0	-7.0	μA	SSFB=2V
SSFB sink current	IFBSI	50	100	150	μA	LED=2.0V,SSFB=1.0V
SSFB source current	IFBSO	-150	-100	-50	μA	LED=0V, SSFB=1.0V
Over current detection voltage	VCS	0.40	0.45	0.50	V	CS=SWEEP UP

Electrical Characteristics (Unless otherwise noted, Ta = 25°C, VCC=24V)

Parameter	Symbol	Limit			Unit	Condition
		Min.	Typ.	Max.		
[DC/DC Protection Block]						
Overvoltage protection detection voltage	VOVP	2.7	3.0	3.3	V	OVP=SWEEP UP
Overvoltage protection detection hysteresis voltage	VOVP_HYS	50	100	200	mV	OVP=SWEEP DOWN
Short circuit protection detection voltage	VSCP	0.04	0.10	0.25	V	OVP=SWEEP DOWN
[LED Driver Block]						
LED pin current accuracy 1	dILED1	-2	-	2	%	I _{LED} =100mA, (ADIM=2.5V,ISET=75kΩ)
LED pin current accuracy 2	dILED2	-3.2	-	3.2	%	I _{LED} =70mA, (ADIM=1.75V,ISET=75kΩ)
LED pin current accuracy 3	dILED3	-4.6	-	4.6	%	I _{LED} =50mA, (ADIM=1.25V,ISET=75kΩ)
LED pin current accuracy 4	dILED4	-8	-	8	%	I _{LED} =30mA, (ADIM=0.75V,ISET=75kΩ)
LED pin current accuracy 5	dILED5	-3	-	3	%	I _{LED} =100mA, (ADIM=7V,ISET=75kΩ)
LED pin Leakage Current	ILLED	-2.5	-	2.5	μA	LED=60V
LED open detection voltage	VOPEN	0.05	0.2	0.285	V	LED=SWEEP DOWN
LED short detection voltage	VSHORT	4	5	6	V	LED=SWEEP UP
ADIM pin Input Current	ILADIM	-2.5	-	2.5	μA	ADIM=3V
[STB Block]						
STB pin high-level voltage	STBH	2	-	35	V	STB=SWEEP UP
STB pin low-level voltage	STBL	-0.3	-	0.8	V	STB=SWEEP DOWN
STB pin pull-down resistance	RSTB	500	1000	1500	kΩ	STB=3.0V
[PWM Block]						
PWM pin high-level voltage	PWMH	2	-	35	V	PWM=SWEEP UP
PWM pin low-level voltage	PWML	-0.3	-	0.8	V	PWM= SWEEP DOWN
PWM pin pull-down resistance	RPWM	180	300	420	kΩ	PWM=3.0V
[Failure Indication Block (Open Drain)]						
AUTO Timer	tAUTO	-	0.655	-	sec	RT=75kΩ
Abnormal Detection Timer	tCP		20		ms	RT=75kΩ

Pin Descriptions (SOP16)

Pin No	Pin Name	In/Out	Function	Rating [V]
1	REG58	Out	Power supply for N pin	-0.3 to 7
2	CS	In	DC/DC output current detection and OCP detection pin	-0.3 to 7
3	N	Out	DC/DC switching output pin	-0.3 to 7
4	GND	-	Ground pin	-
5	OVP	In	Overvoltage protection detection pin	-0.3 to 36
6	STB	In	Enable pin	-0.3 to 36
7	LED1	Out	Output pin 1 for LED	-0.3 to 60
8	LED2	Out	Output pin 2 for LED	-0.3 to 60
9	LED3	Out	Output pin 3 for LED	-0.3 to 60
10	LED4	Out	Output pin 4 for LED	-0.3 to 60
11	PWM	In	External PWM light modulation signal input pin for LED1-4	-0.3 to 36
12	ISET	Out	LED current setting resistor connection pin	-0.3 to 7
13	SSFB	In/Out	Soft start setting, Loop compensation setting pin	-0.3 to 7
14	RT	Out	DC/DC drive frequency setting resistor connection pin.	-0.3 to 7
15	ADIM	In	Analog dimming DC voltage input pin	-0.3 to 36
16	VCC	In	Power supply pin	-0.3 to 36

Pin ESD Type

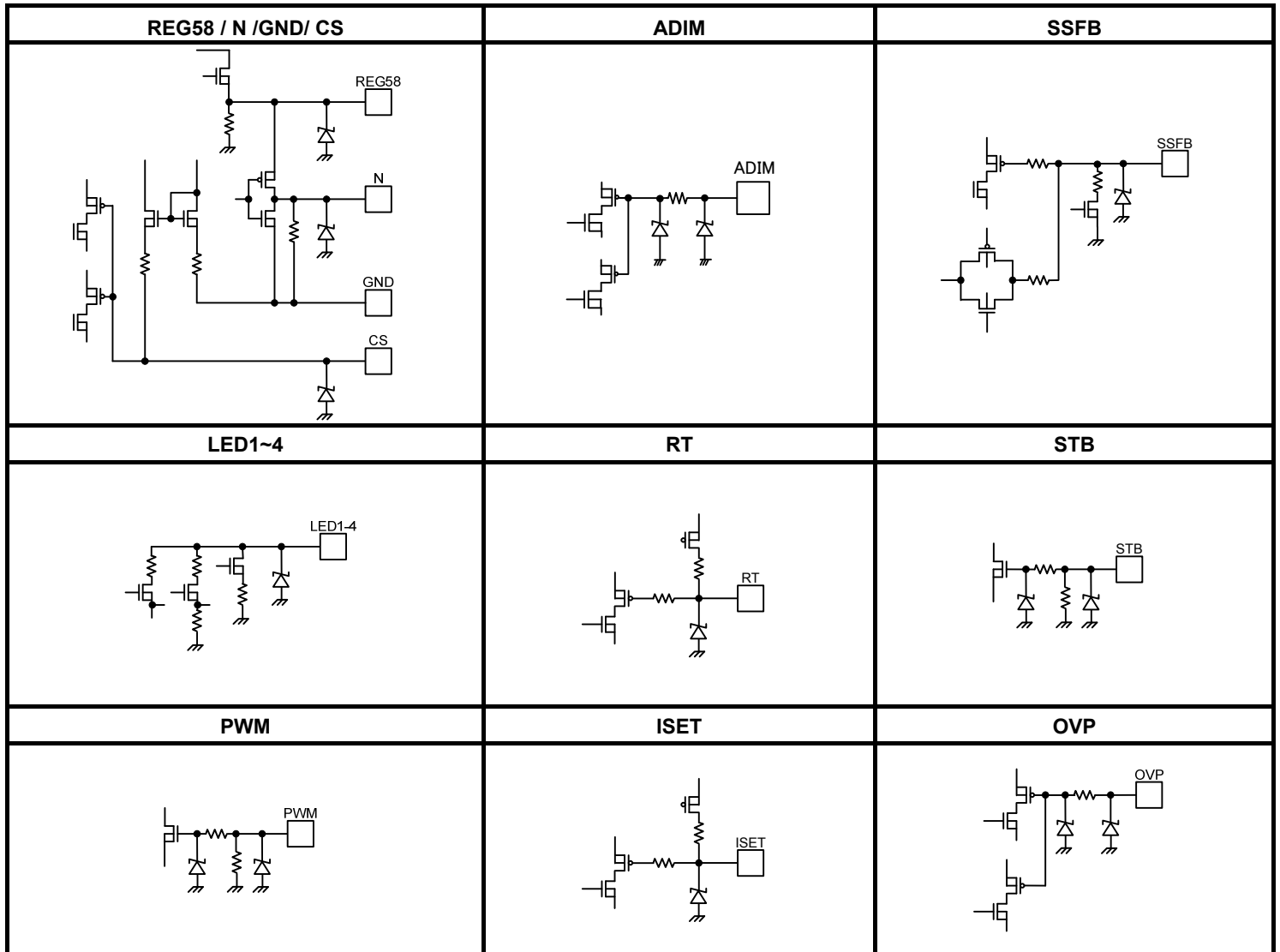

Figure 5. Pin ESD Type

Block Diagram

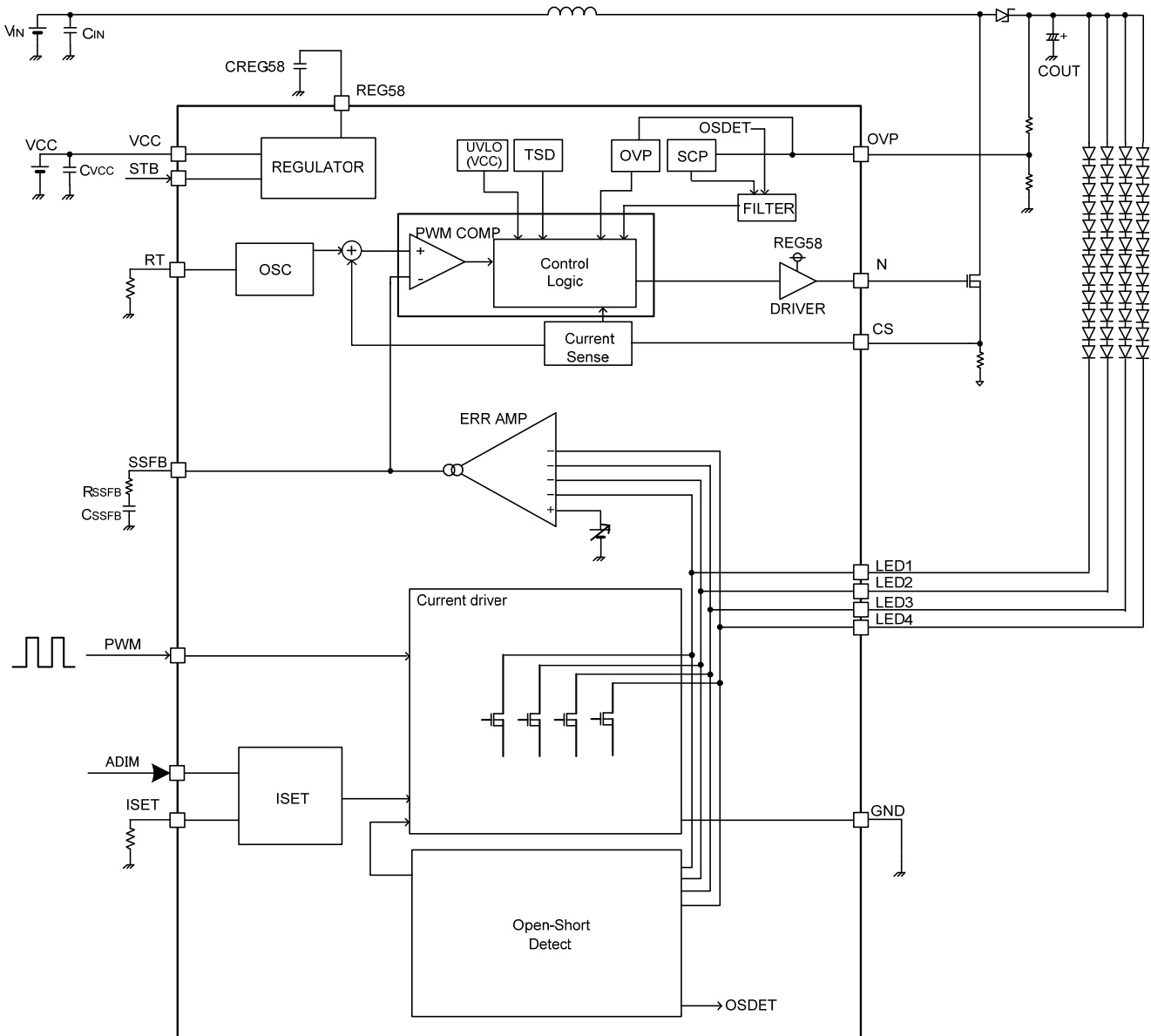

Figure 6. Block Diagram

Typical Performance Curve

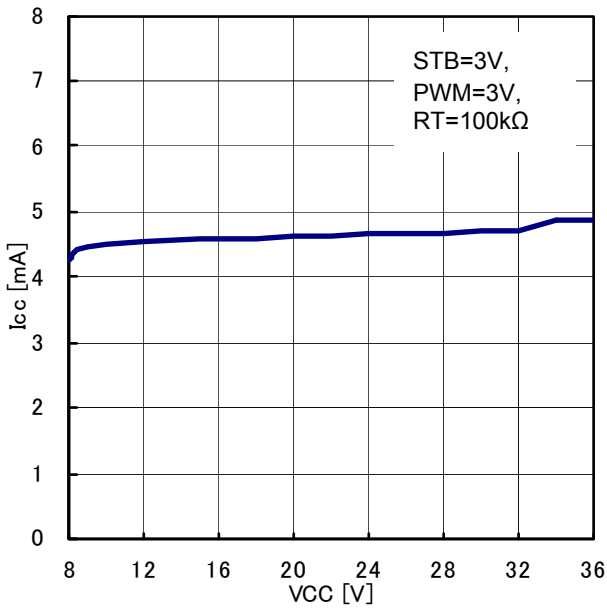

Figure 7. Operating Current (ICC) [mA] vs. VCC[V]

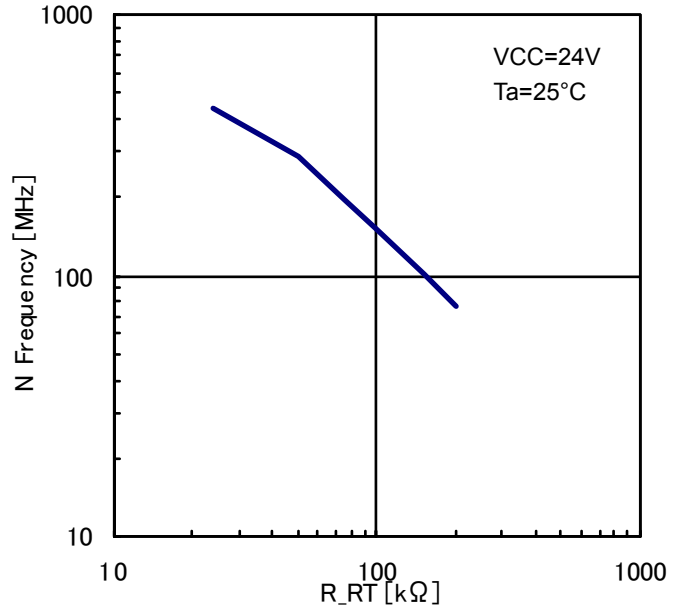

Figure 8. N Frequency [MHz] vs. R_RT [kΩ]

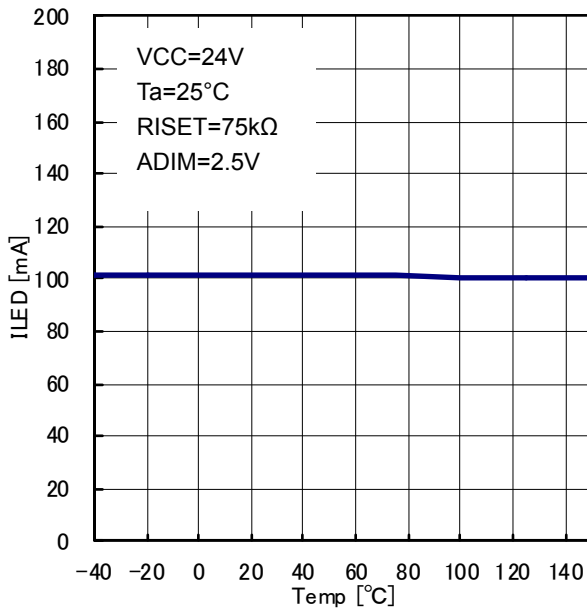

Figure 9. LED Current (ILED) [mA] vs. Temp [°C]

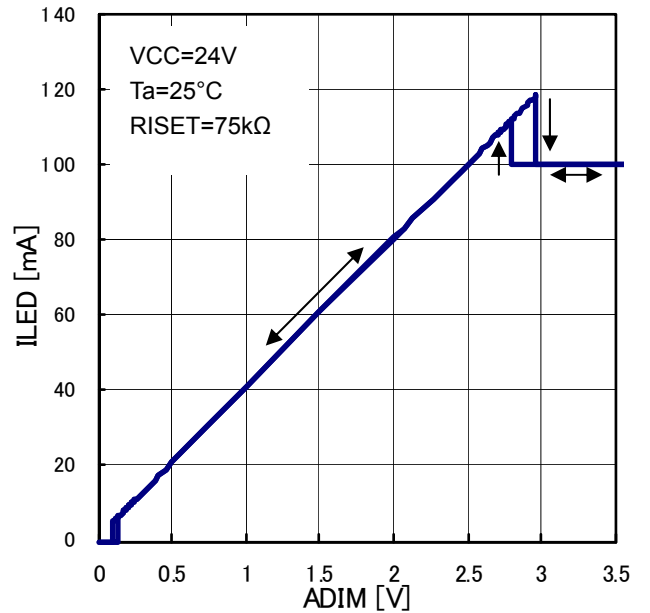

Figure 10. LED Current (ILED) [mA] vs. ADIM[V],

Pin Function

○ REG58 (1pin)

The REG58 pin is used in the DC/DC converter driver block to output 5.8V power. The maximum operating current is 15mA. Using the REG58 pin at a current higher than 15mA can affect the N pin output pulse, causing the IC to malfunction and leading to heat generation of the IC itself. To avoid this problem, it is recommended to make load setting to the minimum level.

Please place the ceramic capacitor connected to REG58 pin (2.2μF to 10μF) closest to REG58-GND pin.

○ CS (2pin)

The CS pin has the following two functions:

1. DC/DC current mode current feedback function

Current flowing through the inductor is converted into voltage by the current sensing resistor RCS connected to the CS pin and this voltage is compared with voltage set with the error amplifier to control the DC/DC output voltage.

2. Inductor current limit function

The CS pin also incorporates the over current protection (OCP) function. If the CS pin voltage reaches 0.45V (Typ.) or more, switching operation will be forcedly stopped.

○ N (3pin)

The N pin is used to output power to the external NMOS gate driver for the DC/DC converter in the amplitude range of approx. 0 to REG58. ON resistances is 4.0Ω(typ.) in source (H side), 3.0Ω(typ.) in sink (L side).

Frequency setting can be made with a resistor connected to the RT pin. For details of frequency setting, refer to the description of the RT pin.

○ GND (4pin)

Ground of the IC.

○ OVP (5pin)

The OVP pin is an input pin for over-voltage protection and short circuit protection of DC/DC output voltage. If over-voltage is detected, the OVP pin will stop the DC/DC converter conducting step-up operation. When the short circuit protection (SCP) function is activated, the DC/DC converter will stop operation, and then the timer will start counting. When the timer completes counting the preset period of time, the LED drivers are stopped.

The OVP pin is of the high impedance type and involves no pull-down resistor, resulting in unstable potential in the open-circuited state. To avoid this problem, be sure to make input voltage setting with the use of a resistive divider or otherwise.

○ STB (6pin)

The STB pin is used to make setting of turning ON and OFF the IC and allowed for use to reset the IC from shutdown.

Note: The IC state is switched (i.e., the IC is switched between ON and OFF state) according to voltages input in the STB pin. Avoid using the STB pin between two states (0.8 to 2.0V).

When STB signal is set to Low or High, change it from Low to High after REG58 output completely discharges.

○ LED1 – LED4 (7pin – 10pin)

The LED1 to 4 pins are used to output constant current to LED drivers. Current value setting can be made by connecting a resistor to the ISET pin.

For the current value setting procedure, refer to the description of "ISET pin".

If any of the LED pins is put in an erroneous state (e.g. short circuit mode, open circuit mode, or ground short circuit mode), the relevant protection function will be activated.

This IC is detected automatically that it is an unused channel by assuming the LED terminal to be connected to GND before start up.

○ PWM (11pin)

The PWM pin is used to turn ON and OFF LED drivers. Light can be modulated by changing the duty cycle through the direct input of a PWM light modulation signal. The high and low voltage levels of PWM pin is as listed in the table below:

State	PWM Voltage
LED ON state	PWM= 2.0V to 35V
LED OFF state	PWM= -0.3V to 0.8V

○ ISET (12pin)

The ISET pin is an output current setting resistor. Output current I_{LED} varies in inverse proportion to resistance. The relation between output current I_{LED} and the resistance of ISET pin connection resistor R_{ISET} is given by the following equation:

$$I_{LED} [mA] = \frac{3000}{R_{ISET} [k\Omega]} \times V_{ADIM} [V] \quad (\text{ADIM}=0.2V \text{ to } 2.7V)$$

$$I_{LED} [mA] = \frac{7500}{R_{ISET} [k\Omega]} \quad (\text{ADIM}>4V \text{ to } 35V)$$

Output current setting should be made in the range of 30mA to 150mA.

It prepares automatically to suitable LED feedback voltage that can output LED current set by ISET pin. In short LED feedback voltage is dropped when the LED current is small and the IC heating is held automatically. In case of a large current is needed, raise the LED pin feedback voltage. And it adjusts automatically to LED pin voltage that can be flow large LED current.

The calculation is as below.

$$V_{LED} = 3 \times I_{LED} [A] [V] \quad (I_{LED} > 117mA)$$

$$V_{LED} = 0.35[V](typ) \quad (I_{LED} < 117mA)$$

The LED feedback voltage (V_{LED}) is clamped to 0.35V (typ.) when the LED current (I_{LED}) is less than 117mA.

ADIM input range is from 0V to 35V. And the range which the LED currents change with linearity is from 0.2V to 2.7V. When it reaches under V_{ISET}×0.90V(typ.), the LED current is off to prevent from passing a large current to the LED pin when the R_{ISET} is shorted and the ISET pin is shorted to the GND. And as the ISET pin returns to a normal state, the LED current returns.

○ SSFB (13pin)

The SSFB pin is used to make setting of soft start time and duty for soft start, and DC/DC current mode control error amplifier. It performs constant current charge of 10uA to the external capacitor connected to SSFB terminal, which enables soft-start of DC/DC converter.

The SSFB pin detects the voltages of LED pins (1 to 4) and controls inductor current so that the pin voltage of the LED located in the row with the highest V_f will come to 0.45V(ADIM=2.5V,ISET=50kΩ,ILED=150mA). As a result, the pin voltages of other LEDs become higher by V_f variation. After completion of soft start, the SSFB pin is put into the high-impedance state with the PWM signal being in the low state, thus maintaining the SSFB voltage.

Since the LED protection function (OPEN/SHORT detection) works when it turns to the LED feedback mode.

○ RT (14pin)

The RT pin is used to connect a DC/DC frequency setting resistor. DC/DC drive frequency is determined by connecting the RT resistor.

ODrive frequency vs. RT resistance (Ideal)

$$R_{RT} = \frac{15000}{f_{SW} [kHz]} [k\Omega]$$

When RT is 100kΩ, F_{sw} is 150kHz(typ.). However, drive frequency setting should be made in the range of 100 kHz to 800 kHz.

○ ADIM (15pin)

ADIM pin is for analog dimming. Output current is proportionality with input voltage. Basically, ADIM pin assumes the voltage inputted externally using high accuracy of resistive divider and etc., IC internally is in OPEN (High impedance) condition. Cannot use in an OPEN condition.

If you don't use analog dimming, please connect pull-up resistor to over 5V (for example REG58).

○ VCC (16pin)

The VCC pin is used to supply power for the IC in the range of 9 to 35V.

If the VCC pin voltage reaches 7.5V (Typ.) or more, the IC will initiate operation. If it reaches 7.2V (Typ.) or less, the IC will be shut down.

Startup operation and soft start (SSFB) capacitance setting

The following section describes the sequence for the startup of this IC.

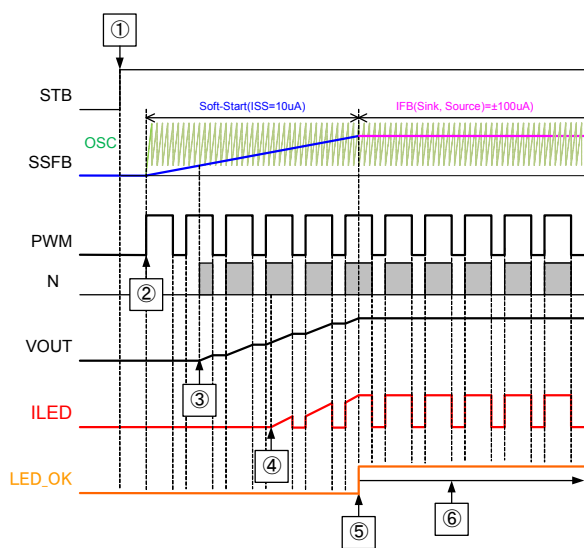

Figure 11. Startup waveform

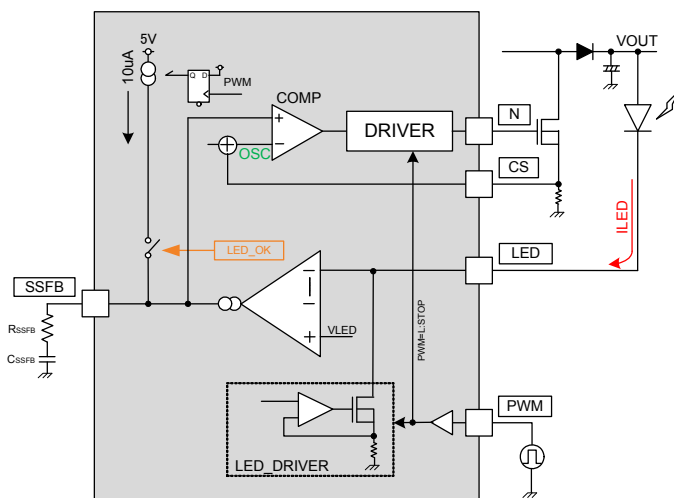

Figure 12. Circuit behavior at startup

ODescription of startup sequence

- (1) Set the STB and PWM pin to "ON".
- (2) Set all systems to "ON", SSFB charge will be initiated.
- (3) Since the SSFB pin reach the lower limit of the internal sawtooth wave of the IC, the DC/DC converter operates to start VOUT voltage rising.
- (4) The Vout voltage continues rising to reach a voltage at which LED current starts flowing.
- (5) When the LED current reaches the set amount of current, the startup operation is completed.
- (6) After that, conduct normal operation following the feedback operation sequence with the LED pins.
If the SSFB pin sink/source current is $\pm 100\mu\text{A}$, the LED protection function will be activated.

OSSFB capacitance setting procedure

As aforementioned, this IC stops DC/DC converter when the PWM pin is set to Low level and conducts step-up operation only in the section in which the PWM pin is maintained at High level. Consequently, setting the PWM duty cycle to the minimum will extend the startup time. The startup time also varies with application settings of output capacitance, LED current, output voltage, and others.

Startup time at minimum duty cycle can be approximated according to the following method:

Make measurement of VOUT startup time with a 100% duty cycle, first. Take this value as "Trise100".

The startup time "Trise_min" for the relevant application with the minimum duty cycle is given by the following equation.

$$T_{rise_min} = \frac{T_{rise_100}[\text{Sec}]}{\text{Min_Duty}[\text{ratio}]} \quad [\text{Sec}]$$

However, since this calculation method is just for approximation, use it only as a guide.

Assuming that the SSFB pin voltage is VSSFB, the time is given by the following equation:

$$T_{SSFB} = \frac{C_{SSFB}[\text{F}] \times V_{SSFB}[\text{V}]}{10[\mu\text{A}]} \quad [\text{Sec}]$$

As a result, it is recommended to make SSFB capacitance setting so that "T_{SSFB}" will be greater than "Trise_min"

About unused LED terminal automatic detecting function

This IC is detected automatically that it is an unused channel by assuming the LED terminal to be OPEN at starting. It explains the sequence.

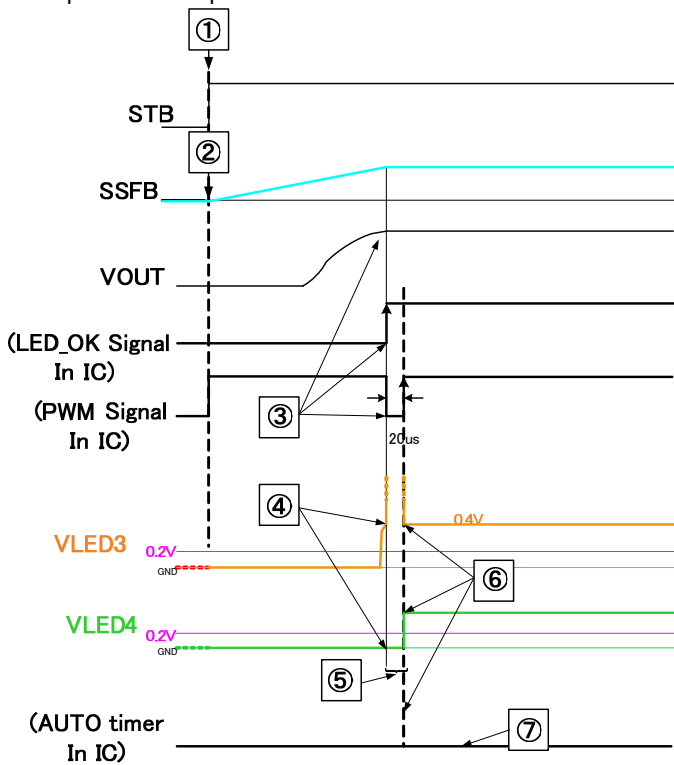

Figure 13. Timing chart

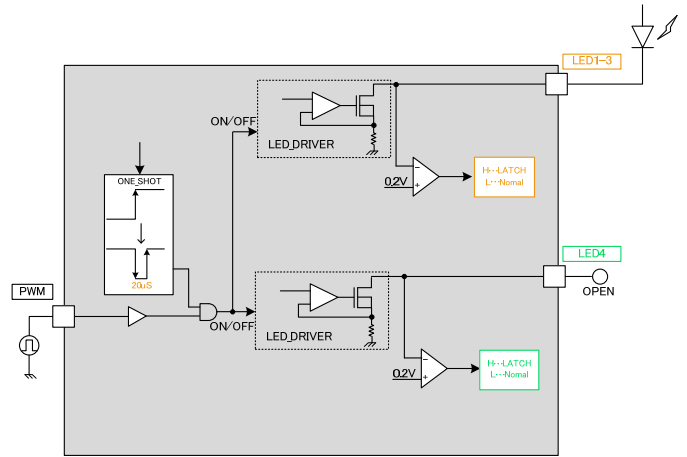

Figure 14. Block diagram

Sequence;

- ① STB=PWM=ON
- ② All systems are ON and SSFB starts charging.
- ③ When the output voltage is boosted enough, and enough current flows through the LED, LED_OK signal is switched in the IC. PWM=L from the Rise timing of this signal for about 20µs
- ④ During this PWM=L period, LED pins with LED connections' output voltage becomes 0.2V and above, where as unused LED pins are below 0.2V.
- ⑤ During this time, determination on whether the LED pins are 0.2V above/below is done.
- ⑥ After the determination, unused LED pins are pulled up to 5V.
- ⑦ The AUTO timer don't count.

LED current setting

Setting of LED output current "ILED" can be made by connecting a resistor R_{ISET} to the ISET pin.

ORISET vs. ILED current relation equation

$$R_{ISET} = \frac{7500}{I_{LED} [mA]} \quad [k\Omega] \quad (\text{ADIM}=2.5V)$$

However, LED current setting should be made in the range of 30mA to 150mA.

[Setting example]

To set ILED current to 100mA, R_{ISET} resistance is given by the following equation:

$$R_{ISET} = \frac{7500}{I_{LED} [mA]} = \frac{7500}{100 [mA]} = 75 \quad [k\Omega]$$

DC/DC converter drive frequency setting

DC/DC converter drive frequency is determined by making R_T resistance setting.

ODrive frequency vs. R_T resistance (ideal) relation equation

$$R_{RT} = \frac{15000}{f_{sw} [kHz]} \quad [k\Omega]$$

where f_{sw} = DC/DC converter oscillation frequency [kHz]

This equation has become an ideal equation without any correction item included.

For accurate frequency settings, thorough verification should be performed on practical sets.

[Setting example]

To set DC/DC drive frequency "f_{sw}" to 200 kHz, R_{RT} is given by the following equation:

$$R_{RT} = \frac{15000}{f_{sw} [kHz]} = \frac{15000}{200 [kHz]} = 75 \quad [k\Omega]$$

OVP/SCP Settings

OVP pin is DC/DC output voltage's over voltage protection and short circuit protection input pin.
 OVP pin is a high impedance pin with no pull down resistor. Thus, at OPEN state please set the voltage input settings using voltage dividing resistor and such.
 Respective OVP pin protection conditions are as below

Protection Name	Detection Pin	Detection Condition	Cancellation Condition	Timer Operations	Protection Type
OVP	OVP	OVP>3.0V	OVP<2.9V	No	DCDC stops during detection
SCP	OVP	OVP<0.1V	OVP>0.1V	Yes	All latch

○**OVP Detection Setting**

VO_{UT} abnormally increase, voltage detected by OVP, VO_{V_{DET}}, R1,R2 settings are as follows

$$R1 = R2[k\Omega] \times \frac{(VOVP_{DET}[V] - 3.0[V])}{3.0[V]} \quad [k\Omega]$$

○**OVP Cancellation Setting**

R1,R2 set from above equation, OVP cancellation voltage VO_{V_{CAN}} equals to

$$VOVP_{CAN} = 2.9V \times \frac{(R1[k\Omega] + R2[k\Omega])}{R2[k\Omega]} \quad [V]$$

○**SCP Detection Setting**

When R1,R2 are set using values obtained above, SCP voltage setting is V_{SCP_{DET}} is as follows

$$VSCP_{DET} = 0.1V \times \frac{(R1[k\Omega] + R2[k\Omega])}{R2[k\Omega]} \quad [V]$$

【Setting Example】

VO_{UT} at normal operation 56V, OVP detection voltage VO_{V_{DET}}=68V, R2=10k, R1 is as follows

$$R1 = R2[k\Omega] \times \frac{(VOVP_{DET}[V] - 3.0[V])}{3.0[V]} = 10[k\Omega] \times \frac{(68[V] - 3[V])}{3[V]} = 216.7 \quad [k\Omega]$$

When R1, R2 are set at these values, OVP cancellation voltage, VO_{V_{CAN}}

$$VOVP_{CAN} = 2.9[V] \times \frac{(R1[k\Omega] + R2[k\Omega])}{R2[k\Omega]} = 2.9[V] \times \frac{10[k\Omega] + 216.7[k\Omega]}{10[k\Omega]} [V] = 65.7 \quad [V]$$

In addition, at this R1, R2, SCP detection voltage

$$VSCP_{DET} = 0.1[V] \times \frac{(R1[k\Omega] + R2[k\Omega])}{R2[k\Omega]} = 0.1[V] \times \frac{10[k\Omega] + 216.7[k\Omega]}{10[k\Omega]} [V] = 2.27 \quad [V]$$

To select DC/DC components, give consideration to IC variations as well as individual component variations, and then conduct thorough verification on practical systems.

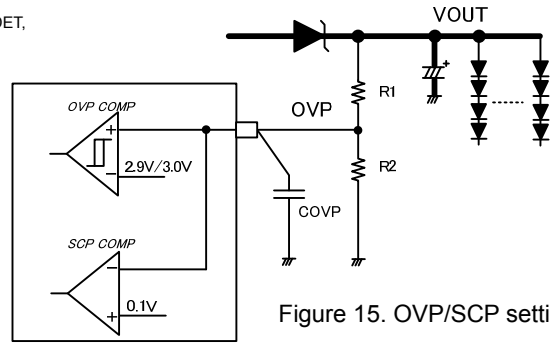

Figure 15. OVP/SCP setting example

Timer Latch Time Setting

This IC has a built-in timer latch counter. Timer latch time is set by counting the clock frequency which is set at the RT pin. After abnormal detection time passes, AUTO timer starts, it let IC auto-restart after constant setting time.

Timer Latch Time

When various abnormal conditions happen, counting starts from the timing, latch occurs after below time has passed. Furthermore, even if PWM=L, if abnormal condition continues, timer count will not reset.

$$LATCH_{TIME} = 2^{12} \times \frac{R_{RT}}{1.5 \times 10^{10}} = 4096 \times \frac{R_{RT} [k\Omega]}{1.5 \times 10^7} [s]$$

$$AUTO_{TIME} = 2^{17} \times \frac{R_{RT}}{1.5 \times 10^{10}} = 131072 \times \frac{R_{RT} [k\Omega]}{1.5 \times 10^7} [s]$$

Here, $LATCH_{TIME}$ = time until latch condition occurs, $AUTO_{TIME}$ = auto restart timer's time
 R_{RT} = Resistor value connected to RT pin

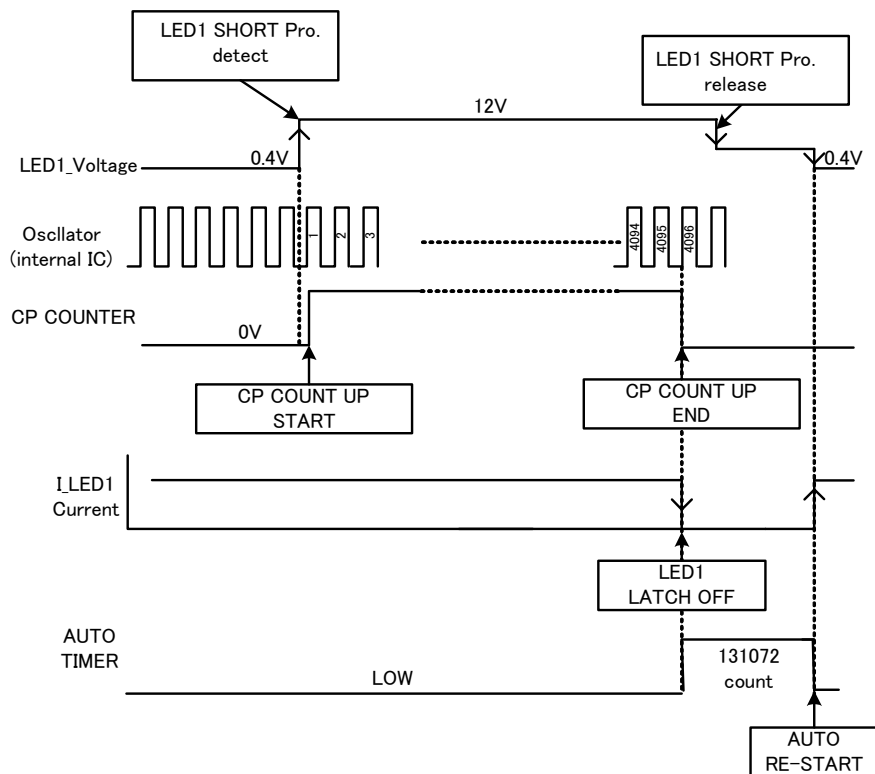

Figure 16. Example of LED Short protection timing chart

【Setting Example】

Timer latch time when $R_T=75k\Omega$

$$LATCH_{TIME} = 4096 \times \frac{R_{RT} [k\Omega]}{1.5 \times 10^7} = 4096 \times \frac{75 [k\Omega]}{1.5 \times 10^7} = 0.02 [s]$$

$$AUTO_{TIME} = 131072 \times \frac{R_{RT} [k\Omega]}{1.5 \times 10^7} = 131072 \times \frac{75 [k\Omega]}{1.5 \times 10^7} = 0.655 [s]$$

OCP Settings/DCDC Components' Current Capacity Selection Method

One of the function of CS pin - when its pin voltage>0.45 it stops the DCDC. Thus, RCS resistor value need to be checked after the peak current flow through the inductor is calculated. Furthermore, DCDC external components' current capacity needs to be greater than peak current flowing through this inductor.

(Inductor peak current Ipeak calculation method)

Firstly, ripple voltage which occurs at the CS pin is decided depending on the DCDC application conditions.

The conditions when made as below;

Output voltage=VOUT[V]

LED total current=IOUT[A]

DCDC input voltage=VIN[V]

DCDC efficiency =η[%]

Total required average input current IIN:

$$I_{IN} = \frac{V_{OUT}[V] \times I_{OUT}[A]}{V_{IN}[V] \times \eta[\%]} \quad [A]$$

Inductor ripple current IL[A] which occurs at inductor L[H] during DCDC drive operation with switching frequency=fsw[Hz] is as follows

$$\Delta IL = \frac{(V_{OUT}[V] - V_{IN}[V]) \times V_{IN}[V]}{L[H] \times V_{OUT}[V] \times f_{sw}[Hz]} \quad [A]$$

Therefore, IL's peak current Ipeak can be calculated using below equation

$$I_{peak} = I_{IN}[A] + \frac{\Delta IL[A]}{2} \quad [A] \dots (1)$$

(Resistor RCS connected to CS pin selection method)

This Ipeak flows in RCS and generates voltage. (refer to time chart diagram on the right). This voltage value, VCSpeak can be calculated as below

$$VCS_{peak} = Rcs \times I_{peak} \quad [V]$$

This VCSpeak when reach 0.45V, will stop the DCDC output. Thus when selecting RCS value, below condition needs to be met.

$$Rcs[\Omega] \times I_{peak}[A] < 0.45[V]$$

(DCDC Components' Current Capacity Selection Method)

When OCP reach detection voltage CS=0.45V, loCP current

$$I_{OCP} = \frac{0.45[V]}{Rcs[\Omega]} \quad [A] \dots (2)$$

Ipeak current (1), IOCP current (2), and components' MAX current capacity needs to satisfy the following

$$I_{peak} < I_{OCP} < \text{Rated current of components}$$

Above condition needs to be satisfied when selecting DCDC application parts eg. FET, inductor, diode etc. Furthermore, continuous mode is recommended for normal DCDC applications. Inductor's ripple current MIN limit value, Imin becoming

$$I_{min} = I_{IN}[A] - \frac{\Delta IL[A]}{2} [A] > 0$$

Is a condition to be met. If this is not met, it is called discontinuous mode.

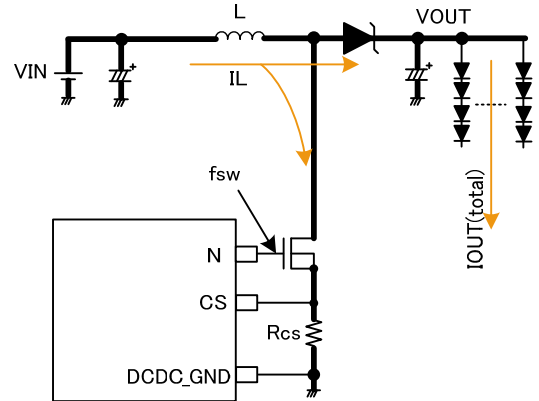

Figure 17. DC/DC converter application circuit

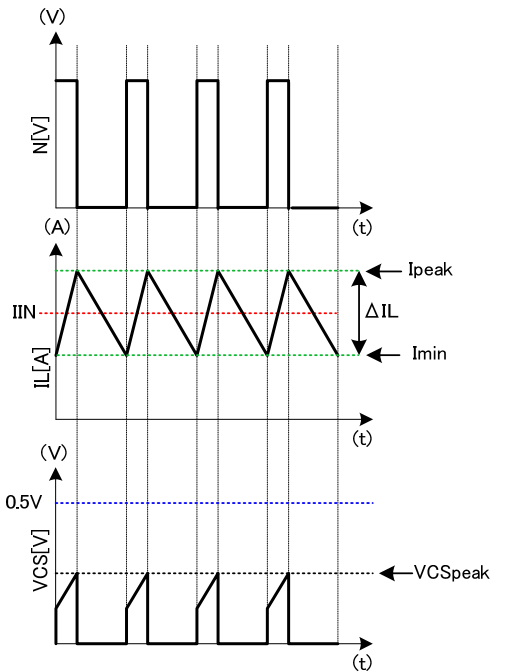

Figure 18. Inductor current waveform

【Setting Example】

Output voltage=VOUT[V]=56V
 LED total current=IOUT[A]=100mA×4ch=0.40A
 DCDC input voltage=VIN[V]=14V
 DCDC efficiency=η[%]=90%
 Total required average input current IIN:

$$I_{IN}[A] = \frac{V_{OUT}[V] \times I_{OUT}[A]}{V_{IN}[V] \times \eta[\%]} = \frac{56[V] \times 0.40[A]}{14[V] \times 90[\%]} = 1.78 [A]$$

When, DCDC switching frequency =fsw[Hz]=200kHz
 Inductor L[H]=33uH,
 Inductor ripple current ΔIL[A]:

$$\Delta IL = \frac{(V_{OUT}[V] - V_{IN}[V]) \times V_{IN}[V]}{L[H] \times V_{OUT}[V] \times f_{sw}[Hz]} = \frac{(56[V] - 14[V]) \times 14[V]}{33 \times 10^{-6}[H] \times 56[V] \times 200 \times 10^3[Hz]} = 1.59 [A]$$

Thus, IL peak current Ipeak becomes

$$I_{peak} = I_{IN}[A] + \frac{\Delta IL[A]}{2} [A] = 1.78[A] + \frac{1.59[A]}{2} = 2.58 [A] \quad \dots\text{Peak current calculation result}$$

RCS resistor value when set at 0.1ohm

$$VCS_{peak} = Rcs \times I_{peak} = 0.10[\Omega] \times 2.58[A] = 0.258 [V] < 0.45V \quad \dots\text{RCS resistor consideration}$$

and satisfy the condition.

In addition, OCP detection current I_{OCP} at this time is

$$I_{OCP} = \frac{0.45[V]}{0.1[\Omega]} = 4.5 [A]$$

If parts used (FET, INDUCTOR, DIODE etc)'s current capacity < 5A,

$$I_{peak} < I_{OCP} < \text{Rated current of components} = 2.58[A] < 4.5[A] < 5[A]$$

...DCDC current capacity consideration

Thus, there is no problem of parts selection as the above condition is satisfied.

In addition, IL ripple current minimum limit I_{min} is

$$I_{min} = I_{IN}[A] - \frac{\Delta IL[A]}{2} [A] = 1.78[A] - 0.795[A] = 0.985[A] > 0$$

Thus, will not become discontinuous mode.

To select DC/DC components, give consideration to IC variations as well as individual component variations, and then conduct thorough verification on practical systems.

Selection of inductor L

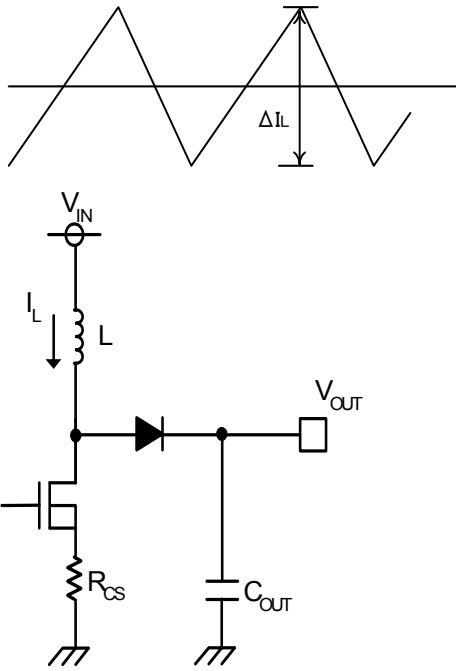

The value of inductor has significant influence on the input ripple current. As shown by Equation (1), the larger the inductor and the higher the switching frequency, the inductor ripple current ΔIL becomes increasingly lower.

$$\Delta IL = \frac{(V_{OUT} - V_{IN}) \times V_{IN}}{L \times V_{OUT} \times f_{SW}} [A] \quad \dots \dots (1)$$

Expressing efficiency as shown by Equation (2), peak input current is given as Equation (3).

$$\eta = \frac{V_{OUT} \times I_{OUT}}{V_{IN} \times I_{IN}} \quad \dots \dots (2)$$

$$IL_{MAX} = I_{IN} + \frac{\Delta IL}{2} = \frac{V_{OUT} \times I_{OUT}}{V_{IN} \times \eta} + \frac{\Delta IL}{2} \quad \dots \dots (3)$$

where, L: Reactance value [H],
 V_{OUT} : DC/DC output voltage [V],
 V_{IN} : Input voltage [V],
 I_{OUT} : Output load current (total output current) [A],
 I_{IN} : Input current [A], and
 F_{SW} : Oscillation frequency [Hz]

Figure 19. Inductor current waveform and diagram

Note: If a current in excess of the rated current of the inductor applies to the coil, the inductor will cause magnetic saturation, resulting in efficiency degradation.

Select an inductor with an adequate margin so that peak current will not exceed the rated current of the inductor.

Note: To reduce power dissipation from and increase efficiency of inductor, select an inductor with low resistance component (DCR or ACR).

Selection of output capacitor C_{OUT}

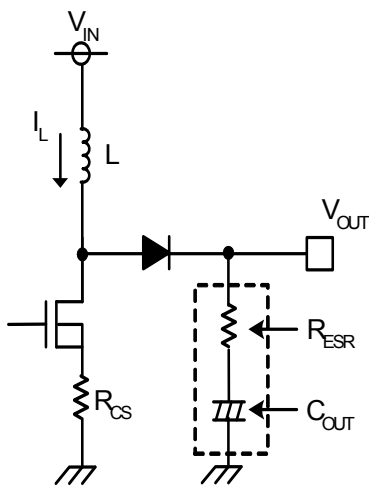

Select a capacitor on the output side taking into account the stability region of output voltage and equivalent series resistance necessary to smooth ripple voltage. Note that higher output ripple voltage may result in a drop in LED pin voltage, making it impossible to supply set LED current.

The output ripple voltage ΔV_{OUT} is given by Equation (4).

$$\Delta V_{OUT} = IL_{MAX} \times R_{ESR} + \frac{1}{C_{OUT}} \times \frac{I_{OUT}}{\eta} \times \frac{1}{f_{SW}} [V] \quad \dots \dots (4)$$

where R_{ESR} = Equivalent series resistance of C_{OUT} .

Note: Select capacitor ratings with an adequate margin for output voltage.

Note: To use an electrolytic capacitor, an adequate margin should be provided for permissible current. Particularly to apply PWM light modulation to LED, note that a current higher than the set LED current transiently flows.

Figure 20. Output capacitor diagram,

Selection of switching MOSFET transistors

There will be no problem for switching MOSFET transistors having absolute maximum rating higher than rated current of the inductor L and VF higher than " C_{OUT} breakdown voltage + Rectifier diode". However, to achieve high-speed switching, select transistors with small gate capacity (injected charge amount).

Note: Rated current larger than over current protection setting current is recommended.

Note: Selecting transistors with low on resistance can obtain high efficiency.

Selection of rectifier diodes

Select Schottky barrier diodes having current capability higher than the rated current of the inductor L and inverse breakdown voltage higher than C_{OUT} breakdown voltage, particularly having low forward voltage VF.

Phase Compensation Setting Procedure

DC/DC converter application for current mode control includes one each of pole f_p (phase delay) by CR filter consisting of output capacitor and output resistor (i.e., LED current) and zero (phase lead) f_z by the output capacitor and capacitor ESR. Furthermore, the step-up DC/DC converter includes RHP zero " f_{ZRHP} " as the second zero. Since the RHP zero has phase delay (-90°) characteristics like the pole, the crossover frequency f_c should be set to not more than RHP zero

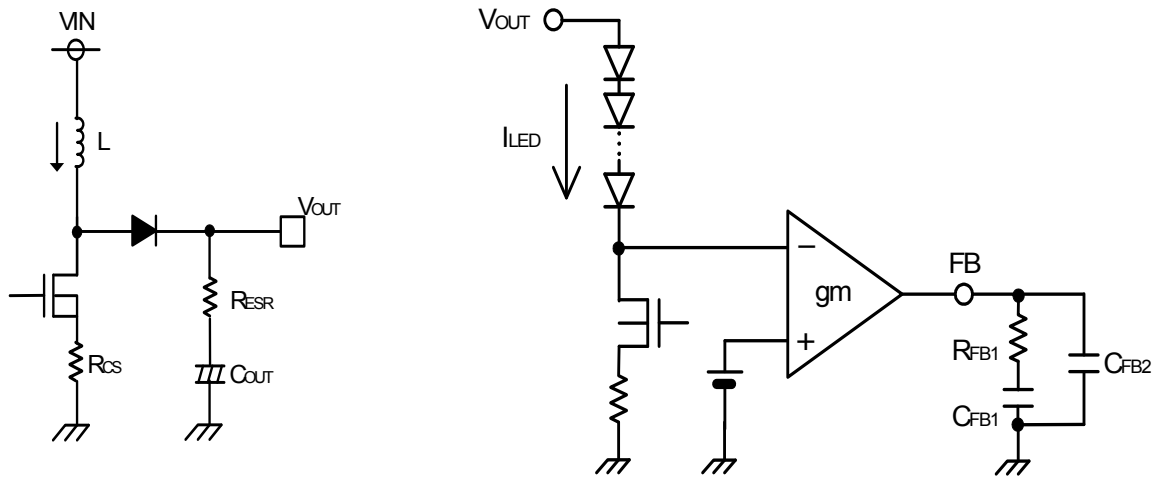

Figure 21. Output stage and error amplifier diagram

- i. Find pole f_p and RHP zero f_{ZRHP} of DC/DC converter.

$$f_p = \frac{I_{LED}}{2\pi \times V_{OUT} \times C_{OUT}} [Hz] \quad f_{ZRHP} = \frac{V_{OUT} \times (1-D)^2}{2\pi \times L \times I_{LED}} [Hz]$$

Where I_{LED} = Total LED current [A], $D = \frac{V_{OUT} - V_{IN}}{V_{OUT}}$

- ii. Find phase compensation to be inserted in the error amplifier. (Set f_c to 1/5 of f_{ZRHP} .)

$$R_{FB1} = \frac{f_{RHZP} \times R_{CS} \times I_{LED}}{5 \times f_p \times gm \times V_{OUT} \times (1-D)} [\Omega]$$

$$C_{FB1} = \frac{1}{2\pi \times R_{FB1} \times f_c} = \frac{5}{2\pi \times R_{FB1} \times f_{ZRHP}} [F]$$

where $gm = 4.0 \times 10^{-4} [S]$

- iii. Find zero used to compensate ESR (R_{ESR}) of C_{OUT} (electrolytic capacitor).

$$C_{FB2} = \frac{R_{ESR} \times C_{OUT}}{R_{FB1}} [F]$$

Note: Even if a ceramic capacitor (R_{ESR} of the order of milliohms) for C_{OUT} , it is recommended to insert C_{FB2} for stable operation.

To improve transient response, it is necessary to increase R_{FB1} and reduce C_{FB1} . However, this improvement reduces a phase margin. To avoid this problem, conduct thorough verification, including variations in external components, on practical systems.

Timing Chart

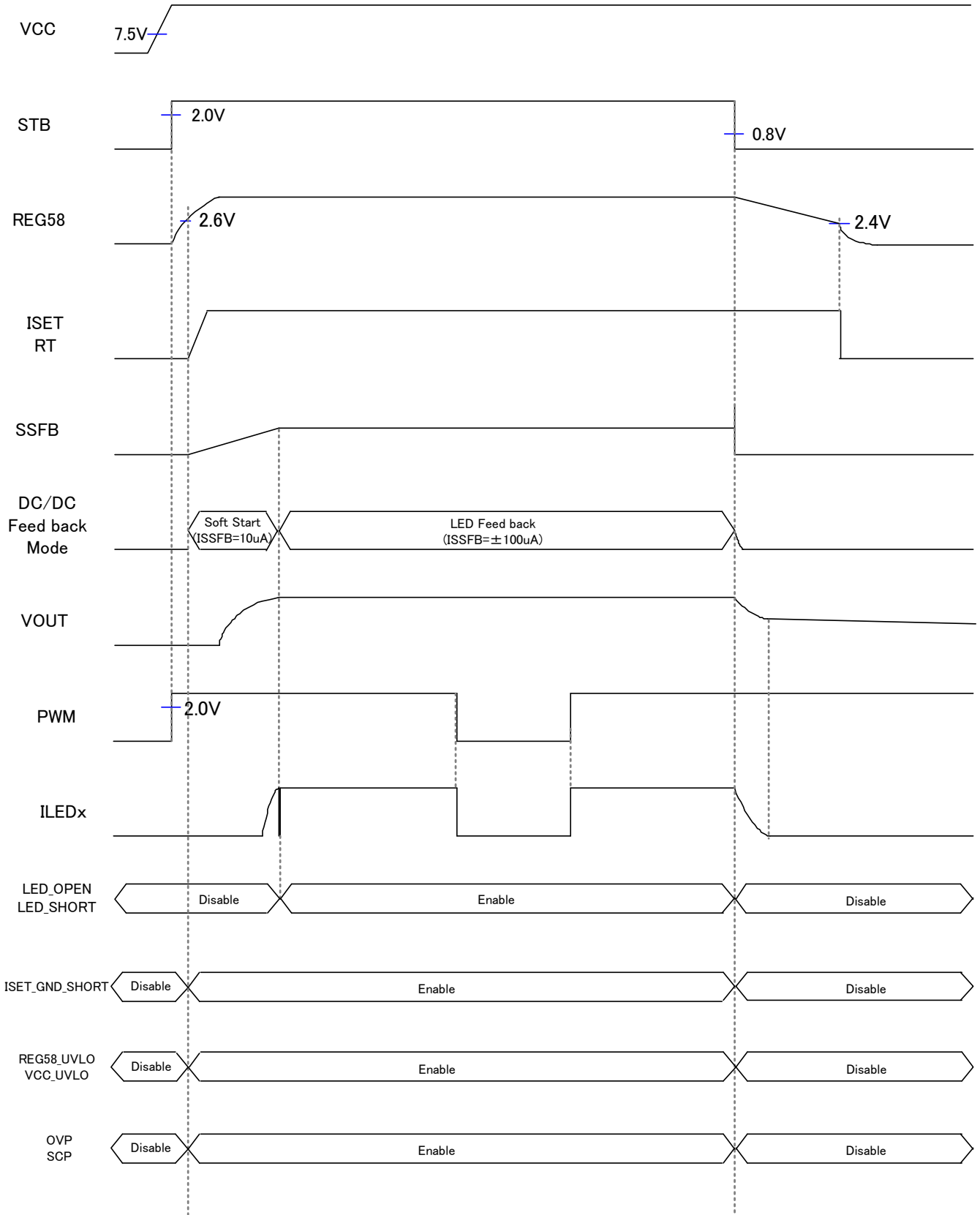

Figure 22. Timing chart

List of Protect Function (typ condition)

Protection Name	Detection Pin	Detection Conditions			Cancellation Conditions	Timer	Protection Type
		Detection pin	PWM	LED_OK			
LED OPEN	LEDx	LEDx < 0.2V	H	After LED_OK	LEDx > 0.2V	2 ¹² count	Immediately Auto-Restart after detection (Judge periodically whether normal or not)
LED SHORT	LEDx	LEDx > 5V	H	After LED_OK	LEDx < 5V	2 ¹² count	Immediately Auto-Restart after detection (Judge periodically whether normal or not)
LED GND SHORT	LEDx	LEDx < 0.2V and SSFB > 4.0V	H	-	LEDx > 0.2V or SSFB < 3.6V	(2 ¹² +2 ⁷) count	Latch
ISET GND SHORT	ISET	Under ISET×90%	-	-	Above ISET×90%	Immediately Detect	Auto-Restart
REG58 UVLO	REG58	REG58<2.4V	-	-	REG58>2.6V	Immediately Detect	Auto-Restart
VCC UVLO	VCC	VCC<7.3V	-	-	VCC>7.5V	Immediately Detect	Auto-Restart
OVP	OVP	OVP>3.0V	-	-	OVP<2.9V	Immediately Detect	Auto-Restart
SCP	OVP	OVP<0.1V	-	-	OVP>0.1V	2 ¹² count	Auto-Restart
OCP	CS	OCP>0.45V	-	-	-	Immediately Detect	Pulse-by-Pulse

To clear the latch type, STB should be set to "L" once, and then to "H".

Protection Function	Operation after the protection function detected		
	DC/DC	LED Driver	Soft-start
LED OPEN	Continue to operate	Only detected LED ch stops after CP count	Continue to operate
LED SHORT	Continue to operate	Only detected LED ch stops after CP count	Continue to operate
LED GND SHORT	Stop after (CP+2 ⁷) count	Only detected LED ch stops after CP count Other LED ch stop operation after (CP+2 ⁷) count	Discharge after (CP+2 ⁷) count
ISET GND SHORT	Stop immediately	Stop immediately	Continue to operate
STB	Stop immediately	Stop (and when REG58<2.4V)	Discharge immediately
REG58 UVLO	Stop immediately	Stop immediately	Discharge immediately
VCC UVLO	Stop immediately	Stop immediately	Discharge immediately
OVP	Stop immediately (N pin only)	Continue to operate	Continue to operate
SCP	Stop immediately (N pin only)	Stop after CP count	Discharge after CP count
OCP	N pin limits DUTY	Continue to operate	Continue to operate

* CP= 20ms (RT=75KΩ)

Operational Notes

1. Reverse Connection of Power Supply

Connecting the power supply in reverse polarity can damage the IC. Take precautions against reverse polarity when connecting the power supply, such as mounting an external diode between the power supply and the IC's power supply terminals.

2. Power Supply Lines

Design the PCB layout pattern to provide low impedance supply lines. Separate the ground and supply lines of the digital and analog blocks to prevent noise in the ground and supply lines of the digital block from affecting the analog block. Furthermore, connect a capacitor to ground at all power supply pins. Consider the effect of temperature and aging on the capacitance value when using electrolytic capacitors.

3. Ground Voltage

Ensure that no pins are at a voltage below that of the ground pin at any time, even during transient condition.

4. Ground Wiring Pattern

When using both small-signal and large-current ground traces, the two ground traces should be routed separately but connected to a single ground at the reference point of the application board to avoid fluctuations in the small-signal ground caused by large currents. Also ensure that the ground traces of external components do not cause variations on the ground voltage. The ground lines must be as short and thick as possible to reduce line impedance.

5. Thermal Consideration

Should by any chance the power dissipation rating be exceeded the rise in temperature of the chip may result in deterioration of the properties of the chip. The absolute maximum rating of the Pd stated in this specification is when the IC is mounted on a 70mm x 70mm x 1.6mm glass epoxy board. In case of exceeding this absolute maximum rating, increase the board size and copper area to prevent exceeding the Pd rating.

6. Recommended Operating Conditions

These conditions represent a range within which the expected characteristics of the IC can be approximately obtained. The electrical characteristics are guaranteed under the conditions of each parameter.

7. Rush Current

When power is first supplied to the IC, it is possible that the internal logic may be unstable and inrush current may flow instantaneously due to the internal powering sequence and delays, especially if the IC has more than one power supply. Therefore, give special consideration to power coupling capacitance, power wiring, width of ground wiring, and routing of connections.

8. Testing on Application Boards

When testing the IC on an application board, connecting a capacitor directly to a low-impedance output pin may subject the IC to stress. Always discharge capacitors completely after each process or step. The IC's power supply should always be turned off completely before connecting or removing it from the test setup during the inspection process. To prevent damage from static discharge, ground the IC during assembly and use similar precautions during transport and storage.

9. Inter-pin Short and Mounting Errors

Ensure that the direction and position are correct when mounting the IC on the PCB. Incorrect mounting may result in damaging the IC. Avoid nearby pins being shorted to each other especially to ground, power supply and output pin. Inter-pin shorts could be due to many reasons such as metal particles, water droplets (in very humid environment) and unintentional solder bridge deposited in between pins during assembly to name a few.

Operational Notes – continued

10. Unused Input Terminals

Input terminals of an IC are often connected to the gate of a MOS transistor. The gate has extremely high impedance and extremely low capacitance. If left unconnected, the electric field from the outside can easily charge it. The small charge acquired in this way is enough to produce a significant effect on the conduction through the transistor and cause unexpected operation of the IC. So unless otherwise specified, unused input terminals should be connected to the power supply or ground line.

11. Regarding the Input Pin of the IC

This monolithic IC contains P+ isolation and P substrate layers between adjacent elements in order to keep them isolated. P-N junctions are formed at the intersection of the P layers with the N layers of other elements, creating a parasitic diode or transistor. For example (refer to figure below):

When $GND > Pin\ A$ and $GND > Pin\ B$, the P-N junction operates as a parasitic diode.

When $GND > Pin\ B$, the P-N junction operates as a parasitic transistor.

Parasitic diodes inevitably occur in the structure of the IC. The operation of parasitic diodes can result in mutual interference among circuits, operational faults, or physical damage. Therefore, conditions that cause these diodes to operate, such as applying a voltage lower than the GND voltage to an input pin (and thus to the P substrate) should be avoided.

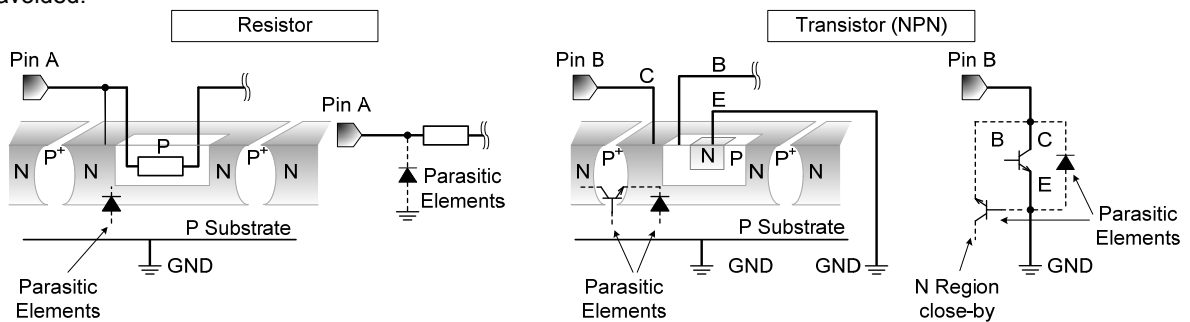

Figure 23. Example of monolithic IC structure

12. Ceramic Capacitor

When using a ceramic capacitor, determine the dielectric constant considering the change of capacitance with temperature and the decrease in nominal capacitance due to DC bias and others.

13. Area of Safe Operation (ASO)

Operate the IC such that the output voltage, output current, and power dissipation are all within the Area of Safe Operation (ASO).

14. Thermal Shutdown Circuit(TSD)

This IC has a built-in thermal shutdown circuit that prevents heat damage to the IC. Normal operation should always be within the IC's power dissipation rating. If however the rating is exceeded for a continued period, the junction temperature (T_j) will rise which will activate the TSD circuit that will turn OFF all output pins. When the T_j falls below the TSD threshold, the circuits are automatically restored to normal operation.

Note that the TSD circuit operates in a situation that exceeds the absolute maximum ratings and therefore, under no circumstances, should the TSD circuit be used in a set design or for any purpose other than protecting the IC from heat damage.

15. Over Current Protection Circuit (OCP)

This IC incorporates an integrated overcurrent protection circuit that is activated when the load is shorted. This protection circuit is effective in preventing damage due to sudden and unexpected incidents. However, the IC should not be used in applications characterized by continuous operation or transitioning of the protection circuit.

Ordering Information

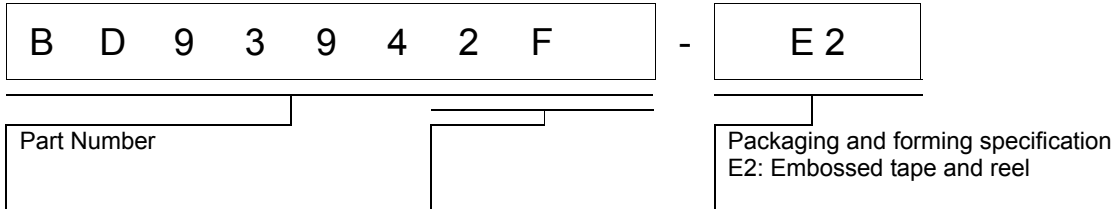

Marking Diagrams

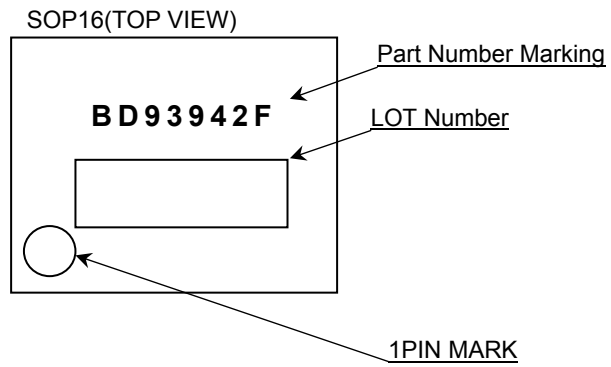

Physical Dimension, Tape and Reel Information

Package Name	SOP16
--------------	-------

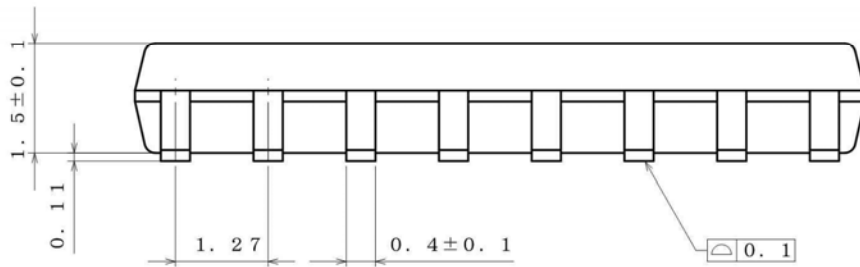
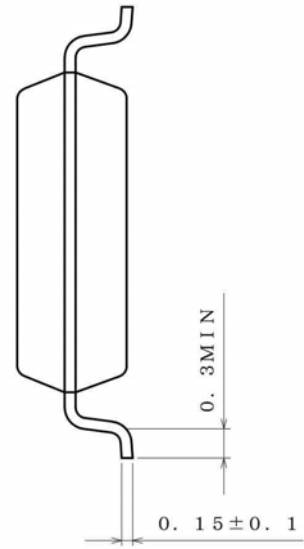
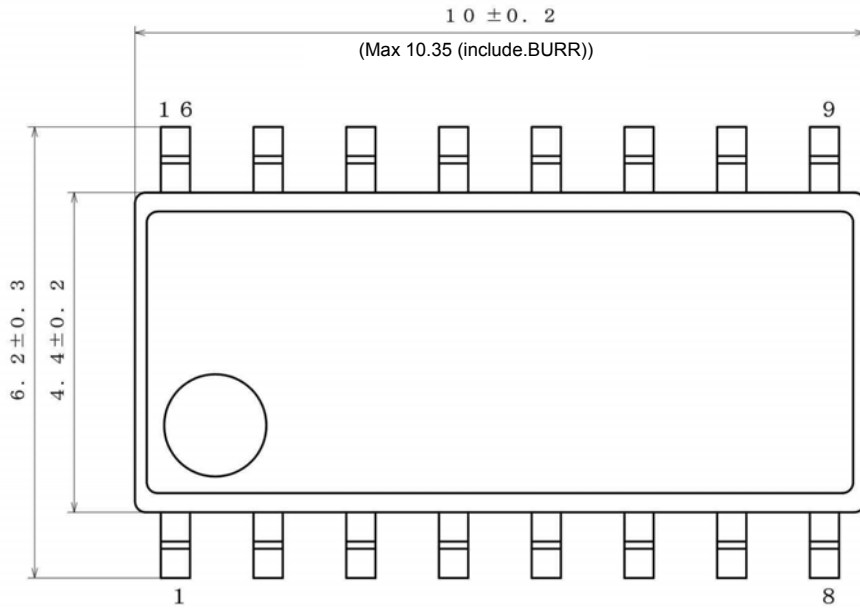

(UNIT : mm)
PKG : SOP16
Drawing No. : EX114-5001

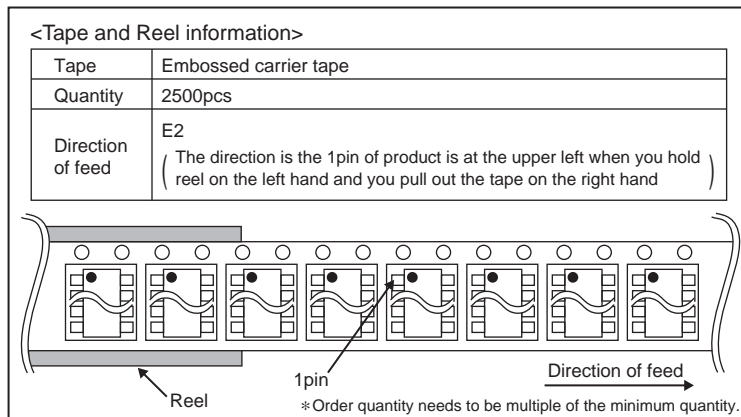

Revision History

Date	Revision	Changes
12.Feb.2015	001	New release
12.Aug.2015	002	p.3 [REG58 Block] Soft start completion voltage -> REG58 available current

Notice

Precaution on using ROHM Products

- Our Products are designed and manufactured for application in ordinary electronic equipments (such as AV equipment, OA equipment, telecommunication equipment, home electronic appliances, amusement equipment, etc.). If you intend to use our Products in devices requiring extremely high reliability (such as medical equipment ^(Note 1), transport equipment, traffic equipment, aircraft/spacecraft, nuclear power controllers, fuel controllers, car equipment including car accessories, safety devices, etc.) and whose malfunction or failure may cause loss of human life, bodily injury or serious damage to property ("Specific Applications"), please consult with the ROHM sales representative in advance. Unless otherwise agreed in writing by ROHM in advance, ROHM shall not be in any way responsible or liable for any damages, expenses or losses incurred by you or third parties arising from the use of any ROHM's Products for Specific Applications.

(Note1) Medical Equipment Classification of the Specific Applications

JAPAN	USA	EU	CHINA
CLASS III	CLASS III	CLASS II b	CLASS III
CLASS IV		CLASS III	

- ROHM designs and manufactures its Products subject to strict quality control system. However, semiconductor products can fail or malfunction at a certain rate. Please be sure to implement, at your own responsibilities, adequate safety measures including but not limited to fail-safe design against the physical injury, damage to any property, which a failure or malfunction of our Products may cause. The following are examples of safety measures:
 - Installation of protection circuits or other protective devices to improve system safety
 - Installation of redundant circuits to reduce the impact of single or multiple circuit failure
- Our Products are designed and manufactured for use under standard conditions and not under any special or extraordinary environments or conditions, as exemplified below. Accordingly, ROHM shall not be in any way responsible or liable for any damages, expenses or losses arising from the use of any ROHM's Products under any special or extraordinary environments or conditions. If you intend to use our Products under any special or extraordinary environments or conditions (as exemplified below), your independent verification and confirmation of product performance, reliability, etc. prior to use, must be necessary:
 - Use of our Products in any types of liquid, including water, oils, chemicals, and organic solvents
 - Use of our Products outdoors or in places where the Products are exposed to direct sunlight or dust
 - Use of our Products in places where the Products are exposed to sea wind or corrosive gases, including Cl₂, H₂S, NH₃, SO₂, and NO₂
 - Use of our Products in places where the Products are exposed to static electricity or electromagnetic waves
 - Use of our Products in proximity to heat-producing components, plastic cords, or other flammable items
 - Sealing or coating our Products with resin or other coating materials
 - Use of our Products without cleaning residue of flux (even if you use no-clean type fluxes, cleaning residue of flux is recommended); or Washing our Products by using water or water-soluble cleaning agents for cleaning residue after soldering
 - Use of the Products in places subject to dew condensation
- The Products are not subject to radiation-proof design.
- Please verify and confirm characteristics of the final or mounted products in using the Products.
- In particular, if a transient load (a large amount of load applied in a short period of time, such as pulse. is applied, confirmation of performance characteristics after on-board mounting is strongly recommended. Avoid applying power exceeding normal rated power; exceeding the power rating under steady-state loading condition may negatively affect product performance and reliability.
- De-rate Power Dissipation (Pd) depending on Ambient temperature (Ta). When used in sealed area, confirm the actual ambient temperature.
- Confirm that operation temperature is within the specified range described in the product specification.
- ROHM shall not be in any way responsible or liable for failure induced under deviant condition from what is defined in this document.

Precaution for Mounting / Circuit board design

- When a highly active halogenous (chlorine, bromine, etc.) flux is used, the residue of flux may negatively affect product performance and reliability.
- In principle, the reflow soldering method must be used on a surface-mount products, the flow soldering method must be used on a through hole mount products. If the flow soldering method is preferred on a surface-mount products, please consult with the ROHM representative in advance.

For details, please refer to ROHM Mounting specification

Precautions Regarding Application Examples and External Circuits

1. If change is made to the constant of an external circuit, please allow a sufficient margin considering variations of the characteristics of the Products and external components, including transient characteristics, as well as static characteristics.
2. You agree that application notes, reference designs, and associated data and information contained in this document are presented only as guidance for Products use. Therefore, in case you use such information, you are solely responsible for it and you must exercise your own independent verification and judgment in the use of such information contained in this document. ROHM shall not be in any way responsible or liable for any damages, expenses or losses incurred by you or third parties arising from the use of such information.

Precaution for Electrostatic

This Product is electrostatic sensitive product, which may be damaged due to electrostatic discharge. Please take proper caution in your manufacturing process and storage so that voltage exceeding the Products maximum rating will not be applied to Products. Please take special care under dry condition (e.g. Grounding of human body / equipment / solder iron, isolation from charged objects, setting of Ionizer, friction prevention and temperature / humidity control).

Precaution for Storage / Transportation

1. Product performance and soldered connections may deteriorate if the Products are stored in the places where:
 - [a] the Products are exposed to sea winds or corrosive gases, including Cl₂, H₂S, NH₃, SO₂, and NO₂
 - [b] the temperature or humidity exceeds those recommended by ROHM
 - [c] the Products are exposed to direct sunshine or condensation
 - [d] the Products are exposed to high Electrostatic
2. Even under ROHM recommended storage condition, solderability of products out of recommended storage time period may be degraded. It is strongly recommended to confirm solderability before using Products of which storage time is exceeding the recommended storage time period.
3. Store / transport cartons in the correct direction, which is indicated on a carton with a symbol. Otherwise bent leads may occur due to excessive stress applied when dropping of a carton.
4. Use Products within the specified time after opening a humidity barrier bag. Baking is required before using Products of which storage time is exceeding the recommended storage time period.

Precaution for Product Label

QR code printed on ROHM Products label is for ROHM's internal use only.

Precaution for Disposition

When disposing Products please dispose them properly using an authorized industry waste company.

Precaution for Foreign Exchange and Foreign Trade act

Since concerned goods might be fallen under listed items of export control prescribed by Foreign exchange and Foreign trade act, please consult with ROHM in case of export.

Precaution Regarding Intellectual Property Rights

1. All information and data including but not limited to application example contained in this document is for reference only. ROHM does not warrant that foregoing information or data will not infringe any intellectual property rights or any other rights of any third party regarding such information or data.
2. ROHM shall not have any obligations where the claims, actions or demands arising from the combination of the Products with other articles such as components, circuits, systems or external equipment (including software).
3. No license, expressly or implied, is granted hereby under any intellectual property rights or other rights of ROHM or any third parties with respect to the Products or the information contained in this document. Provided, however, that ROHM will not assert its intellectual property rights or other rights against you or your customers to the extent necessary to manufacture or sell products containing the Products, subject to the terms and conditions herein.

Other Precaution

1. This document may not be reprinted or reproduced, in whole or in part, without prior written consent of ROHM.
2. The Products may not be disassembled, converted, modified, reproduced or otherwise changed without prior written consent of ROHM.
3. In no event shall you use in any way whatsoever the Products and the related technical information contained in the Products or this document for any military purposes, including but not limited to, the development of mass-destruction weapons.
4. The proper names of companies or products described in this document are trademarks or registered trademarks of ROHM, its affiliated companies or third parties.

General Precaution

1. Before you use our Products, you are requested to carefully read this document and fully understand its contents. ROHM shall not be in any way responsible or liable for failure, malfunction or accident arising from the use of any ROHM's Products against warning, caution or note contained in this document.
2. All information contained in this document is current as of the issuing date and subject to change without any prior notice. Before purchasing or using ROHM's Products, please confirm the latest information with a ROHM sales representative.
3. The information contained in this document is provided on an "as is" basis and ROHM does not warrant that all information contained in this document is accurate and/or error-free. ROHM shall not be in any way responsible or liable for any damages, expenses or losses incurred by you or third parties resulting from inaccuracy or errors of or concerning such information.

Mouser Electronics

Authorized Distributor

Click to View Pricing, Inventory, Delivery & Lifecycle Information:

[ROHM Semiconductor:](#)

[BD93942F-GE2](#)