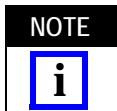

Figure 1

1. INTRODUCTION

Pneumatic Power Bench Assembly 58338-1 is a pneumatic power unit designed to accept a variety of interchangeable terminating heads or feed track assemblies that terminate unstripped wire in connectors.

Refer to the instructions packaged with the terminating head or feed track assembly for proper selection, setup and adjustment procedures, terminating and test procedures, and maintenance. Read this and all referenced materials carefully before using the power bench assembly.



*Dimensions in this instruction sheet are in metric units [with U.S. customary units in brackets].
Figures are for reference only and are not drawn to scale.*

Reasons for reissue of this instruction sheet are provided in Section 9, REVISION SUMMARY.

2. SAFETY PRECAUTIONS AND COMPANY CONTACT

2.1. Safety

Safeguards are designed into this application equipment to protect operators and maintenance personnel from most hazards during equipment operation. However, certain safety precautions must be taken by the operator and repair personnel to avoid personal injury, as well as damage to the equipment. For best results, application equipment must be operated in a dry, dust-free environment. Do not

operate equipment in a gaseous or hazardous environment.

Carefully observe the following safety precautions before and during operation of the equipment:

- ALWAYS wear appropriate ear protection.
- ALWAYS wear approved eye protection when operating powered equipment.
- ALWAYS keep guard(s) in place during normal operation.
- ALWAYS disconnect the tool from its power source when performing maintenance on the equipment.
- NEVER wear loose clothing or jewelry that may catch in moving parts of the application equipment.
- NEVER insert hands into installed application equipment.
- NEVER alter, modify, or misuse the application equipment.

2.2. Contact

CALL TOLL FREE 1-800-722-1111 (CONTINENTAL UNITED STATES AND PUERTO RICO ONLY)

The Tooling Assistance Center offers a means of providing technical assistance when required.

In addition, Field Service Specialists are available to provide assistance in the adjustment or repair of the application equipment when problems arise which your maintenance personnel are unable to correct.

When calling the Tooling Assistance Center regarding service to equipment, it is suggested that a person familiar with the device be present with a copy of the manual (and drawings) to receive instructions. Many difficulties can be avoided in this manner.

When calling the Tooling Assistance Center, be ready with the following information:

1. Customer name
2. Customer address
3. Person to contact (name, title, telephone number, and extension)
4. Person calling
5. Equipment number (and serial number if applicable)
6. Product part number (and serial number if applicable)
7. Urgency of request
8. Nature of problem

9. Description of inoperative component(s)

10. Additional information/comments that may be helpful



Read and understand the entire manual before using the tool.



Always wear appropriate eye protection when using the tool.



Always disconnect the air and lockout the tool when not in use, when performing maintenance on the tool, or when clearing a jammed tool.



Pinch point warning: Keep hands clear of moving parts during operation.



This unit should only be operated by trained personnel.



If not using quick-disconnect fittings to connect the tool to the air supply, provide operators other means to easily disconnect the tool from the air supply.



This tool is not insulated for coming into contact with electric power sources.



Do not use this tool in explosive atmospheres.



Stored gas or fluid energy may cause a hazard.

Read these instructions thoroughly before operating any of the pneumatic tools. The performance of these tools will depend largely upon the intelligent use of the information contained in these instructions. Pay

particular attention to DANGER, CAUTION, NOTE, and SAFETY statements.



Denotes an imminent hazard which may result in moderate or severe injury.



Denotes a condition which may result in product or equipment damage.



Highlights special or important information.

3. DESCRIPTION (see Figure 2)

The power bench assembly consists of a bench mount with an attached pneumatic power assembly, a foot switch, and air tubes which connect the foot switch to the power assembly and the air source to the foot switch.

The bench mount is attached to a bench or work table with screws or clamps and the foot switch is used to actuate the power assembly when connected to an air source.

In this use, the pneumatic power bench assembly emits a noise level less than 70 dB and the vibration level is less than 2.5 mm/s².

4. INSTALLATION



To avoid personal injury, ALWAYS disconnect handle assembly from the air supply when installing or removing the bench mount.

The bench mount is designed to be mounted in either of the two positions shown in Figure 2. Orientation of the bench mount depends on operator preference and the desired eject direction of terminated connector (refer to Figure 4). Install the bench mount as follows:

1. Place the bench mount on a bench or work table in the desired location and orientation.
2. Mark the location for the screws in the bench surface through the drilled holes of the bench mount flange. Drill holes for the mounting screws.

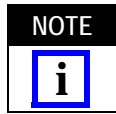

Mounting hardware is not supplied with the power bench assembly and must be supplied by the customer.

3. Secure the screws.

4. Connect the air tube to an approved air source. It is recommended that a filter-regulator-lubricator unit with the lubricator adjusted to the minimum setting be used with the power bench assembly. Refer to Figure 3. It is also recommended that quick-disconnect fittings are used to connect the tool to the air-supply. If not using quick-disconnect fittings, provide a pneumatic lock-out on the air line that bleeds air after it is turned off.

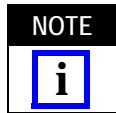

The power assembly is designed to operate at an air pressure range of 276 through 483 kPa [40 through 70 psi]. Service life of the power assembly can be greatly extended when only the necessary air pressure is applied. Excessive pressure causes unnecessary wear and strain on the power assembly, terminating head or feed track assembly, and connectors.

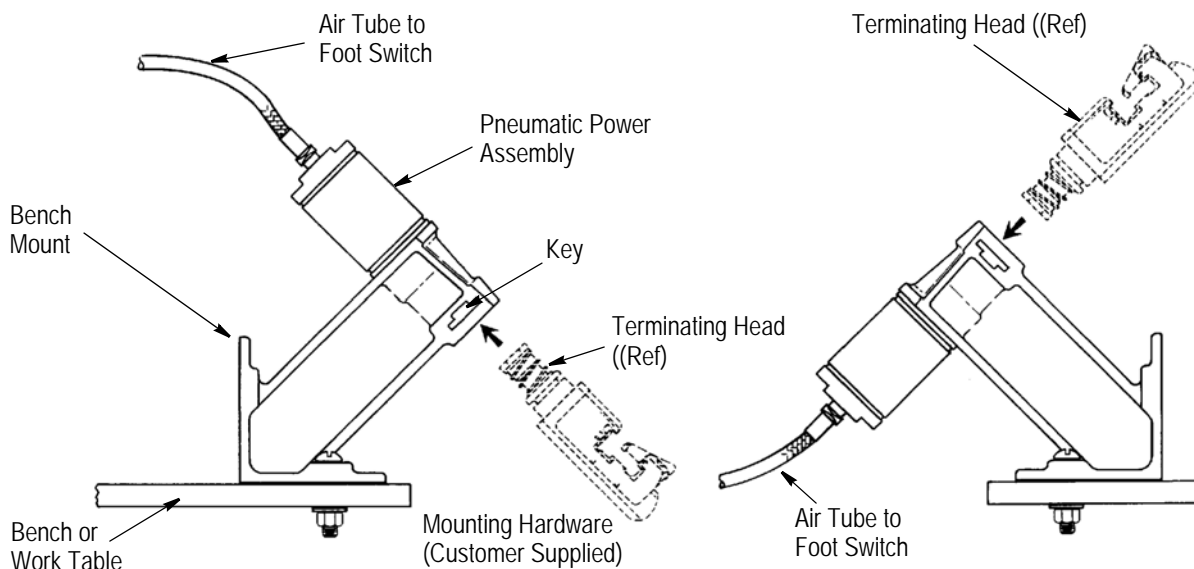

Figure 2

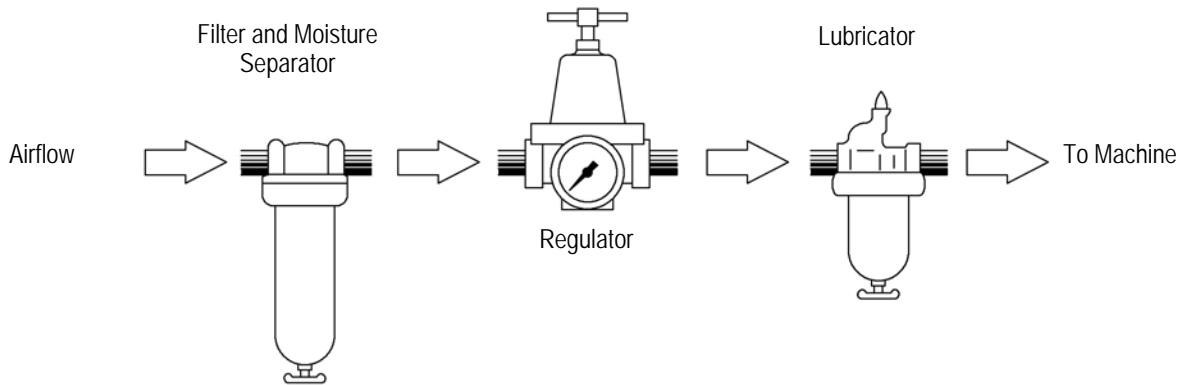

Figure 3

5. INSTALLATION AND REMOVAL OF TERMINATING HEAD OR FEED TRACK ASSEMBLY

1. DISCONNECT the power bench assembly from the air supply.



To avoid personal injury, ALWAYS DISCONNECT the power bench assembly from the air supply when installing or removing the terminating head or feed track assembly.

2. Position the blade tip of a screwdriver between the shoulder of the key and the power assembly body. Gently pry the key out of the keyway.
3. Insert the terminating head or feed track assembly into the head entrance of the power assembly body until it bottoms. See Figure 4.
4. Insert the key completely into the keyway to retain the terminating head or feed track assembly.
5. To remove the terminating head or feed track assembly, disconnect the power bench assembly

from air supply, remove the key, and pull the terminating head or feed track assembly out of the power assembly. Refer to Figure 4



Do not use this tool as a blunt object, a crushing device, or for any purpose other than crimping the proper specified product. Inappropriate use of the tool could result in personal injury or damage to the tool.

6. OPERATION

The following procedure provides only general information concerning crimping. Refer to the instructions packaged with the terminating heads for detailed information including wire stripping dimensions and instructions for positioning terminals in the terminating heads.

1. Insert the connector into the left side of the head.

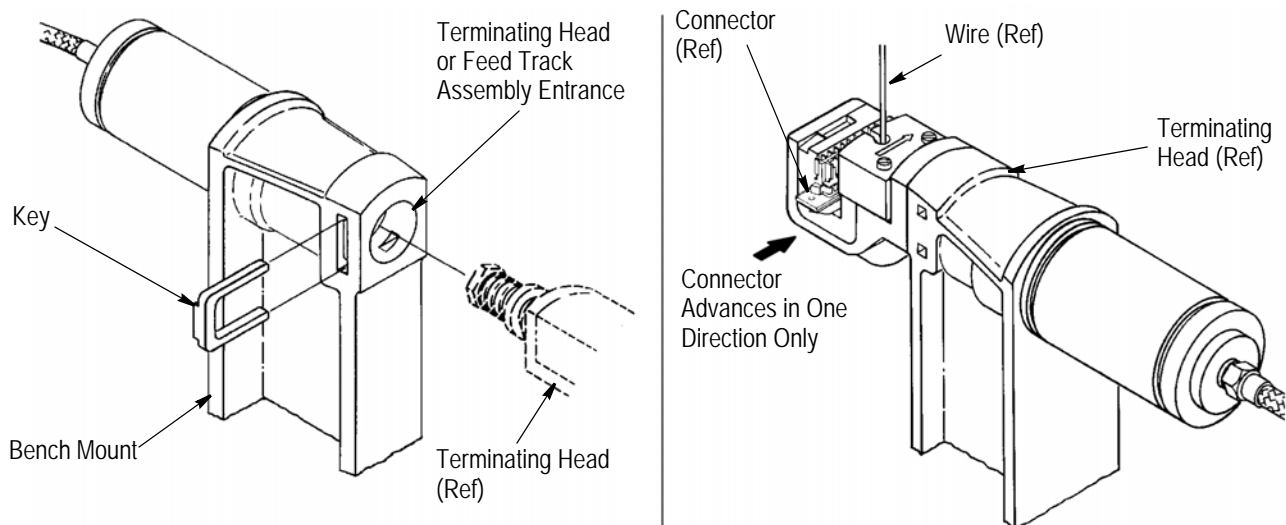

Figure 4

2. Align the contact to be terminated with the wire inserter of the head. Make sure that the locating pawl rests between the connector index ribs.
3. Insert an unstripped wire into the funnel area between the contact and the wire inserter until it bottoms on the tool base.
4. Depress the footswitch and hold it until the wire inserter bottoms.
5. Release the footswitch. The wire inserter will retract and the feed slide will automatically advance the connector to the next contact position.
6. Repeat steps 2 through 5 until all contacts have been terminated.
7. Inspect each termination.

7. MAINTENANCE AND INSPECTION



To avoid personal injury, ALWAYS DISCONNECT the power bench assembly from the air supply when performing maintenance or inspection procedures.

These procedures have been established to ensure the quality and reliability of the power bench assembly. A brief inspection should be made daily by the operator and a more detailed inspection should be performed on a scheduled basis by quality control personnel.

7.1. Daily Maintenance

Each operator of the unit should be made aware of, and responsible for, the following procedures:

1. Remove dust, moisture, and other contaminants with a clean, soft brush, or clean, lint-free cloth. DO NOT use objects that could damage the power bench assembly.
2. Ensure that all components are in place and properly secured.
3. With the terminating head or feed track assembly in place, connect the air supply and actuate the power assembly by depressing and releasing the foot switch to ensure that the mechanisms and plunger move smoothly and freely.

7.2. Periodic Inspection (At Least Once a Month)

Regular inspections should be performed by quality control personnel. A record of quality control inspections should remain with the power bench assembly or with personnel responsible for the assembly. It is recommended that one inspection per month be performed; however, operator training and skill, amount of use, working conditions, and established company standards are all factors to be considered in scheduling inspections.

The inspections should be performed in the following sequence:

1. Remove any accumulated film with a suitable cleaning agent that will not affect plastic material.
2. Make certain that all components are in place and properly secured. Check air tube fittings for leaks.
3. Make a few test terminations and inspect the terminations in accordance with the inspection procedure described in the instructions packaged with the terminating head or feed track assembly.
4. Check for chipped, cracked, worn, or broken areas. If damage is evident, repair is necessary. See Section 8, REPLACEMENT AND REPAIR.

8. REPLACEMENT AND REPAIR

Customer-replaceable parts are listed in Figure 5.

A complete inventory should be stocked and controlled to prevent lost time when replacement of parts is necessary. Parts other than those listed should be replaced by TE to ensure quality and reliability. Order replacement parts through your TE representative, or call 1-800-526-5142, or send a facsimile of your purchase order to 717-986-7605, or write to:

CUSTOMER SERVICE (038-035)
TYCO ELECTRONICS CORPORATION
P0 BOX 3608
HARRISBURG, PA 17105-3608

or

TYCO ELECTRONICS CORPORATION UK LTD
BARTON TORS
BIDEFORD
NORTH DEVON, GREAT BRITAIN

For customer repair service, call 1-800-526-5136.

A basic pneumatic schematic is provided in Figure 6.

9. REVISION SUMMARY

Since the previous release of these instructions, the format was changed.

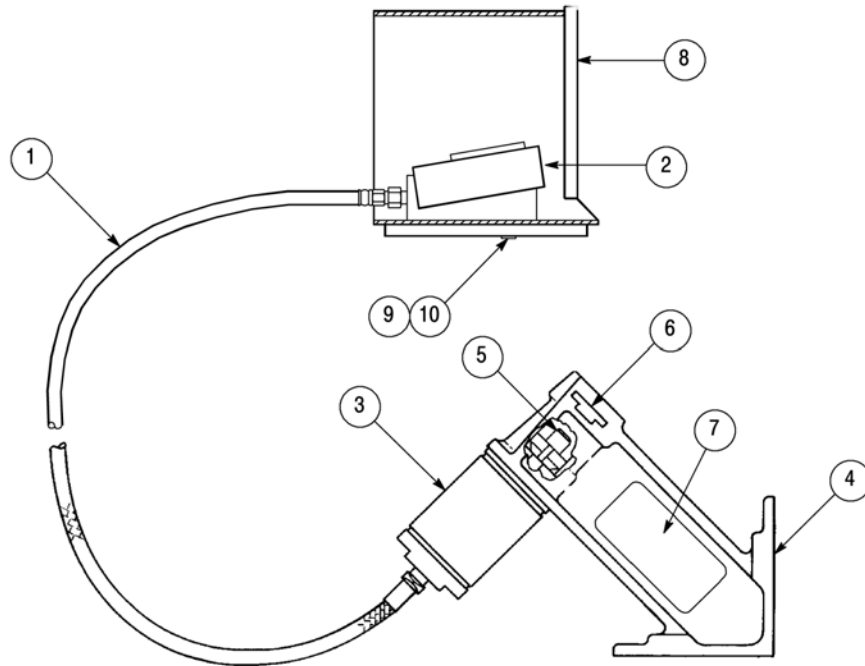

ITEM	PART NUMBER	DESCRIPTION	QTY PER ASSY
1	312622-2	SUBASSEMBLY, Air Tube	2
2	24198-1	AIR VALVE, 3-Way	1
3	313874-1	AIR CYLINDER	1
4	313852-1	BENCH MOUNT	1
5	312141-1	NUT, Cam Adjustment	1
6	312140-1	KEY	1
7	2119907-4	LABEL, CE	1
8	453866-1	GUARD, Foot Switch	1
9	4-23715-1	SCREW, Machine Pan Head, 4-40 x .19 in.	1
10	21060-7	SCREW, Slotted Pan Head, 4-40 x .25 in.	1

Figure 5

Pneumatic Schematic for 58388-1

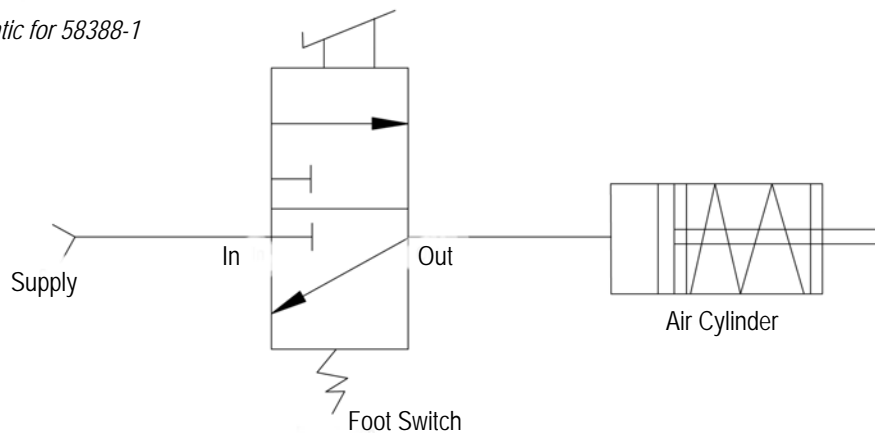

Figure 6



Поставка электронных компонентов

Юридический адрес организации:
198099, г. Санкт-Петербург, ул. Калинина, дом 2, кор. 4, лит А.

Фактический адрес организации:
198099, г. Санкт-Петербург, ул. Калинина, дом 2, кор. 4, лит А.
ИНН 780277764
КПП 780501001

Р/С 40702810422510004035 ФАКБ "АБСОЛЮТ БАНК" (ЗАО) в Санкт-Петербурге К/С 30101810900000000703
БИК 044030703

Телефон: 8 (812) 309-44-11 (многоканальный)

Факс: 8 (812) 309-44-11

Электронная почта: sales@timechips.ru

Сайт: timechips.ru

Информационное письмо

Компания «ТаймЧипс» - одна из наиболее динамично развивающихся компаний в сфере поставок электронных компонентов. Мы поставляем широкую номенклатуру электронных компонентов отечественных и импортных производителей, как напрямую, так и с крупных мировых складов, позволяющих охватить выборочную номенклатуру более 300 брендов, а также специализируемся на поставках дисплеев и является официальным дистрибьютором компании Shenzhen Startek Electronic Technology Co, на территории Российской Федерации.

Наличие собственной логистики позволяет в кратчайшие сроки доставлять товар нашим клиентам. В нашей компании имеется Конструкторский отдел, где наши специалисты проводят технические консультации клиентов, квалифицированную поддержку и помощь российским разработчикам. Осуществляем Поставки импортной продукции под контролем ВП МО РФ, на предприятия Оборонно-промышленного комплекса России. Система менеджмента качества компании соответствует требованиям ГОСТ ISO 9001-2011.

Благодаря нацеленности на результат, мы уверенно занимаем новые позиции на рынке, заинтересовывая Клиента не только актуальными ценами и гибким подходом, но и постоянным вниманием.

Миссия – обеспечение долгосрочного и взаимовыгодного партнерства с клиентами.

Наша цель – Обеспечение клиентам самого широкого ассортимента электронных компонентов и бесперебойности поставок.

Мы - это развитие! Мы задаем темп! Мы разные, но вместе! Мы работаем для вас!

Так же имеем прямые поставки от производителей:

TAI-SAW Пав-компоненты (www.taisaw.com)

TRANSCOM СВЧ-компоненты (www.transcominc.com.tw)

Mini Circuits ВЧ-СВЧ-компоненты (minicircuits.com)

SAMTEC- разъемы (www.samtec.com)

4Star Разъемы РЧ (Даташиты по продукции 4Star, которые Вы сможете загрузить по этой ссылке: <https://yadi.sk/i/tPjnmGGrpmbYj>)

ULNION Преобразователи напряжения (converterdc.com/)

Отличные рекомендации на рынке, уверенность в качестве поставляемой продукции делают нас надежными партнерами для наших клиентов.

«ТаймЧипс» - это:

- Гарантия качества поставляемой продукции;
- Широкий ассортимент;
- Минимальные сроки поставок;
- Техническая поддержка;
- Подбор комплектации;
- Индивидуальный подход;
- Гибкие цены.

Модули, микросхемы, пассивные компоненты, Xilinx (XC), Altera (EP,EPF, EPM) и силовая электроника – это наши ведущие позиции, на поставку которых мы гарантированно дадим Вам самые выгодные предложения!

В структуру компании так же входит конструкторский отдел, который помогает разработчикам и конструкторам в решении следующих задач:

- Оценка стоимости проекта по компонентам;
- Подбор оптимального решения при выборе компонента;
- Подбор аналогов;
- Техническая поддержка;
- Консультации у производителей;
- Поставка прототипов;

С Уважением, Чернов Павел.

Руководитель отдела продаж ООО "ТАЙМЧИПС"

Официальный дистрибьютор Shenzhen Startek Electronic Technology Co.,Ltd в России (USB Display Modules , LED Displays, Serial Modules).

<http://www.timechips.ru/>

<http://lcd-timechips.ru/>

Телефон: +7 (812) 309-44-11 доб. 141

Факс: +7 (812) 309-44-11 доб. 152

Моб. Тел. +7 (905) 232-40-65

Skype: time.chips5

Электронная почта: manager1@timechips.ru
