

A 90-3144

RAW MAT. SPEC. WITH
PART NO. AND AMOUNT REQ'D.

*.068 X .035 DEEP KEYWAY.
.071*

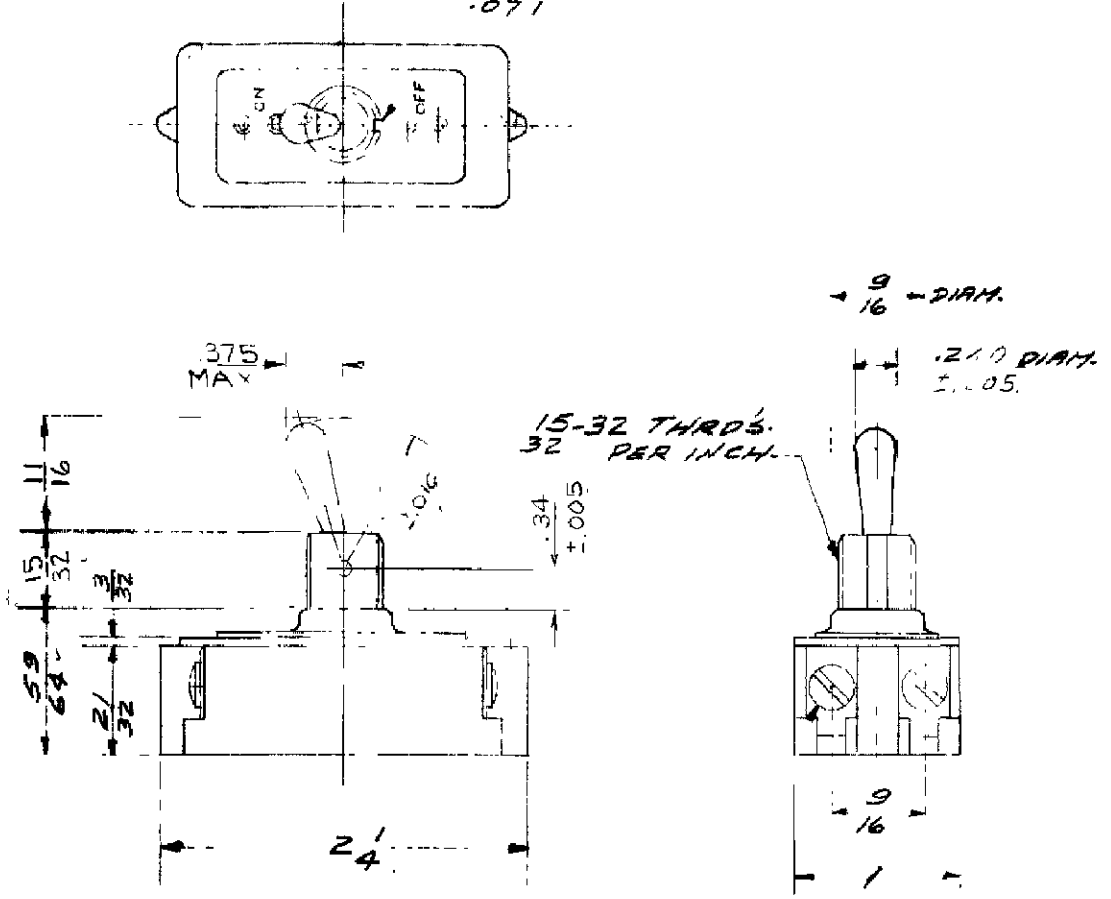

*A-#6-32 BINDING -
HEAD SCREWS 1/4" LONG*

BULLETIN
DIMENSIONS FOR 10 AMP. 250 V. ONE HOLE MTG. TOOL HANDLE SM.

A	G.F.L.	G.G.	2-8 62	DR. R. ARTIN	3-30 -61	FIRST ASSEM. WHERE LISTED A90-3143
B				CHK. L. SOTO 2/31/61		SUP. S. NON-INTERCHANGEABLE
C				APPROV. J.E. BURGESS 4/27		SUP. D BY NON-INTERCHANGEABLE
D						SURFACE COATING
E						STANDARD TOLERANCES 50-275 APPLY TO DIMENSIONS SCALE 1" = 1"
F						ORDER NO.
CUTLER-HAMMER, INC. MILWAUKEE NEW YORK				8 23 LI 57A		A 90-3144

NOTES:

1. SCREWS, WASHER AND HEX NUTS SHIPPED UNASSEMBLED.

$.072^{+.003}_{-.004} \times .035$ DEEP KEYWAY

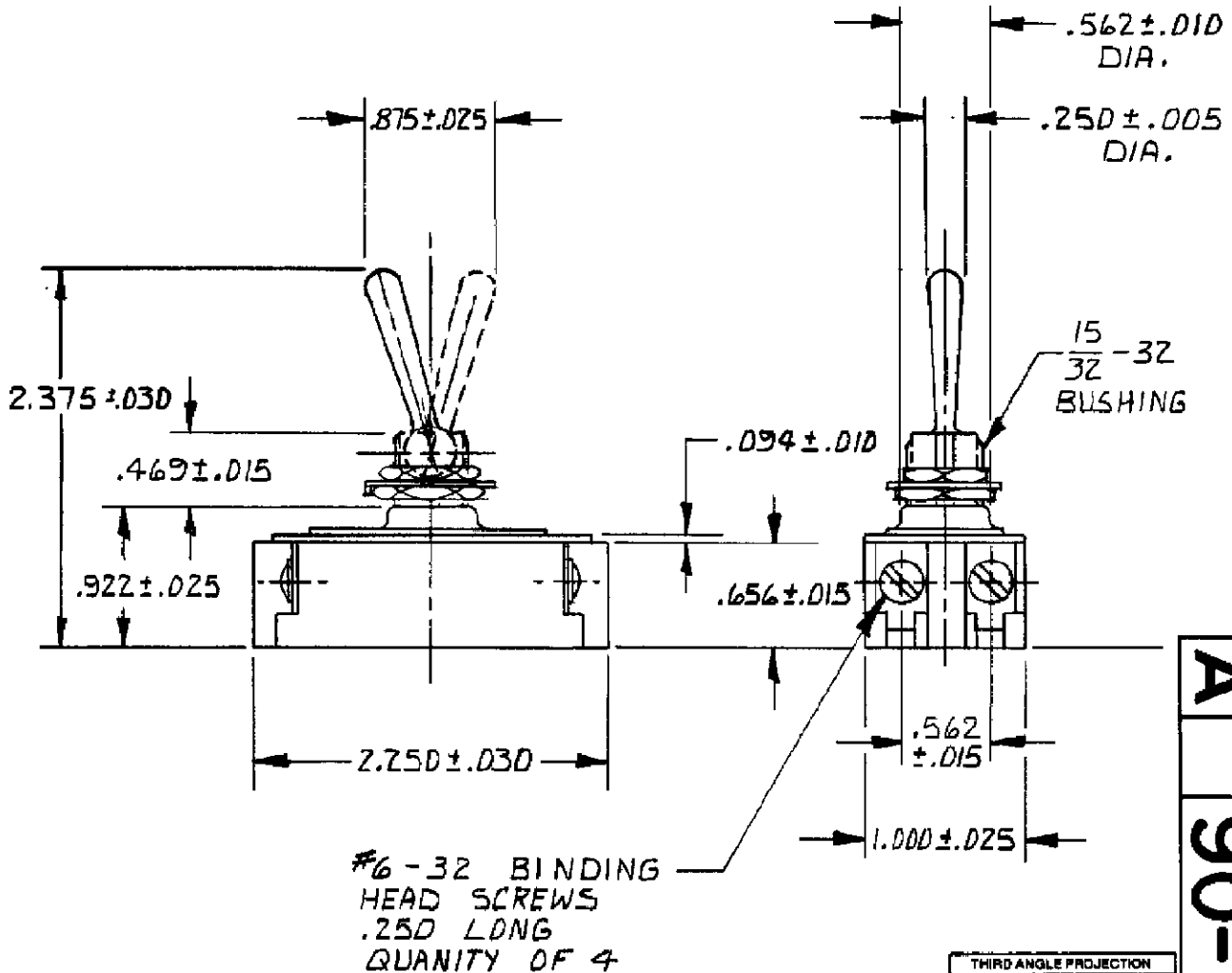
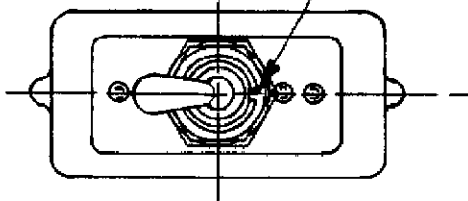

TITLE DIMENSIONS FOR 10-20A TOGGLE WITH LEVER SEAL

ORDER NO. 910DN 76

BASIC SPECS. SUMMARY

A		DR. G. STORY	12/1/84	APP. <i>[Signature]</i> 12/1/84
B		CHK. <i>C. Mardine</i>	12/1/84	FIRST ASSEM. WHERE LISTED
C		Cutler-Hammer F.T.N. Electrical / Electronic Control		

A 90-12054

FORM 80B

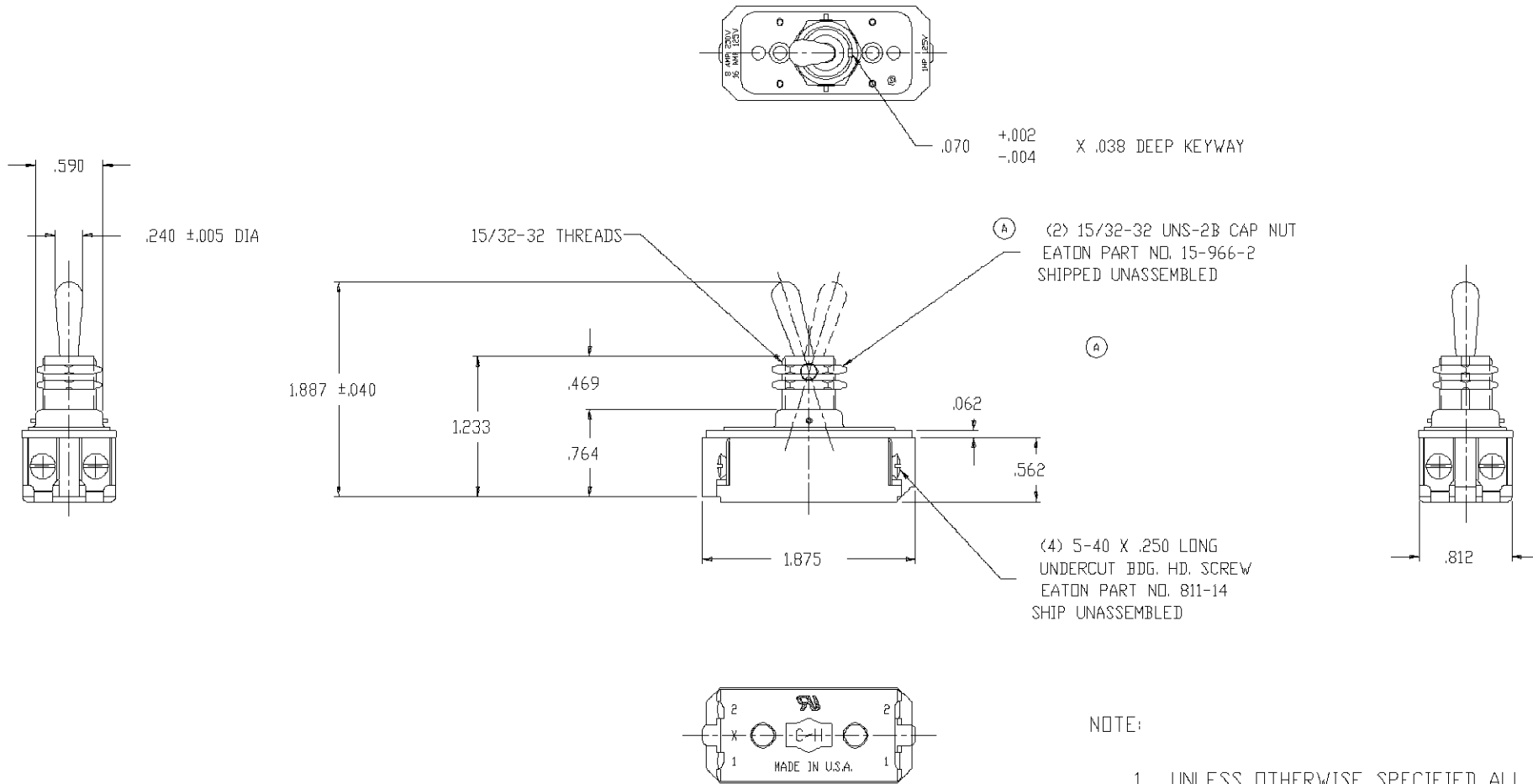

NOTE:

1. UNLESS OTHERWISE SPECIFIED ALL TOLERANCES TO BE $\pm .016$.

ORDER NO. 93719990

A	REMOVED 15-192 NUT NOTE, ADDED "(2)" TO 15-966-2 NUT NOTE.	6/29/94	D				
B		93719990	E				
C			F				



TITLE: DIM DWG FOR 8910K223			
DR.	W. HANSON	2/1/92	SURFACE COATING
CHK.	W. LEONARD	2/3/92	SCALE
APP.	M.R. DUMMER	2/3/92	DO NOT SCALE DRAWING
			FIRST ASSEM. WHERE LISTED 8910K223
			SUP'D BY