

LS1088A

QorIQ LS1088A Data Sheet

Features

- LS1088A contains eight ARM® Cortex®-A53 (32/64 bit) cores with the following capabilities:
 - Speed up to 1.6 GHz
 - Arranged as two clusters of four cores
 - 32 KB L1 instruction cache (ECC protection) and 32 KB L1 data cache (ECC protection)
 - Two 1 MB unified I/D L2 cache (ECC protection), one per Cortex-A53 core cluster
 - NEON™ SIMD coprocessor
 - ARMv8 cryptography extensions
- Hierarchical interconnect fabric:
 - Hardware-managed data coherency
 - Up to 700 MHz operation
- One 32/64-bit DDR4 SDRAM memory controller:
 - ECC and interleaving support
 - Up to 2.1 GT/s
- Datapath acceleration architecture 2.0 (DPAA2) incorporates acceleration for the following functions:
 - Packet parsing, classification, and distribution (WRIOP)
 - Queue management for scheduling, packet sequencing, and congestion management (QMan)
 - Hardware buffer management for buffer allocation and de-allocation (BMan)
 - Cryptography acceleration (SEC)
 - IEEE 1588 support
 - Advanced I/O processor (AIOP)
- Parallel Ethernet interfaces:
 - Up to two RGMII interfaces
- Eight SerDes lanes for high-speed peripheral interfaces:
 - Three PCI Express 3.0 controllers (one supporting x4 operation)
 - One serial ATA (SATA 3.0) controller supporting 6 Gbps
 - Up to two SGMII supporting 2500 Mbps
 - Up to four SGMII supporting 1000 Mbps
 - Up to two XFI (10 GbE) interfaces
 - Up to two QSGMII
 - Supports 1000Base-KX
 - Supports 10GBase-KR
- Additional peripheral interfaces include:
 - One quad serial peripheral interface (QSPI) controller, one serial peripheral interface (SPI) controller
 - Integrated flash controller (IFC) supporting NAND and NOR flash with 28-bit addressing and 16-bit data
 - Two USB 3.0 controllers with integrated PHY
 - Enhanced secure digital host controller supporting SD 3.0, eMMC 4.4, and eMMC 4.5 modes
 - uQE supporting TDM/HDLC
 - Four I2C controllers
 - Two 16550-compliant DUARTs
 - General purpose IO (GPIO), four FlexTimers, and nine watchdog timers
 - Trust architecture
 - Debug support with run control, data acquisition, high-speed trace, and performance/event monitoring
- 780 FC-PBGA package, 23 mm x 23 mm, 0.8 mm pitch

Table of Contents

| | | | |
|---|-----|--|-----|
| 1 Overview..... | 3 | 3.17 I2C interface..... | 144 |
| 2 Pin assignments..... | 3 | 3.18 Integrated Flash Controller..... | 147 |
| 2.1 780 BGA ball layout diagrams..... | 4 | 3.19 JTAG interface..... | 166 |
| 2.2 Pinout list..... | 10 | 3.20 Quad serial peripheral interface (QuadSPI)..... | 169 |
| 3 Electrical characteristics..... | 51 | 3.21 QUICC engine specifications..... | 173 |
| 3.1 Overall DC electrical characteristics..... | 51 | 3.22 Serial peripheral interface (SPI)..... | 179 |
| 3.2 General AC timing specifications..... | 57 | 3.23 Universal serial bus (USB) interface..... | 182 |
| 3.3 Power sequencing..... | 58 | 4 Hardware design considerations..... | 185 |
| 3.4 Power-down requirements..... | 61 | 4.1 Clock ranges..... | 185 |
| 3.5 Power characteristics..... | 61 | 4.2 Power supply design..... | 186 |
| 3.6 Power-on ramp rate..... | 63 | 5 Thermal..... | 187 |
| 3.7 Input clocks..... | 63 | 5.1 Recommended thermal model..... | 188 |
| 3.8 RESET initialization timing specifications..... | 70 | 5.2 Temperature diode..... | 188 |
| 3.9 Battery-backed security monitor interface..... | 71 | 5.3 Thermal management information..... | 188 |
| 3.10 DDR4 SDRAM controller..... | 72 | 6 Package information..... | 191 |
| 3.11 Dual universal asynchronous receiver/transmitter (DUART) interface..... | 77 | 6.1 Package parameters for the FC-PBGA..... | 191 |
| 3.12 Enhanced secure digital host controller (eSDHC)..... | 79 | 6.2 Mechanical dimensions of the FC-PBGA..... | 191 |
| 3.13 Ethernet interface (EMI, RGMII, and IEEE Std 1588)..... | 87 | 7 Security fuse processor..... | 193 |
| 3.14 General purpose input/output (GPIO) interface..... | 97 | 8 Ordering information..... | 193 |
| 3.15 Generic interrupt controller (GIC) interface..... | 101 | 8.1 Part numbering nomenclature..... | 193 |
| 3.16 High-speed serial interfaces (HSSI)..... | 103 | 8.2 Part marking | 194 |
| | | 9 Revision history..... | 195 |

1 Overview

A member of the Layerscape (LS1) series, the LS1088A is a cost-effective, power-efficient, and highly integrated system-on-chip (SoC) device featuring eight extremely power-efficient 64-bit ARM® Cortex®-A53 cores with ECC-protected L1 and L2 cache memories for high reliability, running up to 1.6 GHz.

The LS1088A family of devices can be used for enterprise and service provider routers, Virtual CPE, industrial communications, security appliance and military and aerospace applications.

This figure shows the LS1088A block diagram.



Figure 1. LS1088A block diagram

2 Pin assignments

NOTE: Information given in this section is preliminary and is subject to change.

2.1 780 BGA ball layout diagrams

This figure shows the complete view of the LS1088A BGA ball map diagram. [Figure 3](#), [Figure 4](#), [Figure 5](#), and [Figure 6](#) show quadrant views.



Figure 2. Complete BGA Map for the LS1088A

Pin assignments



Figure 3. Detail A



Figure 4. Detail B

Pin assignments



Figure 5. Detail C



Figure 6. Detail D

2.2 Pinout list

This table provides the pinout listing for the LS1088A by bus. Primary functions are **bolded** in the table.

Table 1. Pinout list by bus

| Signal | Signal description | Package pin number | Pin type | Power supply | Notes |
|-------------------------------------|--------------------------------|--------------------|----------|-------------------|-------|
| DDR SDRAM Memory Interface 1 | | | | | |
| D1_MA00 | Address | V27 | O | G1V _{DD} | 1 |
| D1_MA01 | Address | N27 | O | G1V _{DD} | 1 |
| D1_MA02 | Address | N28 | O | G1V _{DD} | 1 |
| D1_MA03 | Address | M28 | O | G1V _{DD} | 1 |
| D1_MA04 | Address | L28 | O | G1V _{DD} | 1 |
| D1_MA05 | Address | L27 | O | G1V _{DD} | 1 |
| D1_MA06 | Address | K28 | O | G1V _{DD} | 1 |
| D1_MA07 | Address | J27 | O | G1V _{DD} | 1 |
| D1_MA08 | Address | J28 | O | G1V _{DD} | 1 |
| D1_MA09 | Address | G28 | O | G1V _{DD} | 1 |
| D1_MA10 | Address | Y28 | O | G1V _{DD} | 1 |
| D1_MA11 | Address | H28 | O | G1V _{DD} | 1 |
| D1_MA12 | Address | G27 | O | G1V _{DD} | 1 |
| D1_MA13 | Address | AD27 | O | G1V _{DD} | 1 |
| D1_MACT_B | Activate | D28 | O | G1V _{DD} | 1 |
| D1_MALERT_B | Alert | F28 | I | G1V _{DD} | 1, 6 |
| D1_MBA0 | Bank Select | Y27 | O | G1V _{DD} | 1 |
| D1_MBA1 | Bank Select | W28 | O | G1V _{DD} | 1 |
| D1_MBG0 | Bank Group | E27 | O | G1V _{DD} | 1 |
| D1_MBG1 | Bank Group | E28 | O | G1V _{DD} | 1 |
| D1_MCAS_B | Column Address Strobe / MA[15] | AC28 | O | G1V _{DD} | 1 |
| D1_MCK0 | Clock | R28 | O | G1V _{DD} | --- |
| D1_MCK0_B | Clock Complement | R27 | O | G1V _{DD} | --- |
| D1_MCK1 | Clock | T28 | O | G1V _{DD} | --- |
| D1_MCK1_B | Clock Complement | T27 | O | G1V _{DD} | --- |
| D1_MCKE0 | Clock Enable | C28 | O | G1V _{DD} | 1 |
| D1_MCKE1 | Clock Enable | B28 | O | G1V _{DD} | 1 |
| D1_MCS0_B | Chip Select | AB27 | O | G1V _{DD} | 1 |
| D1_MCS1_B | Chip Select | AE28 | O | G1V _{DD} | 1 |
| D1_MCS2_B | Chip Select | AG28 | O | G1V _{DD} | 1 |

Table continues on the next page...

Table 1. Pinout list by bus (continued)

| Signal | Signal description | Package pin number | Pin type | Power supply | Notes |
|-----------|------------------------------|--------------------|----------|-------------------|-------|
| D1_MCS3_B | Chip Select | AF28 | O | G1V _{DD} | 1 |
| D1_MDIC0 | Driver Impedence Calibration | P28 | IO | G1V _{DD} | 3 |
| D1_MDIC1 | Driver Impedence Calibration | U28 | IO | G1V _{DD} | 3 |
| D1_MDM0 | Data Mask | B23 | O | G1V _{DD} | --- |
| D1_MDM1 | Data Mask | H22 | O | G1V _{DD} | --- |
| D1_MDM2 | Data Mask | E25 | O | G1V _{DD} | --- |
| D1_MDM3 | Data Mask | J25 | O | G1V _{DD} | --- |
| D1_MDM4 | Data Mask | V25 | O | G1V _{DD} | --- |
| D1_MDM5 | Data Mask | AD24 | O | G1V _{DD} | --- |
| D1_MDM6 | Data Mask | AC23 | O | G1V _{DD} | --- |
| D1_MDM7 | Data Mask | AH24 | O | G1V _{DD} | --- |
| D1_MDM8 | Data Mask | P24 | O | G1V _{DD} | --- |
| D1_MDQ00 | Data | C22 | IO | G1V _{DD} | --- |
| D1_MDQ01 | Data | A23 | IO | G1V _{DD} | --- |
| D1_MDQ02 | Data | C26 | IO | G1V _{DD} | --- |
| D1_MDQ03 | Data | A27 | IO | G1V _{DD} | --- |
| D1_MDQ04 | Data | B22 | IO | G1V _{DD} | --- |
| D1_MDQ05 | Data | A22 | IO | G1V _{DD} | --- |
| D1_MDQ06 | Data | B25 | IO | G1V _{DD} | --- |
| D1_MDQ07 | Data | A26 | IO | G1V _{DD} | --- |
| D1_MDQ08 | Data | E22 | IO | G1V _{DD} | --- |
| D1_MDQ09 | Data | D22 | IO | G1V _{DD} | --- |
| D1_MDQ10 | Data | F23 | IO | G1V _{DD} | --- |
| D1_MDQ11 | Data | G23 | IO | G1V _{DD} | --- |
| D1_MDQ12 | Data | G22 | IO | G1V _{DD} | --- |
| D1_MDQ13 | Data | F22 | IO | G1V _{DD} | --- |
| D1_MDQ14 | Data | C24 | IO | G1V _{DD} | --- |
| D1_MDQ15 | Data | E23 | IO | G1V _{DD} | --- |
| D1_MDQ16 | Data | D26 | IO | G1V _{DD} | --- |
| D1_MDQ17 | Data | E24 | IO | G1V _{DD} | --- |
| D1_MDQ18 | Data | G24 | IO | G1V _{DD} | --- |
| D1_MDQ19 | Data | H25 | IO | G1V _{DD} | --- |
| D1_MDQ20 | Data | C25 | IO | G1V _{DD} | --- |
| D1_MDQ21 | Data | D25 | IO | G1V _{DD} | --- |
| D1_MDQ22 | Data | G25 | IO | G1V _{DD} | --- |
| D1_MDQ23 | Data | H26 | IO | G1V _{DD} | --- |
| D1_MDQ24 | Data | K23 | IO | G1V _{DD} | --- |
| D1_MDQ25 | Data | J24 | IO | G1V _{DD} | --- |

Table continues on the next page...

Table 1. Pinout list by bus (continued)

| Signal | Signal description | Package pin number | Pin type | Power supply | Notes |
|----------|--------------------|--------------------|----------|-------------------|-------|
| D1_MDQ26 | Data | L24 | IO | G1V _{DD} | --- |
| D1_MDQ27 | Data | M24 | IO | G1V _{DD} | --- |
| D1_MDQ28 | Data | J22 | IO | G1V _{DD} | --- |
| D1_MDQ29 | Data | H23 | IO | G1V _{DD} | --- |
| D1_MDQ30 | Data | K24 | IO | G1V _{DD} | --- |
| D1_MDQ31 | Data | L25 | IO | G1V _{DD} | --- |
| D1_MDQ32 | Data | V24 | IO | G1V _{DD} | --- |
| D1_MDQ33 | Data | U26 | IO | G1V _{DD} | --- |
| D1_MDQ34 | Data | AA26 | IO | G1V _{DD} | --- |
| D1_MDQ35 | Data | W23 | IO | G1V _{DD} | --- |
| D1_MDQ36 | Data | U24 | IO | G1V _{DD} | --- |
| D1_MDQ37 | Data | U25 | IO | G1V _{DD} | --- |
| D1_MDQ38 | Data | W24 | IO | G1V _{DD} | --- |
| D1_MDQ39 | Data | Y25 | IO | G1V _{DD} | --- |
| D1_MDQ40 | Data | AB24 | IO | G1V _{DD} | --- |
| D1_MDQ41 | Data | AB25 | IO | G1V _{DD} | --- |
| D1_MDQ42 | Data | AE25 | IO | G1V _{DD} | --- |
| D1_MDQ43 | Data | AF25 | IO | G1V _{DD} | --- |
| D1_MDQ44 | Data | Y24 | IO | G1V _{DD} | --- |
| D1_MDQ45 | Data | AA25 | IO | G1V _{DD} | --- |
| D1_MDQ46 | Data | AD25 | IO | G1V _{DD} | --- |
| D1_MDQ47 | Data | AE26 | IO | G1V _{DD} | --- |
| D1_MDQ48 | Data | AA22 | IO | G1V _{DD} | --- |
| D1_MDQ49 | Data | AB23 | IO | G1V _{DD} | --- |
| D1_MDQ50 | Data | AC22 | IO | G1V _{DD} | --- |
| D1_MDQ51 | Data | AB22 | IO | G1V _{DD} | --- |
| D1_MDQ52 | Data | Y22 | IO | G1V _{DD} | --- |
| D1_MDQ53 | Data | AA23 | IO | G1V _{DD} | --- |
| D1_MDQ54 | Data | AD22 | IO | G1V _{DD} | --- |
| D1_MDQ55 | Data | AE22 | IO | G1V _{DD} | --- |
| D1_MDQ56 | Data | AH25 | IO | G1V _{DD} | --- |
| D1_MDQ57 | Data | AF24 | IO | G1V _{DD} | --- |
| D1_MDQ58 | Data | AG22 | IO | G1V _{DD} | --- |
| D1_MDQ59 | Data | AF22 | IO | G1V _{DD} | --- |
| D1_MDQ60 | Data | AH26 | IO | G1V _{DD} | --- |
| D1_MDQ61 | Data | AG25 | IO | G1V _{DD} | --- |
| D1_MDQ62 | Data | AF23 | IO | G1V _{DD} | --- |
| D1_MDQ63 | Data | AH22 | IO | G1V _{DD} | --- |

Table continues on the next page...

Table 1. Pinout list by bus (continued)

| Signal | Signal description | Package pin number | Pin type | Power supply | Notes |
|------------------------------------|-----------------------------|--------------------|----------|-------------------|-------|
| D1_MDQS0 | Data Strobe | A25 | IO | G1V _{DD} | --- |
| D1_MDQS0_B | Data Strobe | A24 | IO | G1V _{DD} | --- |
| D1_MDQS1 | Data Strobe | D23 | IO | G1V _{DD} | --- |
| D1_MDQS1_B | Data Strobe | C23 | IO | G1V _{DD} | --- |
| D1_MDQS2 | Data Strobe | F25 | IO | G1V _{DD} | --- |
| D1_MDQS2_B | Data Strobe | F26 | IO | G1V _{DD} | --- |
| D1_MDQS3 | Data Strobe | K26 | IO | G1V _{DD} | --- |
| D1_MDQS3_B | Data Strobe | K25 | IO | G1V _{DD} | --- |
| D1_MDQS4 | Data Strobe | W26 | IO | G1V _{DD} | --- |
| D1_MDQS4_B | Data Strobe | W25 | IO | G1V _{DD} | --- |
| D1_MDQS5 | Data Strobe | AC25 | IO | G1V _{DD} | --- |
| D1_MDQS5_B | Data Strobe | AC26 | IO | G1V _{DD} | --- |
| D1_MDQS6 | Data Strobe | AE23 | IO | G1V _{DD} | --- |
| D1_MDQS6_B | Data Strobe | AD23 | IO | G1V _{DD} | --- |
| D1_MDQS7 | Data Strobe | AH23 | IO | G1V _{DD} | --- |
| D1_MDQS7_B | Data Strobe | AG23 | IO | G1V _{DD} | --- |
| D1_MDQS8 | Data Strobe | P25 | IO | G1V _{DD} | --- |
| D1_MDQS8_B | Data Strobe | P26 | IO | G1V _{DD} | --- |
| D1_MECC0 | Error Correcting Code | M26 | IO | G1V _{DD} | --- |
| D1_MECC1 | Error Correcting Code | N25 | IO | G1V _{DD} | --- |
| D1_MECC2 | Error Correcting Code | T25 | IO | G1V _{DD} | --- |
| D1_MECC3 | Error Correcting Code | T24 | IO | G1V _{DD} | --- |
| D1_MECC4 | Error Correcting Code | M25 | IO | G1V _{DD} | --- |
| D1_MECC5 | Error Correcting Code | N24 | IO | G1V _{DD} | --- |
| D1_MECC6 | Error Correcting Code | R25 | IO | G1V _{DD} | --- |
| D1_MECC7 | Error Correcting Code | R24 | IO | G1V _{DD} | --- |
| D1_MODT0 | On Die Termination | AD28 | O | G1V _{DD} | 1 |
| D1_MODT1 | On Die Termination | AF27 | O | G1V _{DD} | 1 |
| D1_MPAR | Address Parity Out | V28 | O | G1V _{DD} | 1 |
| D1_MRAS_B | Row Address Strobe / MA[16] | AA28 | O | G1V _{DD} | 1 |
| D1_MWE_B | Write Enable / MA[14] | AB28 | O | G1V _{DD} | 1 |
| Integrated Flash Controller | | | | | |
| IFC_A00/GPIO1_16/ QSPI_A_CS0 | IFC Address | D8 | O | OV _{DD} | 1, 5 |
| IFC_A01/GPIO1_17/ QSPI_A_CS1 | IFC Address | C8 | O | OV _{DD} | 1, 5 |
| IFC_A02/GPIO1_18/ QSPI_A_SCK | IFC Address | C9 | O | OV _{DD} | 1, 5 |

Table continues on the next page...

Table 1. Pinout list by bus (continued)

| Signal | Signal description | Package pin number | Pin type | Power supply | Notes |
|---|--------------------|--------------------|----------|------------------|-------|
| IFC_A03/GPIO1_19/ QSPI_B_CS0 | IFC Address | D10 | O | OV _{DD} | 1, 5 |
| IFC_A04/GPIO1_20/ QSPI_B_CS1 | IFC Address | C10 | O | OV _{DD} | 1, 5 |
| IFC_A05/GPIO1_21/ QSPI_B_SCK/cfg_dram_type | IFC Address | C11 | O | OV _{DD} | 1, 4 |
| IFC_A06/GPIO2_00/ IFC_WP1_B/QSPI_A_DATA0 | IFC Address | D11 | O | OV _{DD} | 1 |
| IFC_A07/GPIO2_01/ IFC_WP2_B/QSPI_A_DATA1 | IFC Address | C12 | O | OV _{DD} | 1 |
| IFC_A08/GPIO2_02/ IFC_WP3_B/QSPI_A_DATA2 | IFC Address | D13 | O | OV _{DD} | 1 |
| IFC_A09/GPIO2_03/ IFC_RB2_B/IFC_CS_B4/ QSPI_A_DATA3 | IFC Address | C13 | O | OV _{DD} | 1 |
| IFC_A10/GPIO2_04/ IFC_RB3_B/IFC_CS_B5/ QSPI_A_DQS | IFC Address | D14 | O | OV _{DD} | 1 |
| IFC_A11/GPIO2_05/ IFC_CS_B6/QSPI_B_DQS | IFC Address | C14 | O | OV _{DD} | 1 |
| IFC_AD00/GPIO1_00/ cfg_gpinput0 | IFC Address / Data | B12 | IO | OV _{DD} | 4, 9 |
| IFC_AD01/GPIO1_01/ cfg_gpinput1 | IFC Address / Data | A11 | IO | OV _{DD} | 4, 9 |
| IFC_AD02/GPIO1_02/ cfg_gpinput2 | IFC Address / Data | B11 | IO | OV _{DD} | 4, 9 |
| IFC_AD03/GPIO1_03/ cfg_gpinput3 | IFC Address / Data | A10 | IO | OV _{DD} | 4, 9 |
| IFC_AD04/GPIO1_04/ cfg_gpinput4 | IFC Address / Data | A9 | IO | OV _{DD} | 4, 9 |
| IFC_AD05/GPIO1_05/ cfg_gpinput5 | IFC Address / Data | B9 | IO | OV _{DD} | 4, 9 |
| IFC_AD06/GPIO1_06/ cfg_gpinput6 | IFC Address / Data | A8 | IO | OV _{DD} | 4, 9 |
| IFC_AD07/GPIO1_07/ cfg_gpinput7 | IFC Address / Data | B8 | IO | OV _{DD} | 4, 9 |
| IFC_AD08/GPIO1_08/ cfg_rcw_src1 | IFC Address / Data | A12 | IO | OV _{DD} | 4, 9 |
| IFC_AD09/GPIO1_09/ cfg_rcw_src2 | IFC Address / Data | A13 | IO | OV _{DD} | 4, 9 |
| IFC_AD10/GPIO1_10/ cfg_rcw_src3 | IFC Address / Data | B14 | IO | OV _{DD} | 4, 9 |
| IFC_AD11/GPIO1_11/ cfg_rcw_src4 | IFC Address / Data | A14 | IO | OV _{DD} | 4, 9 |

Table continues on the next page...

Table 1. Pinout list by bus (continued)

| Signal | Signal description | Package pin number | Pin type | Power supply | Notes |
|--|---|--------------------|----------|------------------|-------|
| IFC_AD12 /GPIO1_12/ cfg_rcw_src5 | IFC Address / Data | B15 | IO | OV _{DD} | 4, 9 |
| IFC_AD13 /GPIO1_13/ cfg_rcw_src6 | IFC Address / Data | A15 | IO | OV _{DD} | 4, 9 |
| IFC_AD14 /GPIO1_14/ cfg_rcw_src7 | IFC Address / Data | A16 | IO | OV _{DD} | 4, 9 |
| IFC_AD15 /GPIO1_15/ cfg_rcw_src8 | IFC Address / Data | A17 | IO | OV _{DD} | 4, 9 |
| IFC_ALE /GPIO1_24 | IFC Address Latch Enable | A18 | O | OV _{DD} | 1, 5 |
| IFC_BCTL /GPIO2_12 | IFC Buffer control | E15 | O | OV _{DD} | 1 |
| IFC_CLE /GPIO1_25/ cfg_rcw_src0 | IFC NAND Command Latch Enable / Write Enable 1 / NOR Address active-low Valid | C19 | O | OV _{DD} | 1, 4 |
| IFC_CLK0 /GPIO2_17 | IFC Clock | A20 | O | OV _{DD} | 1 |
| IFC_CLK1 /GPIO2_18 | IFC Clock | B20 | O | OV _{DD} | 1 |
| IFC_CS0_B /GPIO2_08 | IFC Chip Select | C17 | O | OV _{DD} | 1, 6 |
| IFC_CS1_B /GPIO2_09 | IFC Chip Select | A19 | O | OV _{DD} | 1, 6 |
| IFC_CS2_B /GPIO2_10 | IFC Chip Select | D20 | O | OV _{DD} | 1, 6 |
| IFC_CS3_B /GPIO2_11/ QSPI_B_DATA3/ QSPI_A_DATA7 | IFC Chip Select | C20 | O | OV _{DD} | 1, 6 |
| IFC_CS_B4/ IFC_A09 / GPIO2_03/IFC_RB2_B/ QSPI_A_DATA3 | IFC Chip Select | C13 | O | OV _{DD} | 1 |
| IFC_CS_B5/ IFC_A10 / GPIO2_04/IFC_RB3_B/ QSPI_A_DQS | IFC Chip Select | D14 | O | OV _{DD} | 1 |
| IFC_CS_B6/ IFC_A11 / GPIO2_05/QSPI_B_DQS | IFC Chip Select | C14 | O | OV _{DD} | 1 |
| IFC_NDDQS /GPIO2_13 | IFC DQS Strobe | B17 | IO | OV _{DD} | 9 |
| IFC_NDWE_B /GPIO2_19 | IFC NAND Write Enable / NAND DDR Clock | E16 | O | OV _{DD} | 1 |
| IFC_OE_B /GPIO1_26/ cfg_eng_use1 | IFC Output Enable | C18 | O | OV _{DD} | 1, 5 |
| IFC_PAR0 /GPIO2_06/ QSPI_B_DATA0/ QSPI_A_DATA4 | IFC Address & Data Parity | B18 | IO | OV _{DD} | 9 |
| IFC_PAR1 /GPIO2_07/ QSPI_B_DATA1/ QSPI_A_DATA5 | IFC Address & Data Parity | D17 | IO | OV _{DD} | 9 |
| IFC_PERR_B /GPIO2_16/ QSPI_B_DATA2/ QSPI_A_DATA6 | IFC Parity Error | E17 | I | OV _{DD} | 1 |
| IFC_RB0_B /GPIO2_14 | IFC Ready/Busy CS0 | C16 | I | OV _{DD} | 1, 6 |

Table continues on the next page...

Table 1. Pinout list by bus (continued)

| Signal | Signal description | Package pin number | Pin type | Power supply | Notes |
|---|-------------------------------------|--------------------|----------|------------------|----------|
| IFC_RB1_B/GPIO2_15 | IFC Ready/Busy CS1 | D16 | I | OV _{DD} | 1, 6 |
| IFC_RB2_B/IFC_A09/ GPIO2_03/IFC_CS_B4/ QSPI_A_DATA3 | IFC Ready/Busy CS 2 | C13 | I | OV _{DD} | 1 |
| IFC_RB3_B/IFC_A10/ GPIO2_04/IFC_CS_B5/ QSPI_A_DQS | IFC Ready/Busy CS 3 | D14 | I | OV _{DD} | 1 |
| IFC_TE/GPIO1_23/cfg_ifc_te | IFC External Transceiver Enable | E14 | O | OV _{DD} | 1, 4 |
| IFC_WE0_B/GPIO1_22/ cfg_eng_use0 | IFC Write Enable 0 / Start of Frame | C15 | O | OV _{DD} | 1, 4, 19 |
| IFC_WP0_B/GPIO1_27/ cfg_eng_use2 | IFC Write Protect | D19 | O | OV _{DD} | 1, 5 |
| IFC_WP1_B/IFC_A06/ GPIO2_00/QSPI_A_DATA0 | IFC Write Protect | D11 | O | OV _{DD} | 1 |
| IFC_WP2_B/IFC_A07/ GPIO2_01/QSPI_A_DATA1 | IFC Write Protect | C12 | O | OV _{DD} | 1 |
| IFC_WP3_B/IFC_A08/ GPIO2_02/QSPI_A_DATA2 | IFC Write Protect | D13 | O | OV _{DD} | 1 |
| DUART1 | | | | | |
| UART1_CTS_B/GPIO3_10/ UART3_SIN | Clear To Send | J1 | I | DV _{DD} | 1 |
| UART1_RTS_B/GPIO3_08/ UART3_SOUT | Ready to Send | J2 | O | DV _{DD} | 1 |
| UART1_SIN | Receive Data | H2 | I | DV _{DD} | 1 |
| UART1_SOUT | Transmit Data | H1 | O | DV _{DD} | 1 |
| DUART2 | | | | | |
| UART2_CTS_B/GPIO3_11/ UART4_SIN | Clear To Send | M2 | I | DV _{DD} | 1 |
| UART2_RTS_B/GPIO3_09/ UART4_SOUT | Ready to Send | L1 | O | DV _{DD} | 1 |
| UART2_SIN/GPIO3_07 | Receive Data | K1 | I | DV _{DD} | 1 |
| UART2_SOUT/GPIO3_06 | Transmit Data | L2 | O | DV _{DD} | 1 |
| DUART3 and 4 | | | | | |
| UART3_SIN/UART1_CTS_B/ GPIO3_10 | Receive Data | J1 | I | DV _{DD} | 1 |
| UART3_SOUT/ UART1_RTS_B/GPIO3_08 | Transmit Data | J2 | O | DV _{DD} | 1 |
| UART4_SIN/UART2_CTS_B/ GPIO3_11 | Receive Data | M2 | I | DV _{DD} | 1 |
| UART4_SOUT/ UART2_RTS_B/GPIO3_09 | Transmit Data | L1 | O | DV _{DD} | 1 |
| I2C1 | | | | | |

Table continues on the next page...

Table 1. Pinout list by bus (continued)

| Signal | Signal description | Package pin number | Pin type | Power supply | Notes |
|---|---------------------|--------------------|----------|------------------|-------|
| IIC1_SCL | Serial Clock | N1 | IO | DV _{DD} | 7, 8 |
| IIC1_SDA | Serial Data | M1 | IO | DV _{DD} | 7, 8 |
| I2C2 | | | | | |
| IIC2_SCL/GPIO3_12/ SDHC_CD_B/CLK9/BRGO2 | Serial Clock | K3 | IO | DV _{DD} | 7, 8 |
| IIC2_SDA/GPIO3_13/ SDHC_WP/CLK10/BRGO3 | Serial Data | L3 | IO | DV _{DD} | 7, 8 |
| I2C3 and 4 | | | | | |
| IIC3_SCL/GPIO4_28/EVT5_B/ USB2_DRVVBUS/BRGO4/ CLK11 | Serial Clock | L4 | IO | DV _{DD} | 7, 8 |
| IIC3_SDA/GPIO4_29/EVT6_B/ USB2_PWRFAULT/BRGO1/ CLK12_CLK8 | Serial Data | M4 | IO | DV _{DD} | 7, 8 |
| IIC4_SCL/GPIO4_30/EVT7_B/ TDMA_RQ/UC1_CDB_RXER | Serial Clock | M3 | IO | DV _{DD} | 7, 8 |
| IIC4_SDA/GPIO4_31/EVT8_B/ TDMB_RQ/UC3_CDB_RXER | Serial Data | N3 | IO | DV _{DD} | 7, 8 |
| SPI Interface | | | | | |
| SPI_PCS0/GPIO3_17/ SDHC_DAT4/SDHC_VS | SPI Chip Select | U1 | IO | OV _{DD} | --- |
| SPI_PCS1/GPIO3_18/ SDHC_DAT5/ SDHC_CMD_DIR | SPI Chip Select | R3 | O | OV _{DD} | 1 |
| SPI_PCS2/GPIO3_19/ SDHC_DAT6/ SDHC_DAT0_DIR | SPI Chip Select | T3 | O | OV _{DD} | 1 |
| SPI_PCS3/GPIO3_20/ SDHC_DAT7/ SDHC_DAT123_DIR | SPI Chip Select | V1 | O | OV _{DD} | 1 |
| SPI_SCK/GPIO3_16/ SDHC_GATE_IN | SPI Clock | U2 | IO | OV _{DD} | --- |
| SPI_SIN/GPIO3_15/ SDHC_CLK_SYNC_IN | Master In Slave Out | U3 | I | OV _{DD} | 1 |
| SPI_SOUT/GPIO3_14/ SDHC_CLK_SYNC_OUT | Master Out Slave In | V3 | O | OV _{DD} | 1 |
| eSDHC | | | | | |
| SDHC_CD_B/IIC2_SCL/ GPIO3_12/CLK9/BRGO2 | Command | K3 | I | DV _{DD} | 1 |
| SDHC_CLK/GPIO3_26 | Host to Card Clock | P3 | O | EV _{DD} | 1 |
| SDHC_CLK_SYNC_IN/ SPI_SIN/GPIO3_15 | IN | U3 | I | OV _{DD} | 1 |
| SDHC_CLK_SYNC_OUT/ SPI_SOUT/GPIO3_14 | OUT | V3 | O | OV _{DD} | 1 |

Table continues on the next page...

Table 1. Pinout list by bus (continued)

| Signal | Signal description | Package pin number | Pin type | Power supply | Notes |
|---|--------------------|--------------------|----------|------------------|-------|
| SDHC_CMD /GPIO3_21 | Command/Response | P2 | IO | EV _{DD} | 6 |
| SDHC_CMD_DIR/ SPI_PCS1 / GPIO3_18/SDHC_DAT5 | DIR | R3 | O | OV _{DD} | 1 |
| SDHC_DAT0 /GPIO3_22 | Data | P1 | IO | EV _{DD} | 6 |
| SDHC_DAT0_DIR/ SPI_PCS2 / GPIO3_19/SDHC_DAT6 | DIR | T3 | O | OV _{DD} | 1 |
| SDHC_DAT1 /GPIO3_23 | Data | R2 | IO | EV _{DD} | 6 |
| SDHC_DAT123_DIR/ SPI_PCS3 /GPIO3_20/ SDHC_DAT7 | DIR | V1 | O | OV _{DD} | 1 |
| SDHC_DAT2 /GPIO3_24 | Data | R1 | IO | EV _{DD} | 6 |
| SDHC_DAT3 /GPIO3_25 | Data | T1 | IO | EV _{DD} | 6 |
| SDHC_DAT4/ SPI_PCS0 / GPIO3_17/SDHC_VS | Data | U1 | IO | OV _{DD} | --- |
| SDHC_DAT5/ SPI_PCS1 / GPIO3_18/SDHC_CMD_DIR | Data | R3 | IO | OV _{DD} | --- |
| SDHC_DAT6/ SPI_PCS2 / GPIO3_19/SDHC_DAT0_DIR | Data | T3 | IO | OV _{DD} | --- |
| SDHC_DAT7/ SPI_PCS3 / GPIO3_20/ SDHC_DAT123_DIR | Data | V1 | IO | OV _{DD} | --- |
| SDHC_GATE_IN/ SPI_SCK / GPIO3_16 | IN | U2 | I | OV _{DD} | 1 |
| SDHC_VS/ SPI_PCS0 / GPIO3_17/SDHC_DAT4 | VS | U1 | O | OV _{DD} | 1 |
| SDHC_WP/ IIC2_SDA / GPIO3_13/CLK10/BRGO3 | Write Protect | L3 | I | DV _{DD} | 1 |
| Interrupt Controller | | | | | |
| EVT9_B /GPIO4_10 | Interrupt Output | G7 | IO | OV _{DD} | 7, 9 |
| IRQ00 | External Interrupt | F11 | I | OV _{DD} | 1 |
| IRQ01 | External Interrupt | F15 | I | OV _{DD} | 1 |
| IRQ02 | External Interrupt | H7 | I | OV _{DD} | 1 |
| IRQ03 /GPIO3_27/ TDMB_TSYNC/ UC3_RTSM_TXEN | External Interrupt | J3 | I | DV _{DD} | 1 |
| IRQ04 /GPIO3_28/ TDMA_RXD/UC1_RXD7/ TDMA_TXD | External Interrupt | J4 | I | DV _{DD} | 1 |
| IRQ05 /GPIO3_29/ TDMA_RSYNC/ UC1_CTSB_RXDV | External Interrupt | J5 | I | DV _{DD} | 1 |
| IRQ06 /GPIO4_04/ TDMA_RXD_EXC/ TDMA_TXD/UC1_TXD7 | External Interrupt | K5 | I | DV _{DD} | 1 |

Table continues on the next page...

Table 1. Pinout list by bus (continued)

| Signal | Signal description | Package pin number | Pin type | Power supply | Notes |
|---|---|--------------------|----------|-----------------------|---------|
| IRQ07/GPIO4_05/ TDMA_TSYNC/ UC1_RTSB_TXEN | External Interrupt | L5 | I | DV _{DD} | 1 |
| IRQ08/GPIO4_06/ TDMB_RXD/UC3_RXD7/ TDMB_TXD | External Interrupt | M5 | I | DV _{DD} | 1 |
| IRQ09/GPIO4_07/ TDMB_RSYNC/ UC3_CTSB_RXDV | External Interrupt | N5 | I | DV _{DD} | 1 |
| IRQ10/GPIO4_08/ TDMB_RXD_EXC/ TDMB_TXD/UC3_TXD7 | External Interrupt | P4 | I | DV _{DD} | 1 |
| IRQ11/GPIO4_09 | External Interrupt | W3 | I | LV _{DD} | 1 |
| Debug | | | | | |
| ASLEEP/GPIO1_28/ cfg_soc_use | Asleep | E9 | O | OV _{DD} | 1, 4 |
| CKSTP_OUT_B | Checkstop Out | G15 | O | OV _{DD} | 1, 6, 7 |
| CLK_OUT | Clock Out | G16 | O | OV _{DD} | 2 |
| EVT0_B | Event 0 | E10 | IO | OV _{DD} | 9 |
| EVT1_B | Event 1 | E13 | IO | OV _{DD} | 9 |
| EVT2_B | Event 2 | E8 | IO | OV _{DD} | 9 |
| EVT3_B | Event 3 | E12 | IO | OV _{DD} | 9 |
| EVT4_B | Event 4 | E11 | IO | OV _{DD} | 9 |
| EVT5_B/IIC3_SCL/GPIO4_28/ USB2_DRVVBUS/BRGO4/ CLK11 | Event 5 | L4 | IO | DV _{DD} | --- |
| EVT6_B/IIC3_SDA/GPIO4_29/ USB2_PWRFAULT/BRGO1/ CLK12_CLK8 | Event 6 | M4 | IO | DV _{DD} | --- |
| EVT7_B/IIC4_SCL/GPIO4_30/ TDMA_RQ/UC1_CDB_RXER | Event 7 | M3 | IO | DV _{DD} | --- |
| EVT8_B/IIC4_SDA/GPIO4_31/ TDMB_RQ/UC3_CDB_RXER | Event 8 | N3 | IO | DV _{DD} | --- |
| Trust | | | | | |
| TA_BB_TMP_DETECT_B | Battery Backed Tamper Detect | H12 | I | TA_BB_V _{DD} | --- |
| TA_TMP_DETECT_B | Tamper Detect | H20 | I | OV _{DD} | --- |
| System Control | | | | | |
| HRESET_B | Hard Reset | F8 | IO | OV _{DD} | 6, 7 |
| PORESET_B | Power On Reset | F9 | I | OV _{DD} | --- |
| RESET_REQ_B | Reset Request (POR or Hard) | F10 | O | OV _{DD} | 1, 5 |
| Clocking | | | | | |
| DIFF_SYSCLK | Single Source System Clock Differential (positive) | AA13 | I | SV _{DD} | 20 |

Table continues on the next page...

Table 1. Pinout list by bus (continued)

| Signal | Signal description | Package pin number | Pin type | Power supply | Notes |
|-----------------------|--|--------------------|----------|------------------|-------|
| DIFF_SYSCLK_B | Single Source System Clock Differential (negative) | AB13 | I | SV _{DD} | 20 |
| RTC/GPIO3_30 | Real Time Clock | F17 | I | OV _{DD} | 1 |
| SYSCLK | System Clock | G14 | I | OV _{DD} | --- |
| DDR Clocking | | | | | |
| DDRCLK | DDR Controller Clock | J20 | I | OV _{DD} | --- |
| DFT | | | | | |
| JTAG_BSR_VSEL | Reserved | J19 | I | OV _{DD} | 15 |
| SCAN_MODE_B | Reserved | H19 | I | OV _{DD} | 10 |
| TBSCAN_EN_B | Test Boundary Scan Enable | F19 | I | OV _{DD} | 6 |
| TEST_SEL_B | Reserved | F20 | I | OV _{DD} | 10 |
| JTAG | | | | | |
| TCK | Test Clock | E18 | I | OV _{DD} | --- |
| TDI | Test Data In | G17 | I | OV _{DD} | 9 |
| TDO | Test Data Out | E20 | O | OV _{DD} | 2 |
| TMS | Test Mode Select | G18 | I | OV _{DD} | 9 |
| TRST_B | Test Reset | E19 | I | OV _{DD} | 9 |
| Analog Signals | | | | | |
| D1_TPA | Reserved | F21 | IO | | 12 |
| FA_ANALOG_G_V | Reserved | AG21 | IO | | 15 |
| FA_ANALOG_PIN | Reserved | AD21 | IO | | 15 |
| TD1_ANODE | Thermal diode anode | J13 | IO | | 17 |
| TD1_CATHODE | Thermal diode cathode | H13 | IO | | 17 |
| TH_TPA | Reserved | H8 | - | - | 12 |
| SerDes 1 | | | | | |
| SD1_IMP_CAL_RX | SerDes Receive Impedance Calibration | Y11 | I | SV _{DD} | 11 |
| SD1_IMP_CAL_TX | SerDes Transmit Impedance Calibration | AA6 | I | XV _{DD} | 16 |
| SD1_PLL1_TPA | SerDes PLL 1 Test Point Analog | AF12 | O | AVDD_SD1_PLL1 | 12 |
| SD1_PLL1_TPD | SerDes Test Point Digital | AF13 | O | XV _{DD} | 12 |
| SD1_PLL2_TPA | SerDes PLL 2 Test Point Analog | AF5 | O | AVDD_SD1_PLL2 | 12 |
| SD1_PLL2_TPD | SerDes Test Point Digital | AB5 | O | XV _{DD} | 12 |
| SD1_REF_CLK1_N | SerDes PLL 1 Reference Clock Complement | AH13 | I | SV _{DD} | --- |
| SD1_REF_CLK1_P | SerDes PLL 1 Reference Clock | AG13 | I | SV _{DD} | --- |
| SD1_REF_CLK2_N | SerDes PLL 2 Reference Clock Complement | AB8 | I | SV _{DD} | --- |

Table continues on the next page...

Table 1. Pinout list by bus (continued)

| Signal | Signal description | Package pin number | Pin type | Power supply | Notes |
|-----------------|---------------------------------------|--------------------|----------|------------------|-------|
| SD1_REF_CLK2_P | SerDes PLL 2 Reference Clock | AA8 | I | SV _{DD} | --- |
| SD1_RX0_N | SerDes Receive Data (negative) | AH6 | I | SV _{DD} | --- |
| SD1_RX0_P | SerDes Receive Data (positive) | AG6 | I | SV _{DD} | --- |
| SD1_RX1_N | SerDes Receive Data (negative) | AH8 | I | SV _{DD} | --- |
| SD1_RX1_P | SerDes Receive Data (positive) | AG8 | I | SV _{DD} | --- |
| SD1_RX2_N | SerDes Receive Data (negative) | AH10 | I | SV _{DD} | --- |
| SD1_RX2_P | SerDes Receive Data (positive) | AG10 | I | SV _{DD} | --- |
| SD1_RX3_N | SerDes Receive Data (negative) | AH11 | I | SV _{DD} | --- |
| SD1_RX3_P | SerDes Receive Data (positive) | AG11 | I | SV _{DD} | --- |
| SD1_TX0_N | SerDes Transmit Data (negative) | AE6 | O | XV _{DD} | --- |
| SD1_TX0_P | SerDes Transmit Data (positive) | AD6 | O | XV _{DD} | --- |
| SD1_TX1_N | SerDes Transmit Data (negative) | AE8 | O | XV _{DD} | --- |
| SD1_TX1_P | SerDes Transmit Data (positive) | AD8 | O | XV _{DD} | --- |
| SD1_TX2_N | SerDes Transmit Data (negative) | AE10 | O | XV _{DD} | --- |
| SD1_TX2_P | SerDes Transmit Data (positive) | AD10 | O | XV _{DD} | --- |
| SD1_TX3_N | SerDes Transmit Data (negative) | AE11 | O | XV _{DD} | --- |
| SD1_TX3_P | SerDes Transmit Data (positive) | AD11 | O | XV _{DD} | --- |
| SerDes 2 | | | | | |
| SD2_IMP_CAL_RX | SerDes Receive Impedance Calibration | Y12 | I | SV _{DD} | 11 |
| SD2_IMP_CAL_TX | SerDes Transmit Impedance Calibration | Y20 | I | XV _{DD} | 16 |
| SD2_PLL1_TPA | SerDes PLL 1 Test Point Analog | AF14 | O | AVDD_SD2_PLL1 | 12 |
| SD2_PLL1_TPD | SerDes Test Point Digital | AC13 | O | XV _{DD} | 12 |
| SD2_PLL2_TPA | SerDes PLL 2 Test Point Analog | AF20 | O | AVDD_SD2_PLL2 | 12 |
| SD2_PLL2_TPD | SerDes Test Point Digital | AA20 | O | XV _{DD} | 12 |

Table continues on the next page...

Table 1. Pinout list by bus (continued)

| Signal | Signal description | Package pin number | Pin type | Power supply | Notes |
|------------------|---|--------------------|----------|------------------|-------|
| SD2_REF_CLK1_N | SerDes PLL 1 Reference Clock Complement | AE13 | I | SV _{DD} | --- |
| SD2_REF_CLK1_P | SerDes PLL 1 Reference Clock | AD13 | I | SV _{DD} | --- |
| SD2_REF_CLK2_N | SerDes PLL 2 Reference Clock Complement | AB19 | I | SV _{DD} | --- |
| SD2_REF_CLK2_P | SerDes PLL 2 Reference Clock | AB18 | I | SV _{DD} | --- |
| SD2_RX0_N | SerDes Receive Data (negative) | AH15 | I | SV _{DD} | --- |
| SD2_RX0_P | SerDes Receive Data (positive) | AG15 | I | SV _{DD} | --- |
| SD2_RX1_N | SerDes Receive Data (negative) | AH16 | I | SV _{DD} | --- |
| SD2_RX1_P | SerDes Receive Data (positive) | AG16 | I | SV _{DD} | --- |
| SD2_RX2_N | SerDes Receive Data (negative) | AH18 | I | SV _{DD} | --- |
| SD2_RX2_P | SerDes Receive Data (positive) | AG18 | I | SV _{DD} | --- |
| SD2_RX3_N | SerDes Receive Data (negative) | AH19 | I | SV _{DD} | --- |
| SD2_RX3_P | SerDes Receive Data (positive) | AG19 | I | SV _{DD} | --- |
| SD2_TX0_N | SerDes Transmit Data (negative) | AE15 | O | XV _{DD} | --- |
| SD2_TX0_P | SerDes Transmit Data (positive) | AD15 | O | XV _{DD} | --- |
| SD2_TX1_N | SerDes Transmit Data (negative) | AE16 | O | XV _{DD} | --- |
| SD2_TX1_P | SerDes Transmit Data (positive) | AD16 | O | XV _{DD} | --- |
| SD2_TX2_N | SerDes Transmit Data (negative) | AE18 | O | XV _{DD} | --- |
| SD2_TX2_P | SerDes Transmit Data (positive) | AD18 | O | XV _{DD} | --- |
| SD2_TX3_N | SerDes Transmit Data (negative) | AE19 | O | XV _{DD} | --- |
| SD2_TX3_P | SerDes Transmit Data (positive) | AD19 | O | XV _{DD} | --- |
| USB PHY 1 | | | | | |
| USB1_D_M | USB PHY HS Data (-) | E6 | IO | - | --- |
| USB1_D_P | USB PHY HS Data (+) | F6 | IO | - | --- |
| USB1_ID | USB PHY ID Detect | F5 | I | - | --- |

Table continues on the next page...

Table 1. Pinout list by bus (continued)

| Signal | Signal description | Package pin number | Pin type | Power supply | Notes |
|---|-------------------------------|--------------------|----------|------------------|-------|
| USB1_RESREF | USB PHY Impedance Calibration | G3 | IO | - | --- |
| USB1_RX_M | USB PHY SS Receive Data (-) | E4 | I | - | --- |
| USB1_RX_P | USB PHY SS Receive Data (+) | E3 | I | - | --- |
| USB1_TX_M | USB PHY SS Transmit Data (-) | F2 | O | - | --- |
| USB1_TX_P | USB PHY SS Transmit Data (+) | F1 | O | - | --- |
| USB1_VBUS | USB PHY VBUS | E7 | I | - | --- |
| USB PHY 2 | | | | | |
| USB2_D_M | USB PHY HS Data (-) | C6 | IO | - | --- |
| USB2_D_P | USB PHY HS Data (+) | D6 | IO | - | --- |
| USB2_ID | USB PHY ID Detect | D5 | I | - | --- |
| USB2_RESREF | USB PHY Impedance Calibration | G4 | IO | - | --- |
| USB2_RX_M | USB PHY SS Receive Data (-) | C4 | I | - | --- |
| USB2_RX_P | USB PHY SS Receive Data (+) | C3 | I | - | --- |
| USB2_TX_M | USB PHY SS Transmit Data (-) | D2 | O | - | --- |
| USB2_TX_P | USB PHY SS Transmit Data (+) | D1 | O | - | --- |
| USB2_VBUS | USB PHY VBUS | C7 | I | - | --- |
| USB1 and 2 | | | | | |
| USB2_DRVVBUS/IIC3_SCL/ GPIO4_28/EVT5_B/BRGO4/ CLK11 | DRV VBus | L4 | O | DV _{DD} | 1 |
| USB2_PWRFAULT/IIC3_SDA/ GPIO4_29/EVT6_B/BRGO1/ CLK12_CLK8 | PWR Fault | M4 | I | DV _{DD} | 1 |
| USB_DRVVBUS/GPIO4_02 | USB_DRVVBUS | H6 | O | DV _{DD} | 1 |
| USB_PWRFAULT/GPIO4_03 | USB_PWRFAULT | G6 | I | DV _{DD} | 1 |
| Ethernet Management Interface 1 | | | | | |
| EMI1_MDC/GPIO4_00 | Management Data Clock | AG2 | O | LV _{DD} | 1, 13 |
| EMI1_MDIO/GPIO4_01 | Management Data In/Out | AF2 | IO | LV _{DD} | 13 |
| Ethernet Management Interface 2 | | | | | |
| EMI2_MDC/GPIO2_20 | Management Data Clock | AH4 | O | TV _{DD} | 1 |
| EMI2_MDIO/GPIO2_21 | Management Data In/Out | AH3 | IO | TV _{DD} | --- |
| Ethernet Controller 1 | | | | | |
| EC1_GTX_CLK/GPIO2_27 | Transmit Clock Out | W4 | O | LV _{DD} | 1 |
| EC1_GTX_CLK125/GPIO2_28 | Reference Clock | AC3 | I | LV _{DD} | 1 |
| EC1_RXD0/GPIO4_12 | Receive Data | AA2 | I | LV _{DD} | 1 |
| EC1_RXD1/GPIO4_11 | Receive Data | AA1 | I | LV _{DD} | 1 |

Table continues on the next page...

Table 1. Pinout list by bus (continued)

| Signal | Signal description | Package pin number | Pin type | Power supply | Notes |
|--|------------------------------|--------------------|----------|------------------|-------|
| EC1_RXD2/GPIO2_30 | Receive Data | Y1 | I | LV _{DD} | 1 |
| EC1_RXD3/GPIO2_29 | Receive Data | W2 | I | LV _{DD} | 1 |
| EC1_RX_CLK/GPIO4_13 | Receive Clock | W1 | I | LV _{DD} | 1 |
| EC1_RX_DV/GPIO4_14 | Receive Data Valid | AB1 | I | LV _{DD} | 1 |
| EC1_TXD0/GPIO2_25 | Transmit Data | AB3 | O | LV _{DD} | 1 |
| EC1_TXD1/GPIO2_24 | Transmit Data | AA3 | O | LV _{DD} | 1 |
| EC1_TXD2/GPIO2_23 | Transmit Data | Y4 | O | LV _{DD} | 1 |
| EC1_TXD3/GPIO2_22 | Transmit Data | Y3 | O | LV _{DD} | 1 |
| EC1_TX_EN/GPIO2_26 | Transmit Enable | AB4 | O | LV _{DD} | 1, 14 |
| Ethernet Controller 2 | | | | | |
| EC2_GTX_CLK/GPIO4_20 | Transmit Clock Out | AC4 | O | LV _{DD} | 1 |
| EC2_GTX_CLK125/GPIO4_21 | Reference Clock | AG4 | I | LV _{DD} | 1 |
| EC2_RXD0/GPIO4_25/ TSEC_1588_TRIG_IN2 | Receive Data | AE2 | I | LV _{DD} | 1 |
| EC2_RXD1/GPIO4_24/ TSEC_1588_PULSE_OUT1 | Receive Data | AE1 | I | LV _{DD} | 1 |
| EC2_RXD2/GPIO4_23 | Receive Data | AD1 | I | LV _{DD} | 1 |
| EC2_RXD3/GPIO4_22 | Receive Data | AC2 | I | LV _{DD} | 1 |
| EC2_RX_CLK/GPIO4_26/ TSEC_1588_CLK_IN | Receive Clock | AC1 | I | LV _{DD} | 1 |
| EC2_RX_DV/GPIO4_27/ TSEC_1588_TRIG_IN1 | Receive Data Valid | AF1 | I | LV _{DD} | 1 |
| EC2_TXD0/GPIO4_18/ TSEC_1588_PULSE_OUT2 | Transmit Data | AF3 | O | LV _{DD} | 1 |
| EC2_TXD1/GPIO4_17/ TSEC_1588_CLK_OUT | Transmit Data | AE4 | O | LV _{DD} | 1 |
| EC2_TXD2/GPIO4_16/ TSEC_1588_ALARM_OUT1 | Transmit Data | AE3 | O | LV _{DD} | 1 |
| EC2_TXD3/GPIO4_15/ TSEC_1588_ALARM_OUT2 | Transmit Data | AD3 | O | LV _{DD} | 1 |
| EC2_TX_EN/GPIO4_19 | Transmit Enable | AG3 | O | LV _{DD} | 1, 14 |
| General Purpose Input/Output | | | | | |
| GPIO1_00/IFC_AD00/ cfg_gpininput0 | General Purpose Input/Output | B12 | O | OV _{DD} | 1, 4 |
| GPIO1_01/IFC_AD01/ cfg_gpininput1 | General Purpose Input/Output | A11 | O | OV _{DD} | 1, 4 |
| GPIO1_02/IFC_AD02/ cfg_gpininput2 | General Purpose Input/Output | B11 | O | OV _{DD} | 1, 4 |
| GPIO1_03/IFC_AD03/ cfg_gpininput3 | General Purpose Input/Output | A10 | O | OV _{DD} | 1, 4 |
| GPIO1_04/IFC_AD04/ cfg_gpininput4 | General Purpose Input/Output | A9 | O | OV _{DD} | 1, 4 |

Table continues on the next page...

Table 1. Pinout list by bus (continued)

| Signal | Signal description | Package pin number | Pin type | Power supply | Notes |
|--|------------------------------|--------------------|----------|------------------|----------|
| GPIO1_05/ IFC_AD05 / cfg_gpinput5 | General Purpose Input/Output | B9 | O | OV _{DD} | 1, 4 |
| GPIO1_06/ IFC_AD06 / cfg_gpinput6 | General Purpose Input/Output | A8 | O | OV _{DD} | 1, 4 |
| GPIO1_07/ IFC_AD07 / cfg_gpinput7 | General Purpose Input/Output | B8 | O | OV _{DD} | 1, 4 |
| GPIO1_08/ IFC_AD08 / cfg_rcw_src1 | General Purpose Input/Output | A12 | O | OV _{DD} | 1, 4 |
| GPIO1_09/ IFC_AD09 / cfg_rcw_src2 | General Purpose Input/Output | A13 | O | OV _{DD} | 1, 4 |
| GPIO1_10/ IFC_AD10 / cfg_rcw_src3 | General Purpose Input/Output | B14 | O | OV _{DD} | 1, 4 |
| GPIO1_11/ IFC_AD11 / cfg_rcw_src4 | General Purpose Input/Output | A14 | O | OV _{DD} | 1, 4 |
| GPIO1_12/ IFC_AD12 / cfg_rcw_src5 | General Purpose Input/Output | B15 | O | OV _{DD} | 1, 4 |
| GPIO1_13/ IFC_AD13 / cfg_rcw_src6 | General Purpose Input/Output | A15 | O | OV _{DD} | 1, 4 |
| GPIO1_14/ IFC_AD14 / cfg_rcw_src7 | General Purpose Input/Output | A16 | O | OV _{DD} | 1, 4 |
| GPIO1_15/ IFC_AD15 / cfg_rcw_src8 | General Purpose Input/Output | A17 | O | OV _{DD} | 1, 4 |
| GPIO1_16/ IFC_A00 / QSPI_A_CS0 | General Purpose Input/Output | D8 | O | OV _{DD} | 1, 5 |
| GPIO1_17/ IFC_A01 / QSPI_A_CS1 | General Purpose Input/Output | C8 | O | OV _{DD} | 1, 5 |
| GPIO1_18/ IFC_A02 / QSPI_A_SCK | General Purpose Input/Output | C9 | O | OV _{DD} | 1, 5 |
| GPIO1_19/ IFC_A03 / QSPI_B_CS0 | General Purpose Input/Output | D10 | O | OV _{DD} | 1, 5 |
| GPIO1_20/ IFC_A04 / QSPI_B_CS1 | General Purpose Input/Output | C10 | O | OV _{DD} | 1, 5 |
| GPIO1_21/ IFC_A05 / QSPI_B_SCK/cfg_dram_type | General Purpose Input/Output | C11 | O | OV _{DD} | 1, 4 |
| GPIO1_22/ IFC_WE0_B / cfg_eng_use0 | General Purpose Input/Output | C15 | O | OV _{DD} | 1, 4, 19 |
| GPIO1_23/ IFC_TE /cfg_ifc_te | General Purpose Input/Output | E14 | O | OV _{DD} | 1, 4 |
| GPIO1_24/ IFC_ALE | General Purpose Input/Output | A18 | O | OV _{DD} | 1, 5 |
| GPIO1_25/ IFC_CLE / cfg_rcw_src0 | General Purpose Input/Output | C19 | O | OV _{DD} | 1, 4 |
| GPIO1_26/ IFC_OE_B / cfg_eng_use1 | General Purpose Input/Output | C18 | O | OV _{DD} | 1, 5 |
| GPIO1_27/ IFC_WP0_B / cfg_eng_use2 | General Purpose Input/Output | D19 | O | OV _{DD} | 1, 5 |

Table continues on the next page...

Table 1. Pinout list by bus (continued)

| Signal | Signal description | Package pin number | Pin type | Power supply | Notes |
|---|------------------------------|--------------------|----------|------------------|-------|
| GPIO1_28/ASLEEP/ cfg_soc_use | General Purpose Input/Output | E9 | O | OV _{DD} | 1, 4 |
| GPIO2_00/IFC_A06/ IFC_WP1_B/QSPI_A_DATA0 | General Purpose Input/Output | D11 | IO | OV _{DD} | --- |
| GPIO2_01/IFC_A07/ IFC_WP2_B/QSPI_A_DATA1 | General Purpose Input/Output | C12 | IO | OV _{DD} | --- |
| GPIO2_02/IFC_A08/ IFC_WP3_B/QSPI_A_DATA2 | General Purpose Input/Output | D13 | IO | OV _{DD} | --- |
| GPIO2_03/IFC_A09/ IFC_RB2_B/IFC_CS_B4/ QSPI_A_DATA3 | General Purpose Input/Output | C13 | IO | OV _{DD} | --- |
| GPIO2_04/IFC_A10/ IFC_RB3_B/IFC_CS_B5/ QSPI_A_DQS | General Purpose Input/Output | D14 | IO | OV _{DD} | --- |
| GPIO2_05/IFC_A11/ IFC_CS_B6/QSPI_B_DQS | General Purpose Input/Output | C14 | IO | OV _{DD} | --- |
| GPIO2_06/IFC_PAR0/ QSPI_B_DATA0/ QSPI_A_DATA4 | General Purpose Input/Output | B18 | IO | OV _{DD} | --- |
| GPIO2_07/IFC_PAR1/ QSPI_B_DATA1/ QSPI_A_DATA5 | General Purpose Input/Output | D17 | IO | OV _{DD} | --- |
| GPIO2_08/IFC_CS0_B | General Purpose Input/Output | C17 | IO | OV _{DD} | --- |
| GPIO2_09/IFC_CS1_B | General Purpose Input/Output | A19 | IO | OV _{DD} | --- |
| GPIO2_10/IFC_CS2_B | General Purpose Input/Output | D20 | IO | OV _{DD} | --- |
| GPIO2_11/IFC_CS3_B/ QSPI_B_DATA3/ QSPI_A_DATA7 | General Purpose Input/Output | C20 | IO | OV _{DD} | --- |
| GPIO2_12/IFC_BCTL | General Purpose Input/Output | E15 | IO | OV _{DD} | --- |
| GPIO2_13/IFC_NDDQS | General Purpose Input/Output | B17 | IO | OV _{DD} | --- |
| GPIO2_14/IFC_RB0_B | General Purpose Input/Output | C16 | IO | OV _{DD} | --- |
| GPIO2_15/IFC_RB1_B | General Purpose Input/Output | D16 | IO | OV _{DD} | --- |
| GPIO2_16/IFC_PERR_B/ QSPI_B_DATA2/ QSPI_A_DATA6 | General Purpose Input/Output | E17 | IO | OV _{DD} | --- |
| GPIO2_17/IFC_CLK0 | General Purpose Input/Output | A20 | IO | OV _{DD} | --- |
| GPIO2_18/IFC_CLK1 | General Purpose Input/Output | B20 | IO | OV _{DD} | --- |
| GPIO2_19/IFC_NDWE_B | General Purpose Input/Output | E16 | IO | OV _{DD} | --- |
| GPIO2_20/EMI2_MDC | General Purpose Input/Output | AH4 | IO | TV _{DD} | --- |
| GPIO2_21/EMI2_MDIO | General Purpose Input/Output | AH3 | IO | TV _{DD} | --- |
| GPIO2_22/EC1_TXD3 | General Purpose Input/Output | Y3 | IO | LV _{DD} | --- |
| GPIO2_23/EC1_TXD2 | General Purpose Input/Output | Y4 | IO | LV _{DD} | --- |
| GPIO2_24/EC1_TXD1 | General Purpose Input/Output | AA3 | IO | LV _{DD} | --- |

Table continues on the next page...

Table 1. Pinout list by bus (continued)

| Signal | Signal description | Package pin number | Pin type | Power supply | Notes |
|---|------------------------------|--------------------|----------|------------------|-------|
| GPIO2_25/EC1_TXD0 | General Purpose Input/Output | AB3 | IO | LV _{DD} | --- |
| GPIO2_26/EC1_TX_EN | General Purpose Input/Output | AB4 | IO | LV _{DD} | --- |
| GPIO2_27/EC1_GTX_CLK | General Purpose Input/Output | W4 | IO | LV _{DD} | --- |
| GPIO2_28/EC1_GTX_CLK125 | General Purpose Input/Output | AC3 | IO | LV _{DD} | --- |
| GPIO2_29/EC1_RXD3 | General Purpose Input/Output | W2 | IO | LV _{DD} | --- |
| GPIO2_30/EC1_RXD2 | General Purpose Input/Output | Y1 | IO | LV _{DD} | --- |
| GPIO3_06/UART2_SOUT | General Purpose Input/Output | L2 | IO | DV _{DD} | --- |
| GPIO3_07/UART2_SIN | General Purpose Input/Output | K1 | IO | DV _{DD} | --- |
| GPIO3_08/UART1_RTS_B/ UART3_SOUT | General Purpose Input/Output | J2 | IO | DV _{DD} | --- |
| GPIO3_09/UART2_RTS_B/ UART4_SOUT | General Purpose Input/Output | L1 | IO | DV _{DD} | --- |
| GPIO3_10/UART1_CTS_B/ UART3_SIN | General Purpose Input/Output | J1 | IO | DV _{DD} | --- |
| GPIO3_11/UART2_CTS_B/ UART4_SIN | General Purpose Input/Output | M2 | IO | DV _{DD} | --- |
| GPIO3_12/IIC2_SCL/ SDHC_CD_B/CLK9/BRGO2 | General Purpose Input/Output | K3 | IO | DV _{DD} | --- |
| GPIO3_13/IIC2_SDA/ SDHC_WP/CLK10/BRGO3 | General Purpose Input/Output | L3 | IO | DV _{DD} | --- |
| GPIO3_14/SPI_SOUT/ SDHC_CLK_SYNC_OUT | General Purpose Input/Output | V3 | IO | OV _{DD} | --- |
| GPIO3_15/SPI_SIN/ SDHC_CLK_SYNC_IN | General Purpose Input/Output | U3 | IO | OV _{DD} | --- |
| GPIO3_16/SPI_SCK/ SDHC_GATE_IN | General Purpose Input/Output | U2 | IO | OV _{DD} | --- |
| GPIO3_17/SPI_PCS0/ SDHC_DAT4/SDHC_VS | General Purpose Input/Output | U1 | IO | OV _{DD} | --- |
| GPIO3_18/SPI_PCS1/ SDHC_DAT5/ SDHC_CMD_DIR | General Purpose Input/Output | R3 | IO | OV _{DD} | --- |
| GPIO3_19/SPI_PCS2/ SDHC_DAT6/ SDHC_DAT0_DIR | General Purpose Input/Output | T3 | IO | OV _{DD} | --- |
| GPIO3_20/SPI_PCS3/ SDHC_DAT7/ SDHC_DAT123_DIR | General Purpose Input/Output | V1 | IO | OV _{DD} | --- |
| GPIO3_21/SDHC_CMD | General Purpose Input/Output | P2 | IO | EV _{DD} | --- |
| GPIO3_22/SDHC_DAT0 | General Purpose Input/Output | P1 | IO | EV _{DD} | --- |
| GPIO3_23/SDHC_DAT1 | General Purpose Input/Output | R2 | IO | EV _{DD} | --- |
| GPIO3_24/SDHC_DAT2 | General Purpose Input/Output | R1 | IO | EV _{DD} | --- |
| GPIO3_25/SDHC_DAT3 | General Purpose Input/Output | T1 | IO | EV _{DD} | --- |
| GPIO3_26/SDHC_CLK | General Purpose Input/Output | P3 | IO | EV _{DD} | --- |

Table continues on the next page...

Table 1. Pinout list by bus (continued)

| Signal | Signal description | Package pin number | Pin type | Power supply | Notes |
|--|------------------------------|--------------------|----------|------------------|-------|
| GPIO3_27/ IRQ03 / TDMB_TSYNC/ UC3_RTSB_TXEN | General Purpose Input/Output | J3 | IO | DV _{DD} | --- |
| GPIO3_28/ IRQ04 / TDMA_RXD/UC1_RXD7/ TDMA_TXD | General Purpose Input/Output | J4 | IO | DV _{DD} | --- |
| GPIO3_29/ IRQ05 / TDMA_RSYNC/ UC1_CTSB_RXDV | General Purpose Input/Output | J5 | IO | DV _{DD} | --- |
| GPIO3_30/ RTC | General Purpose Input/Output | F17 | IO | OV _{DD} | --- |
| GPIO4_00/ EMI1_MDC | General Purpose Input/Output | AG2 | IO | LV _{DD} | --- |
| GPIO4_01/ EMI1_MDIO | General Purpose Input/Output | AF2 | IO | LV _{DD} | --- |
| GPIO4_02/ USB_DRVVBUS | General Purpose Input/Output | H6 | IO | DV _{DD} | --- |
| GPIO4_03/ USB_PWRFAULT | General Purpose Input/Output | G6 | IO | DV _{DD} | --- |
| GPIO4_04/ IRQ06 / TDMA_RXD_EXC/ TDMA_TXD/UC1_TXD7 | General Purpose Input/Output | K5 | IO | DV _{DD} | --- |
| GPIO4_05/ IRQ07 / TDMA_TSYNC/ UC1_RTSB_TXEN | General Purpose Input/Output | L5 | IO | DV _{DD} | --- |
| GPIO4_06/ IRQ08 / TDMB_RXD/UC3_RXD7/ TDMB_TXD | General Purpose Input/Output | M5 | IO | DV _{DD} | --- |
| GPIO4_07/ IRQ09 / TDMB_RSYNC/ UC3_CTSB_RXDV | General Purpose Input/Output | N5 | IO | DV _{DD} | --- |
| GPIO4_08/ IRQ10 / TDMB_RXD_EXC/ TDMB_TXD/UC3_TXD7 | General Purpose Input/Output | P4 | IO | DV _{DD} | --- |
| GPIO4_09/ IRQ11 | General Purpose Input/Output | W3 | IO | LV _{DD} | --- |
| GPIO4_10/ EVT9_B | General Purpose Input/Output | G7 | IO | OV _{DD} | --- |
| GPIO4_11/ EC1_RXD1 | General Purpose Input/Output | AA1 | IO | LV _{DD} | --- |
| GPIO4_12/ EC1_RXD0 | General Purpose Input/Output | AA2 | IO | LV _{DD} | --- |
| GPIO4_13/ EC1_RX_CLK | General Purpose Input/Output | W1 | IO | LV _{DD} | --- |
| GPIO4_14/ EC1_RX_DV | General Purpose Input/Output | AB1 | IO | LV _{DD} | --- |
| GPIO4_15/ EC2_TXD3 / TSEC_1588_ALARM_OUT2 | General Purpose Input/Output | AD3 | IO | LV _{DD} | --- |
| GPIO4_16/ EC2_TXD2 / TSEC_1588_ALARM_OUT1 | General Purpose Input/Output | AE3 | IO | LV _{DD} | --- |
| GPIO4_17/ EC2_TXD1 / TSEC_1588_CLK_OUT | General Purpose Input/Output | AE4 | IO | LV _{DD} | --- |
| GPIO4_18/ EC2_TXD0 / TSEC_1588_PULSE_OUT2 | General Purpose Input/Output | AF3 | IO | LV _{DD} | --- |
| GPIO4_19/ EC2_TX_EN | General Purpose Input/Output | AG3 | IO | LV _{DD} | --- |

Table continues on the next page...

Table 1. Pinout list by bus (continued)

| Signal | Signal description | Package pin number | Pin type | Power supply | Notes |
|---|------------------------------|--------------------|----------|------------------|----------|
| GPIO4_20/EC2_GTX_CLK | General Purpose Input/Output | AC4 | IO | LV _{DD} | --- |
| GPIO4_21/EC2_GTX_CLK125 | General Purpose Input/Output | AG4 | IO | LV _{DD} | --- |
| GPIO4_22/EC2_RXD3 | General Purpose Input/Output | AC2 | IO | LV _{DD} | --- |
| GPIO4_23/EC2_RXD2 | General Purpose Input/Output | AD1 | IO | LV _{DD} | --- |
| GPIO4_24/EC2_RXD1/ TSEC_1588_PULSE_OUT1 | General Purpose Input/Output | AE1 | IO | LV _{DD} | --- |
| GPIO4_25/EC2_RXD0/ TSEC_1588_TRIG_IN2 | General Purpose Input/Output | AE2 | IO | LV _{DD} | --- |
| GPIO4_26/EC2_RX_CLK/ TSEC_1588_CLK_IN | General Purpose Input/Output | AC1 | IO | LV _{DD} | --- |
| GPIO4_27/EC2_RX_DV/ TSEC_1588_TRIG_IN1 | General Purpose Input/Output | AF1 | IO | LV _{DD} | --- |
| GPIO4_28/IIC3_SCL/EVT5_B/ USB2_DRVVBUS/BRGO4/ CLK11 | General Purpose Input/Output | L4 | IO | DV _{DD} | --- |
| GPIO4_29/IIC3_SDA/EVT6_B/ USB2_PWRFAULT/BRGO1/ CLK12_CLK8 | General Purpose Input/Output | M4 | IO | DV _{DD} | --- |
| GPIO4_30/IIC4_SCL/EVT7_B/ TDMA_RQ/UC1_CDB_RXER | General Purpose Input/Output | M3 | IO | DV _{DD} | --- |
| GPIO4_31/IIC4_SDA/EVT8_B/ TDMB_RQ/UC3_CDB_RXER | General Purpose Input/Output | N3 | IO | DV _{DD} | --- |
| Power-On-Reset Configuration | | | | | |
| cfg_eng_use0/IFC_WE0_B/ GPIO1_22 | Power-on-Reset Configuration | C15 | I | OV _{DD} | 1, 4, 19 |
| cfg_eng_use1/IFC_OE_B/ GPIO1_26 | Power-on-Reset Configuration | C18 | I | OV _{DD} | 1, 5 |
| cfg_eng_use2/IFC_WP0_B/ GPIO1_27 | Power-on-Reset Configuration | D19 | I | OV _{DD} | 1, 5 |
| cfg_gpinput0/IFC_AD00/ GPIO1_00 | Power-on-Reset Configuration | B12 | I | OV _{DD} | 1, 4 |
| cfg_gpinput1/IFC_AD01/ GPIO1_01 | Power-on-Reset Configuration | A11 | I | OV _{DD} | 1, 4 |
| cfg_gpinput2/IFC_AD02/ GPIO1_02 | Power-on-Reset Configuration | B11 | I | OV _{DD} | 1, 4 |
| cfg_gpinput3/IFC_AD03/ GPIO1_03 | Power-on-Reset Configuration | A10 | I | OV _{DD} | 1, 4 |
| cfg_gpinput4/IFC_AD04/ GPIO1_04 | Power-on-Reset Configuration | A9 | I | OV _{DD} | 1, 4 |
| cfg_gpinput5/IFC_AD05/ GPIO1_05 | Power-on-Reset Configuration | B9 | I | OV _{DD} | 1, 4 |
| cfg_gpinput6/IFC_AD06/ GPIO1_06 | Power-on-Reset Configuration | A8 | I | OV _{DD} | 1, 4 |

Table continues on the next page...

Table 1. Pinout list by bus (continued)

| Signal | Signal description | Package pin number | Pin type | Power supply | Notes |
|--|------------------------------|--------------------|----------|------------------|-------|
| cfg_gpinput7/ IFC_AD07 / GPIO1_07 | Power-on-Reset Configuration | B8 | I | OV _{DD} | 1, 4 |
| cfg_ifc_te/ IFC_TE / GPIO1_23 | Power-on-Reset Configuration | E14 | I | OV _{DD} | 1, 4 |
| cfg_rcw_src0/ IFC_CLE / GPIO1_25 | Power-on-Reset Configuration | C19 | I | OV _{DD} | 1, 4 |
| cfg_rcw_src1/ IFC_AD08 / GPIO1_08 | Power-on-Reset Configuration | A12 | I | OV _{DD} | 1, 4 |
| cfg_rcw_src2/ IFC_AD09 / GPIO1_09 | Power-on-Reset Configuration | A13 | I | OV _{DD} | 1, 4 |
| cfg_rcw_src3/ IFC_AD10 / GPIO1_10 | Power-on-Reset Configuration | B14 | I | OV _{DD} | 1, 4 |
| cfg_rcw_src4/ IFC_AD11 / GPIO1_11 | Power-on-Reset Configuration | A14 | I | OV _{DD} | 1, 4 |
| cfg_rcw_src5/ IFC_AD12 / GPIO1_12 | Power-on-Reset Configuration | B15 | I | OV _{DD} | 1, 4 |
| cfg_rcw_src6/ IFC_AD13 / GPIO1_13 | Power-on-Reset Configuration | A15 | I | OV _{DD} | 1, 4 |
| cfg_rcw_src7/ IFC_AD14 / GPIO1_14 | Power-on-Reset Configuration | A16 | I | OV _{DD} | 1, 4 |
| cfg_rcw_src8/ IFC_AD15 / GPIO1_15 | Power-on-Reset Configuration | A17 | I | OV _{DD} | 1, 4 |
| Quad SPI | | | | | |
| QSPI_A_CS0/ IFC_A00 / GPIO1_16 | Chip Select | D8 | O | OV _{DD} | 1, 5 |
| QSPI_A_CS1/ IFC_A01 / GPIO1_17 | CS1 | C8 | O | OV _{DD} | 1, 5 |
| QSPI_A_DATA0/ IFC_A06 / GPIO2_00/ IFC_WP1_B | DATA0 | D11 | IO | OV _{DD} | --- |
| QSPI_A_DATA1/ IFC_A07 / GPIO2_01/ IFC_WP2_B | DATA1 | C12 | IO | OV _{DD} | --- |
| QSPI_A_DATA2/ IFC_A08 / GPIO2_02/ IFC_WP3_B | DATA2 | D13 | IO | OV _{DD} | --- |
| QSPI_A_DATA3/ IFC_A09 / GPIO2_03/ IFC_RB2_B / IFC_CS_B4 | DATA3 | C13 | IO | OV _{DD} | --- |
| QSPI_A_DATA4/ IFC_PAR0 / GPIO2_06/ QSPI_B_DATA0 | DATA4 | B18 | IO | OV _{DD} | --- |
| QSPI_A_DATA5/ IFC_PAR1 / GPIO2_07/ QSPI_B_DATA1 | DATA5 | D17 | IO | OV _{DD} | --- |
| QSPI_A_DATA6/ IFC_PERR_B / GPIO2_16/ QSPI_B_DATA2 | DATA6 | E17 | IO | OV _{DD} | --- |
| QSPI_A_DATA7/ IFC_CS3_B / GPIO2_11/ QSPI_B_DATA3 | DATA7 | C20 | IO | OV _{DD} | --- |

Table continues on the next page...

Table 1. Pinout list by bus (continued)

| Signal | Signal description | Package pin number | Pin type | Power supply | Notes |
|---|----------------------------|--------------------|----------|------------------|-------|
| QSPI_A_DQS/IFC_A10/ GPIO2_04/IFC_RB3_B/ IFC_CS_B5 | DQS | D14 | I | OV _{DD} | 1 |
| QSPI_A_SCK/IFC_A02/ GPIO1_18 | SCK | C9 | O | OV _{DD} | 1, 5 |
| QSPI_B_CS0/IFC_A03/ GPIO1_19 | Chip Select | D10 | O | OV _{DD} | 1, 5 |
| QSPI_B_CS1/IFC_A04/ GPIO1_20 | CS1 | C10 | O | OV _{DD} | 1, 5 |
| QSPI_B_DATA0/IFC_PAR0/ GPIO2_06/QSPI_A_DATA4 | DATA0 | B18 | IO | OV _{DD} | --- |
| QSPI_B_DATA1/IFC_PAR1/ GPIO2_07/QSPI_A_DATA5 | DATA1 | D17 | IO | OV _{DD} | --- |
| QSPI_B_DATA2/ IFC_PERR_B/GPIO2_16/ QSPI_A_DATA6 | DATA2 | E17 | IO | OV _{DD} | --- |
| QSPI_B_DATA3/IFC_CS3_B/ GPIO2_11/QSPI_A_DATA7 | DATA3 | C20 | IO | OV _{DD} | --- |
| QSPI_B_DQS/IFC_A11/ GPIO2_05/IFC_CS_B6 | DQS | C14 | I | OV _{DD} | 1 |
| QSPI_B_SCK/IFC_A05/ GPIO1_21/cfg_dram_type | SCK | C11 | O | OV _{DD} | 1, 4 |
| QUICC Engine | | | | | |
| BRGO1/IIC3_SDA/GPIO4_29/ EVT6_B/USB2_PWRFAULT/ CLK12_CLK8 | Baud Rate Generator Output | M4 | O | DV _{DD} | 1 |
| BRGO2/IIC2_SCL/GPIO3_12/ SDHC_CD_B/CLK9 | Baud Rate Generator Output | K3 | O | DV _{DD} | 1 |
| BRGO3/IIC2_SDA/GPIO3_13/ SDHC_WP/CLK10 | Baud Rate Generator Output | L3 | O | DV _{DD} | 1 |
| BRGO4/IIC3_SCL/GPIO4_28/ EVT5_B/USB2_DRVVBUS/ CLK11 | Baud Rate Generator Output | L4 | O | DV _{DD} | 1 |
| CLK10/IIC2_SDA/GPIO3_13/ SDHC_WP/BRGO3 | Clock | L3 | I | DV _{DD} | 1 |
| CLK9/IIC2_SCL/GPIO3_12/ SDHC_CD_B/BRGO2 | Clock | K3 | I | DV _{DD} | 1 |
| TDMA_RQ/IIC4_SCL/ GPIO4_30/EVT7_B/ UC1_CDB_RXER | RQ | M3 | O | DV _{DD} | 1 |
| TDMB_RQ/IIC4_SDA/ GPIO4_31/EVT8_B/ UC3_CDB_RXER | RQ | N3 | O | DV _{DD} | 1 |
| UC1_CDB_RXER/IIC4_SCL/ GPIO4_30/EVT7_B/TDMA_RQ | Receive Error | M3 | I | DV _{DD} | 1 |

Table continues on the next page...

Table 1. Pinout list by bus (continued)

| Signal | Signal description | Package pin number | Pin type | Power supply | Notes |
|--|--------------------|--------------------|----------|------------------|-------|
| UC1_CTSB_RXDV/ IRQ05 / GPIO3_29/TDMA_RSYNC | Receive Data | J5 | I | DV _{DD} | 1 |
| UC1_RTSB_TXEN/ IRQ07 / GPIO4_05/TDMA_TSYNC | Transmit Enable | L5 | O | DV _{DD} | 1 |
| UC1_RXD7/ IRQ04 /GPIO3_28/ TDMA_RXD/TDMA_TXD | Receive Data | J4 | I | DV _{DD} | 1 |
| UC1_TXD7/ IRQ06 /GPIO4_04/ TDMA_RXD_EXC/TDMA_TXD | Transmit Data | K5 | O | DV _{DD} | 1 |
| UC3_CDB_RXER/ IIC4_SDA / GPIO4_31/EVT8_B/TDMB_RQ | Receive Error | N3 | I | DV _{DD} | 1 |
| UC3_CTSB_RXDV/ IRQ09 / GPIO4_07/TDMB_RSYNC | Receive Data | N5 | I | DV _{DD} | 1 |
| UC3_RTSB_TXEN/ IRQ03 / GPIO3_27/TDMB_TSYNC | Transmit Enable | J3 | O | DV _{DD} | 1 |
| UC3_RXD7/ IRQ08 /GPIO4_06/ TDMB_RXD/TDMB_TXD | Receive Data | M5 | I | DV _{DD} | 1 |
| UC3_TXD7/ IRQ10 /GPIO4_08/ TDMB_RXD_EXC/TDMB_TXD | Transmit Data | P4 | O | DV _{DD} | 1 |
| Time Division Multiplexing | | | | | |
| TDMA_RSYNC/ IRQ05 / GPIO3_29/UC1_CTSB_RXDV | RSYNC | J5 | I | DV _{DD} | 1 |
| TDMA_RXD/ IRQ04 / GPIO3_28/UC1_RXD7/ TDMA_TXD | RXD | J4 | I | DV _{DD} | 1 |
| TDMA_RXD_EXC/ IRQ06 / GPIO4_04/TDMA_TXD/ UC1_TXD7 | Receive Data | K5 | I | DV _{DD} | 1 |
| TDMA_TSYNC/ IRQ07 / GPIO4_05/UC1_RTSB_TXEN | TSYNC | L5 | I | DV _{DD} | 1 |
| TDMA_TXD/ IRQ04 /GPIO3_28/ TDMA_RXD/UC1_RXD7 | Transmit Data | J4 | O | DV _{DD} | 1 |
| TDMA_TXD/ IRQ06 /GPIO4_04/ TDMA_RXD_EXC/UC1_TXD7 | Transmit Data | K5 | O | DV _{DD} | 1 |
| TDMB_RSYNC/ IRQ09 / GPIO4_07/UC3_CTSB_RXDV | RSYNC | N5 | I | DV _{DD} | 1 |
| TDMB_RXD/ IRQ08 / GPIO4_06/UC3_RXD7/ TDMB_TXD | RXD | M5 | I | DV _{DD} | 1 |
| TDMB_RXD_EXC/ IRQ10 / GPIO4_08/TDMB_TXD/ UC3_TXD7 | Receive Data | P4 | I | DV _{DD} | 1 |
| TDMB_TSYNC/ IRQ03 / GPIO3_27/UC3_RTSB_TXEN | TSYNC | J3 | I | DV _{DD} | 1 |
| TDMB_TXD/ IRQ08 /GPIO4_06/ TDMB_RXD/UC3_RXD7 | Transmit Data | M5 | O | DV _{DD} | 1 |

Table continues on the next page...

Table 1. Pinout list by bus (continued)

| Signal | Signal description | Package pin number | Pin type | Power supply | Notes |
|---|----------------------------------|--------------------|----------|------------------|-------|
| TDMB_TXD/IRQ10/GPIO4_08/ TDMB_RXD_EXC/UC3_TXD7 | Transmit Data | P4 | O | DV _{DD} | 1 |
| IEEE 1588 | | | | | |
| TSEC_1588_ALARM_OUT1/ EC2_TXD2/GPIO4_16 | Alarm Out | AE3 | O | LV _{DD} | 1 |
| TSEC_1588_ALARM_OUT2/ EC2_TXD3/GPIO4_15 | Alarm Out | AD3 | O | LV _{DD} | 1 |
| TSEC_1588_CLK_IN/ EC2_RX_CLK/GPIO4_26 | Clock In | AC1 | I | LV _{DD} | 1 |
| TSEC_1588_CLK_OUT/ EC2_TXD1/GPIO4_17 | Clock Out | AE4 | O | LV _{DD} | 1 |
| TSEC_1588_PULSE_OUT1/ EC2_RXD1/GPIO4_24 | Pulse Out | AE1 | O | LV _{DD} | 1 |
| TSEC_1588_PULSE_OUT2/ EC2_TXD0/GPIO4_18 | Pulse Out | AF3 | O | LV _{DD} | 1 |
| TSEC_1588_TRIG_IN1/ EC2_RX_DV/GPIO4_27 | Trigger In | AF1 | I | LV _{DD} | 1 |
| TSEC_1588_TRIG_IN2/ EC2_RXD0/GPIO4_25 | Trigger In | AE2 | I | LV _{DD} | 1 |
| TMR | | | | | |
| CLK11/IIC3_SCL/GPIO4_28/ EVT5_B/USB2_DRVVBUS/ BRGO4 | Clock #11 | L4 | I | DV _{DD} | 1 |
| CLK12_CLK8/IIC3_SDA/ GPIO4_29/EVT6_B/ USB2_PWRFAULT/BRGO1 | CLK8 | M4 | I | DV _{DD} | 1 |
| Power and Ground Signals | | | | | |
| GND001 | Core, Platform and PLL Ground | A2 | --- | --- | --- |
| GND002 | Core, Platform and PLL Ground | A5 | --- | --- | --- |
| GND003 | Core, Platform and PLL Ground | A21 | --- | --- | --- |
| GND004 | Core, Platform and PLL Ground | B3 | --- | --- | --- |
| GND005 | Core, Platform and PLL Ground | B4 | --- | --- | --- |
| GND006 | Core, Platform and PLL Ground | B7 | --- | --- | --- |
| GND007 | Core, Platform and PLL Ground | B10 | --- | --- | --- |
| GND008 | Core, Platform and PLL Ground | B13 | --- | --- | --- |

Table continues on the next page...

Table 1. Pinout list by bus (continued)

| Signal | Signal description | Package pin number | Pin type | Power supply | Notes |
|--------|-------------------------------|--------------------|----------|--------------|-------|
| GND009 | Core, Platform and PLL Ground | B16 | --- | --- | --- |
| GND010 | Core, Platform and PLL Ground | B19 | --- | --- | --- |
| GND011 | Core, Platform and PLL Ground | B21 | --- | --- | --- |
| GND012 | Core, Platform and PLL Ground | B24 | --- | --- | --- |
| GND013 | Core, Platform and PLL Ground | B26 | --- | --- | --- |
| GND014 | Core, Platform and PLL Ground | C1 | --- | --- | --- |
| GND015 | Core, Platform and PLL Ground | C2 | --- | --- | --- |
| GND016 | Core, Platform and PLL Ground | C5 | --- | --- | --- |
| GND017 | Core, Platform and PLL Ground | C21 | --- | --- | --- |
| GND018 | Core, Platform and PLL Ground | C27 | --- | --- | --- |
| GND019 | Core, Platform and PLL Ground | D3 | --- | --- | --- |
| GND020 | Core, Platform and PLL Ground | D4 | --- | --- | --- |
| GND021 | Core, Platform and PLL Ground | D7 | --- | --- | --- |
| GND022 | Core, Platform and PLL Ground | D9 | --- | --- | --- |
| GND023 | Core, Platform and PLL Ground | D12 | --- | --- | --- |
| GND024 | Core, Platform and PLL Ground | D15 | --- | --- | --- |
| GND025 | Core, Platform and PLL Ground | D18 | --- | --- | --- |
| GND026 | Core, Platform and PLL Ground | D21 | --- | --- | --- |
| GND027 | Core, Platform and PLL Ground | D24 | --- | --- | --- |
| GND028 | Core, Platform and PLL Ground | E1 | --- | --- | --- |
| GND029 | Core, Platform and PLL Ground | E2 | --- | --- | --- |
| GND030 | Core, Platform and PLL Ground | E5 | --- | --- | --- |

Table continues on the next page...

Table 1. Pinout list by bus (continued)

| Signal | Signal description | Package pin number | Pin type | Power supply | Notes |
|--------|-------------------------------|--------------------|----------|--------------|-------|
| GND031 | Core, Platform and PLL Ground | E21 | --- | --- | --- |
| GND032 | Core, Platform and PLL Ground | E26 | --- | --- | --- |
| GND033 | Core, Platform and PLL Ground | F3 | --- | --- | --- |
| GND034 | Core, Platform and PLL Ground | F4 | --- | --- | --- |
| GND035 | Core, Platform and PLL Ground | F7 | --- | --- | --- |
| GND036 | Core, Platform and PLL Ground | F14 | --- | --- | --- |
| GND037 | Core, Platform and PLL Ground | F16 | --- | --- | --- |
| GND038 | Core, Platform and PLL Ground | F18 | --- | --- | --- |
| GND039 | Core, Platform and PLL Ground | F24 | --- | --- | --- |
| GND040 | Core, Platform and PLL Ground | G1 | --- | --- | --- |
| GND041 | Core, Platform and PLL Ground | G2 | --- | --- | --- |
| GND042 | Core, Platform and PLL Ground | G9 | --- | --- | --- |
| GND043 | Core, Platform and PLL Ground | G10 | --- | --- | --- |
| GND044 | Core, Platform and PLL Ground | G11 | --- | --- | --- |
| GND045 | Core, Platform and PLL Ground | G21 | --- | --- | --- |
| GND046 | Core, Platform and PLL Ground | G26 | --- | --- | --- |
| GND047 | Core, Platform and PLL Ground | H3 | --- | --- | --- |
| GND048 | Core, Platform and PLL Ground | H4 | --- | --- | --- |
| GND049 | Core, Platform and PLL Ground | H5 | --- | --- | --- |
| GND050 | Core, Platform and PLL Ground | H14 | --- | --- | --- |
| GND051 | Core, Platform and PLL Ground | H15 | --- | --- | --- |
| GND052 | Core, Platform and PLL Ground | H16 | --- | --- | --- |

Table continues on the next page...

Table 1. Pinout list by bus (continued)

| Signal | Signal description | Package pin number | Pin type | Power supply | Notes |
|--------|-------------------------------|--------------------|----------|--------------|-------|
| GND053 | Core, Platform and PLL Ground | H17 | --- | --- | --- |
| GND054 | Core, Platform and PLL Ground | H18 | --- | --- | --- |
| GND055 | Core, Platform and PLL Ground | H21 | --- | --- | --- |
| GND056 | Core, Platform and PLL Ground | H24 | --- | --- | --- |
| GND057 | Core, Platform and PLL Ground | J6 | --- | --- | --- |
| GND058 | Core, Platform and PLL Ground | J7 | --- | --- | --- |
| GND059 | Core, Platform and PLL Ground | J8 | --- | --- | --- |
| GND060 | Core, Platform and PLL Ground | J9 | --- | --- | --- |
| GND061 | Core, Platform and PLL Ground | J10 | --- | --- | --- |
| GND062 | Core, Platform and PLL Ground | J11 | --- | --- | --- |
| GND063 | Core, Platform and PLL Ground | J12 | --- | --- | --- |
| GND064 | Core, Platform and PLL Ground | J21 | --- | --- | --- |
| GND065 | Core, Platform and PLL Ground | J23 | --- | --- | --- |
| GND066 | Core, Platform and PLL Ground | J26 | --- | --- | --- |
| GND067 | Core, Platform and PLL Ground | K2 | --- | --- | --- |
| GND068 | Core, Platform and PLL Ground | K4 | --- | --- | --- |
| GND069 | Core, Platform and PLL Ground | K6 | --- | --- | --- |
| GND070 | Core, Platform and PLL Ground | K13 | --- | --- | --- |
| GND071 | Core, Platform and PLL Ground | K15 | --- | --- | --- |
| GND072 | Core, Platform and PLL Ground | K17 | --- | --- | --- |
| GND073 | Core, Platform and PLL Ground | K19 | --- | --- | --- |
| GND074 | Core, Platform and PLL Ground | K21 | --- | --- | --- |

Table continues on the next page...

Table 1. Pinout list by bus (continued)

| Signal | Signal description | Package pin number | Pin type | Power supply | Notes |
|--------|-------------------------------|--------------------|----------|--------------|-------|
| GND075 | Core, Platform and PLL Ground | L6 | --- | --- | --- |
| GND076 | Core, Platform and PLL Ground | L10 | --- | --- | --- |
| GND077 | Core, Platform and PLL Ground | L12 | --- | --- | --- |
| GND078 | Core, Platform and PLL Ground | L14 | --- | --- | --- |
| GND079 | Core, Platform and PLL Ground | L16 | --- | --- | --- |
| GND080 | Core, Platform and PLL Ground | L18 | --- | --- | --- |
| GND081 | Core, Platform and PLL Ground | L20 | --- | --- | --- |
| GND082 | Core, Platform and PLL Ground | L23 | --- | --- | --- |
| GND083 | Core, Platform and PLL Ground | L26 | --- | --- | --- |
| GND084 | Core, Platform and PLL Ground | M6 | --- | --- | --- |
| GND085 | Core, Platform and PLL Ground | M9 | --- | --- | --- |
| GND086 | Core, Platform and PLL Ground | M11 | --- | --- | --- |
| GND087 | Core, Platform and PLL Ground | M13 | --- | --- | --- |
| GND088 | Core, Platform and PLL Ground | M15 | --- | --- | --- |
| GND089 | Core, Platform and PLL Ground | M17 | --- | --- | --- |
| GND090 | Core, Platform and PLL Ground | M19 | --- | --- | --- |
| GND091 | Core, Platform and PLL Ground | M21 | --- | --- | --- |
| GND092 | Core, Platform and PLL Ground | M23 | --- | --- | --- |
| GND093 | Core, Platform and PLL Ground | N2 | --- | --- | --- |
| GND094 | Core, Platform and PLL Ground | N4 | --- | --- | --- |
| GND095 | Core, Platform and PLL Ground | N6 | --- | --- | --- |
| GND096 | Core, Platform and PLL Ground | N8 | --- | --- | --- |

Table continues on the next page...

Table 1. Pinout list by bus (continued)

| Signal | Signal description | Package pin number | Pin type | Power supply | Notes |
|--------|-------------------------------|--------------------|----------|--------------|-------|
| GND097 | Core, Platform and PLL Ground | N10 | --- | --- | --- |
| GND098 | Core, Platform and PLL Ground | N12 | --- | --- | --- |
| GND099 | Core, Platform and PLL Ground | N14 | --- | --- | --- |
| GND100 | Core, Platform and PLL Ground | N16 | --- | --- | --- |
| GND101 | Core, Platform and PLL Ground | N18 | --- | --- | --- |
| GND102 | Core, Platform and PLL Ground | N20 | --- | --- | --- |
| GND103 | Core, Platform and PLL Ground | N23 | --- | --- | --- |
| GND104 | Core, Platform and PLL Ground | N26 | --- | --- | --- |
| GND105 | Core, Platform and PLL Ground | P6 | --- | --- | --- |
| GND106 | Core, Platform and PLL Ground | P9 | --- | --- | --- |
| GND107 | Core, Platform and PLL Ground | P11 | --- | --- | --- |
| GND108 | Core, Platform and PLL Ground | P13 | --- | --- | --- |
| GND109 | Core, Platform and PLL Ground | P15 | --- | --- | --- |
| GND110 | Core, Platform and PLL Ground | P17 | --- | --- | --- |
| GND111 | Core, Platform and PLL Ground | P19 | --- | --- | --- |
| GND112 | Core, Platform and PLL Ground | P23 | --- | --- | --- |
| GND113 | Core, Platform and PLL Ground | R5 | --- | --- | --- |
| GND114 | Core, Platform and PLL Ground | R8 | --- | --- | --- |
| GND115 | Core, Platform and PLL Ground | R10 | --- | --- | --- |
| GND116 | Core, Platform and PLL Ground | R12 | --- | --- | --- |
| GND117 | Core, Platform and PLL Ground | R14 | --- | --- | --- |
| GND118 | Core, Platform and PLL Ground | R16 | --- | --- | --- |

Table continues on the next page...

Table 1. Pinout list by bus (continued)

| Signal | Signal description | Package pin number | Pin type | Power supply | Notes |
|--------|-------------------------------|--------------------|----------|--------------|-------|
| GND119 | Core, Platform and PLL Ground | R18 | --- | --- | --- |
| GND120 | Core, Platform and PLL Ground | R20 | --- | --- | --- |
| GND121 | Core, Platform and PLL Ground | R23 | --- | --- | --- |
| GND122 | Core, Platform and PLL Ground | R26 | --- | --- | --- |
| GND123 | Core, Platform and PLL Ground | T2 | --- | --- | --- |
| GND124 | Core, Platform and PLL Ground | T4 | --- | --- | --- |
| GND125 | Core, Platform and PLL Ground | T6 | --- | --- | --- |
| GND126 | Core, Platform and PLL Ground | T9 | --- | --- | --- |
| GND127 | Core, Platform and PLL Ground | T11 | --- | --- | --- |
| GND128 | Core, Platform and PLL Ground | T13 | --- | --- | --- |
| GND129 | Core, Platform and PLL Ground | T15 | --- | --- | --- |
| GND130 | Core, Platform and PLL Ground | T17 | --- | --- | --- |
| GND131 | Core, Platform and PLL Ground | T19 | --- | --- | --- |
| GND132 | Core, Platform and PLL Ground | T21 | --- | --- | --- |
| GND133 | Core, Platform and PLL Ground | T23 | --- | --- | --- |
| GND134 | Core, Platform and PLL Ground | T26 | --- | --- | --- |
| GND135 | Core, Platform and PLL Ground | U6 | --- | --- | --- |
| GND136 | Core, Platform and PLL Ground | U8 | --- | --- | --- |
| GND137 | Core, Platform and PLL Ground | U10 | --- | --- | --- |
| GND138 | Core, Platform and PLL Ground | U12 | --- | --- | --- |
| GND139 | Core, Platform and PLL Ground | U14 | --- | --- | --- |
| GND140 | Core, Platform and PLL Ground | U16 | --- | --- | --- |

Table continues on the next page...

Table 1. Pinout list by bus (continued)

| Signal | Signal description | Package pin number | Pin type | Power supply | Notes |
|--------|-------------------------------|--------------------|----------|--------------|-------|
| GND141 | Core, Platform and PLL Ground | U18 | --- | --- | --- |
| GND142 | Core, Platform and PLL Ground | U20 | --- | --- | --- |
| GND143 | Core, Platform and PLL Ground | U23 | --- | --- | --- |
| GND144 | Core, Platform and PLL Ground | V2 | --- | --- | --- |
| GND145 | Core, Platform and PLL Ground | V4 | --- | --- | --- |
| GND146 | Core, Platform and PLL Ground | V6 | --- | --- | --- |
| GND147 | Core, Platform and PLL Ground | V9 | --- | --- | --- |
| GND148 | Core, Platform and PLL Ground | V11 | --- | --- | --- |
| GND149 | Core, Platform and PLL Ground | V13 | --- | --- | --- |
| GND150 | Core, Platform and PLL Ground | V15 | --- | --- | --- |
| GND151 | Core, Platform and PLL Ground | V17 | --- | --- | --- |
| GND152 | Core, Platform and PLL Ground | V19 | --- | --- | --- |
| GND153 | Core, Platform and PLL Ground | V21 | --- | --- | --- |
| GND154 | Core, Platform and PLL Ground | V23 | --- | --- | --- |
| GND155 | Core, Platform and PLL Ground | V26 | --- | --- | --- |
| GND156 | Core, Platform and PLL Ground | W12 | --- | --- | --- |
| GND157 | Core, Platform and PLL Ground | W18 | --- | --- | --- |
| GND158 | Core, Platform and PLL Ground | W20 | --- | --- | --- |
| GND159 | Core, Platform and PLL Ground | W22 | --- | --- | --- |
| GND160 | Core, Platform and PLL Ground | Y2 | --- | --- | --- |
| GND161 | Core, Platform and PLL Ground | Y21 | --- | --- | --- |
| GND162 | Core, Platform and PLL Ground | Y23 | --- | --- | --- |

Table continues on the next page...

Table 1. Pinout list by bus (continued)

| Signal | Signal description | Package pin number | Pin type | Power supply | Notes |
|----------|--|--------------------|----------|--------------|-------|
| GND163 | Core, Platform and PLL Ground | Y26 | --- | --- | --- |
| GND164 | Core, Platform and PLL Ground | AA4 | --- | --- | --- |
| GND165 | Core, Platform and PLL Ground | AA21 | --- | --- | --- |
| GND166 | Core, Platform and PLL Ground | AA24 | --- | --- | --- |
| GND167 | Core, Platform and PLL Ground | AB2 | --- | --- | --- |
| GND168 | Core, Platform and PLL Ground | AB26 | --- | --- | --- |
| GND169 | Core, Platform and PLL Ground | AC21 | --- | --- | --- |
| GND170 | Core, Platform and PLL Ground | AC24 | --- | --- | --- |
| GND171 | Core, Platform and PLL Ground | AD2 | --- | --- | --- |
| GND172 | Core, Platform and PLL Ground | AD4 | --- | --- | --- |
| GND173 | Core, Platform and PLL Ground | AD26 | --- | --- | --- |
| GND174 | Core, Platform and PLL Ground | AE21 | --- | --- | --- |
| GND175 | Core, Platform and PLL Ground | AE24 | --- | --- | --- |
| GND176 | Core, Platform and PLL Ground | AF4 | --- | --- | --- |
| GND177 | Core, Platform and PLL Ground | AF21 | --- | --- | --- |
| GND178 | Core, Platform and PLL Ground | AF26 | --- | --- | --- |
| GND179 | Core, Platform and PLL Ground | AG1 | --- | --- | --- |
| GND180 | Core, Platform and PLL Ground | AG24 | --- | --- | --- |
| GND181 | Core, Platform and PLL Ground | AG26 | --- | --- | --- |
| GND182 | Core, Platform and PLL Ground | AH2 | --- | --- | --- |
| GND183 | Core, Platform and PLL Ground | AH21 | --- | --- | --- |
| SD_GND01 | SerDes core logic, transceiver, and PLL ground | Y6 | --- | --- | 18 |

Table continues on the next page...

Table 1. Pinout list by bus (continued)

| Signal | Signal description | Package pin number | Pin type | Power supply | Notes |
|----------|--|--------------------|----------|--------------|-------|
| SD_GND02 | SerDes core logic, transceiver, and PLL ground | Y7 | --- | --- | 18 |
| SD_GND03 | SerDes core logic, transceiver, and PLL ground | Y8 | --- | --- | 18 |
| SD_GND04 | SerDes core logic, transceiver, and PLL ground | Y9 | --- | --- | 18 |
| SD_GND05 | SerDes core logic, transceiver, and PLL ground | Y10 | --- | --- | 18 |
| SD_GND06 | SerDes core logic, transceiver, and PLL ground | Y13 | --- | --- | 18 |
| SD_GND07 | SerDes core logic, transceiver, and PLL ground | Y14 | --- | --- | 18 |
| SD_GND08 | SerDes core logic, transceiver, and PLL ground | Y15 | --- | --- | 18 |
| SD_GND09 | SerDes core logic, transceiver, and PLL ground | Y16 | --- | --- | 18 |
| SD_GND10 | SerDes core logic, transceiver, and PLL ground | AA5 | --- | --- | 18 |
| SD_GND11 | SerDes core logic, transceiver, and PLL ground | AA7 | --- | --- | 18 |
| SD_GND12 | SerDes core logic, transceiver, and PLL ground | AA9 | --- | --- | 18 |
| SD_GND13 | SerDes core logic, transceiver, and PLL ground | AA12 | --- | --- | 18 |
| SD_GND14 | SerDes core logic, transceiver, and PLL ground | AA14 | --- | --- | 18 |
| SD_GND15 | SerDes core logic, transceiver, and PLL ground | AA17 | --- | --- | 18 |
| SD_GND16 | SerDes core logic, transceiver, and PLL ground | AA18 | --- | --- | 18 |
| SD_GND17 | SerDes core logic, transceiver, and PLL ground | AA19 | --- | --- | 18 |
| SD_GND18 | SerDes core logic, transceiver, and PLL ground | AB7 | --- | --- | 18 |
| SD_GND19 | SerDes core logic, transceiver, and PLL ground | AB9 | --- | --- | 18 |
| SD_GND20 | SerDes core logic, transceiver, and PLL ground | AB12 | --- | --- | 18 |
| SD_GND21 | SerDes core logic, transceiver, and PLL ground | AB14 | --- | --- | 18 |
| SD_GND22 | SerDes core logic, transceiver, and PLL ground | AB17 | --- | --- | 18 |
| SD_GND23 | SerDes core logic, transceiver, and PLL ground | AB20 | --- | --- | 18 |

Table continues on the next page...

Table 1. Pinout list by bus (continued)

| Signal | Signal description | Package pin number | Pin type | Power supply | Notes |
|----------|--|--------------------|----------|--------------|-------|
| SD_GND24 | SerDes core logic, transceiver, and PLL ground | AC5 | --- | --- | 18 |
| SD_GND25 | SerDes core logic, transceiver, and PLL ground | AC6 | --- | --- | 18 |
| SD_GND26 | SerDes core logic, transceiver, and PLL ground | AC8 | --- | --- | 18 |
| SD_GND27 | SerDes core logic, transceiver, and PLL ground | AC10 | --- | --- | 18 |
| SD_GND28 | SerDes core logic, transceiver, and PLL ground | AC11 | --- | --- | 18 |
| SD_GND29 | SerDes core logic, transceiver, and PLL ground | AC15 | --- | --- | 18 |
| SD_GND30 | SerDes core logic, transceiver, and PLL ground | AC16 | --- | --- | 18 |
| SD_GND31 | SerDes core logic, transceiver, and PLL ground | AC18 | --- | --- | 18 |
| SD_GND32 | SerDes core logic, transceiver, and PLL ground | AC19 | --- | --- | 18 |
| SD_GND33 | SerDes core logic, transceiver, and PLL ground | AD5 | --- | --- | 18 |
| SD_GND34 | SerDes core logic, transceiver, and PLL ground | AD7 | --- | --- | 18 |
| SD_GND35 | SerDes core logic, transceiver, and PLL ground | AD9 | --- | --- | 18 |
| SD_GND36 | SerDes core logic, transceiver, and PLL ground | AD12 | --- | --- | 18 |
| SD_GND37 | SerDes core logic, transceiver, and PLL ground | AD14 | --- | --- | 18 |
| SD_GND38 | SerDes core logic, transceiver, and PLL ground | AD17 | --- | --- | 18 |
| SD_GND39 | SerDes core logic, transceiver, and PLL ground | AD20 | --- | --- | 18 |
| SD_GND40 | SerDes core logic, transceiver, and PLL ground | AE5 | --- | --- | 18 |
| SD_GND41 | SerDes core logic, transceiver, and PLL ground | AE7 | --- | --- | 18 |
| SD_GND42 | SerDes core logic, transceiver, and PLL ground | AE9 | --- | --- | 18 |
| SD_GND43 | SerDes core logic, transceiver, and PLL ground | AE12 | --- | --- | 18 |
| SD_GND44 | SerDes core logic, transceiver, and PLL ground | AE14 | --- | --- | 18 |
| SD_GND45 | SerDes core logic, transceiver, and PLL ground | AE17 | --- | --- | 18 |

Table continues on the next page...

Table 1. Pinout list by bus (continued)

| Signal | Signal description | Package pin number | Pin type | Power supply | Notes |
|----------|--|--------------------|----------|--------------|-------|
| SD_GND46 | SerDes core logic, transceiver, and PLL ground | AE20 | --- | --- | 18 |
| SD_GND47 | SerDes core logic, transceiver, and PLL ground | AF6 | --- | --- | 18 |
| SD_GND48 | SerDes core logic, transceiver, and PLL ground | AF7 | --- | --- | 18 |
| SD_GND49 | SerDes core logic, transceiver, and PLL ground | AF8 | --- | --- | 18 |
| SD_GND50 | SerDes core logic, transceiver, and PLL ground | AF9 | --- | --- | 18 |
| SD_GND51 | SerDes core logic, transceiver, and PLL ground | AF10 | --- | --- | 18 |
| SD_GND52 | SerDes core logic, transceiver, and PLL ground | AF11 | --- | --- | 18 |
| SD_GND53 | SerDes core logic, transceiver, and PLL ground | AF15 | --- | --- | 18 |
| SD_GND54 | SerDes core logic, transceiver, and PLL ground | AF16 | --- | --- | 18 |
| SD_GND55 | SerDes core logic, transceiver, and PLL ground | AF17 | --- | --- | 18 |
| SD_GND56 | SerDes core logic, transceiver, and PLL ground | AF18 | --- | --- | 18 |
| SD_GND57 | SerDes core logic, transceiver, and PLL ground | AF19 | --- | --- | 18 |
| SD_GND58 | SerDes core logic, transceiver, and PLL ground | AG5 | --- | --- | 18 |
| SD_GND59 | SerDes core logic, transceiver, and PLL ground | AG7 | --- | --- | 18 |
| SD_GND60 | SerDes core logic, transceiver, and PLL ground | AG9 | --- | --- | 18 |
| SD_GND61 | SerDes core logic, transceiver, and PLL ground | AG12 | --- | --- | 18 |
| SD_GND62 | SerDes core logic, transceiver, and PLL ground | AG14 | --- | --- | 18 |
| SD_GND63 | SerDes core logic, transceiver, and PLL ground | AG17 | --- | --- | 18 |
| SD_GND64 | SerDes core logic, transceiver, and PLL ground | AG20 | --- | --- | 18 |
| SD_GND65 | SerDes core logic, transceiver, and PLL ground | AH5 | --- | --- | 18 |
| SD_GND66 | SerDes core logic, transceiver, and PLL ground | AH7 | --- | --- | 18 |
| SD_GND67 | SerDes core logic, transceiver, and PLL ground | AH9 | --- | --- | 18 |

Table continues on the next page...

Table 1. Pinout list by bus (continued)

| Signal | Signal description | Package pin number | Pin type | Power supply | Notes |
|----------|--|--------------------|----------|-------------------|-------|
| SD_GND68 | SerDes core logic, transceiver, and PLL ground | AH12 | --- | --- | 18 |
| SD_GND69 | SerDes core logic, transceiver, and PLL ground | AH14 | --- | --- | 18 |
| SD_GND70 | SerDes core logic, transceiver, and PLL ground | AH17 | --- | --- | 18 |
| SD_GND71 | SerDes core logic, transceiver, and PLL ground | AH20 | --- | --- | 18 |
| SENSEGND | Ground Sense pin | G20 | --- | --- | --- |
| OVDD1 | General I/O supply | J18 | --- | OV _{DD} | --- |
| OVDD2 | General I/O supply | K9 | --- | OV _{DD} | --- |
| OVDD3 | General I/O supply | K10 | --- | OV _{DD} | --- |
| OVDD4 | General I/O supply | K11 | --- | OV _{DD} | --- |
| OVDD5 | General I/O supply | K12 | --- | OV _{DD} | --- |
| OVDD6 | General I/O supply | R7 | --- | OV _{DD} | --- |
| DVDD1 | UART/I2C/QE supply | N7 | --- | DV _{DD} | --- |
| DVDD2 | UART/I2C/QE supply | P7 | --- | DV _{DD} | --- |
| EVDD | eSDHC supply - switchable | R6 | --- | EV _{DD} | --- |
| LVDD1 | RGMI _I supply | T7 | --- | LV _{DD} | --- |
| LVDD2 | RGMI _I supply | U7 | --- | LV _{DD} | --- |
| LVDD3 | RGMI _I supply | V7 | --- | LV _{DD} | --- |
| TVDD | 10G MDIO supply | W6 | --- | TV _{DD} | --- |
| G1VDD01 | DDR supply | B27 | --- | G1V _{DD} | --- |
| G1VDD02 | DDR supply | D27 | --- | G1V _{DD} | --- |
| G1VDD03 | DDR supply | F27 | --- | G1V _{DD} | --- |
| G1VDD04 | DDR supply | H27 | --- | G1V _{DD} | --- |
| G1VDD05 | DDR supply | K27 | --- | G1V _{DD} | --- |
| G1VDD06 | DDR supply | L22 | --- | G1V _{DD} | --- |
| G1VDD07 | DDR supply | M22 | --- | G1V _{DD} | --- |
| G1VDD08 | DDR supply | M27 | --- | G1V _{DD} | --- |
| G1VDD09 | DDR supply | N22 | --- | G1V _{DD} | --- |
| G1VDD10 | DDR supply | P22 | --- | G1V _{DD} | --- |
| G1VDD11 | DDR supply | P27 | --- | G1V _{DD} | --- |
| G1VDD12 | DDR supply | R22 | --- | G1V _{DD} | --- |
| G1VDD13 | DDR supply | T22 | --- | G1V _{DD} | --- |
| G1VDD14 | DDR supply | U22 | --- | G1V _{DD} | --- |
| G1VDD15 | DDR supply | U27 | --- | G1V _{DD} | --- |
| G1VDD16 | DDR supply | V22 | --- | G1V _{DD} | --- |
| G1VDD17 | DDR supply | W27 | --- | G1V _{DD} | --- |

Table continues on the next page...

Table 1. Pinout list by bus (continued)

| Signal | Signal description | Package pin number | Pin type | Power supply | Notes |
|-------------|--------------------------------------|--------------------|----------|--------------------|-------|
| G1VDD18 | DDR supply | AA27 | --- | G1V _{DD} | --- |
| G1VDD19 | DDR supply | AC27 | --- | G1V _{DD} | --- |
| G1VDD20 | DDR supply | AE27 | --- | G1V _{DD} | --- |
| G1VDD21 | DDR supply | AG27 | --- | G1V _{DD} | --- |
| G1VDD22 | DDR supply | AH27 | --- | G1V _{DD} | --- |
| SVDD1 | SerDes transceiver supply | W7 | --- | SV _{DD} | --- |
| SVDD2 | SerDes transceiver supply | W8 | --- | SV _{DD} | --- |
| SVDD3 | SerDes transceiver supply | W9 | --- | SV _{DD} | --- |
| SVDD4 | SerDes transceiver supply | W10 | --- | SV _{DD} | --- |
| SVDD5 | SerDes transceiver supply | W13 | --- | SV _{DD} | --- |
| SVDD6 | SerDes transceiver supply | W14 | --- | SV _{DD} | --- |
| SVDD7 | SerDes transceiver supply | W15 | --- | SV _{DD} | --- |
| SVDD8 | SerDes transceiver supply | W16 | --- | SV _{DD} | --- |
| XVDD1 | SerDes transceiver supply | AC7 | --- | XV _{DD} | --- |
| XVDD2 | SerDes transceiver supply | AC9 | --- | XV _{DD} | --- |
| XVDD3 | SerDes transceiver supply | AC12 | --- | XV _{DD} | --- |
| XVDD4 | SerDes transceiver supply | AC14 | --- | XV _{DD} | --- |
| XVDD5 | SerDes transceiver supply | AC17 | --- | XV _{DD} | --- |
| XVDD6 | SerDes transceiver supply | AC20 | --- | XV _{DD} | --- |
| FA_VL | Reserved | AB21 | --- | FA_VL | --- |
| PROG_MTR | Reserved | F13 | --- | PROG_MTR | --- |
| TA_PROG_SFP | SFP Fuse Programming Override supply | G13 | --- | TA_PROG_SFP | --- |
| TH_VDD | Thermal Monitor Unit supply | G8 | --- | TH_V _{DD} | --- |
| VDD01 | Supply for cores and platform | K14 | --- | V _{DD} | --- |
| VDD02 | Supply for cores and platform | K16 | --- | V _{DD} | --- |
| VDD03 | Supply for cores and platform | K18 | --- | V _{DD} | --- |
| VDD04 | Supply for cores and platform | K20 | --- | V _{DD} | --- |
| VDD05 | Supply for cores and platform | K22 | --- | V _{DD} | --- |
| VDD06 | Supply for cores and platform | L9 | --- | V _{DD} | --- |
| VDD07 | Supply for cores and platform | L11 | --- | V _{DD} | --- |
| VDD08 | Supply for cores and platform | L13 | --- | V _{DD} | --- |
| VDD09 | Supply for cores and platform | L15 | --- | V _{DD} | --- |
| VDD10 | Supply for cores and platform | L17 | --- | V _{DD} | --- |
| VDD11 | Supply for cores and platform | L19 | --- | V _{DD} | --- |
| VDD12 | Supply for cores and platform | L21 | --- | V _{DD} | --- |
| VDD13 | Supply for cores and platform | M10 | --- | V _{DD} | --- |
| VDD14 | Supply for cores and platform | M12 | --- | V _{DD} | --- |

Table continues on the next page...

Table 1. Pinout list by bus (continued)

| Signal | Signal description | Package pin number | Pin type | Power supply | Notes |
|--------|-------------------------------|--------------------|----------|-----------------|-------|
| VDD15 | Supply for cores and platform | M14 | --- | V _{DD} | --- |
| VDD16 | Supply for cores and platform | M16 | --- | V _{DD} | --- |
| VDD17 | Supply for cores and platform | M18 | --- | V _{DD} | --- |
| VDD18 | Supply for cores and platform | M20 | --- | V _{DD} | --- |
| VDD19 | Supply for cores and platform | N9 | --- | V _{DD} | --- |
| VDD20 | Supply for cores and platform | N11 | --- | V _{DD} | --- |
| VDD21 | Supply for cores and platform | N13 | --- | V _{DD} | --- |
| VDD22 | Supply for cores and platform | N15 | --- | V _{DD} | --- |
| VDD23 | Supply for cores and platform | N17 | --- | V _{DD} | --- |
| VDD24 | Supply for cores and platform | N19 | --- | V _{DD} | --- |
| VDD25 | Supply for cores and platform | N21 | --- | V _{DD} | --- |
| VDD26 | Supply for cores and platform | P8 | --- | V _{DD} | --- |
| VDD27 | Supply for cores and platform | P10 | --- | V _{DD} | --- |
| VDD28 | Supply for cores and platform | P12 | --- | V _{DD} | --- |
| VDD29 | Supply for cores and platform | P14 | --- | V _{DD} | --- |
| VDD30 | Supply for cores and platform | P16 | --- | V _{DD} | --- |
| VDD31 | Supply for cores and platform | P18 | --- | V _{DD} | --- |
| VDD32 | Supply for cores and platform | P20 | --- | V _{DD} | --- |
| VDD33 | Supply for cores and platform | R9 | --- | V _{DD} | --- |
| VDD34 | Supply for cores and platform | R11 | --- | V _{DD} | --- |
| VDD35 | Supply for cores and platform | R13 | --- | V _{DD} | --- |
| VDD36 | Supply for cores and platform | R15 | --- | V _{DD} | --- |
| VDD37 | Supply for cores and platform | R17 | --- | V _{DD} | --- |
| VDD38 | Supply for cores and platform | R19 | --- | V _{DD} | --- |
| VDD39 | Supply for cores and platform | T8 | --- | V _{DD} | --- |
| VDD40 | Supply for cores and platform | T10 | --- | V _{DD} | --- |
| VDD41 | Supply for cores and platform | T12 | --- | V _{DD} | --- |
| VDD42 | Supply for cores and platform | T14 | --- | V _{DD} | --- |
| VDD43 | Supply for cores and platform | T16 | --- | V _{DD} | --- |
| VDD44 | Supply for cores and platform | T18 | --- | V _{DD} | --- |
| VDD45 | Supply for cores and platform | T20 | --- | V _{DD} | --- |
| VDD46 | Supply for cores and platform | U9 | --- | V _{DD} | --- |
| VDD47 | Supply for cores and platform | U11 | --- | V _{DD} | --- |
| VDD48 | Supply for cores and platform | U13 | --- | V _{DD} | --- |
| VDD49 | Supply for cores and platform | U15 | --- | V _{DD} | --- |
| VDD50 | Supply for cores and platform | U17 | --- | V _{DD} | --- |
| VDD51 | Supply for cores and platform | U19 | --- | V _{DD} | --- |
| VDD52 | Supply for cores and platform | U21 | --- | V _{DD} | --- |

Table continues on the next page...

Table 1. Pinout list by bus (continued)

| Signal | Signal description | Package pin number | Pin type | Power supply | Notes |
|---------------------------|--|--------------------|----------|-----------------------|-------|
| VDD53 | Supply for cores and platform | V8 | --- | V _{DD} | --- |
| VDD54 | Supply for cores and platform | V10 | --- | V _{DD} | --- |
| VDD55 | Supply for cores and platform | V12 | --- | V _{DD} | --- |
| VDD56 | Supply for cores and platform | V14 | --- | V _{DD} | --- |
| VDD57 | Supply for cores and platform | V16 | --- | V _{DD} | --- |
| VDD58 | Supply for cores and platform | V18 | --- | V _{DD} | --- |
| VDD59 | Supply for cores and platform | V20 | --- | V _{DD} | --- |
| VDD60 | Supply for cores and platform | W11 | --- | V _{DD} | --- |
| VDD61 | Supply for cores and platform | W17 | --- | V _{DD} | --- |
| VDD62 | Supply for cores and platform | W19 | --- | V _{DD} | --- |
| VDD63 | Supply for cores and platform | W21 | --- | V _{DD} | --- |
| TA_BB_VDD | Battery Backed Security Monitor supply | G12 | --- | TA_BB_V _{DD} | --- |
| AVDD_CGA1 | CPU Cluster Group A PLL1 supply | H11 | --- | AVDD_CGA1 | --- |
| AVDD_CGA2 | CPU Cluster Group A PLL1 supply | H10 | --- | AVDD_CGA2 | --- |
| AVDD_PLAT | Platform PLL supply | H9 | --- | AVDD_PLAT | --- |
| AVDD_D1 | DDR1 PLL supply | R21 | --- | AVDD_D1 | --- |
| AVDD_SD1_PLL1 | SerDes1 PLL 1 supply | AA11 | --- | AVDD_SD1_PLL1 | --- |
| AVDD_SD1_PLL2 | SerDes1 PLL 2 supply | AB6 | --- | AVDD_SD1_PLL2 | --- |
| AVDD_SD2_PLL1 | SerDes2 PLL 1 supply | AB15 | --- | AVDD_SD2_PLL1 | --- |
| AVDD_SD2_PLL2 | SerDes2 PLL 2 supply | AA16 | --- | AVDD_SD2_PLL2 | --- |
| SENSEVDD | Vdd Sense pin | G19 | --- | SENSEVDD | --- |
| USB_HVDD1 | USB PHY 3.3V High Supply | K8 | --- | USB_HV _{DD} | --- |
| USB_HVDD2 | USB PHY 3.3V High Supply | L8 | --- | USB_HV _{DD} | --- |
| USB_SDVDD1 | USB PHY 1.0 V Analog and digital SS supply | M7 | --- | USB_SDV _{DD} | --- |
| USB_SDVDD2 | USB PHY 1.0 V Analog and digital SS supply | M8 | --- | USB_SDV _{DD} | --- |
| USB_SVDD1 | USB PHY 1.0 V Analog and digital HS supply | K7 | --- | USB_SV _{DD} | --- |
| USB_SVDD2 | USB PHY 1.0 V Analog and digital HS supply | L7 | --- | USB_SV _{DD} | --- |
| No Connection Pins | | | | | |
| NC_A3 | No Connection | A3 | --- | --- | 12 |
| NC_A4 | No Connection | A4 | --- | --- | 12 |
| NC_A6 | No Connection | A6 | --- | --- | 12 |
| NC_A7 | No Connection | A7 | --- | --- | 12 |
| NC_AA10 | No Connection | AA10 | --- | --- | 12 |

Table continues on the next page...

Table 1. Pinout list by bus (continued)

| Signal | Signal description | Package pin number | Pin type | Power supply | Notes |
|---------|--------------------|--------------------|----------|--------------|-------|
| NC_AA15 | No Connection | AA15 | --- | --- | 12 |
| NC_AB10 | No Connection | AB10 | --- | --- | 12 |
| NC_AB11 | No Connection | AB11 | --- | --- | 12 |
| NC_AB16 | No Connection | AB16 | --- | --- | 12 |
| NC_B1 | No Connection | B1 | --- | --- | 12 |
| NC_B2 | No Connection | B2 | --- | --- | 12 |
| NC_B5 | No Connection | B5 | --- | --- | 12 |
| NC_B6 | No Connection | B6 | --- | --- | 12 |
| NC_G5 | No Connection | G5 | --- | --- | 12 |
| NC_J14 | No Connection | J14 | --- | --- | 12 |
| NC_J15 | No Connection | J15 | --- | --- | 12 |
| NC_J16 | No Connection | J16 | --- | --- | 12 |
| NC_J17 | No Connection | J17 | --- | --- | 12 |
| NC_P21 | No Connection | P21 | --- | --- | 12 |
| NC_P5 | No Connection | P5 | --- | --- | 12 |
| NC_R4 | No Connection | R4 | --- | --- | 12 |
| NC_T5 | No Connection | T5 | --- | --- | 12 |
| NC_U4 | No Connection | U4 | --- | --- | 12 |
| NC_U5 | No Connection | U5 | --- | --- | 12 |
| NC_V5 | No Connection | V5 | --- | --- | 12 |
| NC_W5 | No Connection | W5 | --- | --- | 12 |
| NC_Y17 | No Connection | Y17 | --- | --- | 12 |
| NC_Y18 | No Connection | Y18 | --- | --- | 12 |
| NC_Y19 | No Connection | Y19 | --- | --- | 12 |
| NC_Y5 | No Connection | Y5 | --- | --- | 12 |
| NC_F12 | No Connection | F12 | --- | --- | 12 |

1. Functionally, this pin is an output or an input, but structurally it is an I/O because it either samples configuration input during reset, is a muxed pin, or has other manufacturing test functions. Therefore, this pin is described as an I/O for boundary scan.
2. This output is actively driven during reset rather than being tri-stated during reset.
3. MDIC[0] is grounded through a 162 Ω precision 1% resistor and MDIC[1] is connected to GV_{DD} through a 162 Ω precision 1% resistor. For either full or half driver strength calibration of DDR I/Os, use the same MDIC resistor value of 162 Ω . The memory controller register setting can be used to determine automatic calibration is done to full or half drive strength. These pins are used for automatic calibration of the DDR4 I/Os.

Pin assignments

4. This pin is a reset configuration pin. It has a weak ($\sim 20\text{ k}\Omega$) internal pull-up P-FET that is enabled only when the processor is in its reset state. This pull-up is designed such that it can be overpowered by an external $4.7\text{ k}\Omega$ resistor. However, if the signal is intended to be high after reset, and if there is any device on the net that might pull down the value of the net at reset, a pull-up or active driver is needed.
5. Pin must **NOT** be pulled down during power-on reset. This pin may be pulled up, driven high, or, if there are any externally connected devices, left in tristate. If this pin is connected to a device that pulls down during reset, an external pull-up is required to drive this pin to a safe state during reset.
6. Recommend that a weak pull-up resistor ($2\text{-}10\text{ k}\Omega$) be placed on this pin to the respective power supply.
7. This pin is an open-drain signal.
8. Recommend that a pull-up resistor ($1\text{ k}\Omega$) be placed on this pin to the respective power supply.
9. This pin has a weak ($\sim 20\text{ k}\Omega$) internal pull-up P-FET that is always enabled.
10. These are test signals for factory use only and must be pulled up ($100\ \Omega$ to $1\text{ k}\Omega$) to the respective power supply for normal operation.
11. This pin requires a $200\ \Omega$ pull-up to the respective power supply.
12. Do not connect. These pins should be left floating.
13. These pins must be pulled up to TV_{DD} through a $180\ \Omega \pm 1\%$ resistor for MDC and a $330\ \Omega \pm 1\%$ resistor for MDIO.
14. This pin requires an external $1\text{ k}\Omega$ pull-down resistor to prevent PHY from seeing a valid Transmit Enable before it is actively driven.
15. These pins must be pulled to ground (GND).
16. This pin requires a $698\ \Omega$ pull-up to the respective power supply.
17. These pins should be tied to ground if the diode is not utilized for temperature monitoring.
18. SD_GND must be directly connected to GND.
19. For proper clock selection, terminate `cfg_eng_use0` with a pull up or pull down of $4.7\text{ k}\Omega$ to ensure that the signal will have a valid state as soon as the IO voltage reaches its operating condition.

20. DIFF_SYSCLK and DIFF_SYSCLK_B is tied to cfg_eng_use0, the configuration is described in section "Reset Configuration Word (RCW)" of *QorIQ LS1088A Reference Manual*.

Warning

See "**Connection Recommendations**" for additional details on properly connecting these pins for specific applications.

3 Electrical characteristics

This section describes the DC and AC electrical specifications for the chip. The chip is currently targeted to these specifications, some of which are independent of the I/O cell but are included for a more complete reference. These are not purely I/O buffer design specifications.

3.1 Overall DC electrical characteristics

This section describes the ratings, conditions, and other characteristics.

3.1.1 Absolute maximum ratings

This table provides the absolute maximum ratings.

Table 2. Absolute maximum ratings¹

| Characteristic | Symbol | Min | Max | Unit | Notes |
|---|--|------|------|------|-------|
| Core and platform supply voltage | V _{DD} | -0.3 | 1.1 | V | 8 |
| PLL supply voltage (core PLL, platform, DDR) | AV _{DD} _CGA1, AV _{DD} _CGA2, AV _{DD} _PLAT, AV _{DD} _D1 | -0.3 | 1.98 | V | — |
| PLL supply voltage (SerDes, filtered from XV _{DD}) | AVDD_SDn_PLL1 AVDD_SDn_PLL2 | -0.3 | 1.48 | V | — |
| SFP Fuse Programming | TA_PROG_SFP | -0.3 | 1.98 | V | — |
| Thermal Unit Monitor supply | TH_V _{DD} | -0.3 | 1.98 | V | — |
| IFC, SPI, GIC (IRQ 0/1/2), Tamper_Detect, System control and power management, SYSCLK, DDR_CLK, GPIO1, GPIO2, GPIO3, eSDHC[4-7]/VS/DAT123_DIR/DAT0_DIR/CMD_DIR/SYNC), Debug, JTAG, RTC, POR signals | OV _{DD} | -0.3 | 1.98 | V | — |

Table continues on the next page...

Table 2. Absolute maximum ratings¹ (continued)

| Characteristic | | Symbol | Min | Max | Unit | Notes |
|--|---|-----------------------|------|----------------------------------|------|---------|
| DUART1/2, I ² C, DMA, QE, GPIO3, GPIO4, GIC (IRQ 3/4/5/6/7/8/9/10), USB control (DRVVBUS, PWRFAULT) | | DV _{DD} | -0.3 | 3.63; 1.98 | V | 9 |
| eSDHC[0-3]/CLK/CMD, GPIO3 | | EV _{DD} | -0.3 | 3.63; 1.98 | V | — |
| DDR4 DRAM I/O voltage | | G1V _{DD} | -0.3 | 1.32 | V | — |
| Main power supply for internal circuitry of SerDes and pad power supply for SerDes receivers and DIFF_SYSCLK | | SV _{DD} | -0.3 | 1.1 | V | — |
| Pad power supply for SerDes transmitter | | XV _{DD} | -0.3 | 1.48 | V | — |
| Ethernet interface 1/2, Ethernet management interface 1 (EMI1), TSEC_1588, GPIO2, GPIO4, GIC (IRQ11) | | LV _{DD} | -0.3 | 2.75; 1.98 | V | — |
| Ethernet management interface 2 (EMI2), GPIO2 | | TV _{DD} | -0.3 | 2.75; 1.98; 1.32 | V | — |
| USB PHY Transceiver supply voltage | | USB_HV _{DD} | -0.3 | 3.63 | V | 10 |
| | | USB_SDV _{DD} | -0.3 | 1.1 | V | 11 |
| | | USB_SV _{DD} | -0.3 | 1.1 | V | 12 |
| Battery Backed Security Monitor supply | | TA_BB_V _{DD} | -0.3 | 1.1 | V | — |
| Input voltage | DDR4 DRAM signals | MV _{IN} | -0.3 | G1V _{DD} + 0.3 | V | 2 |
| | SerDes interface and DIFF_SYSCLK | SV _{IN} | -0.3 | -0.3 to (SV _{DD} + 0.3) | V | 5 |
| | Ethernet interface 1/2, Ethernet management interface 1 (EMI1), TSEC_1588, GPIO2, GPIO4, GIC (IRQ11) | LV _{IN} | -0.3 | LV _{DD} + 0.3 | V | 4, 5 |
| | IFC, SPI, GIC (IRQ 0/1/2), Tamper_Detect, System control and power management, SYSCLK, DDR_CLK, GPIO3, GPIO2, GPIO1, eSDHC[4-7]/VS/DAT123_DIR/DAT0_DIR/CMD_DIR/SYNC), Debug, JTAG, RTC, POR signals | OV _{IN} | -0.3 | OV _{DD} + 0.3 | V | 3, 5 |
| | eSDHC[0-3]/CLK/CMD, GPIO3 | EV _{IN} | -0.3 | EV _{DD} + 0.3 | V | 5, 6, 7 |
| | DUART1/2, I ² C, DMA, QE, GPIO3, GPIO4, GIC (IRQ | DV _{IN} | -0.3 | DV _{DD} + 0.3 | V | 5, 6, 9 |

Table continues on the next page...

Table 2. Absolute maximum ratings¹ (continued)

| Characteristic | | Symbol | Min | Max | Unit | Notes |
|------------------------------------|--|-----------------------|------|-----------------------------|------|-------|
| USB PHY transceiver supply voltage | 3/4/5/6/7/8/9/10), USB control (DRVVBUS, PWRFAULT) | | | | | |
| | Ethernet management interface 2 (EMI2), GPIO2 | TV _{IN} | -0.3 | TV _{DD} + 0.3 | V | 13 |
| | Transceiver supply for USB PHY | USB_HV _{IN} | -0.3 | USB_HV _D + 0.3 | V | 10 |
| | Analog and Digital HS supply for USB PHY | USB_SDV _{DD} | -0.3 | USB_SDV _{DD} + 0.3 | V | 11 |
| | Analog and Digital SS supply for USB PHY | USB_SV _{DD} | -0.3 | USB_SV _D + 0.3 | V | 12 |
| Storage temperature range | T _{STG} | -55 | 150 | °C | -- | |

Notes:

- Functional operating conditions are given in [Table 3](#). Absolute maximum ratings are stress ratings only, and functional operation at the maximums is not guaranteed. Stresses beyond those listed may affect device reliability or cause permanent damage to the device.
- Caution:** MV_{IN} must not exceed GV_{DD} by more than 0.3 V. This limit may be exceeded for a maximum of 20 ms during power-on reset and power-down sequences.
- Caution:** OV_{IN} must not exceed OV_{DD} by more than 0.3 V. This limit may be exceeded for a maximum of 20 ms during power-on reset and power-down sequences.
- Caution:** LV_{IN} must not exceed LV_{DD} by more than 0.3 V. This limit may be exceeded for a maximum of 20 ms during power-on reset and power-down sequences.
- (D, G1, L, O, X, S, T, E)V_{IN} and USBn_HV_{IN} may overshoot/undershoot to a voltage and for a maximum duration as shown in [Figure 7](#).
- Caution:** DV_{IN} must not exceed DV_{DD} by more than 0.3 V. This limit may be exceeded for a maximum of 20 ms during power-on reset and power-down sequences.
- Caution:** EV_{IN} must not exceed EV_{DD} by more than 0.3 V. This limit may be exceeded for a maximum of 20 ms during power-on reset and power-down sequences.
- Supply voltage specified at the voltage sense pin. Voltage input pins should be regulated to provide specified voltage at the sense pin.
- See the power supply column to determine which power supply rail is used for each interface.
- Transceiver supply for USB PHY.
- Analog and Digital SS supply for USB PHY.
- Analog and Digital HS supply for USB PHY.
- Caution:** TV_{IN} must not exceed TV_{DD} by more than 0.3 V. This limit may be exceeded for a maximum of 20 ms during power-on reset and power-down sequences.

3.1.2 Recommended operating conditions

This table provides the recommended operating conditions for this chip.

NOTE

The values shown are the recommended operating conditions and proper device operation outside these conditions is not guaranteed.

Table 3. Recommended operating conditions

| Characteristic | Symbol | Recommended value | Unit | Notes |
|---|--|----------------------------------|------|------------|
| VID core and platform supply voltage at initial start up | V _{DD} | 1.025 V ± 30 mV | V | 3, 4, 5, 9 |
| VID core and platform supply voltage during normal operation | | VID ± 30 mV | V | 3, 4, 5, 9 |
| 0.9V core and platform supply voltage | | 0.9 V ± 30 mV | V | 4, 5, 9 |
| 0.9V core and platform supply voltage at initial start up | | 1.025 V ± 30 mV or 0.9 V ± 30 mV | V | 4, 5, 9 |
| Battery backed security monitor supply (TA_BB_TMP_DETECT_B) | TA_BB_V _{DD} | 1.0 V + 50 mV / - 30 mV | V | 9 |
| | | 0.9 V + 50 mV / - 30 mV | V | 9 |
| PLL supply voltage (core PLL, platform, DDR) | AV _{DD} _CGA1, AV _{DD} _CGA2, AV _{DD} _PLAT, AV _{DD} _D1 | 1.8 V ± 90 mV | V | — |
| PLL supply voltage (SerDes, filtered from XV _{DD}) | AV _{DD} _SD _n _PLL1 AV _{DD} _SD _n _PLL2 | 1.35 V ± 67 mV | V | — |
| SFP fuse programming | TA_PROG_SFP | 1.8 V ± 90 mV | V | 2 |
| Thermal monitor unit supply | TH_V _{DD} | 1.8 V ± 90 mV | V | — |
| IFC, SPI, GIC (IRQ 0/1/2), Tamper_Detect, System control and power management, SYSCLK, DDR_CLK, GPIO3, GPIO2, GPIO1, eSDHC[4-7]/VS/DAT123_DIR/DAT0_DIR/CMD_DIR/SYNC), Debug, JTAG, RTC, POR signals | OV _{DD} | 1.8 V ± 90 mV | V | — |
| DUART1/2, I ² C, DMA, QE, GPIO3, GPIO4, GIC (IRQ 3/4/5/6/7/8/9/10), USB control (DRVVBUS, PWRFAULT) | DV _{DD} | 3.3 V ± 165 mV 1.8 V ± 90 mV | V | 6 |
| eSDHC[0-3]/CLK/CMD, GPIO3 | EV _{DD} | 3.3 V ± 165 mV 1.8 V ± 90 mV | V | — |
| DDR4 DRAM I/O voltage | G1V _{DD} | 1.2V ± 60 mV | V | — |
| Main power supply for internal circuitry of SerDes and pad power supply for SerDes receivers and DIFF_SYSCLK | SV _{DD} | 1.0 V + 50 mV / - 30 mV | V | 9 |
| | | 0.9V + 50 mV / - 30 mV | V | 9 |
| Pad power supply for SerDes transmitters | XV _{DD} | 1.35 V ± 67 mV | V | — |
| Ethernet interface 1/2, Ethernet management interface 1 (EMI1), TSEC_1588, GPIO2, GPIO4, GIC (IRQ11) | LV _{DD} | 2.5 V ± 125 mV | V | 1 |
| | | 1.8 V ± 90 mV | | |
| Ethernet management interface 2 (EMI2), GPIO2 | TV _{DD} | 2.5 V ± 125 mV | V | — |
| | | 1.8 V ± 90 mV | | |
| | | 1.2V ± 60 mV | | |
| USB PHY 3.3 V high supply voltage | USB_HV _{DD} | 3.3 V ± 165 mV | V | 6 |

Table continues on the next page...

Table 3. Recommended operating conditions (continued)

| Characteristic | | Symbol | Recommended value | Unit | Notes |
|--------------------------------------|---|-----------------------|-------------------------------|------|-------|
| USB PHY analog and digital HS supply | | USB_SDV _{DD} | 1.0 + 50 mV / - 30 mV | V | 7, 9 |
| | | | 0.9 V + 50 mV / - 30 mV | V | 7, 9 |
| USB PHY analog and digital SS supply | | USB_SV _{DD} | 1.0 + 50 mV / - 30 mV | V | 8, 9 |
| | | | 0.9 V + 50 mV / - 30 mV | V | 8, 9 |
| Input voltage | DDR4 DRAM signals | MV _{IN} | GND to G1V _{DD} | V | — |
| | Ethernet interface 1/2, Ethernet management interface 1 (EMI1), TSEC_1588, GPIO2, GPIO4, GIC (IRQ11) | LV _{IN} | GND to LV _{DD} | V | — |
| | IFC, SPI, GIC (IRQ 0/1/2), Tamper_Detect, System control and power management, SYSCLK, DDR_CLK, GPIO3, GPIO2, GPIO1, eSDHC[4-7]/VS/DAT123_DIR/DAT0_DIR/CMD_DIR/SYNC), Debug, JTAG, RTC, POR signals | OV _{IN} | GND to OV _{DD} | V | — |
| | DUART1/2, I ² C, DMA, QE, GPIO3, GPIO4, GIC (IRQ 3/4/5/6/7/8/9/10), USB Control (DRVVBUS, PWRFAULT) | DV _{IN} | GND to DV _{DD} | V | — |
| | eSDHC[0-3]/CLK/CMD, GPIO3 | EV _{IN} | GND to EV _{DD} | V | — |
| | Main power supply for internal circuitry of SerDes and DIFF_SYSCLK | SV _{IN} | GND to SV _{DD} | V | — |
| | Ethernet management interface 2 (EMI2), GPIO2 | TV _{IN} | GND to TV _{DD} | V | — |
| PHY transceiver signals | USB transceiver supply for USB PHY | USB_HV _{IN} | GND to USB_HV _{DD} | V | 6 |
| | Analog and digital SS supply for USB PHY | USB_SDV _{DD} | GND to USB_SDV _{DD} | V | 7 |
| | Analog and digital HS supply for USB PHY | USB_SV _{DD} | 0.3 to USB_SV _{DD} | V | 8 |
| Operating temperature range | Normal operation | T _A , | T _A = 0 (min) to | °C | — |
| | | T _J | T _J = 105 (max) | | |
| | Extended temperature | T _A , | T _A = -40 (min) to | °C | — |
| | | T _J | T _J = 105 (max) | | |
| | Secure boot fuse programming | T _A , | T _A = 0 (min) to | °C | 2 |
| | | T _J | T _J = 105 (max) | | |

Notes:

1. RGMII is supported at 2.5 V or 1.8 V.
2. TA_PROG_SFP must be supplied 1.8 V and the chip must operate in the specified fuse programming temperature range only during secure boot fuse programming, subject to the power sequencing constraints shown in [Power sequencing](#). For all other operating conditions, TA_PROG_SFP must be tied to GND.
3. For additional information, see the Core and platform supply voltage filtering section in the chip design checklist.

Table 3. Recommended operating conditions

| Characteristic | Symbol | Recommended value | Unit | Notes |
|---|--------|-------------------|------|-------|
| 4. Supply voltage specified at the voltage sense pin. Voltage input pins should be regulated to provide specified voltage at the sense pin. | | | | |
| 5. Operation at 1.1 V is allowable for up to 25 ms at initial power on. | | | | |
| 6. Transceiver supply for USB PHY. | | | | |
| 7. Analog and Digital SS supply for USB PHY. | | | | |
| 8. Analog and Digital HS supply for USB PHY. | | | | |
| 9. For supported voltage requirement for a given part number, contact your NXP sales representative. | | | | |

This figure shows the undershoot and overshoot voltages at the interfaces of the chip.



Notes:

The overshoot/undershoot period should be less than 10% of shortest possible toggling period of the input signal or per input signal specific protocol requirement. For GPIO input signal overshoot/undershoot period, it should be less than 10% of the SYSCLK period.

Figure 7. Overshoot/Undershoot voltage for $G1V_{DD}/OV_{DD}/S1V_{DD}/DV_{DD}/TV_{DD}/LV_{DD}/EV_{DD}/USB*V_{DD}$

See [Table 3](#) for actual recommended core voltage. Voltage to the processor interface I/Os are provided through separate sets of supply pins and must be provided at the voltages shown in [Table 3](#). The input voltage threshold scales with respect to the associated I/O supply voltage. DVDD-, OVDD-, and LVDD-based receivers are simple CMOS I/O circuits and satisfy appropriate LVCMOS type specifications. The DDR SDRAM

interface uses differential receivers referenced by the internally generated MVREF signal. The DDR DQS receivers cannot be operated in single-ended fashion. The complement signal must be properly driven and cannot be grounded.

3.1.3 Output driver characteristics

This chip provides information on the characteristics of the output driver strengths.

NOTE

These values are preliminary estimates.

Table 4. Output drive capability

| Driver type | Output impedance (Ω) | | | Supply Voltage | Notes |
|---|-------------------------------|--|----------------------|---------------------------|-------|
| | Minimum ² | Typical | Maximum ³ | | |
| DDR4 signal | - | 18 (full-strength mode) 27 (half-strength mode) | - | G1V _{DD} = 1.2 V | 1 |
| Ethernet interface 1/2, Ethernet management interface 1 (EMI1), TSEC_1588, GPIO2, GPIO4, GIC (IRQ11) | 30 | 50 | 70 | LV _{DD} = 2.5 V | - |
| | 30 | 45 | 60 | LV _{DD} = 1.8 V | - |
| MDC of Ethernet management interface 2 (EMI 2) | 45 | 65 | 100 | TV _{DD} = 1.2 V | - |
| | 40 | 55 | 75 | TV _{DD} = 1.8 V | - |
| | 40 | 60 | 90 | TV _{DD} = 2.5 V | - |
| MDIO of Ethernet management interface 2 (EMI 2) | 30 | 40 | 60 | TV _{DD} = 1.2 V | - |
| | 25 | 33 | 44 | TV _{DD} = 1.8 V | - |
| | 25 | 40 | 57 | TV _{DD} = 2.5 V | - |
| IFC, SPI, GIC (IRQ 0/1/2), Tamper_Detect, System control and power management, DDR_CLK, GPIO1, GPIO2, GPIO3, eSDHC[4-7]/VS/DAT123_DIR/DAT0_DIR/CMD_DIR/SYNC), Debug, JTAG, RTC, POR signals | 30 | 45 | 60 | OV _{DD} = 1.8 V | - |
| DUART1/2, I ² C, DMA, QE, GPIO3, GPIO4, GIC (IRQ 3/4/5/6/7/8/9/10), USB control (DRVVBUS, PWRFAULT) | 45 | 65 | 90 | DV _{DD} = 3.3 V | - |
| | 40 | 55 | 75 | DV _{DD} = 1.8 V | - |
| eSDHC[0-3]/CLK/CMD, GPIO3 | 45 | 65 | 90 | EV _{DD} = 3.3 V | - |
| | 40 | 55 | 75 | EV _{DD} = 1.8 V | - |

1. The drive strength of the DDR4 interface in half-strength mode is at T_j = 105°C and at G1V_{DD} (min).
2. Estimated number based on best case processed device.
3. Estimated number based on worst case processed device.

3.2 General AC timing specifications

This table provides AC timing specifications for the sections not covered under the specific interface sections.

Table 5. AC Timing specifications

| Parameter | Symbol | Min | Max | Unit | Notes |
|--|-----------|-----|-----|------|-------|
| Input signal rise and fall times | t_R/t_F | - | 5 | ns | 1 |
| 1. Rise time refers to signal transitions from 10% to 90% of Supply; fall time refers to transitions from 90% to 10% of supply | | | | | |

3.3 Power sequencing

The chip requires that its power rails be applied in a specific sequence in order to ensure proper device operation. For power up, these requirements are as follows:

1. $AV_{DD_SDn_PLL1}$, $AV_{DD_SDn_PLL2}$, EV_{DD} , DV_{DD} , LV_{DD} , OV_{DD} , SV_{DD} , TV_{DD} , XV_{DD} , USB_HV_{DD} , USB_SDV_{DD} , USB_SV_{DD} . Drive $TA_PROG_SFP = GND$.
 - $PORESET_B$ input must be driven asserted and held during this step.
2. V_{DD} .
3. $G1V_{DD}$.

Items on the same line have no ordering requirement with respect to one another. Items on separate lines must be ordered sequentially such that voltage rails on a previous step must reach 90% of their value before the voltage rails on the current step reach 10% of their value. XV_{DD} , $AV_{DD_SDn_PLL1}$, and $AV_{DD_SDn_PLL2}$ have no ordering requirement to any other supplies, and they can ramp up in any step. SV_{DD} should ramp up before V_{DD} . Alternatively, V_{DD} may ramp up together with SV_{DD} provided that the relative timing between SV_{DD} and V_{DD} ramp up conforms to [Figure 8](#) below.

All supplies must be at their stable values within 400 ms.

Negate $PORESET_B$ input when the required assertion/hold time has been met per [RESET initialization timing specifications](#).

NOTE

- While V_{DD} is ramping up, leakage current might occur from V_{DD} through LS1088A to $G1V_{DD}$.
- Ensure that $SYSCLK$ is available as soon as power ramps up.
- Ramp rate requirements should be met per [Table 11](#).

NOTE

If using Trust Architecture Security Monity battery backed features, prior to V_{DD} or SV_{DD} ramping up to 0.5 V level, ensure that OV_{DD} is properly ramped to at least 90% and $SYSCLK$ or $DIFF_SYSCLK / DIFF_SYSCLK_B$ is running. The clock should have a minimum frequency of 800 Hz and a maximum frequency no greater than the supported system clock frequency for the device.

Warning

Only 300,000 POR cycles are permitted per lifetime of a device. Note that this value is based on design estimates and is preliminary.

This figure shows the SV_{DD} and V_{DD} ramp-up diagram.



Figure 8. SV_{DD} and V_{DD} ramp-up diagram

For secure boot fuse programming, use the following steps:

1. After negation of $PORESET_B$, drive $TA_PROG_SFP = 1.80$ V after a required minimum delay per [Table 6](#).

- After fuse programming is completed, it is required to return TA_PROG_SFP = GND before the system is power cycled (PORESET_B assertion) or powered down (V_{DD} ramp down) per the required timing specified in Table 6. See Security fuse processor for additional details.

Warning

No activity other than that required for secure boot fuse programming is permitted while TA_PROG_SFP is driven to any voltage above GND, including the reading of the fuse block. The reading of the fuse block may only occur while TA_PROG_SFP = GND.

This figure shows the TA_PROG_SFP timing diagram.



NOTE: TA_PROG_SFP must be stable at 1.8 V prior to initiating fuse programming.

Figure 9. TA_PROG_SFP timing diagram

This table provides information on the power-down and power-up sequence parameters for TA_PROG_SFP.

Table 6. TA_PROG_SFP timing ⁵

| Driver type | Min | Max | Unit | Notes |
|--------------------------------|-----|-----|---------|-------|
| t _{TA_PROG_SFP_DELAY} | 100 | — | SYSCLKs | 1 |
| t _{TA_PROG_SFP_PROG} | 0 | — | us | 2 |
| t _{TA_PROG_SFP_VDD} | 0 | — | us | 3 |
| t _{TA_PROG_SFP_RST} | 0 | — | us | 4 |

Notes:

- Delay required from the deassertion of PORESET_B to driving TA_PROG_SFP ramp up. Delay measured from PORESET_B deassertion at 90% OV_{DD} to 10% TA_PROG_SFP ramp up.
- Delay required from fuse programming completion to TA_PROG_SFP ramp down start. Fuse programming must complete while TA_PROG_SFP is stable at 1.8 V. No activity other than that required for secure boot fuse programming is permitted while TA_PROG_SFP is driven to any voltage above GND, including the reading of the fuse block. The reading of the fuse block may only occur while TA_PROG_SFP = GND. After fuse programming is complete, it is required to return TA_PROG_SFP = GND.

Table 6. TA_PROG_SFP timing ⁵

| Driver type | Min | Max | Unit | Notes |
|--|-----|-----|------|-------|
| 3. Delay required from TA_PROG_SFP ramp-down complete to V _{DD} ramp-down start. TA_PROG_SFP must be grounded to minimum 10% TA_PROG_SFP before V _{DD} reaches 90% V _{DD} . | | | | |
| 4. Delay required from TA_PROG_SFP ramp-down complete to PORESET_B assertion. TA_PROG_SFP must be grounded to minimum 10% TA_PROG_SFP before PORESET_B assertion reaches 90% OV _{DD} . | | | | |
| 5. Only two secure boot fuse programming events are permitted per lifetime of a device. | | | | |

3.4 Power-down requirements

The power-down cycle must complete such that power supply values are below 0.4 V before a new power-up cycle can be started.

If performing secure boot fuse programming per the requirements in [Power sequencing](#), it is required that TA_PROG_SFP = GND before the system is power cycled (PORESET_B assertion) or powered down (V_{DD} ramp down) per the required timing specified in [Power sequencing](#).

3.5 Power characteristics

This table shows the thermal power dissipation of the V_{DD} power supply for A53 core/platform/DDR frequency combinations.

Table 7. LS1088A VDD power dissipation for the thermal design

| A53 frequency (MHz) | Platform frequency(MHz) | Main DDR data rate (MT/s) | V _{DD} (V) | Power (W) | Notes |
|---------------------|-------------------------|---------------------------|---------------------|-----------|------------|
| 1600 | 700 | 2100 | VID | 9.6 | 1, 2, 3, 4 |
| 1400 | 600 | 1800 | VID | 7.6 | 1, 2, 3, 4 |
| 1200 | 500 | 1600 | 0.9 | 5.3 | 1, 2, 3, 4 |

Notes:

- VDD must run at VID voltage level, which is defined in FUSESR register
- Thermal power assumes Dhrystone running with activity factor of 60% (on all cores) and executing DMA on the platform at 100% activity factor. AIOP is powered but idle.
- Thermal power are based on worst-case processed device. The above powers are measured at the junction temperature of 85C.
- Refer to AN5144 "QorIQ LS1088A Design Checklist":
Section "Maximum VDD Power and IO Power" for the power supply design and regulator sizing
Section "Thermal Power" for the thermal power and thermal solution design

Table 8. LS1048A VDD power dissipation for the thermal design

| A53 frequency (MHz) | Platform frequency(MHz) | Main DDR data rate (MT/s) | V _{DD} (V) | Power (W) | Notes |
|---------------------|-------------------------|---------------------------|---------------------|-----------|------------|
| 1600 | 700 | 2100 | VID | 8.0 | 1, 2, 3, 4 |
| 1400 | 600 | 1800 | VID | 6.4 | 1, 2, 3, 4 |
| 1200 | 500 | 1600 | 0.9 | 4.5 | 1, 2, 3, 4 |

Notes:

- VDD must run at VID voltage level, which is defined in FUSES_R register
- Thermal power assumes Dhrystone running with activity factor of 70% (on all cores) and executing DMA on the platform at 100% activity factor. AIOP is powered but idle
- Thermal power are based on worst-case processed device. The above powers are measured at the junction temperature of 85C.
- Refer to AN5144 "QorIQ LS1088A Design Checklist":
Section "Maximum VDD Power and IO Power" for the power supply design and regulator sizing
Section "Thermal Power" for the thermal power and thermal solution design

Table 9. LS1084A VDD power dissipation for the thermal design

| A53 frequency (MHz) | Platform frequency(MHz) | Main DDR data rate (MT/s) | V _{DD} (V) | Power (W) | Notes |
|---------------------|-------------------------|---------------------------|---------------------|-----------|------------|
| 1600 | 700 | 2100 | VID | 9.3 | 1, 2, 3, 4 |
| 1400 | 600 | 1800 | VID | 7.4 | 1, 2, 3, 4 |
| 1200 | 500 | 1600 | 0.9 | 5.2 | 1, 2, 3, 4 |

Notes:

- VDD must run at VID voltage level, which is defined in FUSES_R register
- Thermal power assumes Dhrystone running with activity factor of 60% (on all cores) and executing DMA on the platform at 100% activity factor.
- Thermal power are based on worst-case processed device. The above powers are measured at the junction temperature of 85C.
- Refer to AN5144 "QorIQ LS1088A Design Checklist":
Section "Maximum VDD Power and IO Power" for the power supply design and regulator sizing
Section "Thermal Power" for the thermal power and thermal solution design

Table 10. LS1044A VDD power dissipation for the thermal design

| A53 frequency (MHz) | Platform frequency(MHz) | Main DDR data rate (MT/s) | V _{DD} (V) | Power (W) | Notes |
|---------------------|-------------------------|---------------------------|---------------------|-----------|------------|
| 1600 | 700 | 2100 | VID | 7.7 | 1, 2, 3, 4 |
| 1400 | 600 | 1800 | VID | 6.1 | 1, 2, 3, 4 |
| 1200 | 500 | 1600 | 0.9 | 4.3 | 1, 2, 3, 4 |

Notes:

- VDD must run at VID voltage level, which is defined in FUSES_R register

Table 10. LS1044A VDD power dissipation for the thermal design

| A53 frequency (MHz) | Platform frequency(MHz) | Main DDR data rate (MT/s) | V _{DD} (V) | Power (W) | Notes |
|--|-------------------------|---------------------------|---------------------|-----------|-------|
| 2. Thermal power assumes Dhrystone running with activity factor of 70% (on all cores) and executing DMA on the platform at 100% activity factor. | | | | | |
| 3. Thermal power are based on worst-case processed device. The above powers are measured at the junction temperature of 85C. | | | | | |
| 4. Refer to AN5144 "QorIQ LS1088A Design Checklist": Section "Maximum VDD Power and IO Power" for the power supply design and regulator sizing Section "Thermal Power" for the thermal power and thermal solution design | | | | | |

3.6 Power-on ramp rate

This section describes the AC electrical specifications for the power-on ramp rate requirements. Controlling the maximum power-on ramp rate is required to avoid excess in-rush current.

This table provides the power supply ramp rate specifications.

Table 11. Power supply ramp rate

| Parameter | Min | Max | Unit | Notes |
|---|-----|------|------|-------|
| Required ramp rate for all voltage supplies (including OV _{DD} /DV _{DD} /G1V _{DD} /SV _{DD} /XV _{DD} /LV _{DD} /EV _{DD} /TV _{DD} all core and platform V _{DD} supplies, TA_PROG_SFP, and all AV _{DD} supplies.) | --- | 25 | V/ms | 1, 2 |
| Required ramp rate for PROG_SFP | --- | 25 | V/ms | 1,2 |
| Required ramp rate for USB_HVDD | --- | 26.7 | V/ms | 1,2 |
| Notes: | | | | |
| 1. Ramp rate is specified as a linear ramp from 10% to 90%. If non-linear (for example, exponential), the maximum rate of change from 200 mV to 500 mV is the most critical as this range might falsely trigger the ESD circuitry. | | | | |
| 2. Over full recommended operating temperature range. See Table 3 . | | | | |

3.7 Input clocks

3.7.1 System clock (SYSCLK)

This section describes the system clock DC electrical characteristics and AC timing specifications.

3.7.1.1 SYCLK DC electrical characteristics

This table provides the SYCLK DC characteristics.

Table 12. SYCLK DC electrical characteristics

| Parameter | Symbol | Min | Typical | Max | Unit | Notes |
|--|----------|----------------------|---------|----------------------|---------|-------|
| Input high voltage | V_{IH} | $0.7 \times OV_{DD}$ | — | — | V | 1 |
| Input low voltage | V_{IL} | — | — | $0.3 \times OV_{DD}$ | V | 1 |
| Input capacitance | C_{IN} | — | 7 | 12 | pF | — |
| Input current ($V_{IN} = 0$ V or $V_{IN} = OV_{DD}$) | I_{IN} | — | — | ± 50 | μ A | 2 |

Notes:

- The min V_{IL} and max V_{IH} values are based on the respective min and max OV_{IN} values found in [Table 3](#).
- At recommended operating conditions with $OV_{DD} = 1.8$ V. See [Table 3](#).

3.7.1.2 SYCLK AC timing specifications

This table provides the SYCLK AC timing specifications.

Table 13. SYCLK AC timing specifications^{1, 5}

| Parameter/condition | Symbol | Min | Typ | Max | Unit | Notes |
|--|---------------------|-------|-----|-----------|------|-------|
| SYCLK frequency | f_{SYCLK} | 100.0 | — | 125/133.3 | MHz | 2, 6 |
| SYCLK cycle time | t_{SYCLK} | 7.5 | — | 10.0 | ns | 1, 2 |
| SYCLK duty cycle | t_{KHK}/t_{SYCLK} | 40 | — | 60 | % | 2 |
| SYCLK slew rate | — | 1 | — | 4 | V/ns | 3 |
| SYCLK peak period jitter | — | — | — | ± 150 | ps | — |
| SYCLK jitter phase noise at -56 dBc | — | — | — | 500 | kHz | 4 |
| AC Input Swing Limits at 1.8 V OV_{DD} | ΔV_{AC} | 1.08 | — | 1.8 | V | — |

Notes:

- Caution:** The relevant clock ratio settings must be chosen such that the resulting SYCLK frequencies do not exceed their respective maximum or minimum operating frequencies.
- Measured at the rising edge and/or the falling edge at $OV_{DD}/2$.
- Slew rate as measured from $0.35 \times OV_{DD}$ to $0.65 \times OV_{DD}$.
- Phase noise is calculated as FFT of TIE jitter.
- At recommended operating conditions with $OV_{DD} = 1.8$ V. See [Table 3](#).
- The 125 MHz max frequency is limited to parts with 1200 MHz CPU frequency. The 133 MHz max frequency can be used for parts with 1600 MHz and 1400 MHz CPU frequency.

3.7.2 Spread-spectrum sources

Spread-spectrum clock sources are an increasingly popular way to control electromagnetic interference emissions (EMI) by spreading the emitted noise to a wider spectrum and reducing the peak noise magnitude in order to meet industry and government requirements. These clock sources intentionally add long-term jitter to diffuse the EMI spectral content.

The jitter specification given in this table considers short-term (cycle-to-cycle) jitter only. The clock generator's cycle-to-cycle output jitter should meet the chip's input cycle-to-cycle jitter requirement.

Frequency modulation and spread are separate concerns; the chip is compatible with spread-spectrum sources if the recommendations listed in this table are observed.

Table 14. Spread-spectrum clock source recommendations³

| Parameter | Min | Max | Unit | Notes |
|----------------------|-----|-----|------|-------|
| Frequency modulation | — | 60 | kHz | — |
| Frequency spread | — | 1.0 | % | 1, 2 |

Notes:

1. SYSCLK frequencies that result from frequency spreading and the resulting core frequency must meet the minimum and maximum specifications given in [Table 13](#).
2. Maximum spread-spectrum frequency may not result in exceeding any maximum operating frequency of the device.
3. At recommended operating conditions with OVDD = 1.8 V. See [Table 3](#).

CAUTION

The processor's minimum and maximum SYSCLK and core/platform/DDR frequencies must not be exceeded, regardless of the type of clock source. Therefore, systems in which the processor is operated at its maximum rated core/platform/DDR frequency should use only down-spreading to avoid violating the stated limits.

3.7.3 USB 3.0 reference clock requirements

There are two options for the reference clock of USB PHY: SYSCLK or DIFF_SYSCLK/DIFF_SYSCLK_B. This table provides the additional requirements when SYSCLK or DIFF_SYSCLK/DIFF_SYSCLK_B is used as USB REFCLK. The 100 MHz reference clock is also required with the following requirements.

Table 15. USB AC timing specifications

| Parameter | Symbol | Min | Max | Unit | Notes |
|--------------------------------------|--------------------------|--------|-------|------|-------|
| Reference clock frequency-offset | F _{REF_OFFSET} | -300.0 | 300.0 | ppm | - |
| Reference clock random jitter (RMS) | J _{RMS_REF_CLK} | - | 3.0 | ps | 1, 2 |
| Reference clock deterministic jitter | DJ _{REF_CLK} | - | 150.0 | ps | 3 |
| Duty cycle | DC _{REF_CLK} | 40.0 | 60.0 | % | - |

1. 1.5 MHz to Nyquist frequency. For example, for 100 MHz reference clock, the Nyquist frequency is 50 MHz.
2. The peak-to-peak R_j specification is calculated at 14.069 times the R_{J_RMS} for 10⁻¹² BER.
3. DJ across all frequencies.

3.7.4 Real-time clock timing

The real-time clock timing (RTC) input is sampled by the platform clock. The output of the sampling latch is then used as an input to the time base unit of the core; there is no need for jitter specification. The minimum period of the RTC signal should be greater than or equal to 16x the period of the platform clock with a 50% duty cycle. There is no minimum RTC frequency; RTC pin may be grounded if not needed.

3.7.5 Gigabit Ethernet reference clock timing

This table provides the Ethernet gigabit reference clock DC electrical characteristics with LV_{DD} = 1.8 V.

Table 16. EC_n_GTX_CLK125 DC electrical characteristics (LV_{DD} = 1.8 V)¹

| Parameter | Symbol | Min | Typical | Max | Unit | Notes |
|--|-----------------|---------------------------|---------|---------------------------|------|-------|
| Input high voltage | V _{IH} | 0.7 x OV _{DD} | — | — | V | 2 |
| Input low voltage | V _{IL} | — | — | 0.3 x OV _{DD} | V | 2 |
| Input capacitance | C _{IN} | — | — | 6 | pF | — |
| Input current (V _{IN} = 0 V or V _{IN} = LV _{DD}) | I _{IN} | — | — | ± 50 | μA | 3 |

Notes:

- For recommended operating conditions, see [Table 3](#).
- The min V_{IL} and max V_{IH} values are based on the respective min and max V_{IN} values found in [Table 3](#).
- The symbol V_{IN}, in this case, represents the LV_{IN} symbol referenced in [Table 3](#).

This table provides the Ethernet gigabit reference clock DC electrical characteristics with LV_{DD} = 2.5 V.

Table 17. ECn_GTX_CLK125 DC electrical characteristics (LV_{DD} = 2.5 V)¹

| Parameter | Symbol | Min | Typical | Max | Unit | Notes |
|--|-----------------|---------------------------|---------|---------------------------|------|-------|
| Input high voltage | V _{IH} | 0.7 X LV _{DD} | — | — | V | 2 |
| Input low voltage | V _{IL} | — | — | 0.2 x LV _{DD} | V | 2 |
| Input capacitance | C _{IN} | — | — | 6 | pF | — |
| Input current (V _{IN} = 0 V or V _{IN} = LV _{DD}) | I _{IN} | — | — | ± 50 | µA | 3 |

Notes:

1. For recommended operating conditions, see [Table 3](#).
2. The min V_{IL} and max V_{IH} values are based on the respective min and max V_{IN} values found in [Table 3](#).
3. The symbol V_{IN}, in this case, represents the LV_{IN} symbol referenced in [Table 3](#).

This table provides the Ethernet gigabit reference clock AC timing specifications.

Table 18. ECn_GTX_CLK125 AC timing specifications ¹

| Parameter/Condition | Symbol | Min | Typical | Max | Unit | Notes |
|---|--|---------------|---------|---------------|------|-------|
| ECn_GTX_CLK125 frequency | f _{G125} | 125 - 100 ppm | 125 | 125 + 100 ppm | MHz | — |
| ECn_GTX_CLK125 cycle time | t _{G125} | 7.5 | 8 | 8.5 | ns | — |
| ECn_GTX_CLK125 rise and fall time LV _{DD} = 1.8 V LV _{DD} = 2.5 V | t _{G125R} /t _{G125F} | — | — | 0.54 0.75 | ns | 2 |
| ECn_GTX_CLK125 duty cycle 1000Base-T for RGMII | t _{G125H} /t _{G125} | 40 | — | 60 | % | 3 |
| ECn_GTX_CLK125 jitter | — | — | — | ± 150 | ps | 3 |

Notes:

1. At recommended operating conditions with LV_{DD} = 1.8 V ± 90mV / 2.5 V ± 125 mV. See [Table 3](#).
2. Rise times are measured from 20% of LV_{DD} to 80% of LV_{DD}. Fall times are measured from 80% of LV_{DD} to 20% of LV_{DD}.
3. ECn_GTX_CLK125 is used to generate the GTX clock for the Ethernet transmitter. See RGMII AC timing specifications for duty cycle for the 10Base-T and 100Base-T reference clocks.

3.7.6 DDR clock (DDRCLK)

This section provides the DDRCLK DC electrical characteristics and AC timing specifications.

3.7.6.1 DDRCLK DC electrical characteristics

This table provides the DDRCLK DC electrical characteristics.

Table 19. DDRCLK DC electrical characteristics³

| Parameter | Symbol | Min | Typical | Max | Unit | Notes |
|---|----------|----------------------|---------|----------------------|---------|-------|
| Input high voltage | V_{IH} | $0.7 \times OV_{DD}$ | — | — | V | 1 |
| Input low voltage | V_{IL} | — | — | $0.3 \times OV_{DD}$ | V | 1 |
| Input capacitance | C_{IN} | — | 7 | 12 | pF | — |
| Input current ($V_{IN} = 0V$ or $V_{IN} = OV_{DD}$) | I_{IN} | — | — | ± 50 | μA | 2 |

Notes:

1. The min V_{IL} and max V_{IH} values are based on the respective min and max OV_{IN} values found in [Table 3](#).
2. The symbol OV_{IN} , in this case, represents the OV_{IN} symbol referenced in [Table 3](#).
3. At recommended operating conditions with $OV_{DD} = 1.8 V$. See [Table 3](#).

3.7.6.2 DDRCLK AC timing specifications

This table provides the DDRCLK AC timing specifications.

Table 20. DDRCLK AC timing specifications⁵

| Parameter/Condition | Symbol | Min | Typ | Max | Unit | Notes |
|--|----------------------|-------|-----|-----------|------|-------|
| DDRCLK frequency | f_{DDRCLK} | 100.0 | — | 133.3 | MHz | 1, 2 |
| DDRCLK cycle time | t_{DDRCLK} | 7.5 | — | 10 | ns | 1, 2 |
| DDRCLK duty cycle | t_{KHK}/t_{DDRCLK} | 40 | — | 60 | % | 2 |
| DDRCLK slew rate | — | 1 | — | 4 | V/ns | 3 |
| DDRCLK peak period jitter | — | — | — | ± 150 | ps | — |
| DDRCLK jitter phase noise at -56 dBc | — | — | — | 500 | kHz | 4 |
| AC Input Swing Limits at 1.8 V OV_{DD} | ΔV_{AC} | 1.08 | — | 1.8 | V | — |

Notes:

1. **Caution:** The relevant clock ratio settings must be chosen such that the resulting DDRCLK frequencies do not exceed their respective maximum or minimum operating frequencies.
2. Measured at the rising edge and/or the falling edge at $OV_{DD}/2$.
3. Slew rate as measured from $0.35 \times OV_{DD}$ to $0.65 \times OV_{DD}$.
4. Phase noise is calculated as FFT of TIE jitter.
5. At recommended operating conditions with $OV_{DD} = 1.8 V$. See [Table 3](#).
6. DDRCLK pin does not provide the reference clock to DDR when chip is operated in Single Source Clocking mode.

3.7.7 Differential system clock (DIFF_SYSCLK/DIFF_SYSCLK_B) timing specifications

The single source clocking mode requires a single on-board oscillator to provide reference clock input to the differential system clock pair (DIFF_SYSCLK/DIFF_SYSCLK_B).

This differential clock pair input can provide the clock to core, platform, DDR, and SerDes1, SerDes2 PLLs, and USB PLLs.

This figure shows a receiver reference diagram of the differential system clock.



Figure 10. LVDS receiver

This section provides the differential system clock DC and AC timing specifications.

3.7.7.1 Differential system clock DC electrical characteristics

For DC electrical characteristics, see [DC-level requirements for SerDes reference clocks](#).

The differential system clock receiver's core power supply voltage requirements (SV_{DD}) are specified in [Table 3](#).

The Differential system clock can also be single-ended. For this DIFF_SYSCLK_B should be connected to $SV_{DD}/2$.

3.7.7.2 Differential system clock AC timing specifications

The DIFF_SYSCLK/DIFF_SYSCLK_B input pair supports an input clock frequency of 100 MHz.

For AC timing specifications, see [AC requirements for SerDes reference clocks](#).

Spread-spectrum clocking is not supported on differential system clock pair input.

3.7.8 Other input clocks

A description of the overall clocking of this device is available in the chip reference manual in the form of a clock subsystem block diagram. For information about the input clock requirements of functional modules sourced external of the chip, such as SerDes, Ethernet management, eSDHC, and IFC, see the specific interface section.

3.8 RESET initialization timing specifications

This table provides the AC timing specifications for the RESET initialization timing.

Table 21. RESET Initialization timing specifications

| Parameter/Condition | Min | Max | Unit | Notes |
|---|-----|-----|---------|-------|
| Required assertion time of PORESET_B after V _{DD} is stable | 1 | — | ms | 1 |
| Required input assertion time of HRESET_B | 32 | — | SYSClKs | 2, 3 |
| Maximum rise/fall time of HRESET_B | — | 10 | SYSClK | 4 |
| Maximum rise/fall time of PORESET_B | — | 1 | SYSClK | 4 |
| Input setup time for POR configs (other than cfg_eng_use0) with respect to negation of PORESET_B | 4 | — | SYSClKs | 2, 5 |
| Input hold time for all POR configs with respect to negation of PORESET_B | 2 | — | SYSClKs | 2 |
| Maximum valid-to-high impedance time for actively driven POR configs with respect to negation of PORESET_B | — | 5 | SYSClKs | 2 |
| Notes: | | | | |
| 1. PORESET_B must be driven asserted before the core and platform power supplies are powered up. | | | | |
| 2. SYSClK is the primary clock input for the chip. | | | | |
| 3. The device asserts HRESET_B as an output when PORESET_B is asserted to initiate the power-on reset process. The device releases HRESET_B sometime after PORESET_B is deasserted. The exact sequencing of HRESET_B deassertion is documented in the reference manual's "Power-on Reset Sequence" section. | | | | |
| 4. The system/board must be designed to ensure the input requirement to the device is achieved. Proper device operation is guaranteed for inputs meeting this requirement by design, simulation, characterization, or functional testing. | | | | |
| 5. For proper clock selection, terminate cfg_eng_use0 with a pull up or pull down of 4.7 k Ω to ensure that the signal will have a valid state as soon as the IO voltage reach its operating condition. | | | | |

This table provides the phase-locked loop (PLL) lock times.

Table 22. PLL lock times

| Parameter/Condition | Min | Max | Unit | Notes |
|---|-----|-----|---------|-------|
| PLL lock times (Core, platform, DDR only) | — | 100 | μ s | — |

3.9 Battery-backed security monitor interface

This section describes the DC and AC electrical characteristics for the battery-backed security monitor interface, which includes TA_BB_TMP_DETECT_B.

3.9.1 Battery-backed security monitor interface DC electrical characteristics

This table provides the DC electrical characteristics for the battery-backed security monitor interface operating at 1.0 V (TA_BB_V_{DD}).

Table 23. Battery-backed security monitor interface DC electrical characteristics (TA_BB_V_{DD} = 1.0 V)³

| Parameter | Symbol | Min | Max | Unit | Notes |
|--|-----------------|--------------------------------|--------------------------------|------|-------|
| Input high voltage | V _{IH} | 0.7 x TA_BB_V _{DD} | — | V | 1 |
| Input low voltage | V _{IL} | — | 0.3 x TA_BB_V _{DD} | V | 1 |
| Input current (V _{IN} = 0 V or V _{IN} = TA_BB_V _{DD}) | I _{IN} | — | ±50 | μA | 2 |
| 1. The min V _{IL} and max V _{IH} values are based on the respective min and max TA_BB_V _{DD} values found in Table 3 . 2. The symbol V _{IN} , in this case, represents the TA_BB_V _{DD} symbol referenced in Table 3 . 3. For recommended operating conditions, see Table 3 . | | | | | |

This table provides the DC electrical characteristics for the battery-backed security monitor interface operating at 0.9 V (TA_BB_V_{DD}).

Table 24. Battery-backed security monitor interface DC electrical characteristics (TA_BB_V_{DD} = 0.9 V)³

| Parameter | Symbol | Min | Max | Unit | Notes |
|--|-----------------|--------------------------------|--------------------------------|------|-------|
| Input high voltage | V _{IH} | 0.7 x TA_BB_V _{DD} | — | V | 1 |
| Input low voltage | V _{IL} | — | 0.3 x TA_BB_V _{DD} | V | 1 |
| Input current (V _{IN} = 0 V or V _{IN} = TA_BB_V _{DD}) | I _{IN} | — | ±50 | μA | 2 |
| 1. The min V _{IL} and max V _{IH} values are based on the respective min and max TA_BB_V _{DD} values found in Table 3 . 2. The symbol V _{IN} , in this case, represents the TA_BB_V _{DD} symbol referenced in Table 3 . 3. For recommended operating conditions, see Table 3 . | | | | | |

3.9.2 Battery-backed security monitor interface AC timing specifications

This table provides the AC timing specifications for the battery-backed security monitor interface.

Table 25. Battery-backed security monitor interface AC timing specifications²

| Parameter | Symbol | Min | Typ | Max | Unit | Notes |
|--|------------------|-----|-----|-----|------|-------|
| TA_BB_TMP_DETECT_B | t_{TMP} | 100 | | | ns | 1 |
| Notes: | | | | | | |
| 1. TA_BB_TMP_DETECT_B is asynchronous to any clock. | | | | | | |
| 2. For recommended operating conditions, see Table 3 . | | | | | | |

3.10 DDR4 SDRAM controller

This section describes the DC and AC electrical specifications for the DDR4 SDRAM controller interface. Note that the required $GV_{\text{DD}}(\text{typ})$ voltage is 1.2 V when interfacing to DDR4 SDRAM.

3.10.1 DDR4 SDRAM interface DC electrical characteristics

This table provides the recommended operating conditions for the DDR SDRAM controller when interfacing to DDR4 SDRAM.

Table 26. DDR4 SDRAM interface DC electrical characteristics ($GV_{\text{DD}} = 1.2 \text{ V}$)¹

| Parameter | Symbol | Min | Max | Unit | Notes |
|---|-----------------|-------------------------------------|-------------------------------------|---------------|-------|
| Input low | V_{IL} | — | $0.7 \times GV_{\text{DD}} - 0.175$ | V | 3, 6 |
| Input high | V_{IH} | $0.7 \times GV_{\text{DD}} + 0.175$ | — | V | 3, 6 |
| I/O leakage current | I_{OZ} | -165 | 165 | μA | 5 |
| Notes: | | | | | |
| 1. GV_{DD} is expected to be within 60 mV of the DRAM's voltage supply at all times. The DRAM's and memory controller's voltage supply may or may not be from the same source. | | | | | |
| 2. V_{TT} and V_{REFCA} are applied directly to the DRAM device. Both V_{TT} and V_{REFCA} voltages must track $GV_{\text{DD}}/2$. | | | | | |
| 3. Input capacitance load for DQ, DQS, and DQS_B are available in the IBIS models. | | | | | |
| 4. See the IBIS model for the complete output IV curve characteristics. | | | | | |
| 5. Output leakage is measured with all outputs disabled, $0\text{V} \leq V_{\text{OUT}} \leq GV_{\text{DD}}$. Made internal per Mazyar's updates in DDR4 spec v2. | | | | | |

Table 26. DDR4 SDRAM interface DC electrical characteristics ($GV_{DD} = 1.2\text{ V}$)¹

| Parameter | Symbol | Min | Max | Unit | Notes |
|--|--------|-----|-----|------|-------|
| 6. Internal Vref for data bus must be set to $0.7 \times GV_{DD}$. | | | | | |
| 7. For recommended operating conditions, see Table 3 . | | | | | |

3.10.2 DDR4 SDRAM interface AC timing specifications

This section provides the AC timing specifications for the DDR SDRAM controller interface. The DDR controller supports DDR4 memories. Note that the required $GV_{DD}(\text{typ})$ voltage is 1.2 V when interfacing to DDR4 SDRAM.

3.10.2.1 DDR4 SDRAM interface input AC timing specifications

This table provides the input AC timing specifications for the DDR controller when interfacing to DDR4 SDRAM.

Table 27. DDR4 SDRAM interface input AC timing specifications ($GV_{DD} = 1.2\text{ V} \pm 5\%$)₁

| Parameter | Symbol | Min | Max | Unit | Notes |
|--|------------|------------------------------|------------------------------|------|-------|
| AC input low voltage $\leq 2133\text{ MT/s}$ data rate | V_{ILAC} | — | $0.7 \times GV_{DD} - 0.175$ | V | — |
| AC input high voltage $\leq 2133\text{ MT/s}$ data rate | V_{IHAC} | $0.7 \times GV_{DD} + 0.175$ | — | V | — |
| Note: | | | | | |
| 1. For recommended operating conditions, see Table 3 . | | | | | |

This table provides the input AC timing specifications for the DDR controller when interfacing to DDR4 SDRAM.

Table 28. DDR4 SDRAM interface input AC timing specifications ($GV_{DD} = 1.2\text{ V} \pm 5\%$ for DDR4)³

| Parameter | Symbol | Min | Max | Unit | Notes |
|-----------------------------------|--------------|------|-----|------|-------|
| Controller skew for MDQS-MDQ/MECC | t_{CISKEW} | — | — | ps | 1 |
| 2100 MT/s data rate | | -80 | 80 | | |
| 1800 MT/s data rate | | -93 | 93 | | |
| 1600 MT/s data rate | | -112 | 112 | | |
| 1333 MT/s data rate | | -125 | 125 | | |
| Tolerated Skew for MDQS-MDQ/MECC | t_{DISKEW} | — | — | ps | 2 |
| 2100 MT/s data rate | | -154 | 154 | | |
| 1800 MT/s data rate | | -175 | 175 | | |

Table continues on the next page...

Table 28. DDR4 SDRAM interface input AC timing specifications ($G_{V_{DD}} = 1.2 V \pm 5\%$ for DDR4)³ (continued)

| Parameter | Symbol | Min | Max | Unit | Notes |
|---------------------|--------|------|-----|------|-------|
| 1600 MT/s data rate | | -200 | 200 | | |
| 1333 MT/s data rate | | -250 | 250 | | |

Notes:

1. t_{CISKEW} represents the total amount of skew consumed by the controller between MDQS[n] and any corresponding bit that is captured with MDQS[n]. This must be subtracted from the total timing budget.
2. The amount of skew that can be tolerated from MDQS to a corresponding MDQ signal is called t_{DISKEW} . This can be determined by the following equation: $t_{DISKEW} = \pm(T \div 4 - \text{abs}(t_{CISKEW}))$ where T is the clock period and $\text{abs}(t_{CISKEW})$ is the absolute value of t_{CISKEW} .
3. For recommended operating conditions, see [Table 3](#).

This figure shows the DDR4 SDRAM interface input timing diagram.

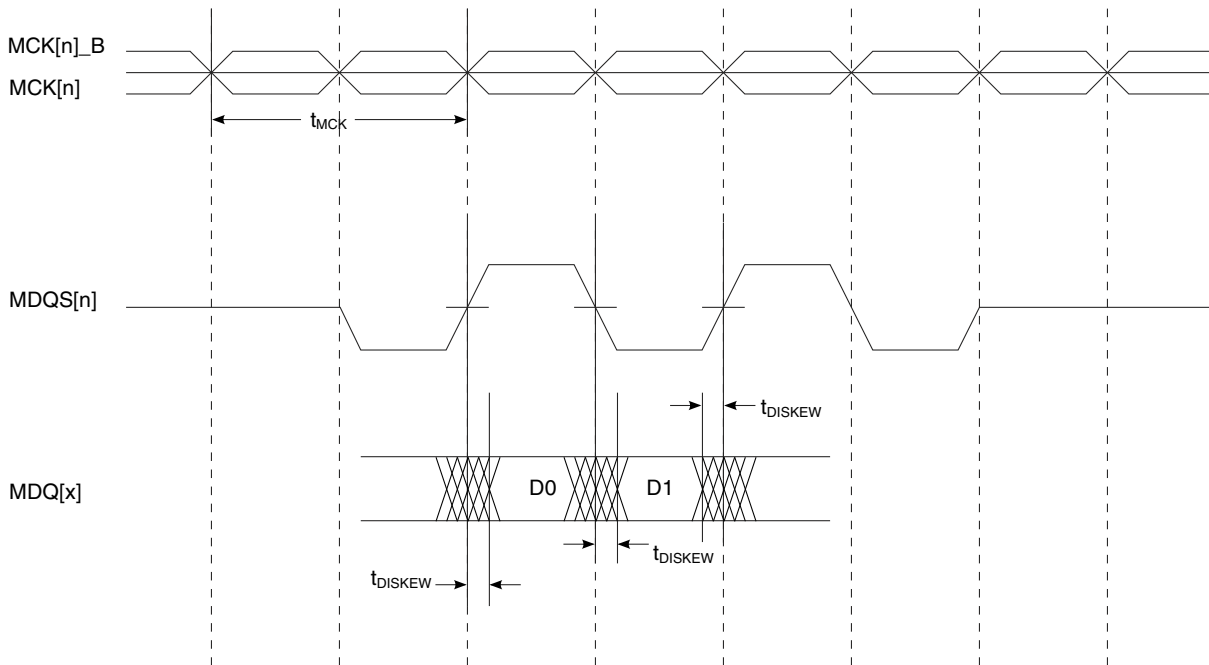

Figure 11. DDR4 SDRAM interface input timing diagram

3.10.2.2 DDR4 SDRAM interface output AC timing specifications

This table contains the output AC timing targets for the DDR4 SDRAM interface.

Table 29. DDR4 SDRAM interface output AC timing specifications ($G_{V_{DD}} = 1.2 V$)⁷

| Parameter | Symbol ¹ | Min | Max | Unit | Notes |
|-------------------|---------------------|-----|------|------|-------|
| MCK[n] cycle time | t_{MCK} | 938 | 1500 | ps | 2 |

Table continues on the next page...

**Table 29. DDR4 SDRAM interface output AC timing specifications ($G_{V_{DD}} = 1.2 V$)⁷
(continued)**

| Parameter | Symbol ¹ | Min | Max | Unit | Notes |
|--|---------------------|----------------------|----------------------|------|-------|
| ADDR/CMD/CNTL output setup with respect to MCK | t_{DDKHAS} | — | — | ps | 3 |
| 2100 MT/s data rate | | 350 | — | | |
| 1800 MT/s data rate | | 410 | — | | |
| 1600 MT/s data rate | | 495 | — | | |
| 1333 MT/s data rate | | 606 | — | | |
| ADDR/CMD/CNTL output hold with respect to MCK | t_{DDKHAX} | — | — | ps | 3 |
| 2100 MT/s data rate | | 350 | — | | |
| 1800 MT/s data rate | | 390 | — | | |
| 1600 MT/s data rate | | 495 | — | | |
| 1333 MT/s data rate | | 606 | — | | |
| MCK to MDQS Skew | t_{DDKMHM} | -150 | 150 | ps | 4,7 |
| MDQ/MECC/MDM output data eye | $t_{DDKXDEYE}$ | — | — | ps | 5 |
| 2100 MT/s data rate | | 320 | — | | |
| 1800 MT/s data rate | | 350 | — | | |
| 1600 MT/s data rate | | 400 | — | | |
| 1333 MT/s data rate | | 500 | — | | |
| MDQS preamble | t_{DDKHMP} | $900 \times t_{MCK}$ | — | ps | — |
| MDQS postamble | t_{DDKHME} | $400 \times t_{MCK}$ | $600 \times t_{MCK}$ | ps | — |

1. The symbols used for timing specifications follow the pattern of $t_{(\text{first two letters of functional block})(\text{signal})(\text{state})(\text{reference})(\text{state})}$ for inputs and $t_{(\text{first two letters of functional block})(\text{reference})(\text{state})(\text{signal})(\text{state})}$ for outputs. Output hold time can be read as DDR timing (DD) from the rising or falling edge of the reference clock (KH or KL) until the output went invalid (AX or DX). For example, t_{DDKHAS} symbolizes DDR timing (DD) for the time t_{MCK} memory clock reference (K) goes from the high (H) state until outputs (A) are setup (S) or output valid time. Also, t_{DDKLDX} symbolizes DDR timing (DD) for the time t_{MCK} memory clock reference (K) goes low (L) until data outputs (D) are invalid (X) or data output hold time.

2. All MCK/MCK_B and MDQS/MDQS_B referenced measurements are made from the crossing of the two signals.

3. ADDR/CMD/CNTL includes all DDR SDRAM output signals except MCK/MCK_B, MCS_B, and MDQ/MECC/MDM/MDQS.

4. Note that t_{DDKMHM} follows the symbol conventions described in note 1. For example, t_{DDKMHM} describes the DDR timing (DD) from the rising edge of the MCK[n] clock (KH) until the MDQS signal is valid (MH). t_{DDKMHM} can be modified through control of the MDQS override bits (called WR_DATA_DELAY) in the TIMING_CFG_2 register. This is typically set to the same delay as in DDR_SDRAM_CLK_CNTL[CLK_ADJUST]. The timing parameters listed in the table assume that these two parameters have been set to the same adjustment value. See the chip reference manual for a description and explanation of the timing modifications enabled by the use of these bits.

5. Available eye for data (MDQ), ECC (MECC), and data mask (MDM) outputs at the pin of the processor. Memory controller will center the strobe (MDQS) in the available data eye at the DRAM (end point) during the initialization.

6. Note that this is required to program the start value of the DQS adjust for write leveling.

7. For recommended operating conditions, see [Table 3](#).

NOTE

For the ADDR/CMD/CNTL setup and hold specifications in [Table 3](#), it is assumed that the clock control register is set to

adjust the memory clocks by ½ applied cycle for data rates of 1866 MT/s or less and 9/16 applied cycle for data rates greater than 1866 MT/s. It is recommended that, during system validation, memory clocks are adjusted to best fit the particular system design.

This figure shows the DDR4 SDRAM interface output timing for the MCK to MDQS skew measurement (t_{DDKHMH}).

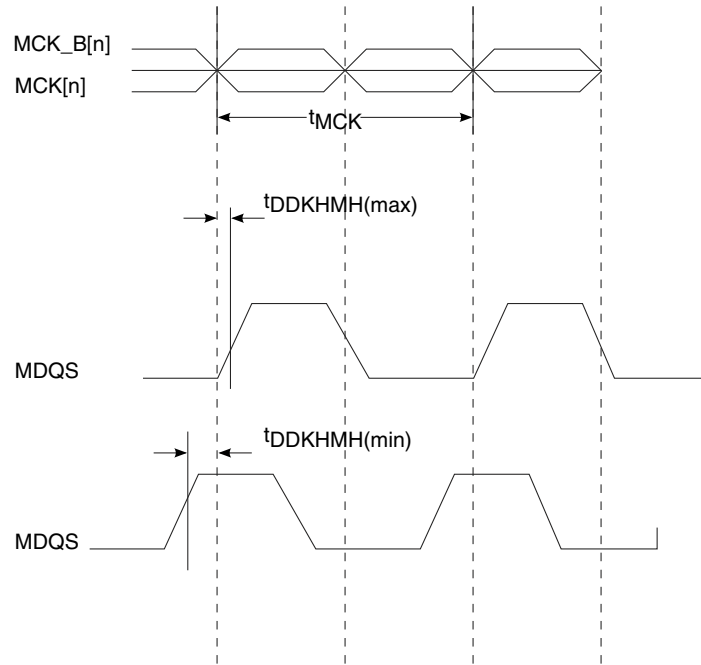

Figure 12. t_{DDKHMH} timing diagram

This figure shows the DDR4 SDRAM output timing diagram.



Figure 13. DDR4 output timing diagram

3.11 Dual universal asynchronous receiver/transmitter (DUART) interface

This section describes the DC and AC electrical characteristics for the DUART interface.

3.11.1 DUART DC electrical characteristics

This table provides the DC electrical characteristics for the DUART interface when operating at $DV_{DD} = 3.3\text{ V}$.

Table 30. DUART DC electrical characteristics ($DV_{DD} = 3.3\text{ V}$)¹

| Parameter | Symbol | Min | Max | Unit | Notes |
|--------------------|----------|----------------------|----------------------|------|-------|
| Input high voltage | V_{IH} | $0.7 \times DV_{DD}$ | - | V | 2 |
| Input low voltage | V_{IL} | - | $0.2 \times DV_{DD}$ | V | 2 |

Table continues on the next page...

Electrical characteristics

Table 30. DUART DC electrical characteristics ($DV_{DD} = 3.3\text{ V}$)¹ (continued)

| Parameter | Symbol | Min | Max | Unit | Notes |
|--|----------|-----|-----|---------------|-------|
| Input current ($V_{IN} = 0\text{V}$ or $V_{IN} = DV_{DD}$) | I_{IN} | -50 | 50 | μA | 3 |
| Output high voltage ($I_{OH} = -2.0\text{ mA}$) | V_{OH} | 2.4 | - | V | - |
| Output low voltage ($I_{OL} = 2.0\text{ mA}$) | V_{OL} | - | 0.4 | V | - |

1. For recommended operating conditions, see [Table 3](#).

2. Note that the min V_{IL} and max V_{IH} values are based on the respective min and max DV_{IN} values found in the Recommended Operating Conditions table.

3. Note that the symbol DV_{IN} represents the input voltage of the supply referenced in the Recommended Operating Conditions table.

This table provides the DC electrical characteristics for the DUART interface when operating at $DV_{DD} = 1.8\text{ V}$.

Table 31. DUART DC electrical characteristics ($DV_{DD} = 1.8\text{ V}$)¹

| Parameter | Symbol | Min | Max | Unit | Notes |
|--|----------|----------------------|----------------------|---------------|-------|
| Input high voltage | V_{IH} | $0.7 \times DV_{DD}$ | - | V | 2 |
| Input low voltage | V_{IL} | - | $0.3 \times DV_{DD}$ | V | 2 |
| Input current ($V_{IN} = 0\text{V}$ or $V_{IN} = DV_{DD}$) | I_{IN} | -50 | 50 | μA | 3 |
| Output high voltage ($I_{OH} = -0.5\text{ mA}$) | V_{OH} | 1.35 | - | V | - |
| Output low voltage ($I_{OL} = 0.5\text{ mA}$) | V_{OL} | - | 0.4 | V | - |

1. For recommended operating conditions, see [Table 3](#).

2. Note that the min V_{IL} and max V_{IH} values are based on the respective min and max DV_{IN} values found in the Recommended Operating Conditions table.

3. Note that the symbol DV_{IN} represents the input voltage of the supply referenced in the Recommended Operating Conditions table.

3.11.2 DUART AC timing specifications

This table provides the AC timing specifications for the DUART interface.

Table 32. DUART AC timing specifications

| Parameter | Symbol | Min | Max | Unit | Notes |
|-------------------|--------|---------------------------------|--------------------------|------|-------|
| Minimum baud rate | baud | $f_{PLAT}/(2 \times 1,048,576)$ | - | baud | 1, 2 |
| Maximum baud rate | baud | - | $f_{PLAT}/(2 \times 16)$ | baud | 1, 3 |

1. f_{PLAT} refers to the internal platform clock.

2. The middle of a start bit is detected as the 8th sampled 0 after the 1-to-0 transition of the start bit. Subsequent bit values are sampled each 16th sample.

3. The actual attainable baud rate is limited by the latency of interrupt processing.

3.12 Enhanced secure digital host controller (eSDHC)

This section describes the DC and AC electrical specifications for the eSDHC interface.

3.12.1 eSDHC DC electrical characteristics

This table provides the DC electrical characteristics for the eSDHC interface.

Table 33. eSDHC interface DC electrical characteristics (E/DV_{DD}=3.3 V)³

| Characteristic | Symbol | Min | Max | Unit | Notes |
|--|-------------------------------------|---------------------------|----------------------------|------|-------|
| Input high voltage | V _{IH} | 0.7 x E/DV _{DD} | - | V | 1 |
| Input low voltage | V _{IL} | - | 0.25 x E/DV _{DD} | V | 1 |
| Output high voltage (I _{OH} = -100 μA at E/DV _{DD} min) | V _{OH} | 0.75 x E/DV _{DD} | - | V | - |
| Output low voltage (I _{OL} = 100 μA at E/DV _{DD} min) | V _{OL} | - | 0.125 x E/DV _{DD} | V | - |
| Output high voltage (I _{OH} = -100 μA) | V _{OH} | E/DV _{DD} - 0.2 | - | V | 2 |
| Output low voltage (I _{OL} = 2 mA) | V _{OL} | - | 0.3 | V | 2 |
| Input/output leakage current | (I _{IN} /I _{OZ}) | -10 | 10 | μA | 2 |
| Notes: | | | | | |
| 1. The min V _{IL} and max V _{IH} values are based on the respective min and max EV _{IN} values found in the Table 3 . | | | | | |
| 2. Open-drain mode is for MMC cards only. | | | | | |
| 3. At recommended operating conditions with E/DV _{DD} = 3.3 V. | | | | | |

Table 34. eSDHC interface DC electrical characteristics (E/D/OV_{DD}=1.8 V)³

| Characteristic | Symbol | Min | Max | Unit | Notes |
|--|-----------------|-----------------------------|----------------------------|------|-------|
| Input high voltage | V _{IH} | 0.7 x E/D/OV _{DD} | - | V | 1 |
| Input low voltage | V _{IL} | - | 0.3 x E/D/OV _{DD} | V | 1 |
| Output high voltage (I _{OH} = -2 mA at E/D/OV _{DD} min) | V _{OH} | E/D/OV _{DD} - 0.45 | - | V | - |
| Output low voltage (I _{OL} = 2 mA at EV _{DD} min) | V _{OL} | - | 0.45 | V | - |
| Output high voltage (I _{OH} = -100 μA) | V _{OH} | E/D/OV _{DD} - 0.2 | - | V | 2 |
| Output low voltage (I _{OL} = 2 mA) | V _{OL} | - | 0.3 | V | 2 |

Table continues on the next page...

Table 34. eSDHC interface DC electrical characteristics (E/D/OV_{DD}=1.8 V)³ (continued)

| Characteristic | Symbol | Min | Max | Unit | Notes |
|--|-------------------------------------|-----|-----|------|-------|
| Input/output leakage current | (I _{IN} /I _{OZ}) | -10 | 10 | μA | 2 |
| Notes: | | | | | |
| 1. The min V _{IL} and max V _{IH} values are based on the respective min and max E/D/OV _{IN} values found in the Table 3 . | | | | | |
| 2. Open-drain mode is for MMC cards only. | | | | | |
| 3. At recommended operating conditions with E/D/OV _{DD} = 1.8 V. | | | | | |

3.12.2 eSDHC AC timing specifications

This section provides the AC timing specifications.

This table provides the eSDHC AC timing specifications as defined in [Figure 14](#), [Figure 15](#), and [Figure 16](#).

Table 35. eSDHC AC timing specifications (full-speed/high-speed mode)⁶

| Parameter | Symbol ¹ | Min | Max | Unit | Notes |
|--|--|------|-------|------|---------|
| SDHC_CLK clock frequency: | f _{SHSCK} | 0 | 25/50 | MHz | 2, 4 |
| <ul style="list-style-type: none"> SD/SDIO (full-speed/high-speed mode) MMC (full-speed/high-speed mode) | | | 20/52 | | |
| SDHC_CLK clock low time (full-speed/high-speed mode) | t _{SHSCKL} | 10/7 | - | ns | 4 |
| SDHC_CLK clock high time (full-speed/high-speed mode) | t _{SHSCKH} | 10/7 | - | ns | 4 |
| SDHC_CLK clock rise and fall times | t _{SHSCKR} / t _{SHSCKF} | - | 3 | ns | 4 |
| Input setup times: SDHC_CMD, SDHC_DATx, SDHC_CD to SDHC_CLK | t _{SHSIVKH} | 2.5 | - | ns | 3, 4, 5 |
| Input hold times: SDHC_CMD, SDHC_DATx, SDHC_CD to SDHC_CLK | t _{SHSIXKH} | 2.5 | - | ns | 4, 5 |
| Output hold time: SDHC_CLK to SDHC_CMD, SDHC_DATx valid | t _{SHSKHOX} | -3 | - | ns | 4, 5 |
| Output delay time: SDHC_CLK to SDHC_CMD, SDHC_DATx valid | t _{SHSKHOV} | - | 3 | ns | 4, 5 |

Notes:

1. The symbols used for timing specifications herein follow the pattern of t_{(first two letters of functional block)(signal)(state) (reference)(state)} for inputs and t_{(first two letters of functional block)(reference)(state)(signal)(state)} for outputs. For example, t_{SHKHGX} symbolizes eSDHC high-speed mode device timing (SH) clock reference (K) going to the high (H) state, with respect to the output (O) reaching the invalid state (X) or output hold time. Note that in general, the clock reference symbol is based on five letters representing the clock of a particular functional. For rise and fall times, the latter convention is used with the appropriate letter: R (rise) or F (fall).

2. In full-speed mode, the clock frequency value can be 0-25MHz for an SD/SDIO card and 0-20MHz for an MMC card. In high-speed mode, the clock frequency value can be 0-50MHz for an SD/SDIO card and 0-52MHz for an MMC card.

Table 35. eSDHC AC timing specifications (full-speed/high-speed mode)⁶

| Parameter | Symbol ¹ | Min | Max | Unit | Notes |
|---|---------------------|-----|-----|------|-------|
| 3. SDHC_SYNC_OUT/IN loop back is recommended to compensate the clock delay. In case the SDHC_SYNC_OUT/IN loopback is not used, to satisfy setup timing, one-way board-routing delay between host and card, on SDHC_CLK, SDHC_CMD, and SDHC_DATx should not exceed 1ns for any high-speed MMC card. For any high-speed or default speed mode SD card, the one-way board-routing delay between host and card, on SDHC_CLK, SDHC_CMD, and SDHC_DATx should not exceed 1.5ns. | | | | | |
| 4. $C_{CARD} \leq 10 \text{ pF}$, (1 card), and $C_L = C_{BUS} + C_{HOST} + C_{CARD} \leq 40 \text{ pF}$. | | | | | |
| 5. The parameter values apply to both full-speed and high-speed modes. | | | | | |
| 6. For recommended operating conditions, see Table 3 . | | | | | |

This figure provides the eSDHC clock input timing diagram.



Figure 14. eSDHC clock input timing diagram

This figure provides the input AC timing diagram for high-speed mode.



Figure 15. eSDHC high-speed mode input AC timing diagram

This figure provides the output AC timing diagram for high-speed mode.

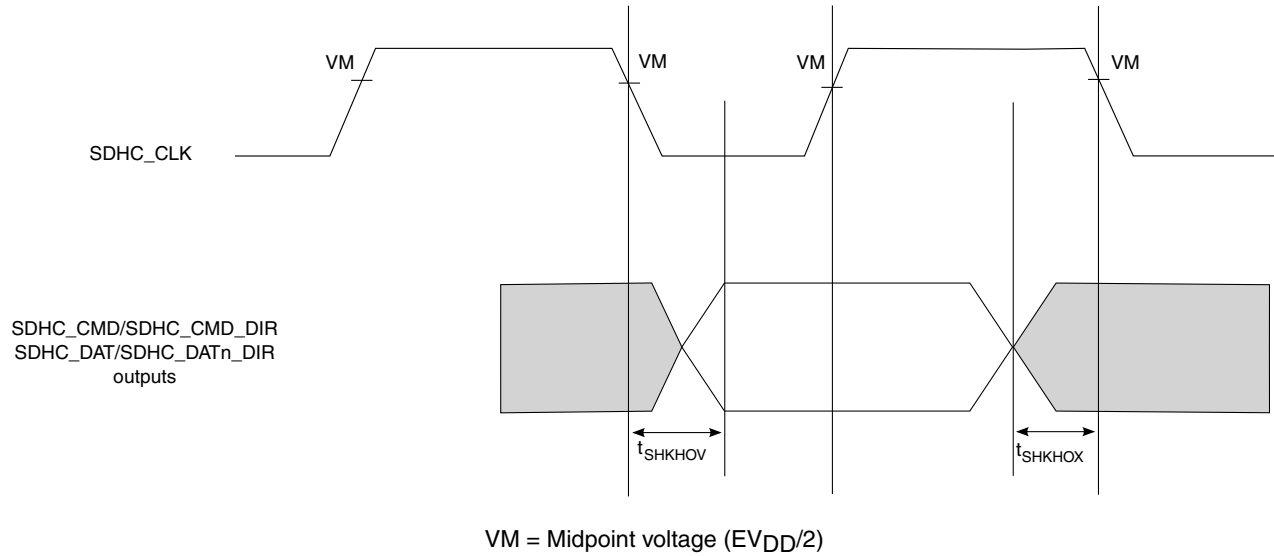

Figure 16. eSDHC high-speed mode output AC timing diagram

This table provides the eSDHC AC timing specifications for SDR50 mode.

Table 36. eSDHC AC timing specifications (SDR50)²

| Parameter | Symbol | Min | Max | Unit | Notes |
|---|-------------------------------|------|-----|------|-------|
| SDHC_CLK clock frequency | f_{SHSCK} | 0 | 100 | MHz | - |
| SDHC_CLK clock rise and fall times | $t_{SHSCKR}/$ t_{SHSCKF} | - | 2 | ns | 1 |
| Skew between SDHC_CLK_SYNC_OUT and SDHC_CLK | t_{SHSCK} | -0.1 | 0.1 | ns | 1 |
| Input setup times: SDHC_CMD, SDHC_DATx to SDHC_CLK_SYNC_IN | $t_{SHSIVKH}$ | 2.1 | - | ns | 1 |
| Input hold times: SDHC_CMD, SDHC_DATx to SDHC_CLK_SYNC_IN | $t_{SHSIXKH}$ | 1.1 | - | ns | 1 |
| Output hold time: SDHC_CLK to SDHC_CMD, SDHC_DATx valid, SDHC_DATx_DIR, SDHC_CMD_DIR | $t_{SHSKHOX}$ | 1.7 | - | ns | 1 |
| Output delay time: SDHC_CLK to SDHC_CMD, SDHC_DATx valid, SDHC_DATx_DIR, SDHC_CMD_DIR | $t_{SHSKHOV}$ | - | 6.1 | ns | 1 |
| Notes: | | | | | |
| 1. $C_{CARD} \leq 10$ pF, (1 card), and $C_L = C_{BUS} + C_{HOST} + C_{CARD} \leq 30$ pF. | | | | | |
| 2. For recommended operating conditions, see Table 3 . | | | | | |

This figure provides the eSDHC clock input timing diagram for SDR50 mode.

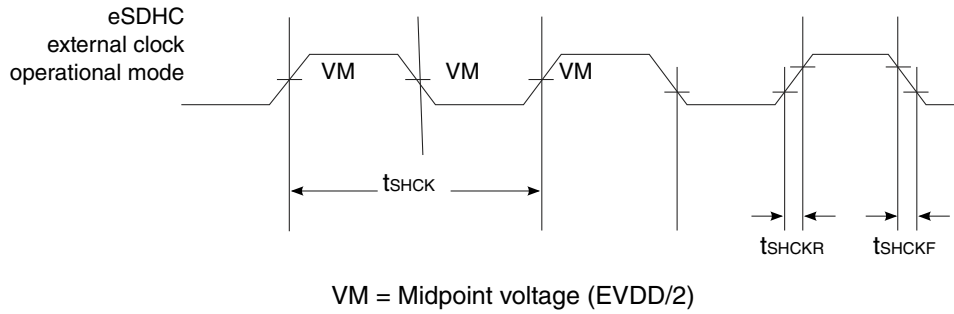

Figure 17. eSDHC SDR50 mode clock input timing diagram

This figure provides the eSDHC input AC timing diagram for SDR50 mode.



Figure 18. eSDHC SDR50 mode input AC timing diagram

This figure provides the eSDHC output timing diagram for SDR50 mode.

Electrical characteristics

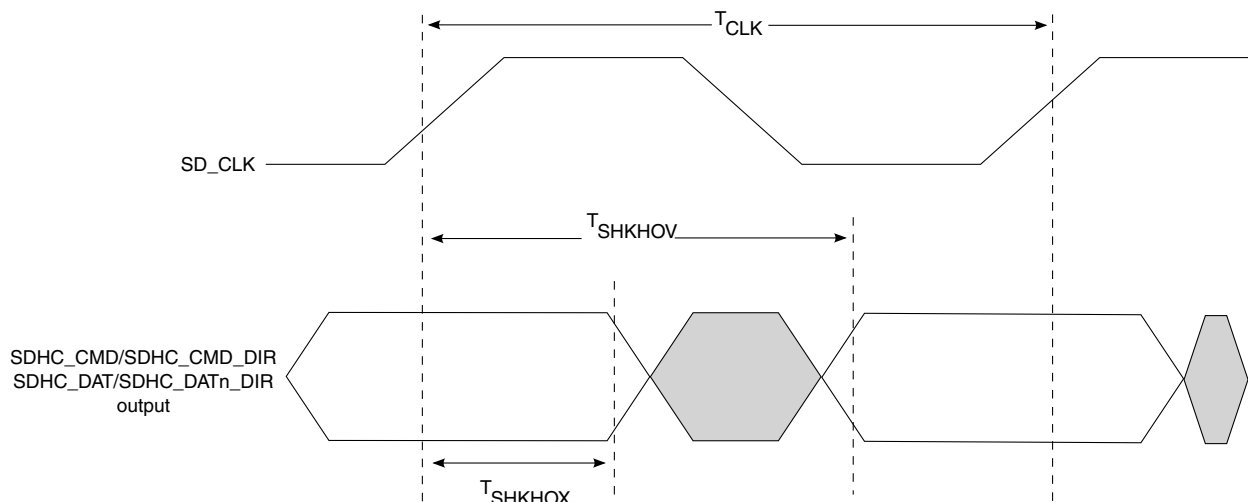

Figure 19. eSDHC SDR50 mode output timing diagram

This table provides the eSDHC AC timing specifications for DDR50/DDR mode.

Table 37. eSDHC AC timing specifications (DDR50/DDR)³

| Parameter | | Symbol | Min | Max | Units | Notes |
|---|--------------------|---------------|------|------|-------|-------|
| SDHC_CLK clock frequency | SD/SDIO DDR50 mode | f_{SHCK} | — | 50 | MHz | — |
| | eMMC DDR mode | | | 52 | | |
| Skew between SDHC_CLK_SYNC_OUT and SDHC_CLK | | t_{SHSCSK} | -0.1 | 0.1 | ns | — |
| SDHC_CLK clock rise and fall times | SD/SDIO DDR50 mode | $t_{SHCKR}/$ | — | 4 | ns | 1, 2 |
| | eMMC DDR mode | t_{SHCKF} | | 2 | | |
| Input setup times: SDHC_DATx to SDHC_CLK_SYNC_IN | SD/SDIO DDR50 mode | $t_{SHDIVKH}$ | 2.0 | — | ns | 1 |
| | eMMC DDR mode | | 1.6 | | | 2 |
| Input hold times: SDHC_DATx to SDHC_CLK_SYNC_IN | SD/SDIO DDR50 mode | $t_{SHDIXKH}$ | 1.3 | — | ns | 1 |
| | eMMC DDR mode | | 1.3 | | | 2, 4 |
| Output hold time: SDHC_CLK to SDHC_DATx valid, SDHC_DATx_DIR | SD/SDIO DDR50 mode | $t_{SHDKHOX}$ | 1.7 | — | ns | 1 |
| | eMMC DDR mode | | 3.4 | | | 2 |
| Output delay time: SDHC_CLK to SDHC_DATx valid, SDHC_DATx_DIR | SD/SDIO DDR50 mode | $t_{SHDKHOV}$ | — | 6.1 | ns | 1 |
| | eMMC DDR mode | | | 6.2 | | 2 |
| Input setup times: SDHC_CMD to SDHC_CLK_SYNC_IN | SD/SDIO DDR50 mode | $t_{SHCIVKH}$ | 5.3 | — | ns | 1 |
| | eMMC DDR mode | | 5 | | | 2 |
| Input hold times: SDHC_CMD to SDHC_CLK_SYNC_IN | SD/SDIO DDR50 mode | $t_{SHCIXKH}$ | 1.2 | — | ns | 1 |
| | eMMC DDR mode | | 1.2 | | | 2, 5 |
| Output hold time: SDHC_CLK to SDHC_CMD valid, SDHC_CMD_DIR | SD/SDIO DDR50 mode | $t_{SHCKHOX}$ | 1.7 | — | ns | 1 |
| | eMMC DDR mode | | 3.9 | | | 2 |
| Output delay time: SDHC_CLK to SDHC_CMD valid, SDHC_CMD_DIR | SD/SDIO DDR50 mode | $t_{SHCKHOV}$ | — | 15.3 | ns | 1 |
| | eMMC DDR mode | | | 15.3 | | 2 |

Table continues on the next page...

Table 37. eSDHC AC timing specifications (DDR50/DDR)³ (continued)

| Parameter | Symbol | Min | Max | Units | Notes |
|---|--------|-----|-----|-------|-------|
| Notes: | | | | | |
| 1. $C_{CARD} \leq 10 \text{ pF}$, (1 card). | | | | | |
| 2. $C_L = C_{BUS} + C_{HOST} + C_{CARD} \leq 20 \text{ pF}$ for MMC, $\leq 25\text{pF}$ for Input Data of DDR50, $\leq 30\text{pF}$ for Input CMD of DDR50. | | | | | |
| 3. For recommended operating conditions, see Table 3 . | | | | | |
| 4. Total clock duty cycle and data and clock skew on the board should be limited to 0.2ns. | | | | | |
| 5. Total clock duty cycle and command and clock skew on the board should be limited to 0.3ns. | | | | | |

This figure provides the eSDHC DDR50/DDR mode input AC timing diagram.



Figure 20. eSDHC DDR50/DDR mode input AC timing diagram

This figure provides the eSDHC DDR50/DDR mode output AC timing diagram.

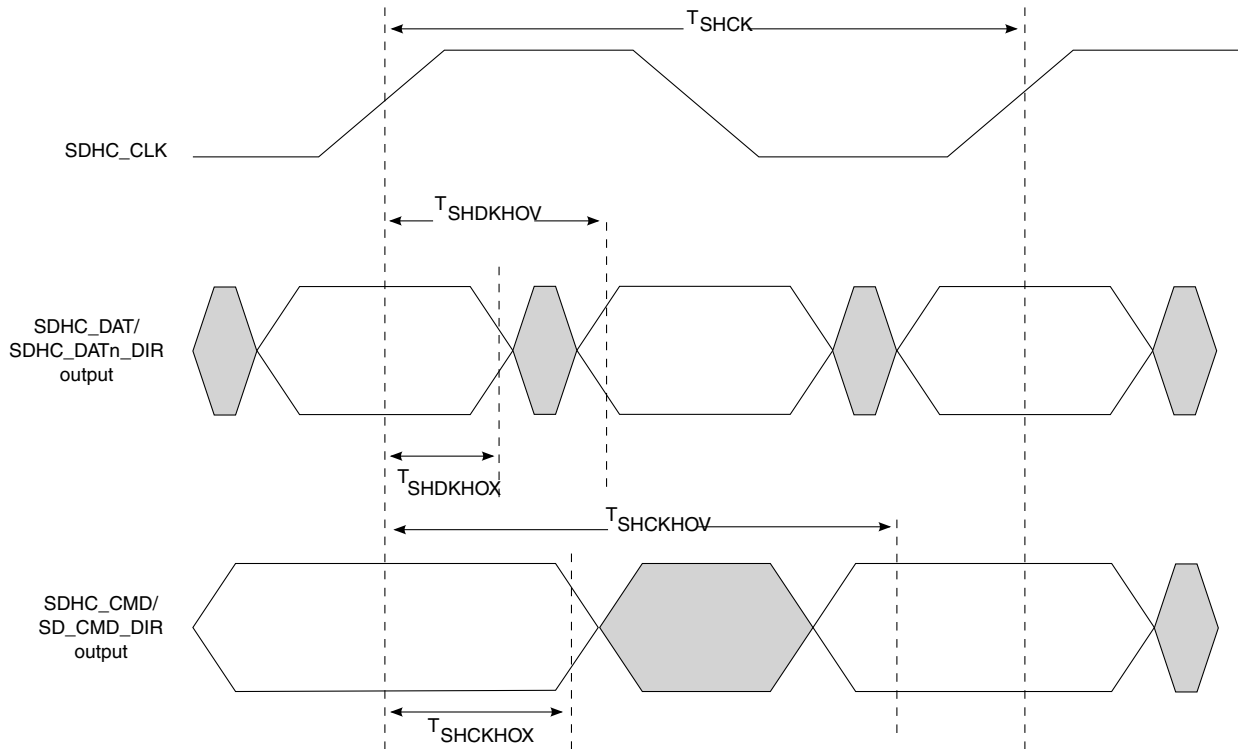

Figure 21. eSDHC DDR50/DDR mode output AC timing diagram

This table provides the eSDHC AC timing specifications for SDR104/eMMC HS200 mode.

Table 38. eSDHC AC timing specifications (SDR104/eMMC HS200)

| Parameter | | Symbol ¹ | Min | Max | Unit | Notes |
|---|---------------------|-----------------------|-------|------|---------------|-------|
| SDHC_CLK clock frequency | SD/SDIO SDR104 mode | f_{SHCK} | - | 167 | MHz | - |
| | eMMC HS200 mode | | | 167 | | - |
| SDHC_CLK clock rise and fall times | | t_{SHCKR}/t_{SHCKF} | - | 1 | ns | 1 |
| Output hold time: SDHC_CLK to SDHC_CMD, SDHC_DATx valid, SDHC_CMD_DIR, SDHC_DATx_DIR | SD/SDIO SDR104 mode | T_{SHKHOX} | 1.58 | - | ns | 1 |
| | eMMC HS200 mode | | 1.6 | | | |
| Output delay time: SDHC_CLK to SDHC_CMD, SDHC_DATx valid, SDHC_CMD_DIR, SDHC_DATx_DIR | SD/SDIO SDR104 mode | T_{SHKHOV} | - | 3.94 | ns | 1 |
| | eMMC HS200 mode | | | 3.92 | | |
| Input data window (UI) | SD/SDIO SDR104 mode | t_{SHIDV} | 0.5 | - | Unit Interval | 1 |
| | eMMC HS200 mode | | 0.475 | | | |
| Notes: | | | | | | |
| 1. $C_L = C_{BUS} + C_{HOST} + C_{CARD} \leq 15\text{pF}$. | | | | | | |
| 2. For recommended operating conditions, see Table 3 . | | | | | | |

This figure provides the eSDHC SDR104/HS200 mode timing diagram.

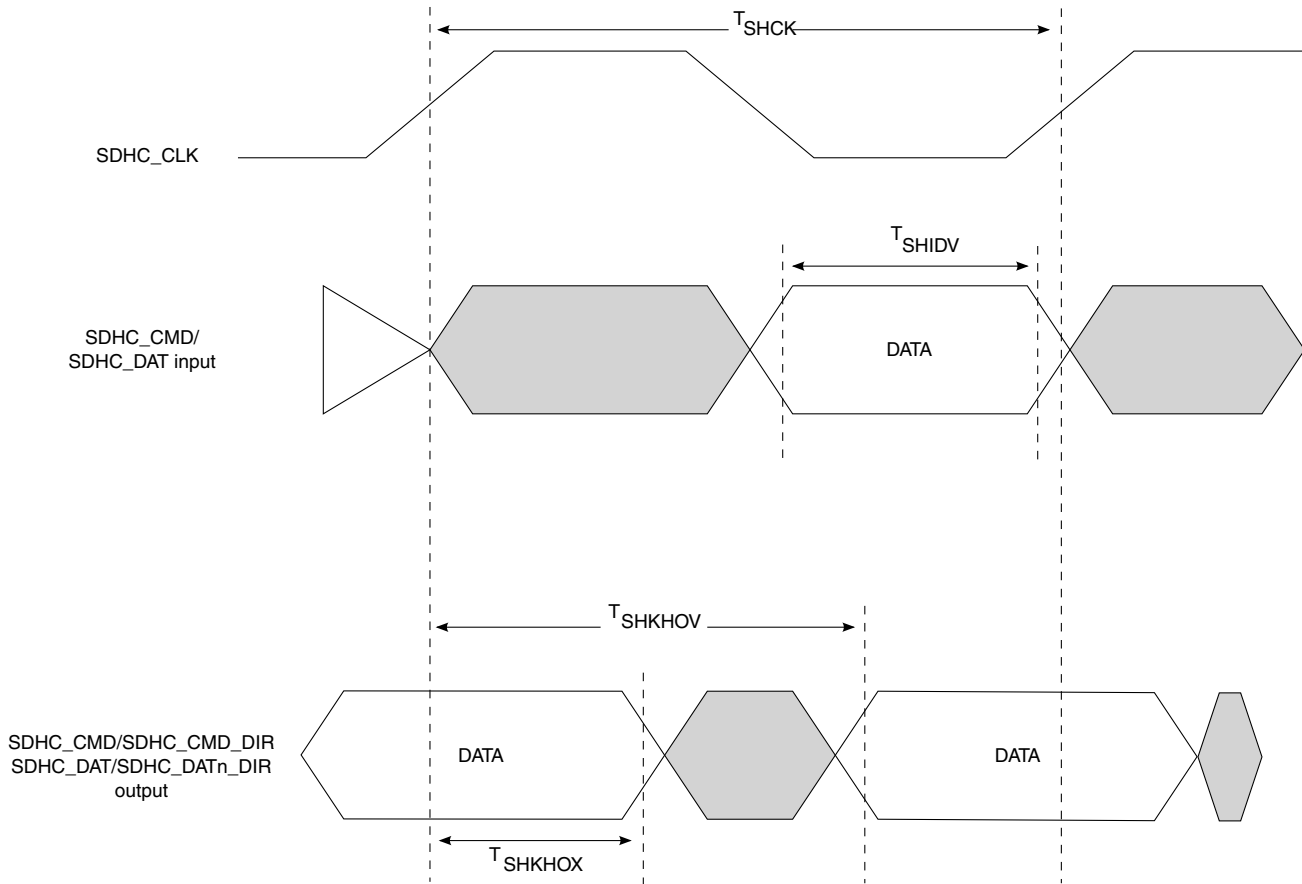

Figure 22. eSDHC SDR104/HS200 mode timing diagram

3.13 Ethernet interface (EMI, RGMII, and IEEE Std 1588™)

This section describes the DC and AC electrical characteristics for the Ethernet controller, Ethernet management, RGMII, and IEEE Std 1588 interfaces.

3.13.1 Ethernet management interface (EMI)

This section describes the electrical characteristics for the Ethernet management interface (EMI).

The EMI1 and EMI2 interface timings are compatible with IEEE Std 802.3™ clauses 22 and 45, respectively.

3.13.1.1 Ethernet management interface 1 (EMI1)

This section describes the electrical characteristics for the EMI1 interface.

The EMI1 interface timing is compatible with IEEE Std 802.3™ clause 22.

3.13.1.1.1 EMI1 DC electrical characteristics

This section describes the DC electrical characteristics for EMI1_MDIO and EMI1_MDC. The pins are available on LV_{DD}. For operating voltages, see the Recommended operating conditions table.

This table provides the EMI1 DC electrical characteristics when operating at LV_{DD} = 2.5 V.

Table 39. EMI1 DC electrical characteristics (LV_{DD} = 2.5 V)¹

| Parameter | Symbol | Min | Max | Unit | Notes |
|--|-----------------|------------------------|------------------------|------|-------|
| Input high voltage | V _{IH} | 0.7 x LV _{DD} | - | V | 2 |
| Input low voltage | V _{IL} | - | 0.2 x LV _{DD} | V | 2 |
| Input current (V _{IN} = 0 or V _{IN} = LV _{DD}) | I _{IN} | -50.0 | 50.0 | μA | 3, 4 |
| Output high voltage (LV _{DD} = min, I _{OH} = -1.0 mA) | V _{OH} | 2.0 | - | V | 4 |
| Output low voltage (LV _{DD} = min, I _{OL} = 1.0 mA) | V _{OL} | - | 0.4 | V | 4 |

1. For recommended operating conditions, see [Table 3](#).
2. The min V_{IL} and max V_{IH} values are based on the respective min and max LV_{IN} values found in [Table 3](#).
3. The symbol LV_{IN} represents the input voltage of the supply referenced in [Table 3](#).
4. The symbol LV_{DD} represents the input voltage of the supply referenced in [Table 3](#).

This table provides the EMI1 DC electrical characteristics when operating at LV_{DD} = 1.8 V.

Table 40. EMI1 DC electrical characteristics (LV_{DD} = 1.8 V)¹

| Parameter | Symbol | Min | Max | Unit | Notes |
|--|-----------------|------------------------|------------------------|------|-------|
| Input high voltage | V _{IH} | 0.7 x LV _{DD} | - | - | 2 |
| Input low voltage | V _{IL} | - | 0.3 x LV _{DD} | - | 2 |
| Input current (V _{IN} = 0 or V _{IN} = LV _{DD}) | I _{IN} | -50.0 | 50.0 | - | 3, 4 |
| Output high voltage (LV _{DD} = min, I _{OH} = -0.5 mA) | V _{OH} | 1.35 | - | - | 4 |
| Output low voltage (LV _{DD} = min, I _{OL} = 0.5 mA) | V _{OL} | - | 0.4 | - | 4 |

1. For recommended operating conditions, see [Table 3](#).
2. The min V_{IL} and max V_{IH} values are based on the respective min and max LV_{IN} values found in [Table 3](#).

Table 40. EMI1 DC electrical characteristics (LV_{DD} = 1.8 V)¹

| Parameter | Symbol | Min | Max | Unit | Notes |
|--|--------|-----|-----|------|-------|
| 3. The symbol LV _{IN} represents the input voltage of the supply referenced in Table 3. | | | | | |
| 4. The symbol LV _{DD} represents the input voltage of the supply referenced in Table 3. | | | | | |

3.13.1.1.2 EMI1 AC timing specifications

This table provides the AC timing specifications for the EMI1 interface.

Table 41. EMI1 AC timing specifications⁴

| Parameter | Symbol | Min | Max | Unit | Notes |
|--|---------------------|----------------------------------|----------------------------------|------|-------|
| MDC frequency | f _{MDC} | - | 2.5 | MHz | 1 |
| MDC clock pulse width high | t _{MDCH} | 160.0 | - | ns | - |
| MDC to MDIO delay | t _{MDKHDX} | (5 x t _{enet_clk}) - 3 | (5 x t _{enet_clk}) + 3 | ns | 2, 3 |
| MDIO to MDC setup time | t _{MDDVKH} | 8.0 | - | ns | - |
| MDIO to MDC hold time | t _{MDDXKH} | 2 | - | ns | - |
| <p>1. This parameter is dependent on the Ethernet clock frequency. The MDIO_CFG [MDIO_CLK_DIV] field determines the clock frequency of the MgmtClk Clock EC_MDC.</p> <p>2. This parameter is dependent on the Ethernet clock frequency. The delay is equal to 5 Ethernet clock periods ± 3 ns. For example, with an Ethernet clock of 400 MHz, the min/max delay is 12.5 ns ± 3 ns.</p> <p>3. t_{enet_clk} is the Ethernet clock period (Frame Manager clock period x 2).</p> <p>4. The symbols used for timing specifications follow these patterns: t_{(first two letters of functional block)(signal)(state)(reference)(state)} for inputs and t_{(first two letters of functional block)(reference)(state)(signal)(state)} for outputs. For example, t_{MDKHDX} symbolizes management data timing (MD) for the time t_{MDC} from clock reference (K) high (H) until data outputs (D) are invalid (X) or data hold time. Also, t_{MDDVKH} symbolizes management data timing (MD) with respect to the time data input signals (D) reach the valid state (V) relative to the t_{MDC} clock reference (K) going to the high (H) state or setup time.</p> | | | | | |

This figure shows the Ethernet management interface 1 timing diagram.

Electrical characteristics



Figure 23. Ethernet management interface 1 timing diagram

3.13.1.2 Ethernet management interface 2 (EMI2)

This section describes the electrical characteristics for the EMI2 interface.

The EMI2 interface timing is compatible with IEEE Std 802.3™ clause 45.

3.13.1.2.1 EMI2 DC electrical characteristics

This section describes the DC electrical characteristics for EMI2_MDIO and EMI2_MDC. The pins are available on TV_{DD} . For operating voltages, see [Table 3](#).

This table provides the EMI2 DC electrical characteristics when operating at $TV_{DD} = 2.5$ V.

Table 42. EMI2 DC electrical characteristics ($TV_{DD} = 2.5$ V)¹

| Parameter | Symbol | Min | Max | Unit | Notes |
|--|----------|----------------------|----------------------|------|-------|
| Input high voltage | V_{IH} | $0.7 \times TV_{DD}$ | - | - | 2 |
| Input low voltage | V_{IL} | - | $0.2 \times TV_{DD}$ | - | 2 |
| Input current ($V_{IN} = 0$ or $V_{IN} = TV_{DD}$) | I_{IN} | -50.0 | 50.0 | - | 3, 4 |
| Output high voltage ($TV_{DD} = \text{min}$, $I_{OH} = -1.0$ mA) | V_{OH} | 2.0 | - | - | 4 |
| Output low voltage ($TV_{DD} = \text{min}$, $I_{OL} = 1.0$ mA) | V_{OL} | - | 0.4 | - | 4 |

1. For recommended operating conditions, see [Table 3](#).

2. The min V_{IL} and max V_{IH} values are based on the respective min and max TV_{IN} values found in [Table 3](#).

Table 42. EMI2 DC electrical characteristics (TV_{DD} = 2.5 V)¹

| Parameter | Symbol | Min | Max | Unit | Notes |
|--|--------|-----|-----|------|-------|
| 3. The symbol TV _{IN} represents the input voltage of the supply referenced in Table 3. | | | | | |
| 4. The symbol TV _{DD} represents the input voltage of the supply referenced in Table 3. | | | | | |

This table provides the EMI2 DC electrical characteristics when operating at TV_{DD} = 1.8 V.

Table 43. EMI2 DC electrical characteristics (TV_{DD} = 1.8 V)¹

| Parameter | Symbol | Min | Max | Unit | Notes |
|---|-----------------|------------|------------|------|-------|
| Input high voltage | V _{IH} | 0.7 x TVDD | - | - | 2 |
| Input low voltage | V _{IL} | - | 0.3 x TVDD | - | 2 |
| Input current (V _{IN} = 0 or V _{IN} = TV _{DD}) | I _{IN} | -50.0 | 50.0 | - | 3, 4 |
| Output high voltage (TV _{DD} = min, I _{OH} = -0.5 mA) | V _{OH} | 1.35 | - | - | 4 |
| Output low voltage (TV _{DD} = min, I _{OL} = 0.5 mA) | V _{OL} | - | 0.4 | - | 4 |
| 1. For recommended operating conditions, see Table 3. | | | | | |
| 2. The min V _{IL} and max V _{IH} values are based on the respective min and max TV _{IN} values found in Table 3. | | | | | |
| 3. The symbol TV _{IN} represents the input voltage of the supply referenced in Table 3. | | | | | |
| 4. The symbol TV _{DD} represents the input voltage of the supply referenced in Table 3. | | | | | |

This table provides the EMI2 DC electrical characteristics when operating at TV_{DD} = 1.2 V.

Table 44. EMI2 DC electrical characteristics (TV_{DD} = 1.2 V)¹

| Parameter | Symbol | Min | Max | Unit | Notes |
|---|-----------------|------------|------------|------|-------|
| Input high voltage | V _{IH} | 0.7 x TVDD | - | - | 2 |
| Input low voltage | V _{IL} | - | 0.2 x TVDD | - | 2 |
| Output low current (V _{OL} = 0.2 V) | I _{OL} | 4.0 | - | mA | - |
| Output high voltage (TV _{DD} = min, I _{OH} = -100 μA) | V _{OH} | 1.0 | - | V | 3 |
| Output low voltage (TV _{DD} = min, I _{OL} = 100 μA) | V _{OL} | - | 0.2 | V | 3 |
| Input capacitance | C _{IN} | - | 10.0 | pF | - |
| 1. For recommended operating conditions, see Table 3. | | | | | |
| 2. The min V _{IL} and max V _{IH} values are based on the respective min and max TV _{IN} values found in Table 3. | | | | | |
| 3. The symbol TV _{DD} represents the input voltage of the supply referenced in Table 3. | | | | | |

3.13.1.2.2 EMI2 AC timing specifications

This table provides the AC timing specifications for the EMI2 interface.

Table 45. EMI2 AC timing specifications⁴

| Parameter | Symbol | Min | Max | Unit | Notes |
|----------------------------|--------------|--------------------------------|--------------------------------|------|-------|
| MDC frequency | f_{MDC} | - | 2.5 | MHz | 1 |
| MDC clock pulse width high | t_{MDCH} | 160.0 | - | ns | - |
| MDC to MDIO delay | t_{MDKHDX} | $(5 \times t_{enet_clk}) - 3$ | $(5 \times t_{enet_clk}) + 3$ | ns | 2, 3 |
| MDIO to MDC setup time | t_{MDDVKH} | 8.0 | - | ns | - |
| MDIO to MDC hold time | t_{MDDXKH} | 2 | - | ns | 5 |

1. This parameter is dependent on the Ethernet clock frequency. The MDIO_CFG [MDIO_CLK_DIV] field determines the clock frequency of the MgmtClk Clock EC_MDC.

2. This parameter is dependent on the Ethernet clock frequency. The delay is equal to 5 Ethernet clock periods \pm 3 ns. For example, with an Ethernet clock of 400 MHz, the min/max delay is 12.5 ns \pm 3 ns.

3. t_{enet_clk} is the Ethernet clock period (Frame Manager clock period x 2).

4. The symbols used for timing specifications follow these patterns: $t_{(first\ two\ letters\ of\ functional\ block)(signal)(state)(reference)(state)}$ for inputs and $t_{(first\ two\ letters\ of\ functional\ block)(reference)(state)(signal)(state)}$ for outputs. For example, t_{MDKHDX} symbolizes management data timing (MD) for the time t_{MDC} from clock reference (K) high (H) until data outputs (D) are invalid (X) or data hold time. Also, t_{MDDVKH} symbolizes management data timing (MD) with respect to the time data input signals (D) reach the valid state (V) relative to the t_{MDC} clock reference (K) going to the high (H) state or setup time.

5. See "AN5144, LS1088A Design Checklist" for more details.

This figure shows the Ethernet management interface 2 timing diagram.



Figure 24. Ethernet management interface 2 timing diagram

3.13.2 IEEE 1588 interface

This section describes the DC and AC electrical characteristics for the IEEE 1588 interface.

3.13.2.1 IEEE 1588 DC electrical characteristics

This table provides the IEEE 1588 DC electrical characteristics when operating at $LV_{DD} = 2.5\text{ V}$ supply.

Table 46. IEEE 1588 DC electrical characteristics ($LV_{DD} = 2.5\text{ V}$)¹

| Parameter | Symbol | Min | Typ | Max | Unit | Notes |
|--|----------|----------------------|-----|----------------------|---------------|-------|
| Input high voltage | V_{IH} | $0.7 \times LV_{DD}$ | - | - | V | 2 |
| Input low voltage | V_{IL} | - | - | $0.2 \times LV_{DD}$ | V | 2 |
| Input current ($V_{IN} = 0$ or $V_{IN} = LV_{DD}$) | I_{IN} | -50.0 | - | 50.0 | μA | 3 |
| Output high voltage ($LV_{DD} = \text{min}$, $I_{OH} = -1.0\text{ mA}$) | V_{OH} | 2.0 | - | - | V | - |
| Output low voltage ($LV_{DD} = \text{min}$, $I_{OL} = 1.0\text{ mA}$) | V_{OL} | - | - | 0.4 | V | - |

1. For recommended operating conditions, see [Table 3](#).
 2. The min V_{IL} and max V_{IH} values are based on the respective min and max LV_{IN} values found in [Table 3](#).
 3. The symbol LV_{IN} represents the input voltage of the supply referenced in [Table 3](#).

This table provides the IEEE 1588 DC electrical characteristics when operating at $LV_{DD} = 1.8\text{ V}$ supply.

Table 47. IEEE 1588 DC electrical characteristics ($LV_{DD} = 1.8\text{ V}$)¹

| Parameter | Symbol | Min | Typ | Max | Unit | Notes |
|--|----------|----------------------|-----|----------------------|---------------|-------|
| Input high voltage | V_{IH} | $0.7 \times LV_{DD}$ | - | - | V | 2 |
| Input low voltage | V_{IL} | - | - | $0.3 \times LV_{DD}$ | V | 2 |
| Input current ($V_{IN} = 0$ or $V_{IN} = LV_{DD}$) | I_{IN} | -50.0 | - | 50.0 | μA | 3 |
| Output high voltage ($LV_{DD} = \text{min}$, $I_{OH} = -0.5\text{ mA}$) | V_{OH} | 1.35 | - | - | V | - |
| Output low voltage ($LV_{DD} = \text{min}$, $I_{OL} = 0.5\text{ mA}$) | V_{OL} | - | - | 0.4 | V | - |

1. For recommended operating conditions, see [Table 3](#).
 2. The min V_{IL} and max V_{IH} values are based on the respective min and max LV_{IN} values found in [Table 3](#).
 3. The symbol LV_{IN} represents the input voltage of the supply referenced in [Table 3](#).

3.13.2.2 IEEE 1588 AC timing specifications

This table provides the AC timing specifications for the IEEE 1588 interface.

Table 48. IEEE 1588 AC timing specifications

| Parameter | Symbol | Min | Typ | Max | Unit | Notes |
|--|-----------------------------------|-------------------------|------|-------|------|-------|
| TSEC_1588_CLK_IN clock period | $t_{1588CLK}$ | 6.0 | - | - | ns | - |
| TSEC_1588_CLK_IN duty cycle | $t_{T1588CLKH}/t_{T1588CLK}$ | 40.0 | 50.0 | 60.0 | % | 1 |
| TSEC_1588_CLK_IN peak-to-peak jitter | $t_{T1588CLKINJ}$ | - | - | 250.0 | ps | - |
| Rise time TSEC_1588_CLK_IN (20% to 80%) | $t_{T1588CLKINR}$ | 1.0 | - | 2.0 | ns | - |
| Fall time TSEC_1588_CLK_IN (80% to 20%) | $t_{T1588CLKINF}$ | 1.0 | - | 2.0 | ns | - |
| TSEC_1588_CLK_OUT clock period | $t_{T1588CLKOUT}$ | $2 \times t_{T1588CLK}$ | - | - | ns | 2 |
| TSEC_1588_CLK_OUT duty cycle | $t_{T1588CLKOTH}/t_{T1588CLKOUT}$ | 30.0 | 50.0 | 70.0 | % | - |
| TSEC_1588_PULSE_OUT1/2, TSEC_1588_ALARM_OUT1/2 | $t_{T1588OV}$ | 0.5 | - | 4.0 | ns | - |
| TSEC_1588_TRIG_IN1/2 pulse width | $t_{T1588TRIGH}$ | $2 \times t_{T1588CLK}$ | - | - | ns | 1, 3 |

1. This needs to be at least two times the clock period of the clock selected by TMR_CTRL[CKSEL]. See the chip reference manual for a description of TMR_CTRL registers.

2. There are three input clock sources for 1588: TSEC_1588_CLK_IN, RTC, and MAC clock / platform clock. When using TSEC_1588_CLK_IN, the minimum clock period is $2 \times t_{T1588CLK}$.

3. The maximum value of $t_{T1588CLK}$ is not only defined by the value of TRX_CLK, but also defined by the recovered clock. For example, for 10/100/1000 Mbps modes, the maximum value of $t_{T1588CLK}$ will be 2800, 280, and 56 ns, respectively.

This figure shows the data and command output AC timing diagram.

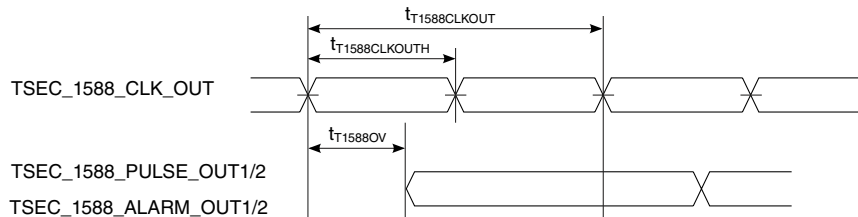

Note: The output delay is counted starting at the rising edge if $t_{T1588CLKOUT}$ is non-inverting. Otherwise, it is counted starting at the falling edge.

Figure 25. IEEE 1588 output AC timing

This figure shows the data and command input AC timing diagram.



Figure 26. IEEE 1588 input AC timing

3.13.3 RGMII interface

This section describes the DC and AC electrical characteristics for the RGMII interface.

3.13.3.1 RGMII DC electrical characteristics

This table provides the DC electrical characteristics for the RGMII interfaces operating at $LV_{DD}/L1V_{DD} = 2.5\text{ V}$.

Table 49. RGMII DC electrical characteristics ($LV_{DD} = 2.5\text{ V}$)¹

| Parameter | Symbol | Min | Max | Unit | Notes |
|--|----------|----------------------|----------------------|---------------|-------|
| Input high voltage | V_{IH} | $0.7 \times LV_{DD}$ | - | V | 2 |
| Input low voltage | V_{IL} | - | $0.2 \times LV_{DD}$ | V | 2 |
| Input current ($V_{IN}=0\text{V}$ or $V_{IN}=LV_{DD}$) | I_{IN} | -50.0 | 50.0 | μA | 3, 4 |
| Output high voltage ($LV_{DD} = \text{min}$, $I_{OH} = -1.0\text{ mA}$) | V_{OH} | 2.0 | - | V | 3 |
| Output low voltage ($LV_{DD} = \text{min}$, $I_{OL} = 1.0\text{ mA}$) | V_{OL} | - | 0.4 | V | 3 |

1. For recommended operating conditions, see Table 3.

2. The min V_{IL} and max V_{IH} values are based on the respective min and max LV_{IN} values found in Table 3.

3. The symbol LV_{DD} represents the input voltage of the supply referenced in Table 3.

4. The symbol LV_{IN} represents the input voltage of the supply referenced in Table 3.

This table provides the DC electrical characteristics for the RGMII interface operating at $LV_{DD} = 1.8\text{ V}$.

Table 50. RGMII DC electrical characteristics ($LV_{DD} = 1.8\text{ V}$)¹

| Parameter | Symbol | Min | Max | Unit | Notes |
|--------------------|----------|----------------------|----------------------|------|-------|
| Input high voltage | V_{IH} | $0.7 \times LV_{DD}$ | - | V | 2 |
| Input low voltage | V_{IL} | - | $0.3 \times LV_{DD}$ | V | 2 |

Table continues on the next page...

Table 50. RGMII DC electrical characteristics (LV_{DD} = 1.8 V)¹ (continued)

| Parameter | Symbol | Min | Max | Unit | Notes |
|---|-----------------|-------|------|------|-------|
| Input current (V _{IN} =0V or V _{IN} =LV _{DD}) | I _{IN} | -50.0 | 50.0 | μA | 3, 4 |
| Output high voltage (LV _{DD} = min, I _{OH} = -0.5 mA) | V _{OH} | 1.35 | - | V | 3 |
| Output low voltage (LV _{DD} = min, I _{OL} = 0.5 mA) | V _{OL} | - | 0.4 | V | 3 |

1. For recommended operating conditions, see [Table 3](#).
 2. The min V_{IL} and max V_{IH} values are based on the respective min and max LV_{IN} values found in [Table 3](#).
 3. The symbol LV_{DD} represents the input voltage of the supply referenced in [Table 3](#).
 4. The symbol LV_{IN} represents the input voltage of the supply referenced in [Table 3](#).

3.13.3.2 RGMII AC timing specifications

This table provides the AC timing specifications for the RGMII interface.

Table 51. RGMII AC timing specifications⁷

| Parameter | Symbol | Min | Typ | Max | Unit | Notes |
|--|--------------------------------------|------|------|------|------|-------|
| Data to clock output skew (at transmitter) | t _{SKRGT_TX} | -400 | 0.0 | 600 | ps | 1 |
| Data to clock input skew (at receiver) | t _{SKRGT_RX} | 1.0 | - | 2.6 | ns | 2 |
| Clock period duration | t _{RGTT} | 7.2 | 8.0 | 8.8 | ns | 3 |
| Duty cycle for 10BASE-T and 100BASE-TX | t _{RGTH} /t _{RGTT} | 40.0 | 50.0 | 60.0 | % | 3, 4 |
| Duty cycle for Gigabit | t _{RGTH} /t _{RGTT} | 45.0 | 50.0 | 55.0 | % | - |
| Rise time (20%-80%) L1/ LV _{DD} =2.5V | t _{RGTR} | - | - | 0.75 | ns | 5, 6 |
| Rise time (20%-80%) L1/ LV _{DD} =1.8V | t _{RGTR} | - | - | 0.54 | ns | 5, 6 |
| Fall time (20%-80%) L1/LV _{DD} =2.5V | t _{RGTF} | - | - | 0.75 | ns | 5, 6 |
| Fall time (20%-80%) L1/LV _{DD} =1.8V | t _{RGTF} | - | - | 0.54 | ns | 5, 6 |

1. The frequency of ECn_RX_CLK (input) should not exceed the frequency of ECn_GTX_CLK (output) by more than 300 ppm.
 2. This implies that PC board design will require clocks to be routed such that an additional trace delay of greater than 1.5 ns is added to the associated clock signal. Many PHY vendors already incorporate the necessary delay inside their device. If so, additional PCB delay is probably not needed.
 3. For 10 and 100 Mbps, t_{RGTT} scales to 400 ns ± 40 ns and 40 ns ± 4 ns, respectively.
 4. Duty cycle may be stretched/shrunk during speed changes or while transitioning to a received packet's clock domains as long as the minimum duty cycle is not violated and stretching occurs for no more than three t_{RGTT} of the lowest speed transitioned between.
 5. Applies to inputs and outputs.
 6. The system/board must be designed to ensure this input requirement to the chip is achieved. Proper device operation is guaranteed for inputs meeting this requirement by design, simulation, characterization, or functional testing.

Table 51. RGMII AC timing specifications⁷

| Parameter | Symbol | Min | Typ | Max | Unit | Notes |
|---|--------|-----|-----|-----|------|-------|
| 7. In general, the clock reference symbol representation is based on the symbol RGT, which represents RGMII timing. Note that the notation for rise (R) and fall (F) times follows the clock symbol that is being represented. For symbols representing skews, the subscript is skew (SK) followed by the clock that is being skewed (RGT). | | | | | | |

This figure shows the RGMII AC timing and multiplexing diagrams.



Figure 27. RGMII AC timing and multiplexing diagrams

NOTE

NXP guarantees timings generated from the MAC. Board designers must ensure delays needed at the PHY or the MAC.

3.14 General purpose input/output (GPIO) interface

This section describes the DC and AC electrical characteristics for the GPIO interface.

3.14.1 GPIO DC electrical characteristics

This table provides the DC electrical characteristics for the GPIO interface operating at $D/EV_{DD} = 3.3\text{ V}$.

Table 52. GPIO DC electrical characteristics ($D/EV_{DD} = 3.3\text{ V}$)¹

| Parameter | Symbol | Min | Max | Unit | Notes |
|--|----------|------------------------|------------------------|---------|-------|
| Input high voltage | V_{IH} | $0.7 \times D/EV_{DD}$ | - | V | 2 |
| Input low voltage | V_{IL} | - | $0.2 \times D/EV_{DD}$ | V | 2 |
| Input current ($V_{IN} = 0V$ or $V_{IN} = LV_{DD}$) | I_{IN} | - | ± 50 | μA | 3 |
| Output high voltage ($D/EV_{DD} = \text{min}$, $I_{OH} = -2\text{ mA}$) | V_{OH} | 2.4 | - | V | - |
| Output low voltage ($D/EV_{DD} = \text{min}$, $I_{OL} = 2\text{ mA}$) | V_{OL} | - | 0.4 | V | - |

1. For recommended operating conditions, see [Table 3](#).
 2. The min V_{IL} and max V_{IH} values are based on the respective min and max DV_{IN}/EV_{IN} values found in [Table 3](#).
 3. The symbol DV_{IN}/EV_{IN} represents the input voltage of the supply referenced in [Table 3](#).

This table provides the DC electrical characteristics for the GPIO interface operating at $TV_{DD} = 2.5\text{ V}$.

Table 53. GPIO DC electrical characteristics ($TV_{DD} = 2.5\text{ V}$)¹

| Parameter | Symbol | Min | Max | Unit | Notes |
|--|----------|----------------------|----------------------|---------|-------|
| Input high voltage | V_{IH} | $0.7 \times TV_{DD}$ | - | V | 2 |
| Input low voltage | V_{IL} | - | $0.2 \times TV_{DD}$ | V | 2 |
| Input current ($V_{IN} = 0V$ or $V_{IN} = LV_{DD}$) | I_{IN} | - | ± 50 | μA | 3 |
| Output high voltage ($TV_{DD} = \text{min}$, $I_{OH} = -1\text{ mA}$) | V_{OH} | 2.0 | - | V | - |
| Output low voltage ($TV_{DD} = \text{min}$, $I_{OL} = 1\text{ mA}$) | V_{OL} | - | 0.4 | V | - |

1. For recommended operating conditions, see [Table 3](#).
 2. The min V_{IL} and max V_{IH} values are based on the respective min and max TV_{IN} values found in [Table 3](#).
 3. The symbol TV_{IN} represents the input voltage of the supply referenced in [Table 3](#).

This table provides the DC electrical characteristics for the GPIO interface operating at $D/E/TV_{DD} = 1.8\text{ V}$.

Table 54. GPIO DC electrical characteristics ($D/E/TV_{DD} = 1.8\text{ V}$)¹

| Parameter | Symbol | Min | Max | Unit | Notes |
|--------------------|----------|--------------------------|-----|------|-------|
| Input high voltage | V_{IH} | $0.7 \times D/E/TV_{DD}$ | - | V | 2 |

Table continues on the next page...

Table 54. GPIO DC electrical characteristics (D/E/TV_{DD} = 1.8 V)¹ (continued)

| Parameter | Symbol | Min | Max | Unit | Notes |
|---|-----------------|------|----------------------------|------|-------|
| Input low voltage | V _{IL} | - | 0.3 x D/E/TV _{DD} | V | 2 |
| Input current (V _{IN} = 0V or V _{IN} = LV _{DD}) | I _{IN} | - | ±50 | µA | 3 |
| Output high voltage (D/E/TV _{DD} = min, I _{OH} = -0.5 mA) | V _{OH} | 1.35 | - | V | - |
| Output low voltage (D/E/TV _{DD} = min, I _{OL} = 0.5 mA) | V _{OL} | - | 0.4 | V | - |

1. For recommended operating conditions, see [Table 3](#).

2. The min V_{IL} and max V_{IH} values are based on the respective min and max DV_{IN}/EV_{IN}/TV_{IN} values found in [Table 3](#).

3. The symbol DV_{IN}/EV_{IN}/TV_{IN} represents the input voltage of the supply referenced in [Table 3](#).

This table provides the DC electrical characteristics for the GPIO interface operating at LV_{DD} = 2.5 V.

Table 55. GPIO DC electrical characteristics (LV_{DD} = 2.5 V)¹

| Parameter | Symbol | Min | Max | Unit | Notes |
|---|-----------------|------------|------------|------|-------|
| Input high voltage | V _{IH} | 0.7 x LVDD | - | V | 2 |
| Input low voltage | V _{IL} | - | 0.2 x LVDD | V | 2 |
| Input current (V _{IN} = 0V or V _{IN} = LV _{DD}) | I _{IN} | - | ±50 | µA | 3 |
| Output high voltage (LV _{DD} = min, I _{OH} = -1 mA) | V _{OH} | 2.0 | - | V | - |
| Output low voltage (LV _{DD} = min, I _{OL} = 1 mA) | V _{OL} | - | 0.4 | V | - |

1. For recommended operating conditions, see [Table 3](#).

2. The min V_{IL} and max V_{IH} values are based on the respective min and max LV_{IN} values found in [Table 3](#).

3. The symbol LV_{IN} represents the input voltage of the supply referenced in [Table 3](#).

This table provides the DC electrical characteristics for the GPIO interface operating at O/LV_{DD} = 1.8 V.

Table 56. GPIO DC electrical characteristics (O/LV_{DD} = 1.8 V)¹

| Parameter | Symbol | Min | Max | Unit | Notes |
|---|-----------------|--------------|--------------|------|-------|
| Input high voltage | V _{IH} | 0.7 x O/LVDD | - | V | 2 |
| Input low voltage | V _{IL} | - | 0.3 x O/LVDD | V | 2 |
| Input current (V _{IN} = 0V or V _{IN} = O/LV _{DD}) | I _{IN} | - | ±50 | µA | 3 |
| Output high voltage (O/LV _{DD} = min, I _{OH} = -0.5 mA) | V _{OH} | 1.35 | - | V | - |
| Output low voltage (O/LV _{DD} = min, I _{OL} = 0.5 mA) | V _{OL} | - | 0.4 | V | - |

1. For recommended operating conditions, see [Table 3](#).

Electrical characteristics

Table 56. GPIO DC electrical characteristics (O/LV_{DD} = 1.8 V)¹

| Parameter | Symbol | Min | Max | Unit | Notes |
|---|--------|-----|-----|------|-------|
| 2. The min V _{IL} and max V _{IH} values are based on the respective min and max OV _{IN} /LV _{IN} values found in Table 3. | | | | | |
| 3. The symbol OV _{IN} /LV _{IN} represents the input voltage of the supply referenced in Table 3. | | | | | |

This table provides the DC electrical characteristics for the GPIO interface operating at O/LV_{DD} = 1.8 V.

Table 57. GPIO DC electrical characteristics (TV_{DD} = 1.2 V)¹

| Parameter | Symbol | Min | Max | Unit | Notes |
|---|-----------------|------------------------|------------------------|------|-------|
| Input high voltage | V _{IH} | 0.7 x TV _{DD} | - | - | 2 |
| Input low voltage | V _{IL} | - | 0.2 x TV _{DD} | - | 2 |
| Output low current (V _{OL} = 0.2 V) | I _{OL} | 4.0 | - | mA | - |
| Output high voltage (TV _{DD} = min, I _{OH} = -100 μA) | V _{OH} | 1.0 | - | V | 3 |
| Output low voltage (TV _{DD} = min, I _{OL} = 100 μA) | V _{OL} | - | 0.2 | V | 3 |
| Input capacitance | C _{IN} | - | 10.0 | pF | - |
| 1. For recommended operating conditions, see Table 3. | | | | | |
| 2. The min V _{IL} and max V _{IH} values are based on the respective min and max TV _{IN} values found in Table 3. | | | | | |
| 3. The symbol TV _{DD} represents the input voltage of the supply referenced in Table 3. | | | | | |

3.14.2 GPIO AC timing specifications

This table provides the AC timing specifications for the GPIO interface.

Table 58. GPIO AC timing specifications

| Parameter | Symbol | Min | Unit | Notes |
|---------------------------------|--------------------|------|------|--|
| GPIO inputs-minimum pulse width | t _{PIWID} | 20.0 | ns | GPIO inputs and outputs are asynchronous to any visible clock. GPIO outputs must be synchronized before use by any external synchronous logic. GPIO inputs are required to be valid for at least t _{PIWID} ns to ensure proper operation. |

This figure shows the AC test load for the GPIO interface.

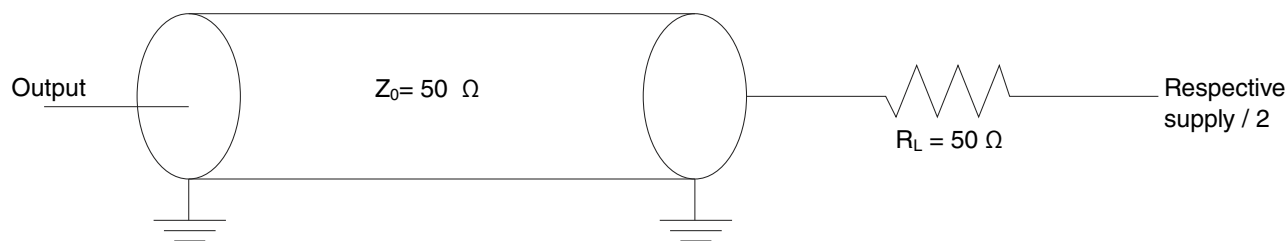

Figure 28. GPIO AC test load

3.15 Generic interrupt controller (GIC) interface

This section describes the DC and AC electrical characteristics for the GIC interface.

3.15.1 GIC DC electrical characteristics

This table provides the DC electrical characteristics for the GIC interface operating at $DV_{DD} = 3.3\text{ V}$.

Table 59. GIC DC electrical characteristics ($DV_{DD} = 3.3\text{ V}$)¹

| Parameter | Symbol | Min | Max | Unit | Notes |
|--|----------|----------------------|----------------------|---------------|-------|
| Input high voltage | V_{IH} | $0.7 \times DV_{DD}$ | - | V | 2 |
| Input low voltage | V_{IL} | - | $0.2 \times DV_{DD}$ | V | 2 |
| Input current ($V_{IN} = 0V$ or $V_{IN} = DV_{DD}$) | I_{IN} | - | ± 50 | μA | 3 |
| Output high voltage ($DV_{DD} = \text{min}$, $I_{OH} = -2\text{ mA}$) | V_{OH} | 2.4 | - | V | - |
| Output low voltage ($DV_{DD} = \text{min}$, $I_{OL} = 2\text{ mA}$) | V_{OL} | - | 0.4 | V | - |

1. For recommended operating conditions, see [Table 3](#).

2. The min V_{IL} and max V_{IH} values are based on the respective min and max DV_{IN} values found in [Table 3](#).

3. The symbol DV_{IN} represents the input voltage of the supply referenced in [Table 3](#).

This table provides the DC electrical characteristics for the GIC interface operating at $DV_{DD} = 1.8\text{ V}$.

Table 60. GIC DC electrical characteristics ($DV_{DD} = 1.8\text{ V}$)¹

| Parameter | Symbol | Min | Max | Unit | Notes |
|--------------------|----------|----------------------|----------------------|------|-------|
| Input high voltage | V_{IH} | $0.7 \times DV_{DD}$ | - | V | 2 |
| Input low voltage | V_{IL} | - | $0.3 \times DV_{DD}$ | V | 2 |

Table continues on the next page...

Electrical characteristics

Table 60. GIC DC electrical characteristics ($DV_{DD} = 1.8\text{ V}$)¹ (continued)

| Parameter | Symbol | Min | Max | Unit | Notes |
|--|----------|------|----------|---------------|-------|
| Input current ($V_{IN} = 0\text{V}$ or $V_{IN} = DV_{DD}$) | I_{IN} | - | ± 50 | μA | 3 |
| Output high voltage ($DV_{DD} = \text{min}$, $I_{OH} = -0.5\text{ mA}$) | V_{OH} | 1.35 | - | V | - |
| Output low voltage ($DV_{DD} = \text{min}$, $I_{OL} = 0.5\text{ mA}$) | V_{OL} | - | 0.4 | V | - |

1. For recommended operating conditions, see [Table 3](#).
 2. The min V_{IL} and max V_{IH} values are based on the respective min and max DV_{IN} values found in [Table 3](#).
 3. The symbol DV_{IN} represents the input voltage of the supply referenced in [Table 3](#).

This table provides the DC electrical characteristics for the GIC interface operating at $LV_{DD} = 2.5\text{ V}$.

Table 61. GIC DC electrical characteristics ($LV_{DD} = 2.5\text{ V}$)¹

| Parameter | Symbol | Min | Max | Unit | Notes |
|--|----------|----------------------|----------------------|---------------|-------|
| Input high voltage | V_{IH} | $0.7 \times LV_{DD}$ | - | V | 2 |
| Input low voltage | V_{IL} | - | $0.2 \times LV_{DD}$ | V | 2 |
| Input current ($V_{IN} = 0\text{V}$ or $V_{IN} = LV_{DD}$) | I_{IN} | - | ± 50 | μA | 3 |
| Output high voltage ($LV_{DD} = \text{min}$, $I_{OH} = -1\text{ mA}$) | V_{OH} | 2.0 | - | V | - |
| Output low voltage ($LV_{DD} = \text{min}$, $I_{OL} = 1\text{ mA}$) | V_{OL} | - | 0.4 | V | - |

1. For recommended operating conditions, see [Table 3](#).
 2. The min V_{IL} and max V_{IH} values are based on the respective min and max LV_{IN} values found in [Table 3](#).
 3. The symbol LV_{IN} represents the input voltage of the supply referenced in [Table 3](#).

This table provides the DC electrical characteristics for the GIC interface operating at $O/LV_{DD} = 1.8\text{ V}$.

Table 62. GIC DC electrical characteristics ($O/LV_{DD} = 1.8\text{ V}$)¹

| Parameter | Symbol | Min | Max | Unit | Notes |
|--|----------|------------------------|------------------------|---------------|-------|
| Input high voltage | V_{IH} | $0.7 \times O/LV_{DD}$ | - | V | 2 |
| Input low voltage | V_{IL} | - | $0.3 \times O/LV_{DD}$ | V | 2 |
| Input current ($V_{IN} = 0\text{V}$ or $V_{IN} = O/LV_{DD}$) | I_{IN} | - | ± 50 | μA | 3 |
| Output high voltage ($O/LV_{DD} = \text{min}$, $I_{OH} = -0.5\text{ mA}$) | V_{OH} | 1.35 | - | V | - |
| Output low voltage ($O/LV_{DD} = \text{min}$, $I_{OL} = 0.5\text{ mA}$) | V_{OL} | - | 0.4 | V | - |

1. For recommended operating conditions, see [Table 3](#).
 2. The min V_{IL} and max V_{IH} values are based on the respective min and max O/LV_{IN} values found in [Table 3](#).
 3. The symbol O/LV_{IN} represents the input voltage of the supply referenced in [Table 3](#).

3.15.2 GIC AC timing specifications

This table provides the AC timing specifications for the GIC interface.

Table 63. GIC AC timing specifications

| Parameter | Symbol | Min | Unit | Notes |
|---|-------------|-----|---------|-------|
| GIC inputs-minimum pulse width | t_{PIWID} | 3.0 | SYSCLKs | 1, 2 |
| 1. Entry and exit from deep sleep respectively require a minimum pulse width t_{PIWID} of 25 SYSCLK. See the applicable device reference manual for details on entry and exit from deep sleep. 2. GIC inputs and outputs are asynchronous to any visible clock. GIC outputs must be synchronized before use by any external synchronous logic. GIC inputs are required to be valid for at least t_{PIWID} ns to ensure proper operation when working in edge triggered mode. | | | | |

3.16 High-speed serial interfaces (HSSI)

The chip features a Serializer/Deserializer (SerDes) interface to be used for high-speed serial interconnect applications. The SerDes interface can be used for PCI Express, SGMII, and serial ATA (SATA) data transfers.

This section describes the most common portion of the SerDes DC electrical specifications: the DC requirement for SerDes reference clocks. The SerDes data lane's transmitter (Tx) and receiver (Rx) reference circuits are also described.

3.16.1 Signal terms definitions

The SerDes utilizes differential signaling to transfer data across the serial link. This section defines the terms that are used in the description and specification of differential signals.

This figure shows how the signals are defined. For illustration purposes only, one SerDes lane is used in the description. This figure shows the waveform for either a transmitter output (SD_TX n _P and SD_TX n _N) or a receiver input (SD_RX n _P and SD_RX n _N). Each signal swings between A volts and B volts where $A > B$.



Figure 29. Differential voltage definitions for transmitter or receiver

Using this waveform, the definitions are as described in the following list. To simplify the illustration, the definitions assume that the SerDes transmitter and receiver operate in a fully symmetrical differential signaling environment:

Single-Ended Swing

The transmitter output signals and the receiver input signals SD_TXn_P, SD_TXn_N, SD_RXn_P and SD_RXn_N each have a peak-to-peak swing of A - B volts. This is also referred to as each signal wire's single-ended swing.

Differential Output Voltage, V_{OD} (or Differential Output Swing)

The differential output voltage (or swing) of the transmitter, V_{OD}, is defined as the difference of the two complementary output voltages: V_{SD_TXn_P} - V_{SD_TXn_N}. The V_{OD} value can be either positive or negative.

Differential Input Voltage, V_{ID} (or Differential Input Swing)

The differential input voltage (or swing) of the receiver, V_{ID}, is defined as the difference of the two complementary input voltages: V_{SD_RXn_P} - V_{SD_RXn_N}. The V_{ID} value can be either positive or negative.

Differential Peak Voltage, V_{DIFFp}

The peak value of the differential transmitter output signal or the differential receiver input signal is defined as the differential peak voltage, V_{DIFFp} = |A - B| volts.

Differential Peak-to-Peak, V_{DIFFp-p}

Because the differential output signal of the transmitter and the differential input signal of the receiver each range from A - B to -(A - B) volts, the peak-to-peak value of the differential transmitter output signal or the differential receiver input signal is defined as differential peak-to-peak voltage, V_{DIFFp-p} = 2 x V_{DIFFp} = 2 x |A - B| volts, which is twice the differential swing in amplitude, or twice the differential peak. For example, the output differential peak-to-peak voltage can also be calculated as V_{TX-DIFFp-p} = 2 x |V_{OD}|.

Differential Waveform

The differential waveform is constructed by subtracting the inverting signal (SD_TXn_N, for example) from the non-inverting signal (SD_TXn_P, for example)

within a differential pair. There is only one signal trace curve in a differential waveform. The voltage represented in the differential waveform is not referenced to ground. See [Figure 34](#) as an example for differential waveform.

Common Mode Voltage, V_{cm}

The common mode voltage is equal to half of the sum of the voltages between each conductor of a balanced interchange circuit and ground. In this example, for SerDes output, $V_{cm_out} = (V_{SD_TXn_P} + V_{SD_TXn_N}) \div 2 = (A + B) \div 2$, which is the arithmetic mean of the two complementary output voltages within a differential pair. In a system, the common mode voltage may often differ from one component's output to the other's input. It may be different between the receiver input and driver output circuits within the same component. It is also referred to as the DC offset on some occasions.

To illustrate these definitions using real values, consider the example of a current mode logic (CML) transmitter that has a common mode voltage of 2.25 V and outputs, TD and TD_B. If these outputs have a swing from 2.0 V to 2.5 V, the peak-to-peak voltage swing of each signal (TD or TD_B) is 500 mV p-p, which is referred to as the single-ended swing for each signal. Because the differential signaling environment is fully symmetrical in this example, the transmitter output's differential swing (V_{OD}) has the same amplitude as each signal's single-ended swing. The differential output signal ranges between 500 mV and -500 mV. In other words, V_{OD} is 500 mV in one phase and -500 mV in the other phase. The peak differential voltage (V_{DIFFp}) is 500 mV. The peak-to-peak differential voltage ($V_{DIFFp-p}$) is 1000 mV p-p.

3.16.2 SerDes reference clocks

The SerDes reference clock inputs are applied to an internal phase-locked loop (PLL) whose output creates the clock used by the corresponding SerDes lanes. The SerDes reference clocks inputs are $SDn_REF_CLK[1:2]_P$ and $SDn_REF_CLK[1:2]_N$.

SerDes may be used for various combinations of the following IP block based on the RCW Configuration field $SRDS_PRTCLn$:

- SGMII (1.25 Gbaud or 3.125 Gbaud), QSGMII (5 Gbps)
- XFI (10.3125 Gb/s)
- PCIe (2.5, 5, and 8 GT/s)
- SATA (1.5, 3.0, and 6.0 Gbps)

The following sections describe the SerDes reference clock requirements and provide application information.

3.16.2.1 SerDes spread-spectrum clock source recommendations

SD n _REF_CLK n _P and SD n _REF_CLK n _N are designed to work with spread-spectrum clocking for the PCI Express protocol only with the spreading specification defined in [Table 64](#). When using spread-spectrum clocking for PCI Express, both ends of the link partners should use the same reference clock. For best results, a source without significant unintended modulation must be used.

The SerDes transmitter does not support spread-spectrum clocking for the SATA protocol. The SerDes receiver does support spread-spectrum clocking on receive, which means the SerDes receiver can receive data correctly from a SATA serial link partner using spread-spectrum clocking.

Spread-spectrum clocking cannot be used if the same SerDes reference clock is shared with other non-spread-spectrum-supported protocols. For example, if spread-spectrum clocking is desired on a SerDes reference clock for the PCI Express protocol and the same reference clock is used for any other protocol, such as SATA or SGMII because of the SerDes lane usage mapping option, spread-spectrum clocking cannot be used at all.

This table provides the source recommendations for SerDes spread-spectrum clocking.

Table 64. SerDes spread-spectrum clock source recommendations ¹

| Parameter | Min | Max | Unit | Notes |
|---|-----|------|------|-------|
| Frequency modulation | 30 | 33 | kHz | — |
| Frequency spread | +0 | -0.5 | % | 2 |
| Notes: | | | | |
| 1. At recommended operating conditions. See Table 3 . | | | | |
| 2. Only down-spreading is allowed. | | | | |

3.16.2.2 SerDes reference clock receiver characteristics

This figure shows a receiver reference diagram of the SerDes reference clocks.



Figure 30. Receiver of SerDes reference clocks

The characteristics of the clock signals are as follows:

- The SerDes transceiver's core power supply voltage requirements (SV_{DD}) are as specified in [Table 3](#).
- The SerDes reference clock receiver reference circuit structure is as follows:
 - The $SDn_REF_CLKn_P$ and $SDn_REF_CLKn_N$ are internally AC-coupled differential inputs as shown in [Figure 30](#). Each differential clock input ($SDn_REF_CLKn_P$ or $SDn_REF_CLKn_N$) has on-chip 50- Ω termination to $SGNDn$ followed by on-chip AC-coupling.
 - The external reference clock driver must be able to drive this termination.
 - The SerDes reference clock input can be either differential or single-ended. See the differential mode and single-ended mode descriptions in [Signal terms definitions](#) for detailed requirements.
- The maximum average current requirement also determines the common mode voltage range.
 - When the SerDes reference clock differential inputs are DC coupled externally with the clock driver chip, the maximum average current allowed for each input pin is 8 mA. In this case, the exact common mode input voltage is not critical as long as it is within the range allowed by the maximum average current of 8 mA because the input is AC-coupled on-chip.
 - This current limitation sets the maximum common mode input voltage to be less than 0.4 V ($0.4\text{ V} \div 50 = 8\text{ mA}$) while the minimum common mode input level is 0.1 V above $SGNDn$. For example, a clock with a 50/50 duty cycle can be produced by a clock driver with output driven by its current source from 0 mA to 16 mA (0-0.8 V), such that each phase of the differential input has a single-ended swing from 0 V to 800 mV with the common mode voltage at 400 mV.
 - If the device driving the $SDn_REF_CLKn_P$ and $SDn_REF_CLKn_N$ inputs cannot drive 50 Ω to $SGNDn$ DC or the drive strength of the clock driver chip exceeds the maximum input current limitations, it must be AC-coupled off-chip.
- The input amplitude requirement is described in detail in the following sections.

3.16.2.3 DC-level requirements for SerDes reference clocks

The DC-level requirements for the SerDes reference clock inputs are different depending on the signaling mode used to connect the clock driver chip and SerDes reference clock inputs, as described below:

- Differential Mode
 - The input amplitude of the differential clock must be between 400 mV and 1600 mV differential peak-to-peak (or between 200 mV and 800 mV differential peak). In other words, each signal wire of the differential pair must have a single-ended swing of less than 800 mV and greater than 200 mV. This requirement is the same for both external DC-coupled or AC-coupled connection.
 - For an external DC-coupled connection, as described in [Figure 30](#), the maximum average current requirements set the requirement for average voltage (common mode voltage) as between 100 mV and 400 mV.
 - This figure shows the SerDes reference clock input requirement for a DC-coupled connection scheme.

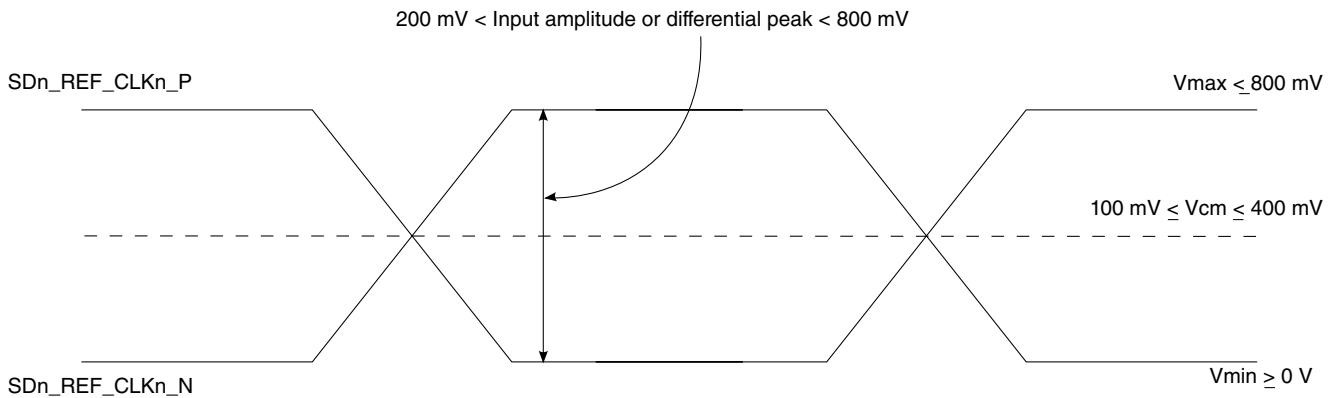

Figure 31. Differential reference clock input DC requirements (external DC-coupled)

- For an external AC-coupled connection, there is no common mode voltage requirement for the clock driver. Because the external AC-coupling capacitor blocks the DC level, the clock driver and the SerDes reference clock receiver operate in different common mode voltages. The SerDes reference clock receiver in this connection scheme has its common mode voltage set to SGND_n. Each signal wire of the differential inputs is allowed to swing below and above the common mode voltage (SGND_n).
- This figure shows the SerDes reference clock input requirement for an AC-coupled connection scheme.



Figure 32. Differential reference clock input DC requirements (external AC-coupled)

- Single-ended mode

- The reference clock can also be single-ended. The SDn_REF_CLKn_P input amplitude (single-ended swing) must be between 400 mV and 800 mV peak-to-peak (from V_{MIN} to V_{MAX}) with SDn_REF_CLKn_N either left unconnected or tied to ground.
- To meet the input amplitude requirement, the reference clock inputs may need to be externally DC- or AC-coupled. For the best noise performance, the reference of the clock could be DC- or AC-coupled into the unused phase (SDn_REF_CLKn_N) through the same source impedance as the clock input (SDn_REF_CLKn_P) in use.
- The SDn_REF_CLKn_P input average voltage must be between 200 and 400 mV.
- This figure shows the SerDes reference clock input requirement for single-ended signaling mode.



Figure 33. Single-ended reference clock input DC requirements

3.16.2.4 AC requirements for SerDes reference clocks

This table provides the AC requirements for SerDes reference clocks for PCI Express protocols running at data rates up to 8 GT/s.

Electrical characteristics

This includes PCI Express (2.5, 5, and 8 GT/s), SGMII (1.25 Gbaud), 2.5 x SGMII (3.125 Gbaud), QSGMII (5 Gbps), and SATA (1.5, 3.0, and 6.0 Gbps). SerDes reference clocks need to be verified by the customer's application design.

Table 65. SD_n_REF_CLK_n_P and SD_n_REF_CLK_n_N input clock requirements (SV_{DD} = 0.9V/1.0 V) ¹

| Parameter | Symbol | Min | Typ | Max | Unit | Notes |
|---|---|------|----------------|------|--------|--------|
| SD _n _REF_CLK _n _P/ SD _n _REF_CLK _n _N frequency range | t _{CLK_REF} | — | 100/125/156.25 | — | MHz | 2 |
| SD _n _REF_CLK _n _P/ SD _n _REF_CLK _n _N clock frequency tolerance | t _{CLK_TOL} | -300 | — | 300 | ppm | 3 |
| SD _n _REF_CLK _n _P/ SD _n _REF_CLK _n _N clock frequency tolerance | t _{CLK_TOL} | -100 | — | 100 | ppm | 4 |
| SD _n _REF_CLK _n _P/ SD _n _REF_CLK _n _N reference clock duty cycle | t _{CLK_DUTY} | 40 | 50 | 60 | % | 5 |
| SD _n _REF_CLK _n _P/ SD _n _REF_CLK _n _N max deterministic peak-to-peak jitter at 10 ⁻⁶ BER | t _{CLK_DJ} | — | — | 42 | ps | — |
| SD _n _REF_CLK _n _P/ SD _n _REF_CLK _n _N total reference clock jitter at 10 ⁻⁶ BER (peak-to-peak jitter at refClk input) | t _{CLK_TJ} | — | — | 86 | ps | 6 |
| SD _n _REF_CLK _n _P/ SD _n _REF_CLK _n _N 10 kHz to 1.5 MHz RMS jitter | t _{REFCLK-LF-RMS} | — | — | 3 | ps RMS | 7 |
| SD _n _REF_CLK _n _P/ SD _n _REF_CLK _n _N > 1.5 MHz to Nyquist RMS jitter | t _{REFCLK-HF-RMS} | — | — | 3.1 | ps RMS | 7 |
| RMS reference clock jitter | t _{REFCLK-RMS-DC} | — | — | 1 | ps RMS | 8 |
| SD _n _REF_CLK _n _P/ SD _n _REF_CLK _n _N rising/falling edge rate | t _{CLKRRR} /t _{CLKFR} | 1 | — | 4 | V/ns | 9 |
| Differential input high voltage | V _{IH} | 200 | — | — | mV | 5 |
| Differential input low voltage | V _{IL} | — | — | -200 | mV | 5 |
| Rising edge rate (SD _n _REF_CLK _n _P) to falling edge rate (SD _n _REF_CLK _n _N) matching | Rise-Fall Matching | — | — | 20 | % | 10, 11 |

Notes:

- For recommended operating conditions, see [Table 3](#).
- Caution:** Only 100, 125, and 156.25 have been tested. In-between values do not work correctly with the rest of the system.
- For PCI Express (2.5, 5 and 8 GT/s).
- For SGMII, 2.5 x SGMII and QSGMII.
- Measurement taken from differential waveform.
- Limits from PCI Express CEM Rev 2.0.
- For PCI Express 5 GT/s, per PCI Express base specification Rev 3.0.
- For PCI Express 8 GT/s, per PCI Express base specification Rev. 3.0.
- Measured from -200 mV to +200 mV on the differential waveform (derived from SD_n_REF_CLK_n_P minus SD_n_REF_CLK_n_N). The signal must be monotonic through the measurement region for rise and fall time. The 400 mV measurement window is centered on the differential zero crossing. See [Figure 34](#).
- Measurement taken from single-ended waveform.

Table 65. SDn_REF_CLKn_P and SDn_REF_CLKn_N input clock requirements (SV_{DD} = 0.9V/1.0 V)¹

| Parameter | Symbol | Min | Typ | Max | Unit | Notes |
|--|--------|-----|-----|-----|------|-------|
| 11. Matching applies to rising edge for SDn_REF_CLKn_P and falling edge rate for SDn_REF_CLKn_N. It is measured using a 200 mV window centered on the median cross point where SDn_REF_CLKn_P rising meets SDn_REF_CLKn_N falling. The median cross point is used to calculate the voltage thresholds that the oscilloscope uses for the edge rate calculations. The rise edge rate of SDn_REF_CLKn_P must be compared to the fall edge rate of SDn_REF_CLKn_N, the maximum allowed difference should not exceed 20% of the slowest edge rate. See Figure 35 . | | | | | | |

This table lists the AC requirements for SerDes reference clocks for protocols running at data rates greater than 8 Gb/s.

This includes XFI (10.3125 Gb/s) SerDes reference clocks to be guaranteed by the customer's application design.

Table 66. Input clock requirements for XFI (10.3125)¹

| Parameter | Symbol | Min | Typ | Max | Unit | Notes |
|---|-----------------------|------|--------|------|--------|-------|
| Frequency range | t _{CLK_REF} | — | 156.25 | — | MHz | 2 |
| Clock frequency tolerance | t _{CLK_TOL} | -100 | — | 100 | ppm | — |
| Reference clock duty cycle | t _{CLK_DUTY} | 40 | 50 | 60 | % | 3 |
| Single side band noise | @ 1 kHz | — | — | -85 | dBC/Hz | 4 |
| Single side band noise | @ 10 kHz | — | — | -108 | dBC/Hz | 4 |
| Single side band noise | @ 100 kHz | — | — | -128 | dBC/Hz | 4 |
| Single side band noise | @ 1 MHz | — | — | -138 | dBC/Hz | 4 |
| Single side band noise | @ 10MHz | — | — | -138 | dBC/Hz | 4 |
| Random jitter (1.2 MHz to 15 MHz) | t _{CLK_RJ} | — | — | 0.8 | ps | — |
| Total reference clock jitter at 10 ⁻¹² BER (1.2 MHz to 15 MHz) | t _{CLK_TJ} | — | — | 11 | ps | — |
| Spurious noise (1.2 MHz to 15 MHz) | — | — | — | -75 | dBC | — |

Notes:

- For recommended operating conditions, see [Table 3](#).
- Caution:** Only 156.25 have been tested. Inbetween values do not work correctly with the rest of the system.
- Measurement taken from differential waveform.
- Per XFP Spec. Rev 4.5, the Module Jitter Generation spec at XFI Optical Output is 10mUI (RMS) and 100 mUI (p-p). In the CDR mode the host is contributing 7 mUI (RMS) and 50 mUI (p-p) jitter.

This figure shows the differential measurement points for rise and fall time.

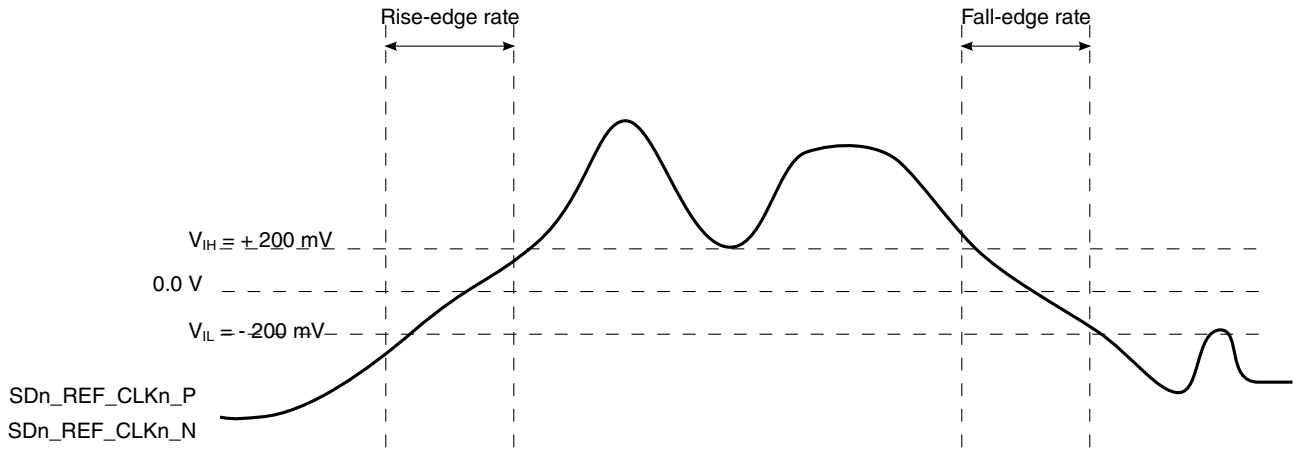

Figure 34. Differential measurement points for rise and fall time

This figure shows the single-ended measurement points for rise and fall time matching.

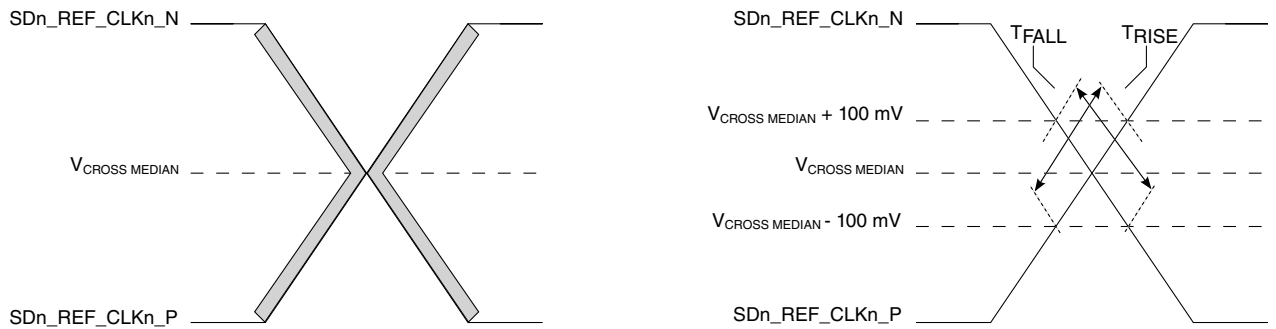

Figure 35. Single-ended measurement points for rise and fall time matching

3.16.3 SerDes transmitter and receiver reference circuits

This figure shows the reference circuits for SerDes data lane's transmitter and receiver.



Figure 36. SerDes transmitter and receiver reference circuits

The DC and AC specifications of the SerDes data lanes are defined in each interface protocol section below based on the application usage:

- [PCI Express](#)
- [Serial ATA \(SATA\) interface](#)
- [SGMII interface](#)
- [QSGMII interface](#)
- [XFI interface](#)

Note that an external AC-coupling capacitor is required for the above serial transmission protocols with the capacitor value defined in the specification of each protocol section.

3.16.4 PCI Express

This section describes the clocking dependencies, as well as the DC and AC electrical specifications for the PCI Express bus.

3.16.4.1 Clocking dependencies

The ports on the two ends of a link must transmit data at a rate that is within 600 ppm of each other at all times. This is specified to allow bit rate clock sources with a ± 300 ppm tolerance.

3.16.4.2 PCI Express clocking requirements for SD2_REF_CLK n _P and SD2_REF_CLK n _N

SerDes 2 (SD2_REF_CLK[1:2]_P and SD2_REF_CLK[1:2]_N) may be used for various SerDes PCI Express configurations based on the RCW configuration field SRDS_PRTCL. PCI Express is supported on SerDes 2.

For more information on these specifications, see [SerDes reference clocks](#).

3.16.4.3 PCI Express DC physical layer specifications

This section contains the DC specifications for the physical layer of PCI Express on this chip.

3.16.4.3.1 PCI Express DC physical layer transmitter specifications

This section discusses the PCI Express DC physical layer transmitter specifications for 2.5 GT/s, 5 GT/s, and 8 GT/s.

This table defines the PCI Express 2.0 (2.5 GT/s) DC specifications for the differential output at all transmitters. The parameters are specified at the component pins.

Electrical characteristics

Table 67. PCI Express 2.0 (2.5 GT/s) differential transmitter output DC specifications ($XV_{DD} = 1.35\text{ V}$)¹

| Parameter | Symbol | Min | Typical | Max | Units | Notes |
|--|-------------------|-----|---------|------|----------|--|
| Differential peak-to-peak output voltage | $V_{TX-DIFFp-p}$ | 800 | 1000 | 1200 | mV | $V_{TX-DIFFp-p} = 2 \times V_{TX-D+} - V_{TX-D-} $ |
| De-emphasized differential output voltage (ratio) | $V_{TX-DE-RATIO}$ | 3.0 | 3.5 | 4.0 | dB | Ratio of the $V_{TX-DIFFp-p}$ of the second and following bits after a transition divided by the $V_{TX-DIFFp-p}$ of the first bit after a transition. |
| DC differential transmitter impedance | $Z_{TX-DIFF-DC}$ | 80 | 100 | 120 | Ω | Transmitter DC differential mode low Impedance |
| Transmitter DC impedance | Z_{TX-DC} | 40 | 50 | 60 | Ω | Required transmitter D+ as well as D- DC Impedance during all states |
| Notes: | | | | | | |
| 1. For recommended operating conditions, see Table 3 . | | | | | | |

This table defines the PCI Express 2.0 (5 GT/s) DC specifications for the differential output at all transmitters. The parameters are specified at the component pins.

Table 68. PCI Express 2.0 (5 GT/s) differential transmitter output DC specifications ($XV_{DD} = 1.35\text{ V}$)¹

| Parameter | Symbol | Min | Typical | Max | Units | Notes |
|--|-------------------------|-----|---------|------|----------|--|
| Differential peak-to-peak output voltage | $V_{TX-DIFFp-p}$ | 800 | 1000 | 1200 | mV | $V_{TX-DIFFp-p} = 2 \times V_{TX-D+} - V_{TX-D-} $ |
| Low power differential peak-to-peak output voltage | $V_{TX-DIFFp-p_low}$ | 400 | 500 | 1200 | mV | $V_{TX-DIFFp-p} = 2 \times V_{TX-D+} - V_{TX-D-} $ |
| De-emphasized differential output voltage (ratio) | $V_{TX-DE-RATIO-3.5dB}$ | 3.0 | 3.5 | 4.0 | dB | Ratio of the $V_{TX-DIFFp-p}$ of the second and following bits after a transition divided by the $V_{TX-DIFFp-p}$ of the first bit after a transition. |
| De-emphasized differential output voltage (ratio) | $V_{TX-DE-RATIO-6.0dB}$ | 5.5 | 6.0 | 6.5 | dB | Ratio of the $V_{TX-DIFFp-p}$ of the second and following bits after a transition divided by the $V_{TX-DIFFp-p}$ of the first bit after a transition. |
| DC differential transmitter impedance | $Z_{TX-DIFF-DC}$ | 80 | 100 | 120 | Ω | Transmitter DC differential mode low impedance |
| Transmitter DC Impedance | Z_{TX-DC} | 40 | 50 | 60 | Ω | Required transmitter D+ as well as D- DC impedance during all states |
| Notes: | | | | | | |
| 1. For recommended operating conditions, see Table 3 . | | | | | | |

This table defines the PCI Express 3.0 (8 GT/s) DC characteristics for the differential output at all transmitters. The parameters are specified at the component pins.

Table 69. PCI Express 3.0 (8 GT/s) differential transmitter output DC characteristics ($V_{DD} = 1.35\text{ V}$)³

| Parameter | Symbol | Min | Typical | Max | Units | Notes |
|---|-------------------------|-----|---------|------|----------|--|
| Full swing transmitter voltage with no TX Eq | $V_{TX-FS-NO-EQ}$ | 800 | — | 1300 | mVp-p | See Note 1. |
| Reduced swing transmitter voltage with no TX Eq | $V_{TX-RS-NO-EQ}$ | 400 | — | 1300 | mV | See Note 1. |
| De-emphasized differential output voltage (ratio) | $V_{TX-DE-RATIO-3.5dB}$ | 3.0 | 3.5 | 4.0 | dB | — |
| De-emphasized differential output voltage (ratio) | $V_{TX-DE-RATIO-6.0dB}$ | 5.5 | 6.0 | 6.5 | dB | — |
| Minimum swing during EIEOS for full swing | $V_{TX-EIEOS-FS}$ | 250 | — | — | mVp-p | See Note 2 |
| Minimum swing during EIEOS for reduced swing | $V_{TX-EIEOS-RS}$ | 232 | — | — | mVp-p | See Note 2 |
| DC differential transmitter impedance | $Z_{TX-DIFF-DC}$ | 80 | 100 | 120 | Ω | Transmitter DC differential mode low impedance |
| Transmitter DC Impedance | Z_{TX-DC} | 40 | 50 | 60 | Ω | Required transmitter D+ as well as D- DC impedance during all states |

Notes:

1. Voltage measurements for $V_{TX-FS-NO-EQ}$ and $V_{TX-RS-NO-EQ}$ are made using the 64-zeroes/64-ones pattern in the compliance pattern.
2. Voltage limits comprehend both full swing and reduced swing modes. The transmitter must reject any changes that would violate this specification. The maximum level is covered in the $V_{TX-FS-NO-EQ}$ measurement which represents the maximum peak voltage the transmitter can drive. The $V_{TX-EIEOS-FS}$ and $V_{TX-EIEOS-RS}$ voltage limits are imposed to guarantee the EIEOS threshold of 175 mV_{p-p} at the receiver pin. This parameter is measured using the actual EIEOS pattern that is part of the compliance pattern and then removing the ISI contribution of the breakout channel.
3. For recommended operating conditions, see [Table 3](#).

3.16.4.3.2 PCI Express DC physical layer receiver specifications

This section discusses the PCI Express DC physical layer receiver specifications for 2.5 GT/s, 5 GT/s, and 8 GT/s.

This table defines the DC specifications for the PCI Express 2.0 (2.5 GT/s) differential input at all receivers. The parameters are specified at the component pins.

Table 70. PCI Express 2.0 (2.5 GT/s) differential receiver input DC specifications ($SV_{DD} = 0.9\text{V}/1.0\text{ V}$)⁴

| Parameter | Symbol | Min | Typ | Max | Units | Notes |
|---|------------------|-----|------|------|-------|---|
| Differential input peak-to-peak voltage | $V_{RX-DIFFp-p}$ | 175 | 1000 | 1200 | mV | $V_{RX-DIFFp-p} = 2 \times V_{RX-D+} - V_{RX-D-} $ See Note 1. |

Table continues on the next page...

Table 70. PCI Express 2.0 (2.5 GT/s) differential receiver input DC specifications (SV_{DD} = 0.9V/1.0 V)⁴ (continued)

| Parameter | Symbol | Min | Typ | Max | Units | Notes |
|----------------------------------|----------------------------------|-----|-----|-----|-------|---|
| DC differential input impedance | Z _{RX-DIFF-DC} | 80 | 100 | 120 | Ω | Receiver DC differential mode impedance. See Note 2 |
| DC input impedance | Z _{RX-DC} | 40 | 50 | 60 | Ω | Required receiver D+ as well as D- DC Impedance (50 ± 20% tolerance). See Notes 1 and 2. |
| Powered down DC input impedance | Z _{RX-HIGH-IMP-DC} | 50 | - | - | kΩ | Required receiver D+ as well as D- DC Impedance when the receiver terminations do not have power. See Note 3. |
| Electrical idle detect threshold | V _{RX-IDLE-DET-DIFFp-p} | 65 | - | 175 | mV | V _{RX-IDLE-DET-DIFFp-p} = 2 × V _{RX-D+} - V _{RX-D-} Measured at the package pins of the receiver |

Notes:

1. Measured at the package pins with a test load of 50Ω to GND on each pin.
2. Impedance during all LTSSM states. When transitioning from a fundamental reset to detect (the initial state of the LTSSM) there is a 5 ms transition time before receiver termination values must be met on all unconfigured lanes of a port.
3. The receiver DC common mode impedance that exists when no power is present or fundamental reset is asserted. This helps ensure that the receiver detect circuit does not falsely assume a receiver is powered on when it is not. This term must be measured at 300 mV above the receiver ground.
4. For recommended operating conditions, see [Table 3](#).

This table defines the DC specifications for the PCI Express 2.0 (5 GT/s) differential input at all receivers. The parameters are specified at the component pins.

Table 71. PCI Express 2.0 (5 GT/s) differential receiver input DC specifications (SV_{DD} = 0.9V/1.0 V)⁴

| Parameter | Symbol | Min | Typ | Max | Units | Notes |
|---|----------------------------------|-----|------|------|-------|---|
| Differential input peak-to-peak voltage | V _{RX-DIFFp-p} | 120 | 1000 | 1200 | mV | V _{RX-DIFFp-p} = 2 × V _{RX-D+} - V _{RX-D-} See Note 1. |
| DC differential input impedance | Z _{RX-DIFF-DC} | 80 | 100 | 120 | Ω | Receiver DC differential mode impedance. See Note 2 |
| DC input impedance | Z _{RX-DC} | 40 | 50 | 60 | Ω | Required receiver D+ as well as D- DC Impedance (50 ± 20% tolerance). See Notes 1 and 2. |
| Powered down DC input impedance | Z _{RX-HIGH-IMP-DC} | 50 | - | - | kΩ | Required receiver D+ as well as D- DC Impedance when the receiver terminations do not have power. See Note 3. |
| Electrical idle detect threshold | V _{RX-IDLE-DET-DIFFp-p} | 65 | - | 175 | mV | V _{RX-IDLE-DET-DIFFp-p} = 2 × V _{RX-D+} - V _{RX-D-} Measured at the package pins of the receiver |

Table continues on the next page...

Table 71. PCI Express 2.0 (5 GT/s) differential receiver input DC specifications (SV_{DD} = 0.9V/1.0 V)⁴ (continued)

| Parameter | Symbol | Min | Typ | Max | Units | Notes |
|---|--------|-----|-----|-----|-------|-------|
| Notes: | | | | | | |
| 1. Measured at the package pins with a test load of 50 Ω to GND on each pin. | | | | | | |
| 2. Impedance during all LTSSM states. When transitioning from a fundamental reset to detect (the initial state of the LTSSM) there is a 5 ms transition time before receiver termination values must be met on all unconfigured lanes of a port. | | | | | | |
| 3. The receiver DC common mode impedance that exists when no power is present or fundamental reset is asserted. This helps ensure that the receiver detect circuit does not falsely assume a receiver is powered on when it is not. This term must be measured at 300 mV above the receiver ground. | | | | | | |
| 4. For recommended operating conditions, see Table 3 . | | | | | | |

This table defines the DC characteristics for the PCI Express 3.0 (8 GT/s) differential input at all receivers. The parameters are specified at the component pins.

Table 72. PCI Express 3.0 (8 GT/s) differential receiver input DC characteristics (SV_{DD} = 0.9V/1.0 V)⁶

| Characteristic | Symbol | Min | Typ | Max | Units | Notes |
|----------------------------------|----------------------------------|-----|-----|-----|-------|--|
| DC differential input impedance | Z _{RX-DIFF-DC} | 80 | 100 | 120 | Ω | Receiver DC differential mode impedance. See Note 2 |
| DC input impedance | Z _{RX-DC} | 40 | 50 | 60 | Ω | Required receiver D+ as well as D-DC Impedance (50 ± 20% tolerance). See Notes 1 and 2. |
| Powered down DC input impedance | Z _{RX-HIGH-IMP-DC} | 50 | — | — | kΩ | Required receiver D+ as well as D-DC Impedance when the receiver terminations do not have power. See Note 3. |
| Generator launch voltage | V _{RX-LAUNCH-8G} | — | 800 | — | mV | Measured at TP1 per PCI Express base spec. rev 3.0 |
| Eye height (-20dB Channel) | V _{RX-SV-8G} | 25 | — | — | mV | Measured at TP2P per PCI Express base spec. rev 3.0. See Notes 4, 5 |
| Eye height (-12dB Channel) | V _{RX-SV-8G} | 50 | — | — | mV | Measured at TP2P per PCI Express base spec. rev 3.0. See Notes 4, 5 |
| Eye height (-3dB Channel) | V _{RX-SV-8G} | 200 | — | — | mV | Measured at TP2P per PCI Express base spec. rev 3.0. See Notes 4, 5 |
| Electrical idle detect threshold | V _{RX-IDLE-DET-DIFFp-p} | 65 | — | 175 | mV | V _{RX-IDLE-DET-DIFFp-p} = 2 × V _{RX-D+} - V _{RX-D-} Measured at the package pins of the receiver |

Notes:

1. Measured at the package pins with a test load of 50 Ω to GND on each pin.
2. Impedance during all LTSSM states. When transitioning from a fundamental reset to detect (the initial state of the LTSSM) there is a 5 ms transition time before receiver termination values must be met on all unconfigured lanes of a port.
3. The receiver DC common mode impedance that exists when no power is present or fundamental reset is asserted. This helps ensure that the receiver detect circuit does not falsely assume a receiver is powered on when it is not. This term must be measured at 300 mV above the receiver ground.

Table 72. PCI Express 3.0 (8 GT/s) differential receiver input DC characteristics (SV_{DD} = 0.9V/1.0 V)⁶

| Characteristic | Symbol | Min | Typ | Max | Units | Notes |
|---|--------|-----|-----|-----|-------|-------|
| 4. V _{RX-SV-8G} is tested at three different voltages to ensure the receiver device under test is capable of equalizing over a range of channel loss profiles. The "SV" in the parameter names refers to stressed voltage. | | | | | | |
| 5. V _{RX-SV-8G} is referenced to TP2P and is obtained after post processing data captured at TP2. | | | | | | |
| 6. For recommended operating conditions, see Table 3 . | | | | | | |

3.16.4.4 PCI Express AC physical layer specifications

This section describes the AC specifications for the physical layer of PCI Express on this device.

3.16.4.4.1 PCI Express AC physical layer transmitter specifications

This section describes the PCI Express AC physical layer transmitter specifications for 2.5 GT/s, 5 GT/s, and 8 GT/s.

This table defines the PCI Express 2.0 (2.5 GT/s) AC specifications for the differential output at all transmitters. The parameters are specified at the component pins. The AC timing specifications do not include RefClk jitter.

Table 73. PCI Express 2.0 (2.5 GT/s) differential transmitter output AC specifications⁴

| Parameter | Symbol | Min | Typ | Max | Units | Notes |
|--|--|--------|-----|--------|-------|--|
| Unit interval | UI | 399.88 | 400 | 400.12 | ps | Each UI is 400 ps ± 300 ppm. UI does not account for spread-spectrum clock dictated variations. |
| Minimum transmitter eye width | T _{TX-EYE} | 0.75 | - | - | UI | The maximum transmitter jitter can be derived as T _{TX-MAX-JITTER} = 1 - T _{TX-EYE} = 0.25 UI. Does not include spread-spectrum or RefCLK jitter. Includes device random jitter at 10 ⁻¹² . See Notes 1 and 2. |
| Maximum time between the jitter median and maximum deviation from the median | T _{TX-EYE-MEDIAN-to-MAX-JITTER} | - | - | 0.125 | UI | Jitter is defined as the measurement variation of the crossing points (V _{TX-DIFFP-P} = 0 V) in relation to a recovered transmitter UI. A recovered transmitter UI is calculated over 3500 consecutive unit intervals of sample data. Jitter is measured using all edges of the 250 consecutive UI in the center of the 3500 UI used for calculating the transmitter UI. See Notes 1 and 2. |
| AC coupling capacitor | C _{TX} | 75 | - | 200 | nF | All transmitters must be AC coupled. The AC coupling is required either within the media or within the transmitting component itself. See Note 3. |

Table continues on the next page...

**Table 73. PCI Express 2.0 (2.5 GT/s) differential transmitter output AC specifications⁴
(continued)**

| Parameter | Symbol | Min | Typ | Max | Units | Notes |
|--|--------|-----|-----|-----|-------|-------|
| Notes: | | | | | | |
| 1. Specified at the measurement point into a timing and voltage test load as shown in Figure 38 and measured over any 250 consecutive transmitter UIs. | | | | | | |
| 2. A $T_{TX-EYE} = 0.75$ UI provides for a total sum of deterministic and random jitter budget of $T_{TX-JITTER-MAX} = 0.25$ UI for the transmitter collected over any 250 consecutive transmitter UIs. The $T_{TX-EYE-MEDIAN-to-MAX-JITTER}$ median is less than half of the total transmitter jitter budget collected over any 250 consecutive transmitter UIs. It must be noted that the median is not the same as the mean. The jitter median describes the point in time where the number of jitter points on either side is approximately equal as opposed to the averaged time value. | | | | | | |
| 3. The chip's SerDes transmitter does not have C_{TX} built-in. An external AC coupling capacitor is required. | | | | | | |
| 4. For recommended operating conditions, see Table 3 . | | | | | | |

This table defines the PCI Express 2.0 (5 GT/s) AC specifications for the differential output at all transmitters. The parameters are specified at the component pins. The AC timing specifications do not include RefClk jitter.

Table 74. PCI Express 2.0 (5 GT/s) differential transmitter output AC specifications³

| Parameter | Symbol | Min | Typ | Max | Units | Notes |
|--|-------------------|--------|--------|--------|-------|---|
| Unit Interval | UI | 199.94 | 200.00 | 200.06 | ps | Each UI is 200 ps \pm 300 ppm. UI does not account for spread-spectrum clock dictated variations. |
| Minimum transmitter eye width | T_{TX-EYE} | 0.75 | - | - | UI | The maximum transmitter jitter can be derived as: $T_{TX-MAX-JITTER} = 1 - T_{TX-EYE} = 0.25$ UI. See Note 1. |
| Transmitter RMS deterministic jitter > 1.5 MHz | $T_{TX-HF-DJ-DD}$ | - | - | 0.15 | ps | - |
| Transmitter RMS deterministic jitter < 1.5 MHz | $T_{TX-LF-RMS}$ | - | 3.0 | - | ps | Reference input clock RMS jitter (< 1.5 MHz) at pin < 1 ps |
| AC coupling capacitor | C_{TX} | 75 | - | 200 | nF | All transmitters must be AC coupled. The AC coupling is required either within the media or within the transmitting component itself. See Note 2. |
| Notes: | | | | | | |
| 1. Specified at the measurement point into a timing and voltage test load as shown in Figure 38 and measured over any 250 consecutive transmitter UIs. | | | | | | |
| 2. The chip's SerDes transmitter does not have C_{TX} built-in. An external AC coupling capacitor is required. | | | | | | |
| 3. For recommended operating conditions, see Table 3 . | | | | | | |

This table defines the PCI Express 3.0 (8 GT/s) AC specifications for the differential output at all transmitters. The parameters are specified at the component pins. The AC timing specifications do not include RefClk jitter.

Table 75. PCI Express 3.0 (8 GT/s) differential transmitter output AC specifications⁴

| Parameter | Symbol | Min | Typ | Max | Units | Notes |
|--|--------------------------|----------|--------|----------|--------|---|
| Unit Interval | UI | 124.9625 | 125.00 | 125.0375 | ps | Each UI is 125 ps \pm 300 ppm. UI does not account for spread-spectrum clock dictated variations. |
| Transmitter uncorrelated total jitter | T _{TX-UTJ} | — | — | 31.25 | ps p-p | — |
| Transmitter uncorrelated deterministic jitter | T _{TX-UDJ-DD} | — | — | 12 | ps p-p | — |
| Total uncorrelated pulse width jitter (PWJ) | T _{TX-UPW-TJ} | — | — | 24 | ps p-p | See Note 1, 2 |
| Deterministic data dependent jitter (DjDD) uncorrelated pulse width jitter (PWJ) | T _{TX-UPW-DJDD} | — | — | 10 | ps p-p | See Note 1, 2 |
| Data dependent jitter | T _{TX-DDJ} | — | — | 18 | ps p-p | See Note 2 |
| AC coupling capacitor | C _{TX} | 176 | — | 265 | nF | All transmitters must be AC coupled. The AC coupling is required either within the media or within the transmitting component itself. See Note 3. |

Notes:

1. PWJ parameters shall be measured after data dependent jitter (DDJ) separation.
2. Measured with optimized preset value after de-embedding to transmitter pin.
3. The chip's SerDes transmitter does not have C_{TX} built-in. An external AC coupling capacitor is required.
4. For recommended operating conditions, see [Table 3](#).

3.16.4.4.2 PCI Express AC physical layer receiver specifications

This section discusses the PCI Express AC physical layer receiver specifications for 2.5 GT/s, 5 GT/s, and 8 GT/s.

This table defines the AC specifications for the PCI Express 2.0 (2.5 GT/s) differential input at all receivers. The parameters are specified at the component pins. The AC timing specifications do not include RefClk jitter.

Table 76. PCI Express 2.0 (2.5 GT/s) differential receiver input AC specifications⁴

| Parameter | Symbol | Min | Typ | Max | Units | Notes |
|----------------------------|---------------------|--------|--------|--------|-------|--|
| Unit Interval | UI | 399.88 | 400.00 | 400.12 | ps | Each UI is 400 ps \pm 300 ppm. UI does not account for spread-spectrum clock dictated variations. |
| Minimum receiver eye width | T _{RX-EYE} | 0.4 | - | - | UI | The maximum interconnect media and transmitter jitter that can be tolerated by the receiver can be derived as T _{RX-MAX-JITTER} = 1 - T _{RX-EYE} = 0.6 UI. See Notes 1 and 2. |

Table continues on the next page...

**Table 76. PCI Express 2.0 (2.5 GT/s) differential receiver input AC specifications⁴
(continued)**

| Parameter | Symbol | Min | Typ | Max | Units | Notes |
|--|-----------------------------------|-----|-----|-----|-------|---|
| Maximum time between the jitter median and maximum deviation from the median. | $T_{RX-EYE-MEDIAN-to-MAX-JITTER}$ | - | - | 0.3 | UI | Jitter is defined as the measurement variation of the crossing points ($V_{RX-DIFFp-p} = 0$ V) in relation to a recovered transmitter UI. A recovered transmitter UI is calculated over 3500 consecutive unit intervals of sample data. Jitter is measured using all edges of the 250 consecutive UI in the center of the 3500 UI used for calculating the transmitter UI. See Notes 1, 2 and 3. |
| Notes: | | | | | | |
| <p>1. Specified at the measurement point and measured over any 250 consecutive UIs. The test load in Figure 38 must be used as the receiver device when taking measurements. If the clocks to the receiver and transmitter are not derived from the same reference clock, the transmitter UI recovered from 3500 consecutive UI must be used as a reference for the eye diagram.</p> <p>2. A $T_{RX-EYE} = 0.40$ UI provides for a total sum of 0.60 UI deterministic and random jitter budget for the transmitter and interconnect collected any 250 consecutive UIs. The $T_{RX-EYE-MEDIAN-to-MAX-JITTER}$ specification ensures a jitter distribution in which the median and the maximum deviation from the median is less than half of the total. UI jitter budget collected over any 250 consecutive transmitter UIs. It must be noted that the median is not the same as the mean. The jitter median describes the point in time where the number of jitter points on either side is approximately equal as opposed to the averaged time value. If the clocks to the receiver and transmitter are not derived from the same reference clock, the transmitter UI recovered from 3500 consecutive UI must be used as the reference for the eye diagram.</p> <p>3. It is recommended that the recovered transmitter UI is calculated using all edges in the 3500 consecutive UI interval with a fit algorithm using a minimization merit function. Least squares and median deviation fits have worked well with experimental and simulated data.</p> <p>4. For recommended operating conditions, see Table 3.</p> | | | | | | |

This table defines the AC specifications for the PCI Express 2.0 (5 GT/s) differential input at all receivers. The parameters are specified at the component pins. The AC timing specifications do not include RefClk jitter.

Table 77. PCI Express 2.0 (5 GT/s) differential receiver input AC specifications¹

| Parameter | Symbol | Min | Typ | Max | Units | Notes |
|--|-------------------|--------|--------|--------|-------|---|
| Unit Interval | UI | 199.40 | 200.00 | 200.06 | ps | Each UI is 200 ps \pm 300 ppm. UI does not account for spread-spectrum clock dictated variations. |
| Max receiver inherent timing error | $T_{RX-TJ-CC}$ | - | - | 0.4 | UI | The maximum inherent total timing error for common RefClk receiver architecture |
| Max receiver inherent deterministic timing error | $T_{RX-DJ-DD-CC}$ | - | - | 0.30 | UI | The maximum inherent deterministic timing error for common RefClk receiver architecture |
| Note: | | | | | | |
| 1. For recommended operating conditions, see Table 3 . | | | | | | |

Electrical characteristics

This table defines the AC specifications for the PCI Express 3.0 (8 GT/s) differential input at all receivers. The parameters are specified at the component pins. The AC timing specifications do not include RefClk jitter.

Table 78. PCI Express 3.0 (8 GT/s) differential receiver input AC specifications⁵

| Parameter | Symbol | Min | Typ | Max | Units | Notes |
|--------------------------------|---------------------|----------|--------|----------|--------|---|
| Unit Interval | UI | 124.9625 | 125.00 | 125.0375 | ps | Each UI is 125 ps \pm 300 ppm. UI does not account for spread-spectrum clock dictated variations. See Note 1. |
| Eye Width at TP2P | $T_{RX-SV-8G}$ | 0.3 | — | 0.35 | UI | See Note 1 |
| Differential mode interference | $V_{RX-SV-DIFF-8G}$ | 14 | — | — | mV | Frequency = 2.1GHz. See Note 2. |
| Sinusoidal Jitter at 100 MHz | $T_{RX-SV-SJ-8G}$ | — | — | 0.1 | UI p-p | Fixed at 100 MHz. See Note 3. |
| Random Jitter | $T_{RX-SV-RJ-8G}$ | — | — | 2.0 | ps RMS | Random jitter spectrally flat before filtering. See Note 4. |

Note:

- $T_{RX-SV-8G}$ is referenced to TP2P and obtained after post processing data captured at TP2. $T_{RX-SV-8G}$ includes the effects of applying the behavioral receiver model and receiver behavioral equalization.
- $V_{RX-SV-DIFF-8G}$ voltage may need to be adjusted over a wide range for the different loss calibration channels.
- The sinusoidal jitter in the total jitter tolerance may have any amplitude and frequency as shown in Figure 37.
- Random jitter (Rj) is applied over the following range: The low frequency limit may be between 1.5 and 10 MHz, and the upper limit is 1.0 GHz. See Figure 37 for details. Rj may be adjusted to meet the 0.3 UI value for $T_{RX-SV-8G}$.
- For recommended operating conditions, see Table 3.



Figure 37. Swept sinusoidal jitter mask

3.16.4.5 Test and measurement load

The AC timing and voltage parameters must be verified at the measurement point. The package pins of the device must be connected to the test/measurement load within 0.2 inches of that load, as shown in the following figure.

NOTE

The allowance of the measurement point to be within 0.2 inches of the package pins is meant to acknowledge that package/board routing may benefit from D+ and D- not being exactly matched in length at the package pin boundary. If the vendor does not explicitly state where the measurement point is located, the measurement point is assumed to be the D+ and D- package pins.

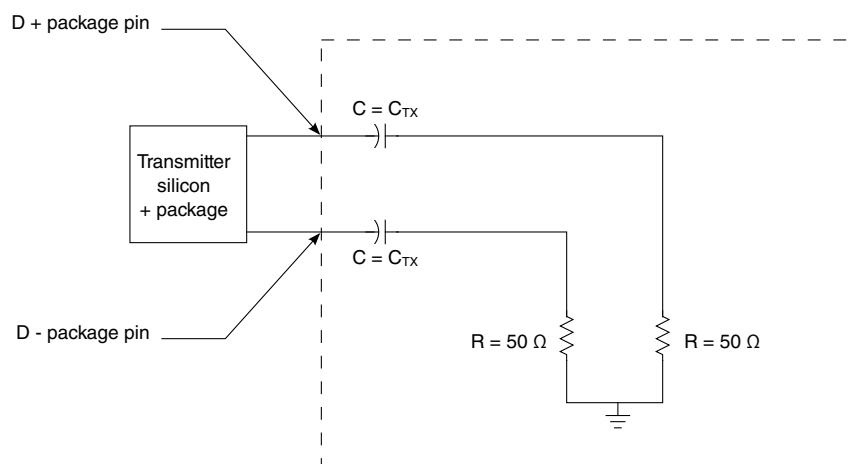

Figure 38. Test and measurement load

3.16.5 Serial ATA (SATA) interface

This section describes the DC and AC electrical specifications for the SATA interface.

3.16.5.1 SATA DC electrical characteristics

This section describes the DC electrical characteristics for SATA.

3.16.5.1.1 SATA DC transmitter output characteristics

This table provides the differential transmitter output DC characteristics for the SATA interface at Gen1i/1m or 1.5 Gbits/s transmission.

Electrical characteristics

Table 79. Gen1i/1m 1.5 G transmitter DC specifications ($XV_{DD} = 1.35\text{ V}$)³

| Parameter | Symbol | Min | Typ | Max | Units | Notes |
|--------------------------------|-----------------------------|-----|-----|-----|----------|-------|
| Tx differential output voltage | $V_{\text{SATA_TXDIFF}}$ | 400 | 500 | 600 | mV p-p | 1 |
| Tx differential pair impedance | $Z_{\text{SATA_TXDIFFIM}}$ | 85 | 100 | 115 | Ω | 2 |

Notes:

1. Terminated by 50 Ω load.
2. DC impedance.
3. For recommended operating conditions, see [Table 3](#).

This table provides the differential transmitter output DC characteristics for the SATA interface at Gen2i/2m or 3.0 Gbits/s transmission.

Table 80. Gen 2i/2m 3 G transmitter DC specifications ($XV_{DD} = 1.35\text{ V}$)²

| Parameter | Symbol | Min | Typ | Max | Units | Notes |
|---|-----------------------------|-----|-----|-----|----------|-------|
| Transmitter differential output voltage | $V_{\text{SATA_TXDIFF}}$ | 400 | — | 700 | mV p-p | 1 |
| Transmitter differential pair impedance | $Z_{\text{SATA_TXDIFFIM}}$ | 85 | 100 | 115 | Ω | — |

Notes:

1. Terminated by 50 Ω load.
2. For recommended operating conditions, see [Table 3](#).

This table provides the differential transmitter output DC characteristics for the SATA interface at Gen 3i transmission.

Table 81. Gen 3i transmitter DC specifications ($XV_{DD} = 1.35\text{ V}$)²

| Parameter | Symbol | Min | Typ | Max | Units | Notes |
|---|-----------------------------|-----|-----|-----|----------|-------|
| Transmitter differential output voltage | $V_{\text{SATA_TXDIFF}}$ | 240 | — | 900 | mV p-p | 1 |
| Transmitter differential pair impedance | $Z_{\text{SATA_TXDIFFIM}}$ | 85 | 100 | 115 | Ω | — |

Notes:

1. Terminated by 50 Ω load.
2. For recommended operating conditions, see [Table 3](#).

3.16.5.1.2 SATA DC receiver input characteristics

This table provides the Gen1i/1m or 1.5 Gbits/s differential receiver input DC characteristics for the SATA interface.

Table 82. Gen1i/1m 1.5 G receiver input DC specifications ($SV_{DD} = 0.9\text{ V} / 1.0\text{ V}$)³

| Parameter | Symbol | Min | Typical | Max | Units | Notes |
|---------------------------------------|--------------------|-----|---------|-----|----------|-------|
| Differential input voltage | V_{SATA_RXDIFF} | 240 | 500 | 600 | mV p-p | 1 |
| Differential receiver input impedance | Z_{SATA_RXSEIM} | 85 | 100 | 115 | Ω | 2 |
| OOB signal detection threshold | V_{SATA_OOB} | 50 | 120 | 240 | mV p-p | — |

Notes:

1. Voltage relative to common of either signal comprising a differential pair.
2. DC impedance.
3. For recommended operating conditions, see [Table 3](#).

This table provides the Gen2i/2m or 3 Gbits/s differential receiver input DC characteristics for the SATA interface.

Table 83. Gen2i/2m 3 G receiver input DC specifications ($SV_{DD} = 0.9\text{ V} / 1.0\text{ V}$)³

| Parameter | Symbol | Min | Typical | Max | Units | Notes |
|---------------------------------------|--------------------|-----|---------|-----|----------|-------|
| Differential input voltage | V_{SATA_RXDIFF} | 240 | — | 750 | mV p-p | 1 |
| Differential receiver input impedance | Z_{SATA_RXSEIM} | 85 | 100 | 115 | Ω | 2 |
| OOB signal detection threshold | V_{SATA_OOB} | 75 | 120 | 240 | mV p-p | 2 |

Notes:

1. Voltage relative to common of either signal comprising a differential pair.
2. DC impedance.
3. For recommended operating conditions, see [Table 3](#).

This table provides the Gen 3i differential receiver input DC characteristics for the SATA interface.

Table 84. Gen 3i receiver input DC specifications ($SV_{DD} = 0.9\text{ V} / 1.0\text{ V}$)³

| Parameter | Symbol | Min | Typical | Max | Units | Notes |
|---------------------------------------|--------------------|-----|---------|------|----------|-------|
| Differential input voltage | V_{SATA_RXDIFF} | 240 | — | 1000 | mV p-p | 1 |
| Differential receiver input impedance | Z_{SATA_RXSEIM} | 85 | 100 | 115 | Ω | 2 |
| OOB signal detection threshold | — | 75 | 120 | 200 | mV p-p | — |

Notes:

1. Voltage relative to common of either signal comprising a differential pair.
2. DC impedance.
3. For recommended operating conditions, see [Table 3](#).

3.16.5.2 SATA AC timing specifications

This section describes the SATA AC timing specifications.

3.16.5.2.1 AC requirements for SATA REF_CLK

This table provides the AC requirements for the SATA reference clock. These requirements must be guaranteed by the customer's application design.

Table 85. SATA reference clock input requirements⁶

| Parameter | Symbol | Min | Typ | Max | Unit | Notes |
|---|-----------------------|------|---------|------|------|---------|
| SDn_REF_CLK1_P/SDn_REF_CLK1_N frequency range | t _{CLK_REF} | — | 100/125 | — | MHz | 1 |
| SDn_REF_CLK1_P/SDn_REF_CLK1_N clock frequency tolerance | t _{CLK_TOL} | -350 | — | +350 | ppm | — |
| SDn_REF_CLK1_P/SDn_REF_CLK1_N reference clock duty cycle | t _{CLK_DUTY} | 40 | 50 | 60 | % | 5 |
| SDn_REF_CLK1_P/SDn_REF_CLK1_N cycle-to-cycle clock jitter (period jitter) | t _{CLK_CJ} | — | — | 100 | ps | 2 |
| SDn_REF_CLK1_P/SDn_REF_CLK1_N total reference clock jitter, phase jitter (peak-to-peak) | t _{CLK_PJ} | -50 | — | +50 | ps | 2, 3, 4 |

Notes:

- Caution:** Only 100 and 125 MHz have been tested. In-between values do not work correctly with the rest of the system.
- At RefClk input.
- In a frequency band from 150 kHz to 15 MHz at BER of 10⁻¹².
- Total peak-to-peak deterministic jitter must be less than or equal to 50 ps.
- Measurement taken from differential waveform.
- For recommended operating conditions, see [Table 3](#).

3.16.5.2.2 AC transmitter output characteristics

This table provides the differential transmitter output AC characteristics for the SATA interface at Gen 1i/1m or 1.5 Gbits/s transmission. The AC timing specifications do not include RefClk jitter.

Table 86. Gen 1i/1m 1.5 G transmitter AC specifications²

| Parameter | Symbol | Min | Typ | Max | Units | Notes |
|--|-----------------------------|----------|----------|----------|--------|-------|
| Channel speed | t _{CH_SPEED} | — | 1.5 | — | Gbps | — |
| Unit interval | T _{UI} | 666.4333 | 666.6667 | 670.2333 | ps | — |
| Total jitter data-data 5 UI | U _{SATA_TXTJ5UI} | — | — | 0.355 | UI p-p | 1 |
| Total jitter, data-data 250 UI | U _{SATA_TXTJ250UI} | — | — | 0.47 | UI p-p | 1 |
| Deterministic jitter, data-data 5 UI | U _{SATA_TXDJ5UI} | — | — | 0.175 | UI p-p | 1 |
| Deterministic jitter, data-data 250 UI | U _{SATA_TXDJ250UI} | — | — | 0.22 | UI p-p | 1 |

Notes:

- Measured at transmitter output pins peak-to-peak phase variation; random data pattern.
- For recommended operating conditions, see [Table 3](#).

This table provides the differential transmitter output AC characteristics for the SATA interface at Gen 2i/2m or 3.0 Gbits/s transmission. The AC timing specifications do not include RefClk jitter.

Table 87. Gen 2i/2m 3 G transmitter AC specifications²

| Parameter | Symbol | Min | Typ | Max | Units | Notes |
|---|-------------------------|----------|----------|----------|--------|-------|
| Channel speed | t_{CH_SPEED} | — | 3.0 | — | Gbps | — |
| Unit Interval | T_{UI} | 333.2167 | 333.3333 | 335.1167 | ps | — |
| Total jitter $f_{C3dB} = f_{BAUD} \div 500$ | $U_{SATA_TXTJfB/500}$ | — | — | 0.37 | UI p-p | 1 |
| Total jitter $f_{C3dB} = f_{BAUD} \div 1667$ | $U_{SATA_TXTJfB/1667}$ | — | — | 0.55 | UI p-p | 1 |
| Deterministic jitter, $f_{C3dB} = f_{BAUD} \div 500$ | $U_{SATA_TXDJfB/500}$ | — | — | 0.19 | UI p-p | 1 |
| Deterministic jitter, $f_{C3dB} = f_{BAUD} \div 1667$ | $U_{SATA_TXDJfB/1667}$ | — | — | 0.35 | UI p-p | 1 |

Notes:

1. Measured at transmitter output pins peak-to-peak phase variation; random data pattern.
2. For recommended operating conditions, see [Table 3](#).

This table provides the differential transmitter output AC characteristics for the SATA interface at Gen 3i transmission. The AC timing specifications do not include RefClk jitter.

Table 88. Gen 3i transmitter AC specifications

| Parameter | Symbol | Min | Typ | Max | Units |
|---|--------|----------|----------|----------|--------|
| Speed | — | — | 6.0 | — | Gb/s |
| Total jitter before and after compliance interconnect channel | J_T | — | — | 0.52 | UI p-p |
| Random jitter before compliance interconnect channel | J_R | — | — | 0.18 | UI p-p |
| Unit interval | UI | 166.6083 | 166.6667 | 167.5583 | ps |

3.16.5.2.3 AC differential receiver input characteristics

This table provides the Gen1i/1m or 1.5 Gbits/s differential receiver input AC characteristics for the SATA interface. The AC timing specifications do not include RefClk jitter.

Table 89. Gen 1i/1m 1.5 G receiver AC specifications²

| Parameter | Symbol | Min | Typical | Max | Units | Notes |
|--------------------------------|-----------------------|----------|----------|----------|--------|-------|
| Unit Interval | T_{UI} | 666.4333 | 666.6667 | 670.2333 | ps | — |
| Total jitter data-data 5 UI | $U_{SATA_RXTJ5UI}$ | — | — | 0.43 | UI p-p | 1 |
| Total jitter, data-data 250 UI | $U_{SATA_RXTJ250UI}$ | — | — | 0.60 | UI p-p | 1 |

Table continues on the next page...

Electrical characteristics

Table 89. Gen 1i/1m 1.5 G receiver AC specifications² (continued)

| Parameter | Symbol | Min | Typical | Max | Units | Notes |
|--|-----------------------|-----|---------|------|--------|-------|
| Deterministic jitter, data-data 5 UI | $U_{SATA_RXDJ5UI}$ | — | — | 0.25 | UI p-p | 1 |
| Deterministic jitter, data-data 250 UI | $U_{SATA_RXDJ250UI}$ | — | — | 0.35 | UI p-p | 1 |
| Notes: | | | | | | |
| 1. Measured at the receiver. | | | | | | |
| 2. For recommended operating conditions, see Table 3 . | | | | | | |

This table provides the differential receiver input AC characteristics for the SATA interface at Gen2i/2m or 3.0 Gbits/s transmission. The AC timing specifications do not include RefClk jitter.

Table 90. Gen 2i/2m 3 G receiver AC specifications²

| Parameter | Symbol | Min | Typical | Max | Units | Notes |
|--|-------------------------|----------|----------|----------|--------|-------|
| Unit Interval | T_{UI} | 333.2167 | 333.3333 | 335.1167 | ps | — |
| Total jitter $f_{C3dB} = f_{BAUD} \div 500$ | $U_{SATA_RXTJfB/500}$ | — | — | 0.60 | UI p-p | 1 |
| Total jitter $f_{C3dB} = f_{BAUD} \div 1667$ | $U_{SATA_RXTJfB/1667}$ | — | — | 0.65 | UI p-p | 1 |
| Deterministic jitter, $f_{C3dB} = f_{BAUD} \div 500$ | $U_{SATA_RXDJfB/500}$ | — | — | 0.42 | UI p-p | 1 |
| Deterministic jitter, $f_{C3dB} = f_{BAUD} \div 1667$ | $U_{SATA_RXDJfB/1667}$ | — | — | 0.35 | UI p-p | 1 |
| Notes: | | | | | | |
| 1. Measured at the receiver. | | | | | | |
| 2. For recommended operating conditions, see Table 3 . | | | | | | |

This table provides the differential receiver input AC characteristics for the SATA interface at Gen 3i transmission. The AC timing specifications do not include RefClk jitter.

Table 91. Gen 3i receiver AC specifications²

| Parameter | Symbol | Min | Typical | Max | Units | Notes |
|--|--------|----------|----------|----------|--------|-------|
| Total jitter after compliance interconnect channel | J_T | — | — | 0.60 | UI p-p | 1 |
| Random jitter before compliance interconnect channel | J_R | — | — | 0.18 | UI p-p | 1 |
| Unit interval: 6.0 Gb/s | UI | 166.6083 | 166.6667 | 167.5583 | ps | — |
| Notes: | | | | | | |
| 1. Measured at the receiver. | | | | | | |
| 2. The AC specifications do not include RefClk jitter. | | | | | | |

3.16.6 SGMII interface

Each SGMII port features a 4-wire AC-coupled serial link from the SerDes interface of the chip, as shown in [Figure 39](#), where C_{TX} is the external (on board) AC-coupled capacitor. Each SerDes transmitter differential pair features $100\ \Omega$ output impedance. Each input of the SerDes receiver differential pair features $50\ \Omega$ on-die termination to $XGND_n$. The reference circuit of the SerDes transmitter and receiver is shown in [Figure 36](#).

3.16.6.1 SGMII clocking requirements for $SD_n_REF_CLK1_P$ and $SD_n_REF_CLK1_N$

When operating in SGMII mode, the $EC_n_GTX_CLK125$ clock is not required for this port. Instead, a SerDes reference clock is required on $SD1_REF_CLK[1:2]_P$ and $SD1_REF_CLK[1:2]_N$ pins. SerDes lanes may be used for SerDes SGMII configurations based on the RCW Configuration field $SRDS_PRTCL$.

For more information on these specifications, see [SerDes reference clocks](#).

3.16.6.2 SGMII DC electrical characteristics

This section describes the electrical characteristics for the SGMII interface.

3.16.6.2.1 SGMII and SGMII 2.5 G transmit DC specifications

This table describes the SGMII SerDes transmitter AC-coupled DC electrical characteristics. Transmitter DC characteristics are measured at the transmitter outputs ($SD_n_TX_n_P$ and $SD_n_TX_n_N$) as shown in [Figure 40](#).

Table 92. SGMII DC transmitter electrical characteristics ($XV_{DD} = 1.35\text{ V}$)⁴

| Parameter | Symbol | Min | Typ | Max | Unit | Notes |
|--|------------|---------------------|-------|------------------------------|------|--------------------------|
| Output high voltage | V_{OH} | - | - | $1.5 \times V_{OD} _{-max}$ | mV | 1 |
| Output low voltage | V_{OL} | $ V_{OD} _{-min}/2$ | - | - | mV | 1 |
| Output differential voltage ^{2, 3, 5} (XV_{DD-Typ} at 1.35 V) | $ V_{OD} $ | 320 | 500.0 | 725.0 | mV | TECR0[AMP_RE D]=0b000000 |
| | | 293.8 | 459.0 | 665.6 | | TECR0[AMP_RE D]=0b000001 |
| | | 266.9 | 417.0 | 604.7 | | TECR0[AMP_RE D]=0b000011 |
| | | 240.6 | 376.0 | 545.2 | | TECR0[AMP_RE D]=0b000010 |

Table continues on the next page...

Table 92. SGMII DC transmitter electrical characteristics ($V_{DD} = 1.35\text{ V}$)⁴ (continued)

| Parameter | Symbol | Min | Typ | Max | Unit | Notes |
|---------------------------------|--------|-------|-------|-------|----------|-------------------------|
| | | 213.1 | 333.0 | 482.9 | | TECR0[AMP_RED]=0b000110 |
| | | 186.9 | 292.0 | 423.4 | | TECR0[AMP_RED]=0b000111 |
| | | 160.0 | 250.0 | 362.5 | | TECR0[AMP_RED]=0b010000 |
| Output impedance (differential) | R_O | 80 | 100 | 120 | Ω | - |

Notes:

1. This does not align to DC-coupled SGMII.
2. $|V_{OD}| = |V_{SD_TXn_P} - V_{SD_TXn_N}|$. $|V_{OD}|$ is also referred to as output differential peak voltage. $V_{TX-DIFFp-p} = 2 \times |V_{OD}|$.
3. The $|V_{OD}|$ value shown in the Typ column is based on the condition of $XVDD_SRDSn-Typ = 1.35\text{ V}$, no common mode offset variation. SerDes transmitter is terminated with 100- Ω differential load between SDn_TXn_P and SDn_TXn_N .
4. For recommended operating conditions, see [Table 3](#).
5. Example amplitude reduction setting for SGMII on SerDes1 lane E: $SRDS1LN4TECR0[AMP_RED] = 0b000001$ for an output differential voltage of 459 mV typical.

This figure shows an example of a 4-wire AC-coupled SGMII serial link connection.



Figure 39. 4-wire AC-coupled SGMII serial link connection example

This figure shows the SGMII transmitter DC measurement circuit.



Figure 40. SGMII transmitter DC measurement circuit

This table defines the SGMII 2.5G transmitter DC electrical characteristics for 3.125 GBaud.

Table 93. SGMII 2.5G transmitter DC electrical characteristics ($XV_{DD} = 1.35\text{ V}$)¹

| Parameter | Symbol | Min | Typical | Max | Unit | Notes |
|---------------------------------|------------|-----|---------|-----|----------|-------|
| Output differential voltage | $ V_{OD} $ | 400 | - | 600 | mV | - |
| Output impedance (differential) | R_O | 80 | 100 | 120 | Ω | - |

Notes:
 1. For recommended operating conditions, see Table 3.

3.16.6.2.2 SGMII and SGMII 2.5 G DC receiver electrical characteristics

This table lists the SGMII DC receiver electrical characteristics. Source synchronous clocking is not supported. Clock is recovered from the data.

Table 94. SGMII DC receiver electrical characteristics ($SV_{DD} = 0.9\text{ V} / 1.0\text{ V}$)⁴

| Parameter | Symbol | Min | Typ | Max | Unit | Notes | |
|----------------------------|----------------|-------------------|-----|-----|------|-------|------|
| DC input voltage range | - | N/A | | | - | 1 | |
| Input differential voltage | REIDL_TH = 001 | $V_{RX_DIFFp-p}$ | 100 | - | 1200 | mV | 2, 5 |
| | REIDL_TH = 100 | | 175 | - | | | |
| Loss of signal threshold | REIDL_TH = 001 | V_{LOS} | 30 | - | 100 | mV | 3, 5 |
| | REIDL_TH = 100 | | 65 | - | 175 | | |

Table continues on the next page...

Table 94. SGMII DC receiver electrical characteristics ($SV_{DD} = 0.9\text{ V} / 1.0\text{ V}$)⁴ (continued)

| Parameter | Symbol | Min | Typ | Max | Unit | Notes |
|---|----------------|-----|-----|-----|----------|-------|
| Receiver differential input impedance | Z_{RX_DIFF} | 80 | - | 120 | Ω | - |
| Notes: | | | | | | |
| 1. Input must be externally AC coupled. | | | | | | |
| 2. $V_{RX_DIFFp-p}$ is also referred to as peak-to-peak input differential voltage. | | | | | | |
| 3. The concept of this parameter is equivalent to the electrical idle detect threshold parameter in PCI Express. See PCI Express DC physical layer receiver specifications for further explanation. | | | | | | |
| 4. For recommended operating conditions, see Table 3 . | | | | | | |
| 5. The REIDL_TH shown in the table refers to the chip's SRDSxLNmGCR1[REIDL_TH] bit field. | | | | | | |

This table defines the SGMII 2.5G receiver DC electrical characteristics for 3.125 GBaud.

Table 95. SGMII 2.5G receiver DC timing specifications ($SV_{DD} = 0.9\text{ V} / 1.0\text{ V}$)¹

| Parameter | Symbol | Min | Typical | Max | Unit | Notes |
|--|-------------------|-----|---------|------|----------|-------|
| Input differential voltage | $V_{RX_DIFFp-p}$ | 200 | - | 1200 | mV | - |
| Loss of signal threshold | V_{LOS} | 75 | - | 200 | mV | - |
| Receiver differential input impedance | Z_{RX_DIFF} | 80 | - | 120 | Ω | - |
| Note: | | | | | | |
| 1. For recommended operating conditions, see Table 3 . | | | | | | |

3.16.6.3 SGMII AC timing specifications

This section describes the AC timing specifications for the SGMII interface.

3.16.6.3.1 SGMII and SGMII 2.5 G transmit AC timing specifications

This table provides the SGMII and SGMII 2.5 G transmit AC timing specifications. A source synchronous clock is not supported. The AC timing specifications do not include RefClk jitter.

Table 96. SGMII transmit AC timing specifications⁴

| Parameter | Symbol | Min | Typ | Max | Unit | Notes |
|---|----------|---------------|-----|---------------|--------|-------|
| Deterministic jitter | JD | - | - | 0.17 | UI p-p | - |
| Total jitter | JT | - | - | 0.35 | UI p-p | 2 |
| Unit Interval: 1.25 GBaud (SGMII) | UI | 800 - 100 ppm | 800 | 800 + 100 ppm | ps | 1 |
| Unit Interval: 3.125 GBaud (2.5G SGMII) | UI | 320 - 100 ppm | 320 | 320 + 100 ppm | ps | 1 |
| AC coupling capacitor | C_{TX} | 10 | - | 200 | nF | 3 |

Table continues on the next page...

Table 96. SGMII transmit AC timing specifications⁴ (continued)

| Parameter | Symbol | Min | Typ | Max | Unit | Notes |
|--|--------|-----|-----|-----|------|-------|
| Notes: | | | | | | |
| 1. Each UI is 800 ps ± 100 ppm or 320 ps ± 100 ppm. | | | | | | |
| 2. See Figure 42 for single frequency sinusoidal jitter measurements. | | | | | | |
| 3. The external AC coupling capacitor is required. It is recommended that it be placed near the device transmitter output. | | | | | | |
| 4. For recommended operating conditions, see Table 3 . | | | | | | |

3.16.6.3.2 SGMII AC measurement details

Transmitter and receiver AC characteristics are measured at the transmitter outputs (SDn_TXn_P and SDn_TXn_N) or at the receiver inputs (SDn_RXn_P and SDn_RXn_N) respectively, as shown in this figure.



Figure 41. SGMII AC test/measurement load

3.16.6.3.3 SGMII and SGMII 2.5 G receiver AC timing specifications

This table provides the SGMII and SGMII 2.5 G receiver AC timing specifications. The AC timing specifications do not include RefClk jitter. Source synchronous clocking is not supported. Clock is recovered from the data.

Table 97. SGMII receiver AC timing specifications³

| Parameter | Symbol | Min | Typ | Max | Unit | Notes |
|--|-----------------|-----|-----|------|--------|-------|
| Deterministic jitter tolerance | J _D | - | - | 0.37 | UI p-p | 1 |
| Combined deterministic and random jitter tolerance | J _{DR} | - | - | 0.55 | UI p-p | 1 |
| Total jitter tolerance | J _T | - | - | 0.65 | UI p-p | 1, 2 |

Table continues on the next page...

Table 97. SGMII receiver AC timing specifications³ (continued)

| Parameter | Symbol | Min | Typ | Max | Unit | Notes |
|---|--------|---------------|-----|---------------|------|-------|
| Bit error ratio | BER | - | - | 10^{-12} | - | - |
| Unit Interval: 1.25 GBaud (SGMII) | UI | 800 - 100 ppm | 800 | 800 + 100 ppm | ps | 1 |
| Unit Interval: 3.125 GBaud (2.5G SGMII) | UI | 320 - 100 ppm | 320 | 320 + 100 ppm | ps | 1 |

Notes:

1. Measured at receiver.
2. Total jitter is composed of three components: deterministic jitter, random jitter, and single frequency sinusoidal jitter. The sinusoidal jitter may have any amplitude and frequency in the unshaded region of [Figure 1](#). The sinusoidal jitter component is included to ensure margin for low frequency jitter, wander, noise, crosstalk, and other variable system effects.
3. For recommended operating conditions, see [Table 3](#).

The sinusoidal jitter in the total jitter tolerance may have any amplitude and frequency in the unshaded region of this figure.

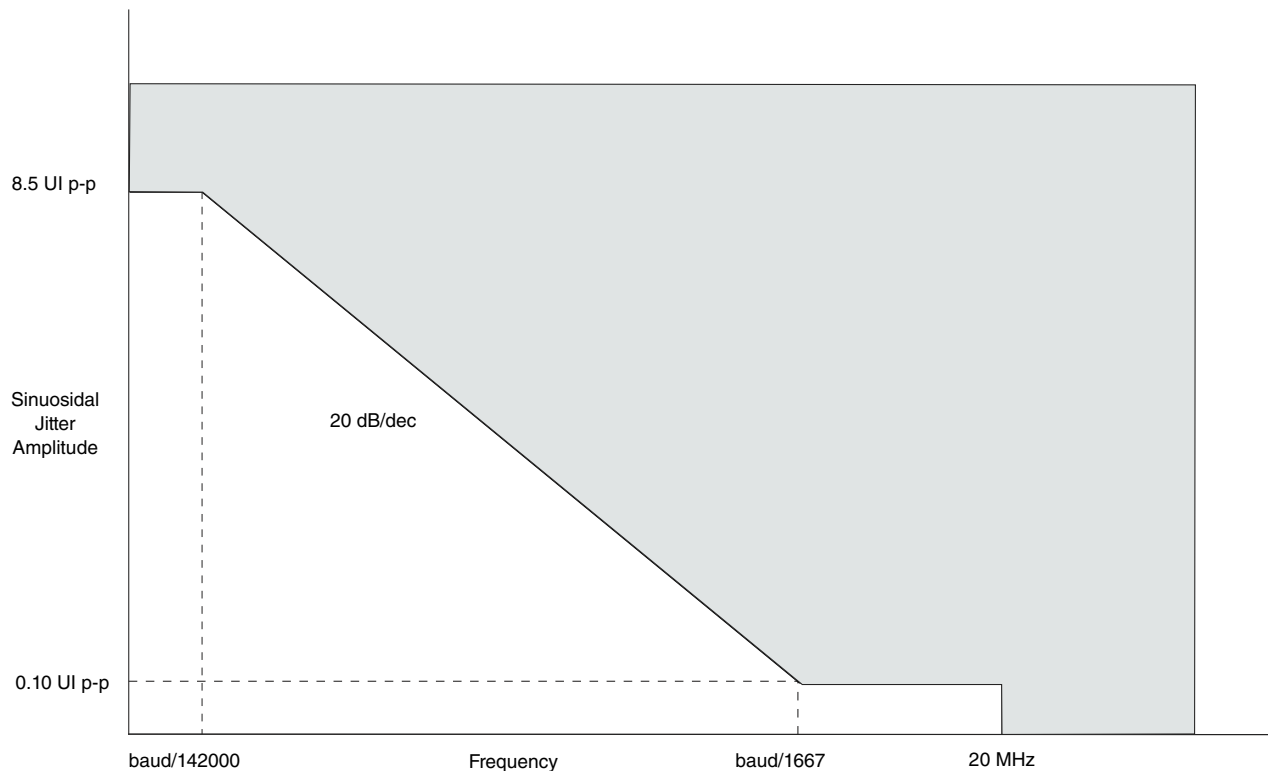
**Figure 42. Single-frequency sinusoidal jitter limits**

3.16.7 Quad serial media-independent interface (QSGMII)

This section describes the clocking as well as the DC and AC electrical characteristics for the QSGMII interface.

3.16.7.1 QSGMII clocking requirements for SDn_REF_CLKn_P and SDn_REF_CLKn_N

For more information on these specifications, see the SerDes reference clocks section of this data sheet.

3.16.7.2 QSGMII DC electrical characteristics

This table describes the QSGMII SerDes transmitter AC-coupled DC electrical characteristics. Transmitter DC characteristics are measured at the transmitter outputs (SDn_TXn_P and SDn_TXn_N).

Table 98. QSGMII transmitter DC electrical characteristics ($V_{DD} = 1.35\text{ V}$)¹

| Parameter | Symbol | Min | Typ | Max | Unit |
|-----------------------------|------------|-------|-------|-------|----------|
| Output differential voltage | V_{DIFF} | 400.0 | - | 900.0 | mV |
| Differential resistance | T_{RD} | 80.0 | 100.0 | 120.0 | Ω |

1. For recommended operating conditions, see [Table 3](#).

This table defines the QSGMII receiver DC electrical characteristics.

Table 99. QSGMII receiver DC timing specifications ($S_{V_{DD}} = 0.9\text{ V} / 1.0\text{ V}$)¹

| Parameter | Symbol | Min | Typ | Max | Unit |
|----------------------------|------------|-------|-------|-------|----------|
| Input differential voltage | V_{DIFF} | 100.0 | - | 900.0 | mV |
| Differential resistance | R_{RDIN} | 80.0 | 100.0 | 120.0 | Ω |

1. For recommended operating conditions, see [Table 3](#).

3.16.7.3 QSGMII AC timing specifications

This table provides the QSGMII transmitter AC timing specifications.

Table 100. QSGMII transmitter AC timing specifications

| Parameter | Symbol | Min | Typ | Max | Unit |
|--------------------------------------|------------|--------------|-----|--------------|--------|
| Transmitter baud rate | T_{BAUD} | 5.000-100ppm | 5.0 | 5.000+100ppm | Gb/s |
| Uncorrelated high probability jitter | T_{UHPJ} | - | - | 0.15 | UI p-p |
| Total jitter tolerance | J_T | - | - | 0.3 | UI p-p |

This table provides the QSGMII receiver AC timing specifications.

Table 101. QSGMII receiver AC timing specifications

| Parameter | Symbol | Min | Typ | Max | Unit | Notes |
|---|---------------------|--------------|-----|--------------|--------|---|
| Receiver baud rate | R_{BAUD} | 5.000-100ppm | 5.0 | 5.000+100ppm | Gb/s | - |
| Uncorrelated bounded high probability jitter | R_{DJ} | - | - | 0.15 | UI p-p | - |
| Correlated bounded high probability jitter | R_{CBHPJ} | - | - | 0.3 | UI p-p | The jitter (R_{CBHPJ}) and amplitude have to be correlated, for example, by a PCB trace. |
| Bounded high probability jitter | R_{BHPJ} | - | - | 0.45 | UI p-p | - |
| Sinusoidal jitter, maximum | $R_{\text{SJ-max}}$ | - | - | 5.0 | UI p-p | - |
| Sinusoidal jitter, high frequency | $R_{\text{SJ-hf}}$ | - | - | 0.05 | UI p-p | - |
| Total jitter (does not include sinusoidal jitter) | R_{TJ} | - | - | 0.6 | UI p-p | - |

The sinusoidal jitter may have any amplitude and frequency in the unshaded region of this figure.

**Figure 43. QSGMII single-frequency sinusoidal jitter limits**

3.16.8 XFI interface

This section describes the DC and AC electrical characteristics for the XFI interface.

3.16.8.1 XFI clocking requirements for SDn_REF_CLKn_P and SDn_REF_CLKn_N

Only SerDes 1 (SD1_REF_CLK[1:2]_P and SD1_REF_CLK[1:2]_N) may be used for SerDes XFI configurations based on the RCW configuration field SRDS_PRTCL.

For more information on these specifications, see the SerDes reference clocks section of this data sheet.

3.16.8.2 XFI DC electrical characteristics

This table defines the XFI transmitter DC electrical characteristics.

Table 102. XFI transmitter DC electrical characteristics ($V_{DD} = 1.35\text{ V}$)¹

| Parameter | Symbol | Min | Typ | Max | Unit |
|---|--------------------------|-------|-------|-------|----------|
| Output differential voltage | $V_{TX-DIFF}$ | 360.0 | - | 770.0 | mV |
| De-emphasized differential output voltage (ratio at 1.14dB) | $V_{TX-DE-RATIO-1.14dB}$ | 0.6 | 1.1 | 1.6 | dB |
| De-emphasized differential output voltage (ratio at 3.5dB) | $V_{TX-DE-RATIO-3.5dB}$ | 3.0 | 3.5 | 4.0 | dB |
| De-emphasized differential output voltage (ratio at 4.66dB) | $V_{TX-DE-RATIO-4.66dB}$ | 4.1 | 4.6 | 5.1 | dB |
| De-emphasized differential output voltage (ratio at 6.0dB) | $V_{TX-DE-RATIO-6.0dB}$ | 5.5 | 6.0 | 6.5 | dB |
| De-emphasized differential output voltage (ratio at 9.5dB) | $V_{TX-DE-RATIO-9.5dB}$ | 9.0 | 9.5 | 10.0 | dB |
| Differential resistance | T_{RD} | 80.0 | 100.0 | 120.0 | Ω |

1. For recommended operating conditions, see [Table 3](#).

This table defines the XFI receiver DC electrical characteristics.

Table 103. XFI receiver DC electrical characteristics ($S_{V_{DD}} = 0.9\text{ V} / 1.0\text{ V}$)¹

| Parameter | Symbol | Min | Typ | Max | Unit | Notes |
|----------------------------|---------------|-------|-------|--------|----------|-------|
| Differential resistance | R_{RD} | 80.0 | 100.0 | 120.0 | Ω | - |
| Input differential voltage | $V_{RX-DIFF}$ | 110.0 | - | 1050.0 | mV | 2 |

1. For recommended operating conditions, see [Table 3](#).

2. Measured at receiver.

3.16.8.3 XFI AC timing specifications

NOTE

The AC specifications do not include RefClk jitter.

This table defines the XFI transmitter AC timing specifications.

Table 104. XFI transmitter AC timing specifications

| Parameter | Symbol | Min | Typ | Max | Unit |
|------------------------|-------------------|----------------|---------|----------------|--------|
| Transmitter baud Rate | T_{BAUD} | 10.3125-100ppm | 10.3125 | 10.3125+100ppm | Gb/s |
| Unit Interval | UI | - | 96.96 | - | ps |
| Deterministic jitter | D_J | - | - | 0.15 | UI p-p |
| Total jitter tolerance | T_J | - | - | 0.3 | UI p-p |

This table defines the XFI receiver AC timing specifications. RefClk jitter is not included.

Table 105. XFI receiver AC timing specifications

| Parameter | Symbol | Min | Typ | Max | Unit | Notes |
|------------------------|----------------------|----------------|---------|----------------|--------|-------|
| Unit Interval | UI | - | 96.96 | - | ps | - |
| Receiver baud rate | R_{BAUD} | 10.3125-100ppm | 10.3125 | 10.3125+100ppm | Gb/s | - |
| Total non-EQJ jitter | $T_{\text{NON-EQJ}}$ | - | - | 0.45 | UI p-p | 1 |
| Total jitter tolerance | T_J | - | - | 0.65 | UI p-p | 1, 2 |

1. The total jitter (TJ) consists of Random Jitter (RJ), Duty Cycle Distortion (DCD), Periodic Jitter (PJ), and Inter-Symbol Interference (ISI). Non-EQJ jitter can include duty cycle distortion (DCD), random jitter (RJ), and periodic jitter (PJ). Non-EQJ jitter is uncorrelated to the primary data stream with exception of the DCD and so cannot be equalized by the receiver under test. It can exhibit a wide spectrum. Non - EQJ = TJ - ISI = RJ + DCD + PJ.

2. The XFI channel has a loss budget of 9.6 dB @5.5GHz. The channel loss including connector @ 5.5GHz is 6dB. The channel crosstalk and reflection margin is 3.6dB. Manual tuning of TX Equalization and amplitude will be required for performance optimization.

This figure shows the sinusoidal jitter tolerance of XFI receiver.



Figure 44. XFI host receiver input sinusoidal jitter tolerance

3.16.9 1000Base-KX interface

This section describes the electrical characteristics for the 1000Base-KX interface. Only AC-coupled operation is supported.

3.16.9.1 1000Base-KX DC electrical characteristics

This table describes the 1000Base-KX SerDes transmitter DC electrical characteristics at TP1 per IEEE Std 802.3ap-2007. Transmitter DC electrical characteristics are measured at the transmitter outputs (SDn_TXn_P and SDn_TXn_N).

Table 106. 1000Base-KX transmitter DC electrical characteristics¹

| Parameter | Symbol | Min | Typ | Max | Unit | Notes |
|-----------------------------|------------------|-------|-----|--------|------|-------|
| Output differential voltage | $V_{TX-DIFFp-p}$ | 800.0 | - | 1600.0 | mV | 2 |

Table continues on the next page...

Table 106. 1000Base-KX transmitter DC electrical characteristics¹ (continued)

| Parameter | Symbol | Min | Typ | Max | Unit | Notes |
|--|----------|------|-------|-------|----------|-------|
| Differential resistance | T_{RD} | 80.0 | 100.0 | 120.0 | Ω | - |
| 1. For recommended operating conditions, see Table 3 . | | | | | | |
| 2. SRDSxLNmTECR0[AMP_RED]=00_0000 | | | | | | |

This table provides the 1000Base-KX receiver DC electrical characteristics.

Table 107. 1000Base-KX receiver DC electrical characteristics¹

| Parameter | Symbol | Min | Max | Unit |
|--|------------------|------|--------|----------|
| Input differential voltage | $V_{RX-DIFFp-p}$ | - | 1600.0 | mV |
| Differential resistance | T_{RDIN} | 80.0 | 120.0 | Ω |
| 1. For recommended operating conditions, see Table 3 . | | | | |

3.16.9.2 1000Base-KX AC timing specifications

NOTE

The AC specifications do not include RefClk jitter.

This table provides the 1000Base-KX transmitter AC timing specifications.

Table 108. 1000Base-KX transmitter AC timing specifications

| Parameter | Symbol | Min | Typ | Max | Unit | Notes |
|--|---------------------|-------------|------|-------------|--------|--|
| Baud rate | T_{BAUD} | 1.25-100ppm | 1.25 | 1.25+100ppm | Gb/s | - |
| Uncorrelated high probability jitter/Random Jitter | T_{UHPJ} / T_{RJ} | - | - | 0.15 | UI p-p | - |
| Deterministic jitter tolerance | T_{DJ} | - | - | 0.1 | UI p-p | - |
| Total jitter tolerance | T_{TJ} | - | - | 0.25 | UI p-p | Total jitter is specified at a BER of 10^{-12} . |

This table provides the 1000Base-KX receiver AC timing specifications, which are based on the parameters defined in IEEE Std 802.3ap-2007.

Table 109. 1000Base-KX receiver AC timing specifications

| Parameter | Symbol | Min | Typ | Max | Unit | Notes |
|-----------|------------|-------------|------|-------------|------|-------|
| Baud rate | R_{BAUD} | 1.25-100ppm | 1.25 | 1.25+100ppm | Gb/s | - |

Table continues on the next page...

Table 109. 1000Base-KX receiver AC timing specifications (continued)

| Parameter | Symbol | Min | Typ | Max | Unit | Notes |
|-----------------------------|--------------|-----|-----|-----------------------------|--------|---|
| Total jitter tolerance | R_{TJ} | - | - | Per IEEE 802.3ap-clause 70. | UI p-p | The receiver interference tolerance level of this parameter shall be measured as described in Annex 69A of the IEEE Std 802.3ap-2007. |
| Random jitter | R_{RJ} | - | - | 0.15 | UI p-p | Random jitter is specified at a BER of 10^{-12} . |
| Sinusoidal jitter (maximum) | R_{SJ-max} | - | - | 0.1 | UI p-p | The receiver interference tolerance level of this parameter shall be measured as described in Annex 69A of the IEEE Std 802.3ap-2007. |

3.16.10 10GBase-KR interface

This section describes the clocking requirements as well as the DC and AC electrical characteristics for the 10GBase-KR interface.

3.16.10.1 10GBase-KR clocking requirements for SDn_REF_CLKn_P and SDn_REF_CLKn_N

Only SerDes 1 (SD1_REF_CLK[1:2]_P and SD1_REF_CLK[1:2]_N) may be used for SerDes 10GBase-KR configurations based on the RCW configuration field SRDS_PRTCL.

For more information on these specifications, see the SerDes reference clocks section of this data sheet.

3.16.10.2 10GBase-KR DC electrical characteristics

This table provides the 10GBase-KR transmitter DC electrical characteristics.

Table 110. 10GBase-KR transmitter DC electrical characteristics ($SV_{DD} = 0.9 / 1.0 V$)¹

| Parameter | Symbol | Min | Typ | Max | Unit |
|---|--------------------------|-------|-------|--------|----------|
| Output differential voltage | $V_{TX-DIFF}$ | 800.0 | - | 1200.0 | mV |
| De-emphasized differential output voltage (ratio at 1.14dB) | $V_{TX-DE-RATIO-1.14dB}$ | 0.6 | 1.1 | 1.6 | dB |
| De-emphasized differential output voltage (ratio at 3.5dB) | $V_{TX-DE-RATIO-3.5dB}$ | 3.0 | 3.5 | 4.0 | dB |
| De-emphasized differential output voltage (ratio at 4.66dB) | $V_{TX-DE-RATIO-4.66dB}$ | 4.1 | 4.6 | 5.1 | dB |
| De-emphasized differential output voltage (ratio at 6.0dB) | $V_{TX-DE-RATIO-6.0dB}$ | 5.5 | 6.0 | 6.5 | dB |
| De-emphasized differential output voltage (ratio at 9.5dB) | $V_{TX-DE-RATIO-9.5dB}$ | 9.0 | 9.5 | 10.0 | dB |
| Differential resistance | T_{RD} | 80.0 | 100.0 | 120.0 | Ω |

1. For recommended operating conditions, see [Table 3](#).

This table provides the 10GBase-KR receiver DC electrical characteristics.

Table 111. 10GBase-KR receiver DC electrical characteristics ($XV_{DD} = 1.35 V$ or $1.5 V$)¹

| Parameter | Symbol | Min | Typ | Max | Unit |
|----------------------------|---------------|------|-----|--------|----------|
| Input differential voltage | $V_{RX-DIFF}$ | - | - | 1200.0 | mV |
| Differential resistance | R_{RD} | 80.0 | - | 120.0 | Ω |

1. For recommended operating conditions, see [Table 3](#).

3.16.10.3 10GBase-KR AC timing specifications

NOTE

The AC specifications do not include RefClk jitter.

This table provides the 10GBase-KR transmitter AC timing specifications.

Table 112. 10GBase-KR transmitter AC timing specifications

| Parameter | Symbol | Min | Typ | Max | Unit |
|--|-------------------|----------------|---------|----------------|--------|
| Transmitter baud rate | T_{BAUD} | 10.3125-100ppm | 10.3125 | 10.3125+100ppm | Gb/s |
| Uncorrelated high probability jitter/ Random Jitter | T_{UHPJ}/T_{RJ} | - | - | 0.15 | UI p-p |
| Deterministic jitter tolerance | T_{DJ} | - | - | 0.15 | UI p-p |
| Total jitter tolerance | T_{TJ} | - | - | 0.3 | UI p-p |

This table provides the 10GBase-KR receiver AC timing specifications.

Table 113. 10GBase-KR receiver AC timing specifications

| Parameter | Symbol | Min | Typ | Max | Unit |
|-----------------------------|---------------------|----------------|---------|---------------------------------------|--------|
| Receiver baud rate | R _{BAUD} | 10.3125-100ppm | 10.3125 | 10.3125+100ppm | Gb/s |
| Total jitter tolerance | R _{TJ} | - | - | Per IEEE Std 802.3ap-2007, Annex 69a. | UI p-p |
| Random jitter | R _{RJ} | - | - | 0.13 | UI p-p |
| Sinusoidal jitter (maximum) | R _{SJ-max} | - | - | 0.115 | UI p-p |
| Duty cycle distortion | D _{CD} | - | - | 0.035 | UI p-p |

3.17 I²C interface

This section describes the DC and AC electrical characteristics for the I²C interface.

3.17.1 I²C DC electrical characteristics

This table provides the DC electrical characteristics for the I²C interface when operating at DV_{DD} = 3.3 V.

Table 114. I²C DC electrical characteristics (DV_{DD} = 3.3 V)¹

| Parameter | Symbol | Min | Max | Unit | Notes |
|---|---------------------|------------------------|------------------------|------|-------|
| Input high voltage | V _{IH} | 0.7 x DV _{DD} | - | V | 2 |
| Input low voltage | V _{IL} | - | 0.2 x DV _{DD} | V | 2 |
| Output low voltage (DV _{DD} = min, IOL = 3 mA, DV _{DD} > 2V) | V _{OL} | - | 0.4 | V | 3 |
| Pulse width of spikes that must be suppressed by the input filter | t _{i2KHKL} | 0.0 | 50.0 | ns | 4 |
| Input current each I/O pin (input voltage is between 0.1 x DV _{DD} (min) and 0.9 x DV _{DD} (max)) | I _I | -50.0 | 50.0 | μA | 5 |
| Capacitance for each I/O pin | C _I | - | 10.0 | pF | - |

1. For recommended operating conditions, see [Table 3](#).
2. The min V_{IL} and max V_{IH} values are based on the respective min and max DV_{IN} values found in [Table 3](#).
3. The output voltage (open drain or open collector) condition = 3 mA sink current.
4. See the chip reference manual for information about the digital filter used.
5. I/O pins obstruct the SDA and SCL lines if DV_{DD} is switched off.

This table provides the DC electrical characteristics for the I²C interface operating at $DV_{DD} = 1.8\text{ V}$.

Table 115. I²C DC electrical characteristics ($DV_{DD} = 1.8\text{ V}$)¹

| Parameter | Symbol | Min | Max | Unit | Notes |
|---|--------------|----------------------|----------------------|---------------|-------|
| Input high voltage | V_{IH} | $0.7 \times DV_{DD}$ | - | V | 2 |
| Input low voltage | V_{IL} | - | $0.3 \times DV_{DD}$ | V | 2 |
| Output low voltage ($DV_{DD} = \text{min}$, $I_{OL} = 3\text{ mA}$, $DV_{DD} \leq 2\text{V}$) | V_{OL} | 0.0 | 0.36 | V | 3 |
| Pulse width of spikes that must be suppressed by the input filter | t_{I2KHKL} | 0.0 | 50.0 | ns | 4 |
| Input current each I/O pin (input voltage is between $0.1 \times DV_{DD}$ (min) and $0.9 \times DV_{DD}$ (max)) | I_I | -50.0 | 50.0 | μA | 5 |
| Capacitance for each I/O pin | C_I | - | 10.0 | pF | - |

1. For recommended operating conditions, see [Table 3](#).
2. The min V_{IL} and max V_{IH} values are based on the respective min and max DV_{IN} values found in [Table 3](#).
3. The output voltage (open drain or open collector) condition = 3 mA sink current.
4. See the chip reference manual for information about the digital filter used.
5. I/O pins obstruct the SDA and SCL lines if DV_{DD} is switched off.

3.17.2 I²C AC timing specifications

This table provides the AC timing specifications for the I²C interface.

Table 116. I²C AC timing specifications¹

| Parameter | Symbol | Min | Max | Unit | Notes |
|--|--------------|-------|-------|---------------|--|
| SCL clock frequency | f_{I2C} | 0.0 | 400.0 | kHz | - |
| Low period of the SCL clock | t_{I2CL} | 1.3 | - | μs | - |
| High period of the SCL clock | t_{I2CH} | 0.6 | - | μs | - |
| Setup time for a repeated START condition | t_{I2SVKH} | 0.6 | - | μs | - |
| Hold time (repeated) START condition (after this period, the first clock pulse is generated) | t_{I2SXKL} | 0.6 | - | μs | - |
| Data setup time | t_{I2DVKH} | 100.0 | - | ns | - |
| Data input hold time (CBUS compatible masters, I ² C bus devices) | t_{I2DXKL} | 0.0 | - | μs | As a transmitter, the chip provides a delay time of at least 300 ns for the SDA signal (referred to the $V_{IH\text{min}}$ of the SCL signal) to bridge the undefined region of the falling edge of SCL to avoid unintended generation |

Table continues on the next page...

Table 116. I²C AC timing specifications¹ (continued)

| Parameter | Symbol | Min | Max | Unit | Notes |
|---|---------------------|------------|-------|------|--|
| | | | | | of a START or STOP condition. When the chip acts as the I ² C bus master while transmitting, it drives both SCL and SDA. As long as the load on SCL and SDA are balanced, the chip does not generate an unintended START or STOP condition. Therefore, the 300 ns SDA output delay time is not a concern. |
| Data output delay time | t _{I2OVKL} | - | 0.9 | μs | The maximum t _{I2OVKL} has to be met only if the device does not stretch the LOW period (t _{I2CL}) of the SCL signal. |
| Setup time for STOP condition | t _{I2PVKH} | 0.6 | - | μs | - |
| Bus free time between a STOP and START condition | t _{I2KHDX} | 1.3 | - | μs | - |
| Noise margin at the LOW level for each connected device (including hysteresis) | V _{NL} | 0.1 x DVDD | - | V | - |
| Noise margin at the HIGH level for each connected device (including hysteresis) | V _{NH} | 0.2 x DVDD | - | V | - |
| Capacitive load for each bus line | C _b | - | 400.0 | pF | - |

1. The symbols used for timing specifications herein follow these patterns: t_{(first two letters of functional block)(signal)(state)(reference)(state)} for inputs and t_{(first two letters of functional block)(reference)(state)(signal)(state)} for outputs. For example, t_{I2DVKH} symbolizes I²C timing (I2) with respect to the time data input signals (D) reaching the valid state (V) relative to the tI²C clock reference (K) going to the high (H) state or setup time. Also, t_{I2SXKL} symbolizes I²C timing (I2) for the time that the data with respect to the START condition (S) went invalid (X) relative to the tI²C clock reference (K) going to the low (L) state or hold time. Also, tI_{2PVKH} symbolizes I²C timing (I2) for the time that the data with respect to the STOP condition (P) reaches the valid state (V) relative to the tI²C clock reference (K) going to the high (H) state or setup time.

This figure shows the AC test load for the I²C interface.

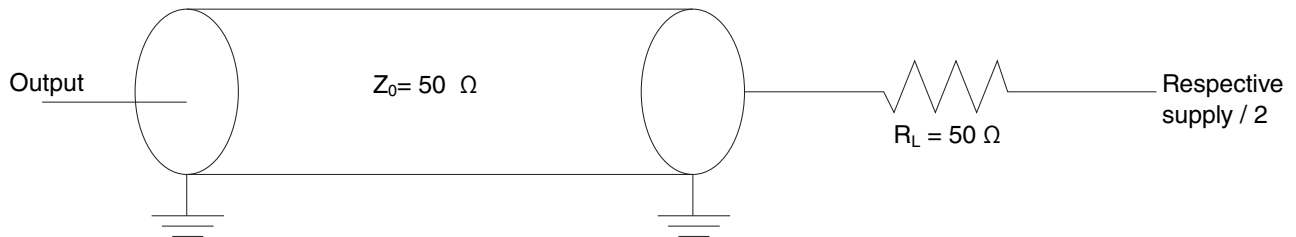

Figure 45. I²C AC test load

This figure shows the AC timing diagram for the I²C interface.

Figure 46. I²C bus AC timing diagram

3.18 Integrated Flash Controller

This section describes the DC and AC electrical specifications for the integrated flash controller.

3.18.1 Integrated Flash Controller DC electrical characteristics

Table below provides the DC electrical characteristics for the integrated flash controller when operating at $OV_{DD} = 1.8\text{ V}$.

Table 117. Integrated Flash Controller DC electrical characteristics (1.8 V)³

| Parameter | Symbol | Min | Max | Unit | Note |
|---|----------|----------------------|----------------------|---------------|------|
| Input high voltage | V_{IH} | $0.7 \times OV_{DD}$ | - | V | 1 |
| Input low voltage | V_{IL} | - | $0.3 \times OV_{DD}$ | V | 1 |
| Input current ($V_{IN} = 0\text{ V}$ or $V_{IN} = OV_{DD}$) | I_{IN} | - | ± 50 | μA | 2 |
| Output high voltage ($OV_{DD} = \text{min}$, $I_{OH} = -0.5\text{ mA}$) | V_{OH} | 1.6 | - | V | - |
| Output low voltage ($OV_{DD} = \text{min}$, $I_{OL} = 0.5\text{ mA}$) | V_{OL} | - | 0.32 | V | - |

NOTE:

1. The min V_{IL} and max V_{IH} values are based on the respective min and max OV_{IN} values found in [Table 3](#).
2. The symbol V_{IN} , in this case, represents the OV_{IN} symbol referenced in [Table 3](#).
3. For recommended operating conditions, see [Table 3](#).

3.18.2 Integrated Flash Controller AC timing specifications

This section describes the AC timing specifications for the integrated flash controller.

3.18.2.1 Test condition

The figure below provides the AC test load for the integrated flash controller.

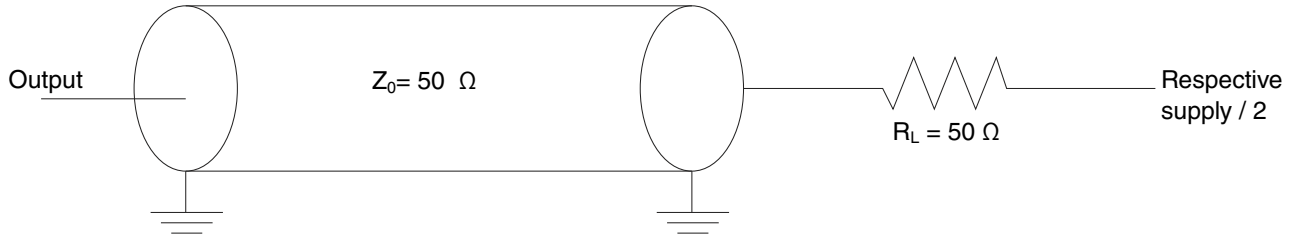

Figure 47. Integrated Flash Controller AC test load

3.18.2.2 IFC AC timing specifications (GPCM/GASIC)

The table below describes the input AC timing specifications for the IFC-GPCM and IFC-GASIC interface.

Table 118. Integrated flash controller input timing specifications for GPCM and GASIC mode ($OV_{DD} = 1.8 V$)¹

| Parameter | Symbol | Min | Max | Unit | Notes |
|-------------|---------------|-----|-----|------|-------|
| Input setup | $t_{IBIVKH1}$ | 4 | - | ns | - |
| Input hold | $t_{IBIXKH1}$ | 1 | - | ns | - |

NOTE:
1. For recommended operating conditions, see [Table 3](#).

The figure below shows the input AC timing diagram for the IFC-GPCM, IFC-GASIC interface.

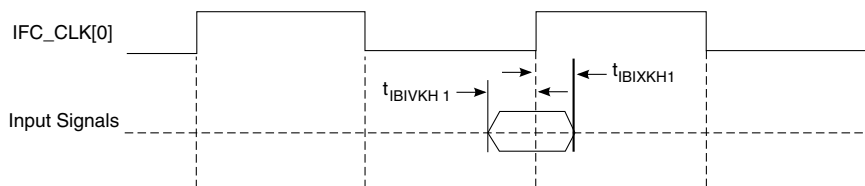

Figure 48. IFC-GPCM, IFC-GASIC input AC timing specifications

The table below describes the output AC timing specifications for the IFC-GPCM and IFC-GASIC interfaces.

Table 119. Integrated flash controller IFC-GPCM and IFC-GASIC interface output timing specifications ($OV_{DD} = 1.8 V$)²

| Parameter | Symbol | Min | Max | Unit | Notes |
|-------------------------------|----------------------|-----|----------|------|-------|
| IFC_CLK cycle time | t_{IBK} | 10 | - | ns | - |
| IFC_CLK duty cycle | t_{IBKH} / t_{IBK} | 45 | 55 | % | - |
| Output delay | $t_{IBKLOV1}$ | - | 1.5 | ns | - |
| Output hold | t_{IBKLOX} | - | -2 | ns | 1 |
| IFC_CLK[0] to IFC_CLK[m] skew | $t_{IBKSKEW}$ | 0 | ± 75 | ps | - |

NOTE:

- The output hold is negative. This means that output transition happens earlier than the falling edge of IFC_CLK.
- For recommended operating conditions, see [Table 3](#).

The figure below shows the output AC timing diagram for the IFC-GPCM, IFC-GASIC interface.

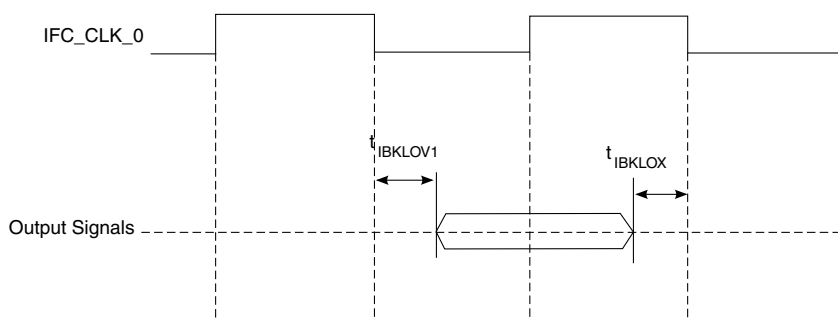

Figure 49. IFC-GPCM, IFC-GASIC signals

3.18.2.3 IFC AC timing specifications (NOR)

The table below describes the input timing specifications for the IFC-NOR interface.

Table 120. Integrated flash controller input timing specifications for NOR mode ($OV_{DD} = 1.8 V$)²

| Parameter | Symbol | Min | Max | Unit | Notes |
|-------------|---------------|------------------------------|-----|------|-------|
| Input setup | $t_{IBIVKH2}$ | $(2 \times t_{IP_CLK}) + 2$ | - | ns | 1 |
| Input hold | $t_{IBIXKH2}$ | $(1 \times t_{IP_CLK}) + 1$ | - | ns | 1 |

Notes:

- t_{IP_CLK} is the period of ip clock (not the IFC_CLK) on which IFC is running.
- For recommended operating conditions, see [Table 3](#).

The figure below shows the AC input timing diagram for input signals for the IFC-NOR interface. Here TRAD is a programmable delay parameter. See the IFC section of the chip reference manual for more information.



Figure 50. IFC-NOR interface input AC timings

The table below describes the output AC timing specifications of IFC-NOR interface.

Table 121. Integrated flash controller IFC-NOR interface output timing specifications ($OV_{DD} = 1.8\text{ V}$)²

| Parameter | Symbol | Min | Max | Unit | Notes |
|--|--------------|-----|-----------|------|-------|
| Output delay | t_{BKLOV2} | - | ± 1.5 | ns | 1 |
| NOTE: | | | | | |
| 1. This effectively means that a signal change may appear anywhere within $\pm t_{BKLOV2}$ (max) duration, from the point where it's expected to change. | | | | | |
| 2. For recommended operating conditions, see Table 3 . | | | | | |

The figure below shows the AC timing diagram for IFC-NOR interface output signals. The timing specs have been illustrated here by taking timings between two signals, CS_B and OE_B as an example. In a read operation, OE_B is supposed to change the TACO (a programmable delay; see the IFC section of the chip reference manual for more information) time after CS_B. Because of the skew between the signals, OE_B may change anywhere within the window of time defined by t_{BKLOV2} . This concept applies to other IFC-NOR interface output signals as well. The diagram is an example that shows the skew between any two chronological toggling signals as per the protocol. The list of IFC-NOR output signals is as follows: NRALE, NRAVD_B, NRWE_B, NROE_B, CS_B, AD (Address phase).



Figure 51. IFC-NOR interface output AC timings

3.18.2.4 IFC AC timing specifications (NAND)

The table below describes the input timing specifications of the IFC-NAND interface.

Table 122. Integrated flash controller input timing specifications for NAND mode ($OV_{DD} = 1.8\text{ V}$)²

| Parameter | Symbol | Min | Max | Unit | Notes |
|----------------------|--------------|------------------------------|-----|---------------|-------|
| Input setup | t_{BIVKH3} | $(2 \times t_{IP_CLK}) + 2$ | - | ns | 1 |
| Input hold | t_{BIXKH3} | 1 | - | ns | 1 |
| IFC_RB_B pulse width | t_{IBCH} | 2 | - | t_{IP_CLK} | 1 |

NOTE:

- t_{IP_CLK} is the period of ip clock on which IFC is running.
- For recommended operating conditions, see [Table 3](#).

The figure below shows the AC input timing diagram for input signals of IFC-NAND interface. Here TRAD is a programmable delay parameter. See the IFC section of the chip reference manual for more information.

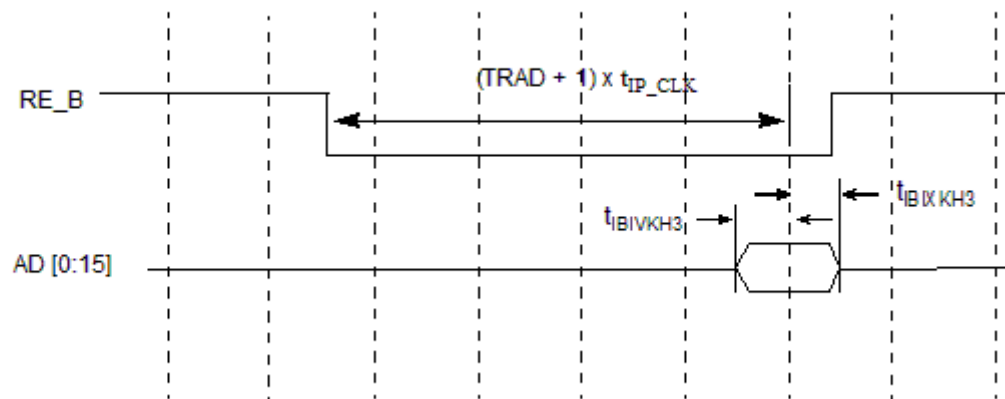

Figure 52. IFC-NAND interface input AC timings

NOTE

t_{IP_CLK} is the period of ip clock (not the IFC_CLK) on which IFC is running.

The table below describes the output AC timing specifications for the IFC-NAND interface.

Table 123. Integrated flash controller IFC-NAND interface output timing specifications ($OV_{DD} = 1.8\text{ V}$)²

| Parameter | Symbol | Min | Max | Unit | Notes |
|--|---------------|-----|-----------|------|-------|
| Output delay | $t_{IBKLOV3}$ | - | ± 1.5 | ns | 1 |
| NOTE: | | | | | |
| 1. This effectively means that a signal change may appear anywhere within $t_{IBKLOV3}$ (min) to $t_{IBKLOV3}$ (max) duration, from the point where it's expected to change. | | | | | |
| 2. For recommended operating conditions, see Table 3 . | | | | | |

The figure below shows the AC timing diagram for output signals of IFC-NAND interface. The timing specs are shown here by taking the timings between two signals, CS_B and CLE as an example. CLE is supposed to change TCCST (a programmable delay; see the IFC section of the chip reference manual for more information) time after CS_B. Because of the skew between the signals, CLE may change anywhere within window of time defined by $t_{IBKLOV3}$. This concept applies to other output signals of the IFC-NAND interface as well. The diagram is an example to show the skew between any two chronological toggling signals as per the protocol. The list of output signals is as follows: NDWE_B, NDRE_B, NDALE, WP_B, NDCLE, CS_B, AD.



Figure 53. IFC-NAND interface output AC timings

3.18.2.5 IFC-NAND SDR AC timing specifications

This table describes the AC timing specifications for the IFC-NAND SDR interface. These specifications are compliant to the SDR mode of the ONFI specification revision 3.0.

Table 124. Integrated flash controller IFC-NAND SDR interface AC timing specifications (OVDD = 1.8 V)

| Parameter | Symbol | I/O | Min | Max | Unit | Notes |
|---|------------|-----|-----------------------|-----------------------|---------------|-----------|
| Address cycle to data loading time | t_{ADL} | O | TADLE - 1500(ps) | TADLE + 1500(ps) | t_{IP_CLK} | Figure 54 |
| ALE hold time | t_{ALH} | O | TWCHT - 1500(ps) | TWCHT + 1500(ps) | t_{IP_CLK} | Figure 55 |
| ALE setup time | t_{ALS} | O | TWP - 1500(ps) | TWP + 1500(ps) | t_{IP_CLK} | Figure 55 |
| ALE to RE_n delay | t_{AR} | O | TWHRE - 1500(ps) | TWHRE + 1500(ps) | t_{IP_CLK} | Figure 56 |
| CE_n hold time | t_{CH} | O | 5 + 1500(ps) | - | ns | Figure 55 |
| CE_n high to input hi-Z | t_{CHZ} | I | TRHZ - 1500(ps) | TRHZ + 1500(ps) | t_{IP_CLK} | Figure 57 |
| CLE hold time | t_{CLH} | O | TWCHT - 1500(ps) | TWCHT + 1500(ps) | t_{IP_CLK} | Figure 55 |
| CLE to RE_n delay | t_{CLR} | O | TWHRE - 1500(ps) | TWHRE - 1500(ps) | t_{IP_CLK} | Figure 58 |
| CLE setup time | t_{CLS} | O | TWP - 1500(ps) | TWP + 1500(ps) | t_{IP_CLK} | Figure 55 |
| CE_n high to input hold | t_{COH} | I | 150 - 1500(ps) | - | ns | Figure 57 |
| CE_n setup time | t_{CS} | O | TCS - 1500(ps) | TCS + 1500(ps) | t_{IP_CLK} | Figure 55 |
| Data hold time | t_{DH} | O | TWCHT - 1500(ps) | TWCHT + 1500(ps) | t_{IP_CLK} | Figure 55 |
| Data setup time | t_{DS} | O | TWP - 1500(ps) | TWP + 1500(ps) | t_{IP_CLK} | Figure 55 |
| Busy time for Set Features and Get Features | t_{FEAT} | O | - | FTOCNT | t_{IP_CLK} | Figure 59 |
| Output hi-Z to RE_n low | t_{IR} | O | TWHRE - 1500(ps) | TWHRE + 1500(ps) | t_{IP_CLK} | Figure 60 |
| Interface and Timing Mode Change time | t_{ITC} | O | - | FTOCNT | t_{IP_CLK} | Figure 59 |
| RE_n cycle time | t_{RC} | O | TRP + TREH - 1500(ps) | TRP + TREH + 1500(ps) | t_{IP_CLK} | Figure 57 |
| RE_n access time | t_{REA} | I | - | (TRAD - 1) + 2(ns) | t_{IP_CLK} | Figure 57 |
| RE_n high hold time | t_{REH} | I | TREH | TREH | t_{IP_CLK} | Figure 57 |
| RE_n high to input hold | t_{RHOH} | I | 0 | - | ns | Figure 57 |
| RE_n high to WE_n low | t_{RHW} | O | 100 + 1500(ps) | - | ns | Figure 61 |
| RE_n high to input hi-Z | t_{RHZ} | I | TRHZ - 1500(ps) | TRHZ + 1500(ps) | t_{IP_CLK} | Figure 57 |
| RE_n low to input data hold | t_{RLOH} | I | 0 | - | ns | Figure 62 |
| RE_n pulse width | t_{RP} | O | TRP | TRP | t_{IP_CLK} | Figure 57 |
| Ready to data input cycle (data only) | t_{RR} | O | TRR - 1500(ps) | TRR + 1500(ps) | t_{IP_CLK} | Figure 57 |

Table continues on the next page...

Table 124. Integrated flash controller IFC-NAND SDR interface AC timing specifications (OVDD = 1.8 V) (continued)

| Parameter | Symbol | I/O | Min | Max | Unit | Notes |
|---|----------------------|-----|------------------------|------------------------|---------------|-----------|
| Device reset time, measured from the falling edge of R/B_n to the rising edge of R/B_n. | t_{RST} (raw NAND) | O | - | FTOCNT | t_{IP_CLK} | Figure 63 |
| Device reset time, measured from the falling edge of R/B_n to the rising edge of R/B_n. | t_{RST2} (EZ NAND) | O | - | FTOCNT | t_{IP_CLK} | Figure 63 |
| (WE_n high or CLK rising edge) to SR[6] low | t_{WB} | O | TWBE + TWH - 1500(ps) | TWBE + TWH + 1500(ps) | t_{IP_CLK} | Figure 55 |
| WE_n cycle time | t_{WC} | O | TWP + TWH | TWP + TWH | t_{IP_CLK} | Figure 64 |
| WE_n high hold time | t_{WH} | O | TWH | TWH | t_{IP_CLK} | Figure 64 |
| Command, address, or data input cycle to data output cycle | t_{WHR} | O | TWHRE + TWH - 1500(ps) | TWHRE + TWH + 1500(ps) | t_{IP_CLK} | Figure 65 |
| WE_n pulse width | t_{WP} | O | TWP | TWP | t_{IP_CLK} | Figure 55 |
| WP_n transition to command cycle | t_{WW} | O | TWW - 1500(ps) | TWW + 1500(ps) | t_{IP_CLK} | Figure 66 |
| Data Input hold | $t_{IBIXKH4}$ | I | 1 | - | t_{IP_CLK} | Figure 67 |

NOTE:

1. t_{IP_CLK} is the clock period of the IP clock (on which the IFC IP is running). Note that that the IFC IP clock does not come out of the device.

This figure shows the t_{ADL} timing.

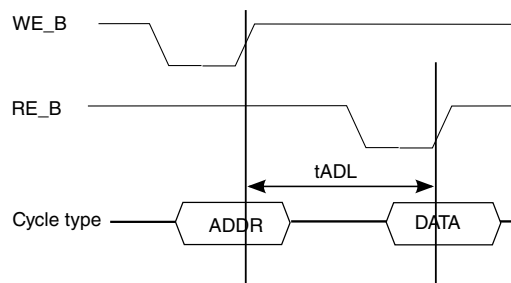

Figure 54. t_{ADL} timing

This figure shows the command cycle.



Figure 55. Command cycle

This figure shows the t_{AR} timings.

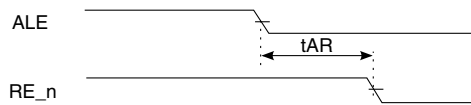

Figure 56. t_{AR} timings

This figure shows the data input cycle timings.

Electrical characteristics



Figure 57. Data input cycle timings

This figure shows the t_{CLR} timings.



Figure 58. t_{CLR} timings

This figure shows the t_{WB} , t_{FEAT} , t_{ITC} , and t_{RR} timings.



Figure 59. t_{WB} , t_{FEAT} , t_{ITC} , and t_{RR} timings

This figure shows the read status timings.

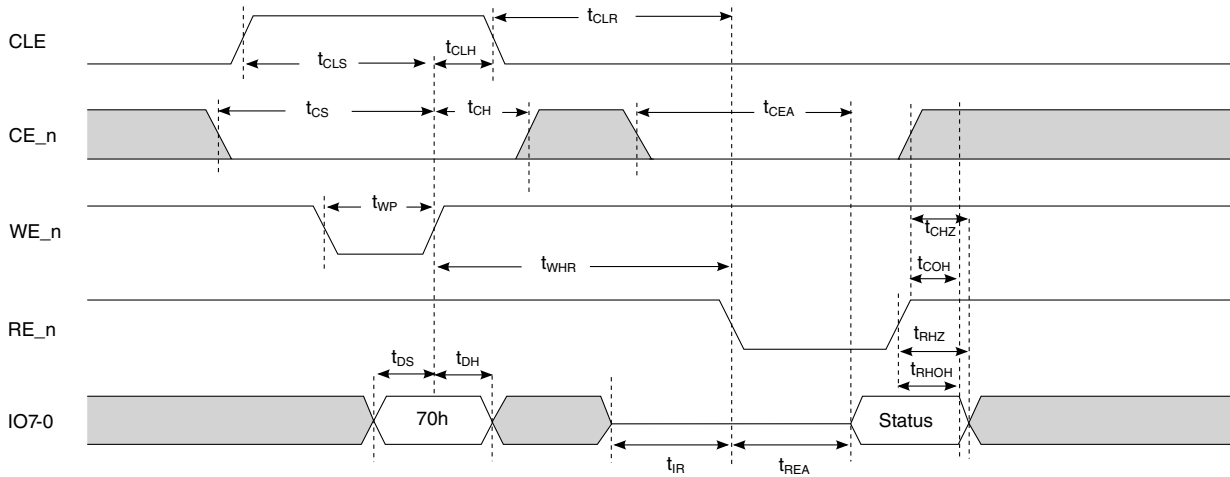

Figure 60. Read status timings

This figure shows the t_{RHW} timings.



Figure 61. t_{RHW} timings

This figure shows the EDO mode data input cycle timings.

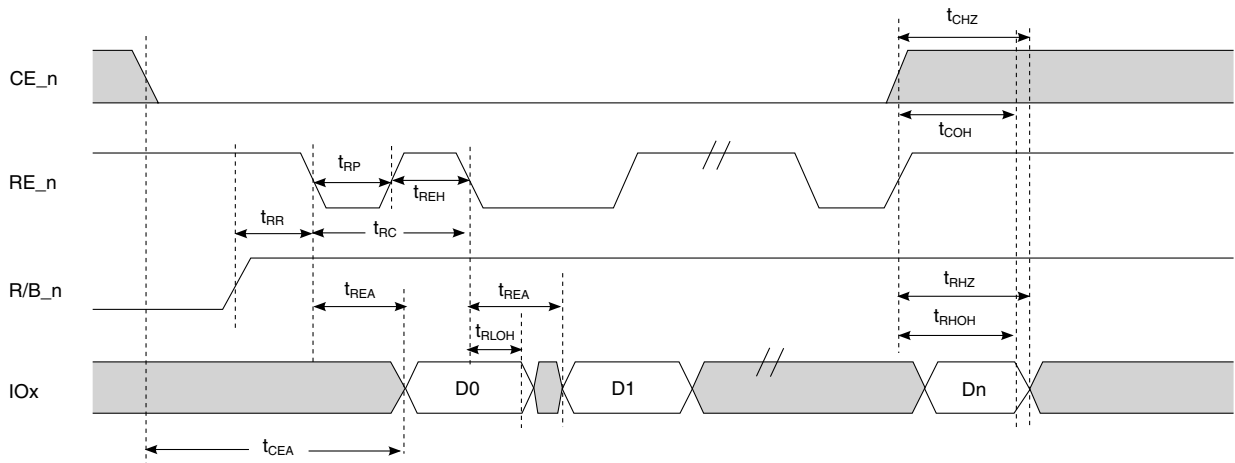

Figure 62. EDO mode data input cycle timings

This figure shows the t_{WB} and t_{RST} timings.



Figure 63. t_{WB} and t_{RST} timings

This figure shows the address latch timings.



Figure 64. Address latch timings

This figure shows the t_{WHR} timings.



Figure 65. t_{WHR} timings

This figure shows the t_{WW} timings.



Figure 66. t_{WW} timings

This figure shows the $t_{IBIXKH4}$ timings.

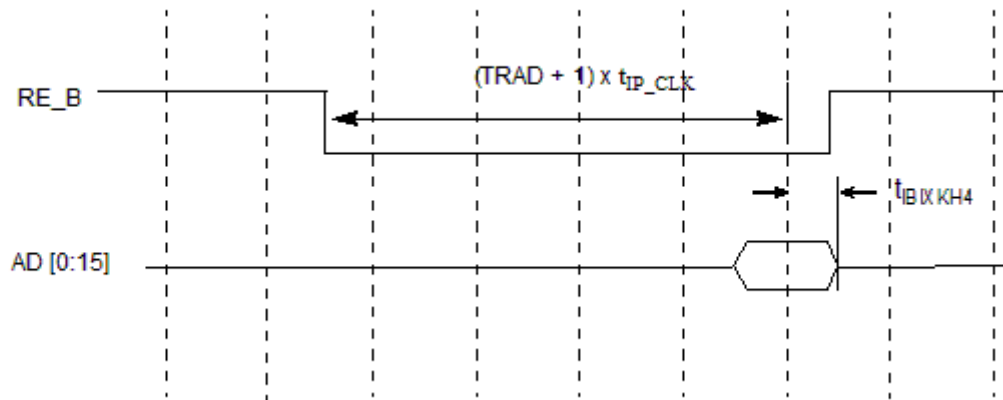

Figure 67. $t_{IBIXKH4}$ timings

3.18.2.6 IFC-NAND NVDDR AC timing specification

The table below describes the AC timing specifications for the IFC-NAND NVDDR interface. These specifications are compliant to NVDDR mode of ONFI specification revision 3.0.

Table 125. Integrated flash controller IFC-NAND NVDDR interface AC timing specifications (OVDD = 1.8 V)

| Parameter | Symbol | I/O | Min | Max | Unit | Notes |
|------------------------------------|-----------|-----|--------------|---------------|---------------|-----------|
| Access window of DQ[7:0] from CLK | t_{AC} | I | 3 - 150 (ps) | 20 + 150 (ps) | ns | Figure 71 |
| Address cycle to data loading time | t_{ADL} | I | TADL | - | t_{IP_CLK} | Figure 72 |

Table continues on the next page...

Table 125. Integrated flash controller IFC-NAND NVDDR interface AC timing specifications (OVDD = 1.8 V) (continued)

| Parameter | Symbol | I/O | Min | Max | Unit | Notes |
|---|---|-----|--|--|---------------------|-----------|
| Command, Address, Data delay (command to command, address to address, command to address, address to command, command/address to start of data) Fast | tCADf | O | TCAD - 150 (ps) | TCAD + 150 (ps) | t _{IP_CLK} | Figure 68 |
| Command, Address, Data delay (command to command, address to address, command to address, address to command, command/address to start of data) slow | tCADs | O | TCAD - 150 (ps) | TCAD + 150 (ps) | t _{IP_CLK} | Figure 68 |
| Command/address DQ hold time | t _{CAH} | O | 2 + 150 (ps) | - | ns | Figure 68 |
| CLE and ALE hold time | t _{CALH} | O | 2 + 150 (ps) | - | ns | Figure 68 |
| CLE and ALE setup time | t _{CALS} | O | 2 + 150 (ps) | - | ns | Figure 68 |
| Command/address DQ setup time | t _{CAS} | O | 2 + 150 (ps) | - | ns | Figure 68 |
| CE# hold time | t _{CH} | O | 2 + 150 (ps) | - | ns | Figure 68 |
| Average clock cycle time, also known as tCK | t _{CK(avg)} or t _{CK} | O | 10 | - | ns | Figure 68 |
| Absolute clock period, measured from rising edge to the next consecutive rising edge | t _{CK(abs)} | O | t _{CK(avg)} + t _{JIT(per)} min | t _{CK(avg)} + t _{JIT(per)} max | ns | Figure 68 |
| Clock cycle high | t _{CKH(abs)} | O | 0.45 | 0.55 | tCK | Figure 68 |
| Clock cycle low | t _{CKL(abs)} | O | 0.45 | 0.55 | tCK | Figure 68 |
| Data input end to W/R# high B16 | t _{CKWR} | O | TCKWR - 150 (ps) | TCKWR + 150 (ps) | t _{IP_CLK} | Figure 71 |
| CE# setup time | t _{CS} | O | TCS - 150 (ps) | TCS + 150 (ps) | t _{IP_CLK} | Figure 70 |
| Data DQ hold time | t _{DH} | O | 1050 | - | ps | Figure 70 |
| Access window of DQS from CLK | t _{DQSCK} | I | - | 20 + 150 (ps) | ns | Figure 71 |
| W/R# low to DQS/DQ driven by device | t _{DQSD} | I | -150 (ps) | 18 + 150 (ps) | ns | Figure 71 |
| DQS output high pulse width | t _{DQSH} | O | 0.45 | 0.55 | tCK | Figure 70 |
| W/R# high to DQS/DQ tri-state by device | t _{DQSHZ} | O | RHZ - 150 (ps) | RHZ + 150 (ps) | t _{IP_CLK} | Figure 68 |
| DQS output low pulse width | t _{DQSL} | O | 0.45 | 0.55 | tCK | Figure 70 |

Table continues on the next page...

Table 125. Integrated flash controller IFC-NAND NVDDR interface AC timing specifications (OVDD = 1.8 V) (continued)

| Parameter | Symbol | I/O | Min | Max | Unit | Notes |
|---|-----------------------------|-----|---|------------------|---------------------|-----------|
| DQS-DQ skew, DQS to last DQ valid, per access | t _{DQSQ} | I | - | 1000 | ps | Figure 71 |
| Data output to first DQS latching transition | t _{DQSS} | O | 0.75 + 150 (ps) | 1.25 - 150 (ps) | tCK | Figure 70 |
| Data DQ setup time | t _{DS} | O | 1050 | - | ps | Figure 70 |
| DQS falling edge to CLK rising - hold time | t _{DSH} | O | 0.2 + 150 (ps) | - | tCK | Figure 70 |
| DQS falling edge to CLK rising - setup time | t _{DSS} | O | 0.2 + 150 (ps) | - | tCK | Figure 70 |
| Input data valid window | t _{DVW} | I | t _{DVW} = t _{QH} - t _{DQSQ} | - | ns | Figure 71 |
| Busy time for Set Features and Get Features | t _{FEAT} | I | - | FTOCNT | t _{IP_CLK} | Figure 73 |
| Half-clock period | t _{HP} | O | t _{HP} = min(t _{CKL} , t _{CKH}) | - | ns | Figure 71 |
| Interface and Timing Mode Change time | t _{ITC} | I | - | FTOCNT | t _{IP_CLK} | Figure 73 |
| The deviation of a given tCK(abs) from tCK(avg) | t _{JIT(per)} | O | -0.5 | 0.5 | ns | NA |
| DQ-DQS hold, DQS to first DQ to go non-valid, per access | t _{QH} | I | t _{QH} = t _{HP} - t _{QHS} | - | t _{IP_CLK} | Figure 71 |
| Data hold skew factor | t _{QHS} | I | - | 1+150 (ps) | - | - |
| Data input cycle to command, address, or data output cycle | t _{RHW} | O | TRHW | - | t _{IP_CLK} | Figure 74 |
| Ready to data input cycle (data only) | t _{RR} | I | TRR | - | t _{IP_CLK} | Figure 73 |
| Device reset time, measured from the falling edge of R/B# to the rising edge of R/B#. | t _{RST} (raw NAND) | O | FTOCNT | FTOCNT | t _{IP_CLK} | Figure 75 |
| Device reset time, measured from the falling edge of R/B# to the rising edge of R/B#. | t _{RST2} (EZ NAND) | O | FTOCNT | FTOCNT | t _{IP_CLK} | Figure 75 |
| CLK rising edge to SR[6] low | t _{WB} | O | TWB - 150 (ps) | TWB + 150 (ps) | t _{IP_CLK} | Figure 75 |
| Command, address or data output cycle to data input cycle | t _{WHR} | O | TWHR | - | t _{IP_CLK} | Figure 76 |
| DQS write preamble | t _{WPRE} | O | 1.5 | - | tCK | Figure 70 |
| DQS write postamble | t _{WPST} | O | 1.5 | - | tCK | Figure 70 |
| W/R# low to data input cycle | t _{WRCK} | I | TWRCK - 150 (ps) | TWRCK + 150 (ps) | t _{IP_CLK} | Figure 71 |

Table continues on the next page...

Table 125. Integrated flash controller IFC-NAND NVDDR interface AC timing specifications (OVDD = 1.8 V) (continued)

| Parameter | Symbol | I/O | Min | Max | Unit | Notes |
|--|----------|-----|----------------|----------------|---------------|-----------|
| WP# transition to command cycle | t_{WW} | O | TWW - 150 (ps) | TWW + 150 (ps) | t_{IP_CLK} | Figure 77 |
| NOTE: | | | | | | |
| 1. t_{IP_CLK} is the clock period of IP clock (on which IFC IP is running). Note that that the IFC IP clock doesn't come out of device. | | | | | | |

The following diagrams show the AC timing for the IFC-NAND NVDDR interface.

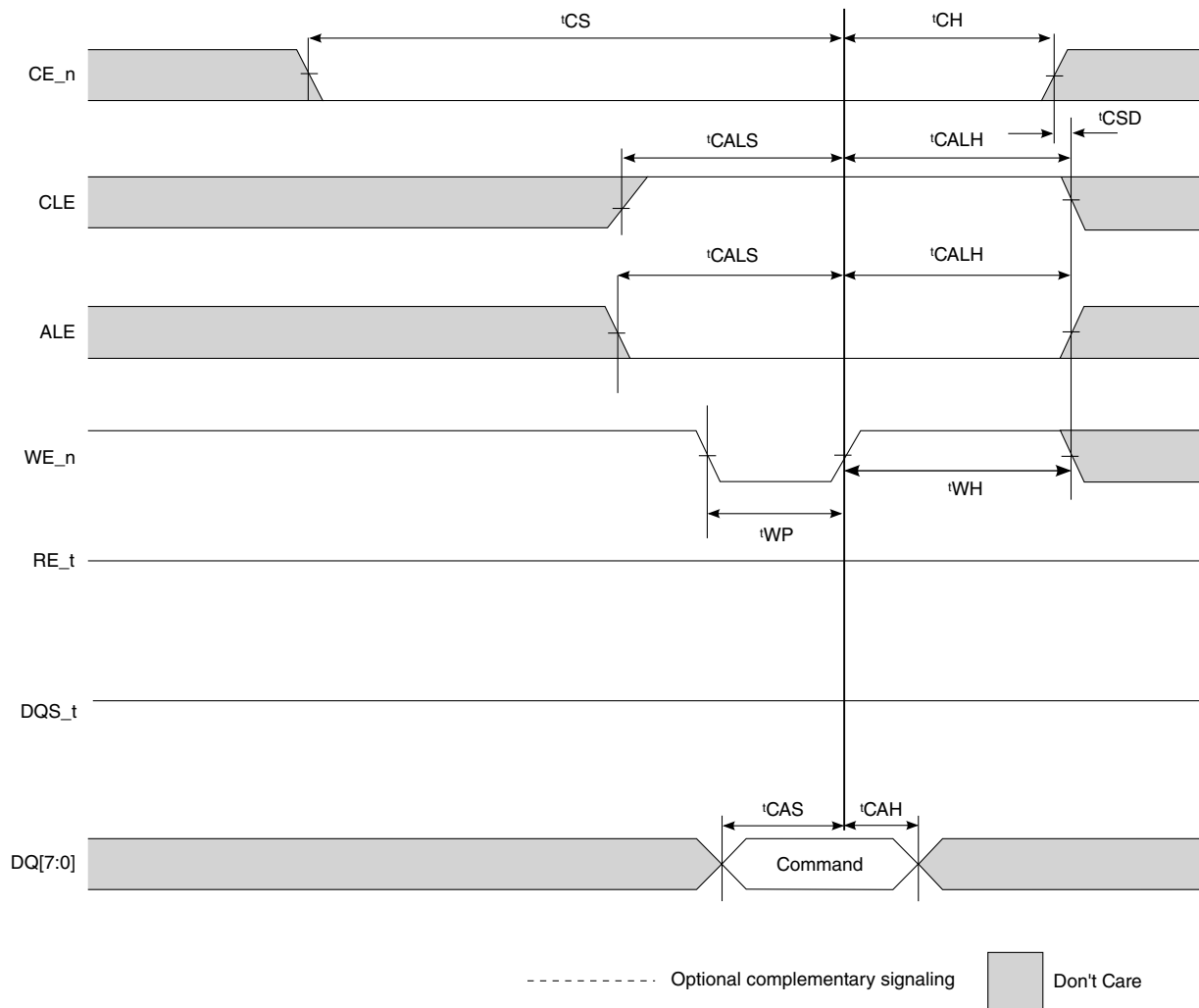

Figure 68. Command cycle

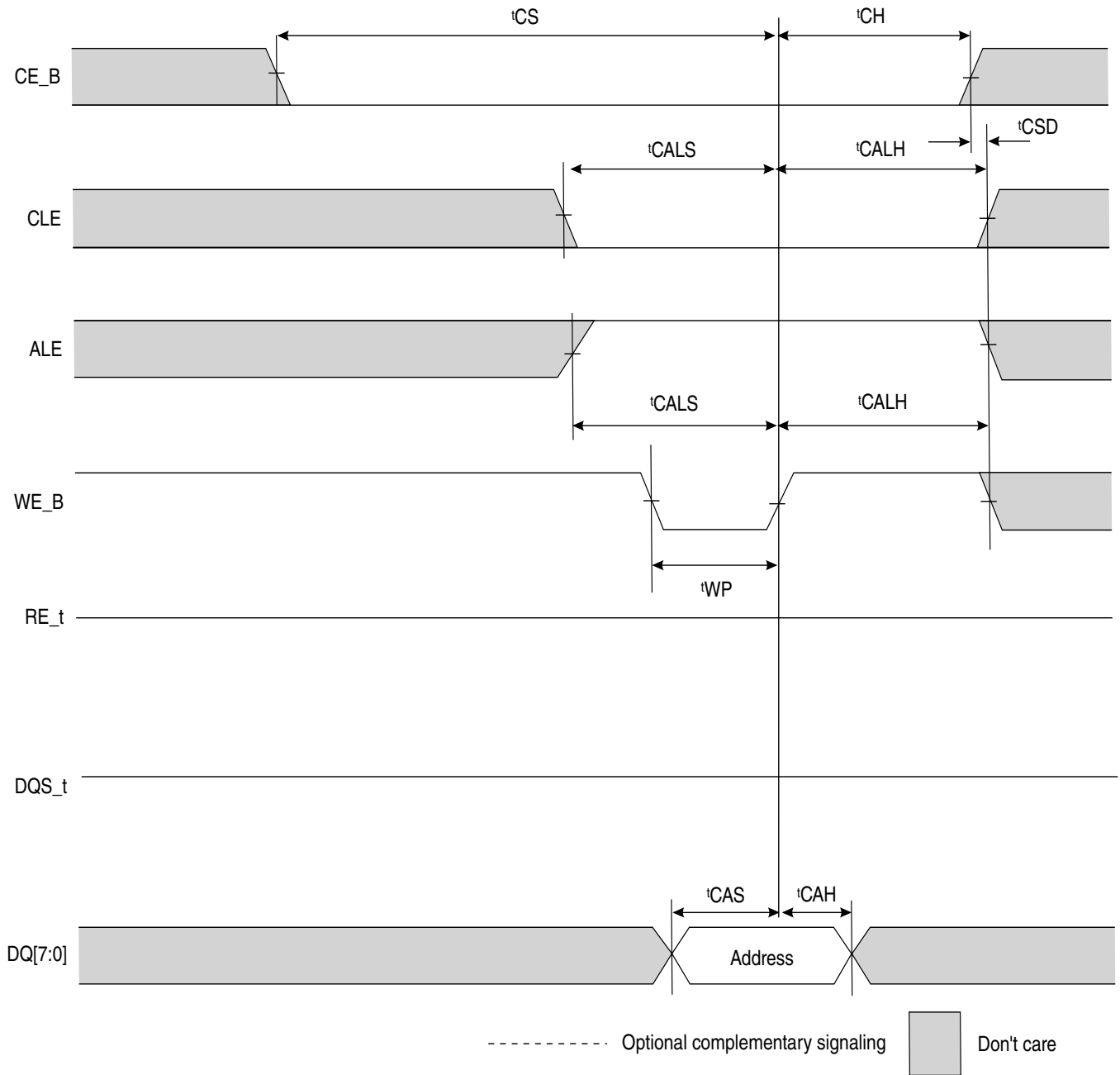

Figure 69. Address cycle

Electrical characteristics



Figure 70. Write cycle

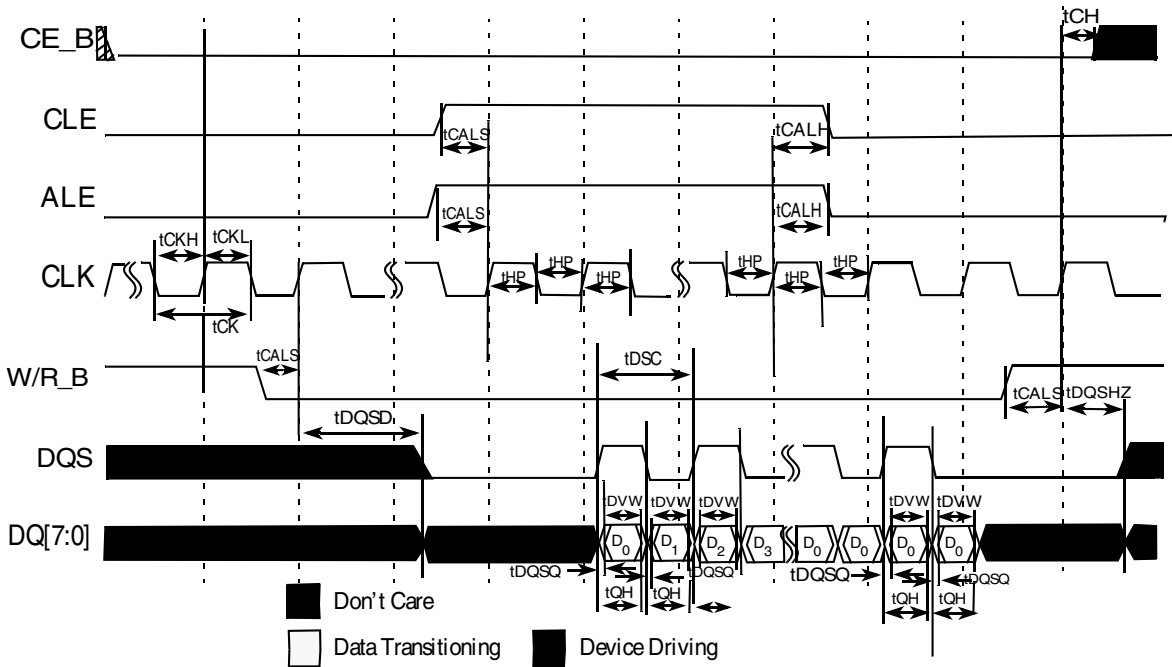

Figure 71. Read cycle



Figure 72. t_{ADL} timings



Figure 73. t_{WB} , t_{FEAT} , t_{ITC} , t_{RR} timings



Figure 74. t_{RHW} timings

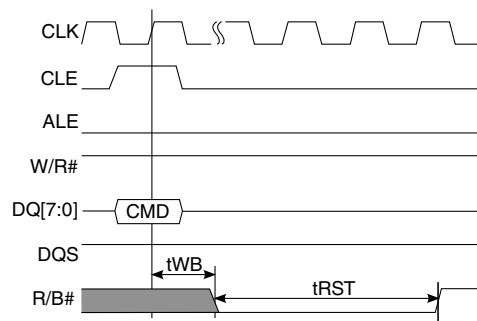

Figure 75. t_{WB} and t_{RST} timings



Figure 76. tWHR timings



Figure 77. tWW timings

3.19 JTAG interface

This section describes the DC and AC electrical specifications for the JTAG (IEEE 1149.1) interface.

3.19.1 JTAG DC electrical characteristics

This table provides the DC electrical characteristics for the JTAG interface operating at $OV_{DD} = 1.8\text{ V}$.

Table 126. JTAG DC electrical characteristics ($OV_{DD} = 1.8\text{ V}$)¹

| Parameter | Symbol | Min | Max | Unit | Notes |
|--|----------|----------------------|----------------------|---------------|-------|
| Input high voltage | V_{IH} | $0.7 \times OV_{DD}$ | - | V | 2 |
| Input low voltage | V_{IL} | - | $0.3 \times OV_{DD}$ | V | 2 |
| Input current ($V_{IN} = 0\text{V}$ or $V_{IN} = OV_{DD}$) | I_{IN} | - | -100/+50 | μA | 3, 4 |
| Output high voltage ($OV_{DD} = \text{min}$, $I_{OH} = -0.5\text{ mA}$) | V_{OH} | 1.35 | - | V | - |
| Output low voltage ($OV_{DD} = \text{min}$, $I_{OL} = 0.5\text{ mA}$) | V_{OL} | - | 0.4 | V | - |

Table continues on the next page...

Table 126. JTAG DC electrical characteristics ($OV_{DD} = 1.8 V$)¹ (continued)

| Parameter | Symbol | Min | Max | Unit | Notes |
|---|--------|-----|-----|------|-------|
| 1. For recommended operating conditions, see Table 3 . | | | | | |
| 2. Note that the min V_{IL} and max V_{IH} values are based on the respective min and max OV_{IN} values found in the Recommended Operating Conditions table. | | | | | |
| 3. Note that the symbol V_{IN} , in this case, represents the OV_{IN} symbol found in the Recommended Operating Conditions table. | | | | | |
| 4. TDI, TMS, and TRST_B have internal pull-ups per the IEEE Std. 1149.1 specification. | | | | | |

3.19.2 JTAG AC timing specifications

This table provides the JTAG AC timing specifications as defined in [Figure 78](#), [Figure 79](#), [Figure 80](#), and [Figure 81](#).

Table 127. JTAG AC timing specifications¹

| Parameter | Symbol | Min | Max | Unit | Notes |
|---|---------------------|------|------|------|---|
| JTAG external clock frequency of operation | F_{JTG} | 0.0 | 33.3 | MHz | - |
| JTAG external clock cycle time | t_{JTG} | 30.0 | - | ns | - |
| JTAG external clock pulse width measured at 1.4 V | t_{JTKHKL} | 15.0 | - | ns | - |
| JTAG external clock rise and fall times | t_{JTGR}/t_{JTGF} | 0.0 | 2.0 | ns | - |
| TRST_B assert time | t_{TRST} | 25.0 | - | ns | TRST_B is an asynchronous level sensitive signal. The setup time is for test purposes only. |
| Input setup times | t_{JTDVKH} | 4.0 | - | ns | TA_BB_TMP_DETECT pin requires 13.5ns input setup time for the board JTAG test to go through runTESTIdle. |
| Input hold times | t_{JTDXKH} | 10.0 | - | ns | - |
| Output valid times: boundary-scan data | t_{JTKLDV} | - | 15.0 | ns | All outputs are measured from the midpoint voltage of the falling edge of t_{TCLK} to the midpoint of the signal in question. The output timings are measured at the pins. All output timings assume a purely resistive 50- Ω load. Time-of-flight delays must be added for trace lengths, vias, and connectors in the system. |
| Output valid times: TDO | t_{JTKLDV} | - | 10.0 | ns | All outputs are measured from the midpoint voltage of the falling edge of t_{TCLK} to the midpoint of the signal in |

Table continues on the next page...

Table 127. JTAG AC timing specifications¹ (continued)

| Parameter | Symbol | Min | Max | Unit | Notes |
|-------------------|--------------|-----|-----|------|---|
| | | | | | question. The output timings are measured at the pins. All output timings assume a purely resistive 50-Ω load. Time-of-flight delays must be added for trace lengths, vias, and connectors in the system. |
| Output hold times | t_{JTKLDX} | 0.0 | - | ns | All outputs are measured from the midpoint voltage of the falling edge of t_{TCLK} to the midpoint of the signal in question. The output timings are measured at the pins. All output timings assume a purely resistive 50-Ω load. Time-of-flight delays must be added for trace lengths, vias, and connectors in the system. |

1. The symbols used for timing specifications follow these patterns: $t_{(first\ two\ letters\ of\ functional\ block)(signal)(state)(reference)(state)}$ for inputs and $t_{(first\ two\ letters\ of\ functional\ block)(reference)(state)(signal)(state)}$ for outputs. For example, t_{JTDVKH} symbolizes JTAG device timing (JT) with respect to the time data input signals (D) reaching the valid state (V) relative to the tJTG clock reference (K) going to the high (H) state or setup time. Also, t_{JTDXKH} symbolizes JTAG timing (JT) with respect to the time data input signals (D) reaching the invalid state (X) relative to the tJTG clock reference (K) going to the high (H) state. Note that, in general, the clock reference symbol representation is based on three letters representing the clock of a particular function. For rise and fall times, the latter convention is used with the appropriate letter: R (rise) or F (fall).

This figure shows the AC test load for TDO and the boundary-scan outputs of the device.



Figure 78. AC test load for the JTAG interface

This figure shows the JTAG clock input timing diagram.

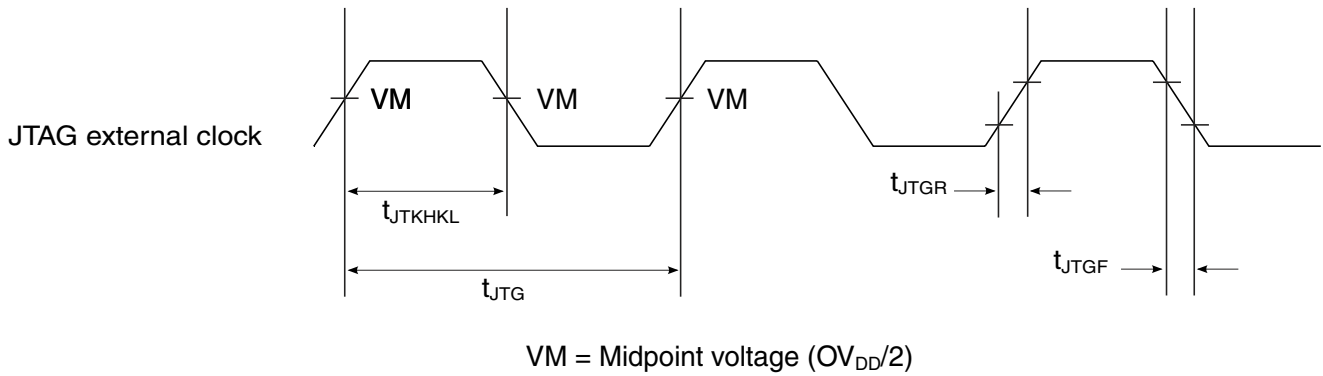

Figure 79. JTAG clock input timing diagram

This figure shows the TRST_B timing diagram.



Figure 80. TRST_B timing diagram

This figure shows the boundary-scan timing diagram.



Figure 81. Boundary-scan timing diagram

3.20 Quad serial peripheral interface (QuadSPI)

This section describes the DC and AC electrical characteristics for the QuadSPI interface.

3.20.1 QuadSPI DC electrical characteristics

This table provides the DC electrical characteristics for the QuadSPI interface operating at $OV_{DD} = 1.8V$.

Table 128. QuadSPI DC electrical characteristics¹

| Parameter | Symbol | Min | Max | Unit | Notes |
|--|----------|----------------------|----------------------|---------|-------|
| Input high voltage | V_{IH} | $0.7 \times OV_{DD}$ | - | V | 2 |
| Input low voltage | V_{IL} | - | $0.3 \times OV_{DD}$ | V | 2 |
| Input current ($0V \leq V_{IN} \leq OV_{DD}$) | I_{IN} | - | ± 50 | μA | 3 |
| Output high voltage ($OV_{DD} = \text{min}$, $I_{OH} = -100 \mu A$) | V_{OH} | $OV_{DD} - 0.2$ | - | V | - |
| Output low voltage ($OV_{DD} = \text{min}$, $I_{OL} = 100 \mu A$) | V_{OL} | - | 0.2 | V | - |

1. For recommended operating conditions, see [Table 3](#).
 2. The min V_{IL} and max V_{IH} values are based on the respective min and max OV_{IN} values found in [Table 3](#).
 3. Note that the symbol OV_{IN} represents the input voltage of the supply referenced in the Recommended Operating Conditions table.

3.20.2 QuadSPI AC timing specifications

This section describes the QuadSPI timing specifications in both SDR and DDR modes. All data is based on a negative edge data launch from the device and a positive edge data capture, as shown in the timing figures in this section.

This table provides the QuadSPI input and output timing in SDR mode ($MCR[DQS_EN] = 0$, regarding to the 1st sample point. See $qSPI_SMPR[xSDLY, xSPHS]$ in the corresponding chip reference manual for different sampling points). Note that T represents the clock period, j represents $qSPI_FLSHCR[TCSH]$, and k depends on $qSPI_FLSHCR[TCSS]$.

Table 129. QuadSPI SDR mode input and output timing

| Parameter | Symbol | Min | Max | Unit |
|----------------------|---------------------|----------------|-----|------|
| Clock rise/fall time | T_{RISE}/T_{FALL} | 1.0 | - | ns |
| CS output hold time | $t_{NIKH0X2}$ | $-3.3 + j * T$ | - | ns |
| CS output delay | $t_{NIKH0V2}$ | $-3.0 + k * T$ | - | ns |

Table continues on the next page...

Table 129. QuadSPI SDR mode input and output timing (continued)

| Parameter | Symbol | Min | Max | Unit |
|---|--------------|-------|------|------|
| Setup time for incoming data | t_{NIIVKH} | 5.0 | - | ns |
| Hold time requirement for incoming data | t_{NIIXKH} | 1.0 | - | ns |
| Output data delay | t_{NIKHOV} | - | 1.95 | ns |
| Output data hold | t_{NIKHOX} | -1.45 | - | ns |

This table provides the QuadSPI input and output timing in SDR mode with internal DQS (MCR[DQS_EN]=1 with regard to the 1st sample point). Note that T represents the clock period, the value of i depends on qSPI_SMPR[xSDLY, xSPHS], j depends on qSPI_FLSHCR[TCSS], k depends on qSPI_FLSHCR[TCSS], T_{coars} depends on SCLK_CONFIG[7:5], and T_{tapx} depends on SOCCFG[7:0]/SOCCFG[23:16].

Table 130. QuadSPI SDR mode input and output timing

| Parameter | Symbol | Min | Max | Unit |
|---|---------------------|-----------------------------|------|------|
| Clock rise/fall time | T_{RISE}/T_{FALL} | 1.0 | - | ns |
| CS output hold time | $t_{NIKHOX2}$ | $-3.3 + j * T$ | - | ns |
| CS output delay | $t_{NIKHOV2}$ | $-3.0 + k * T$ | - | ns |
| Setup time for incoming data | t_{NIIVKH} | $2.5 - T_{coars} - T_{tap}$ | - | ns |
| Hold time requirement for incoming data | t_{NIIXKH} | $1 + T_{coars} + T_{tap}$ | - | ns |
| Output data delay | t_{NIKHOV} | - | 1.45 | ns |
| Output data hold | t_{NIKHOX} | -1.45 | - | ns |

This figure shows the QuadSPI AC timing in SDR mode.

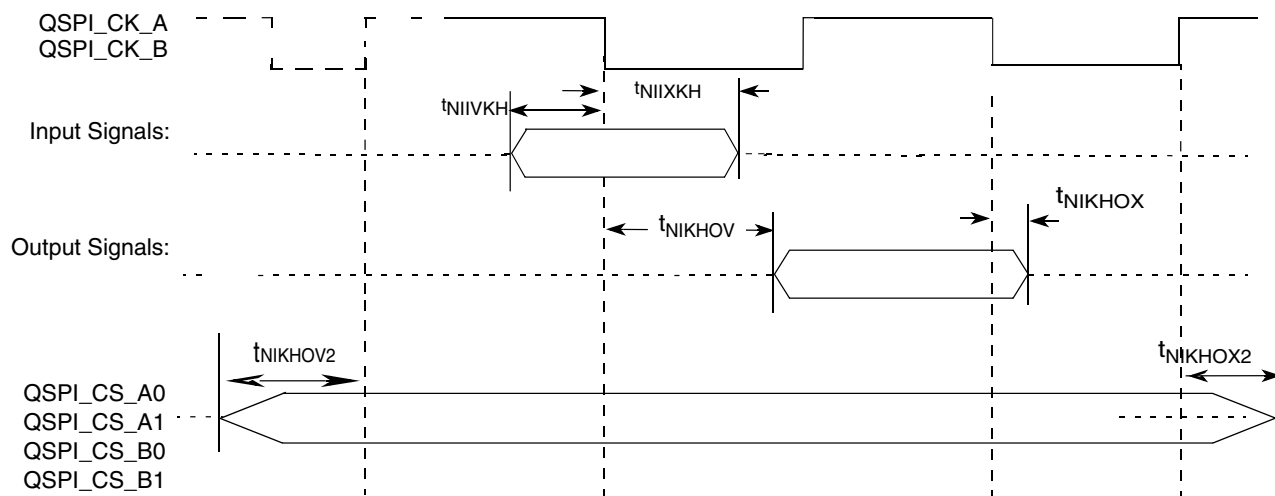
**Figure 82. QuadSPI AC timing — SDR mode**

Electrical characteristics

This table provides the QuadSPI input and output timing in DDR mode with external DQS/delay chain (MCR[DQS_EN] = 1, regarding to the 1st sample point). Note that T represents the clock period, j depends on the value of qSPI_FLSHCR[TCSH], k depends on qSPI_FLSHCR[TCSS], and m depends on QSPI_FLSHCR[TDH].

Table 131. QuadSPI DDR mode input and output timing

| Parameter | Symbol | Min | Max | Unit |
|----------------------|-----------------------|------------------|-----------------|------|
| Clock rise/fall time | T_{RISE}/T_{FALL} | 1.0 | - | ns |
| CS output hold time | $t_{NIKHOX2}$ | $3.3 + T * j$ | - | ns |
| CS output delay | $t_{NIKHOV2}$ | $-3.0 + k * T$ | - | ns |
| DQS to data skew | t_{NIDSH}/t_{NIDSL} | -0.9 | 0.9 | ns |
| Output data valid | t_{NIKHOV} | - | $0.9 + m * T/8$ | ns |
| Output data hold | t_{NIKHOX} | $-0.9 + m * T/8$ | - | ns |

This figure shows the QuadSPI AC timing in DDR mode.

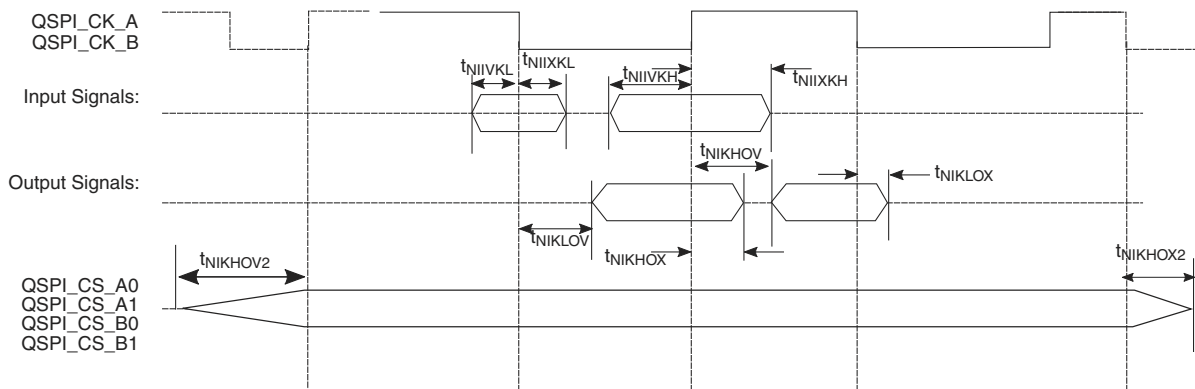

Figure 83. QuadSPI AC timing — DDR mode

This figure shows the QuadSPI data input timing in DDR mode with an external DQS.



Figure 84. QuadSPI input AC timing — DDR mode with an external DQS

This figure shows the QuadSPI clock input timing diagram.



Figure 85. QuadSPI clock input timing diagram

This figure shows the AC test load for QuadSPI.



Figure 86. AC test load for QuadSPI

3.21 QUICC engine specifications

The rise/fall time on QUICC engine block input pins should not exceed 5 ns. This should be enforced especially on clock signals. Rise time refers to signal transitions from 10% to 90% of V_{DD} . Fall time refers to transitions from 90% to 10% of V_{DD} .

3.21.1 High-level data link control (HDLC) interface

This section describes the DC and AC electrical characteristics for the high-level data link control (HDLC) interface.

3.21.1.1 HDLC DC electrical characteristics

This table provides the DC electrical characteristics for the HDLC and synchronous UART protocols when operating at $DV_{DD} = 3.3 \text{ V}$.

Electrical characteristics

Table 132. HDLC and synchronous UART DC electrical characteristics ($DV_{DD} = 3.3\text{ V}$)¹

| Parameter | Symbol | Min | Max | Unit | Notes |
|--|----------|----------------------|----------------------|---------------|-------|
| Input high voltage | V_{IH} | $0.7 \times DV_{DD}$ | - | V | 2 |
| Input low voltage | V_{IL} | - | $0.2 \times DV_{DD}$ | V | 2 |
| Input current ($V_{IN} = 0\text{V}$ or $V_{IN} = DV_{DD}$) | I_{IN} | -50 | 50 | μA | 3 |
| Output high voltage ($DV_{DD}=\text{min}$, $I_{OH} = -2\text{ mA}$) | V_{OH} | 2.4 | - | V | - |
| Output low voltage ($DV_{DD}=\text{min}$, $I_{OL} = 2\text{ mA}$) | V_{OL} | - | 0.4 | V | - |

1. For recommended operating conditions, see [Table 3](#).
 2. The min V_{IL} and max V_{IH} values are based on the respective min and max DV_{IN} values found in [Table 3](#).
 3. The symbol V_{IN} represents the input voltage of the supply referenced in [Table 3](#).

This table provides the DC electrical characteristics for the HDLC and Synchronous UART protocols when $DV_{DD} = 1.8\text{ V}$.

Table 133. HDLC and synchronous UART DC electrical characteristics ($DV_{DD} = 1.8\text{ V}$)¹

| Parameter | Symbol | Min | Max | Unit | Notes |
|--|----------|----------------------|----------------------|---------------|-------|
| Input high voltage | V_{IH} | $0.7 \times DV_{DD}$ | - | V | 2 |
| Input low voltage | V_{IL} | - | $0.3 \times DV_{DD}$ | V | 2 |
| Input current ($V_{IN} = 0\text{V}$ or $V_{IN} = DV_{DD}$) | I_{IN} | -50 | 50 | μA | 3 |
| Output high voltage ($DV_{DD}=\text{min}$, $I_{OH} = -2\text{ mA}$) | V_{OH} | 1.35 | - | V | - |
| Output low voltage ($DV_{DD}=\text{min}$, $I_{OL} = 2\text{ mA}$) | V_{OL} | - | 0.45 | V | - |

1. For recommended operating conditions, see [Table 3](#).
 2. The min V_{IL} and max V_{IH} values are based on the respective min and max DV_{IN} values found in [Table 3](#).
 3. The symbol V_{IN} represents the input voltage of the supply referenced in [Table 3](#).

3.21.1.2 HDLC and synchronous UART AC timing specifications

NOTE

Output specifications are measured from the 50% level of the rising edge of CLKIN to the 50% level of the signal. Timings are measured at the pin.

This table provides the input and output AC timing specifications for the HDLC and synchronous UART protocols.

Table 134. HDLC AC timing specifications

| Parameter | Symbol | Min | Max | Unit |
|---------------------------------|--------------|------|------|------|
| Internal clock delay | t_{HIKHOV} | 0.0 | 5.5 | - |
| External clock delay | t_{HEKHOV} | 1.0 | 13.0 | ns |
| Internal clock high impedance | t_{HIKHOX} | 0.0 | 5.5 | ns |
| External clock high impedance | t_{HEKHOX} | 1.0 | 8.0 | ns |
| Internal clock input setup time | t_{HIIVKH} | 12.6 | - | ns |
| External clock input setup time | t_{HEIVKH} | 4.0 | - | ns |
| Internal clock input hold time | t_{HIIXKH} | 0.0 | - | ns |
| External clock input hold time | t_{HEIXKH} | 1.0 | - | ns |

This table provides the input and output AC timing specifications for the synchronous UART protocols.

Table 135. Synchronous UART AC timing specifications

| Parameter | Symbol | Min | Max | Unit |
|---------------------------------|--------------|------|------|------|
| Internal clock delay | t_{HIKHOV} | 0.0 | 11.0 | - |
| External clock delay | t_{HEKHOV} | 1.0 | 14.0 | ns |
| Internal clock high impedance | t_{HIKHOX} | 0.0 | 11.0 | ns |
| External clock high impedance | t_{HEKHOX} | 1.0 | 14.0 | ns |
| Internal clock input setup time | t_{HIIVKH} | 10.0 | - | ns |
| External clock input setup time | t_{HEIVKH} | 8.0 | - | ns |
| Internal clock input hold time | t_{HIIXKH} | 0.0 | - | ns |
| External clock input hold time | t_{HEIXKH} | 1.0 | - | ns |

This figure shows the AC test load for the HDLC interface.

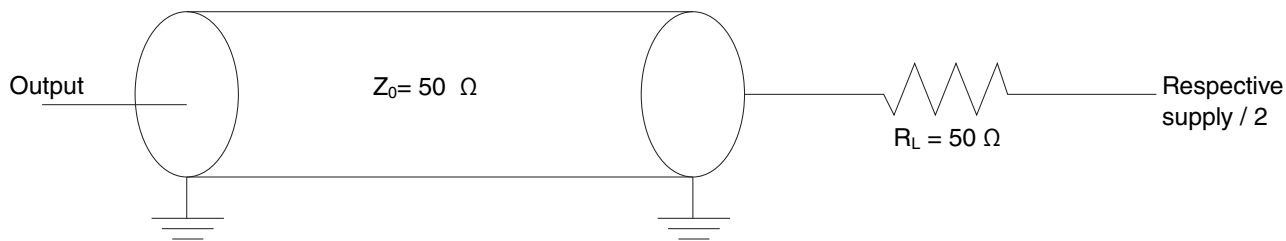
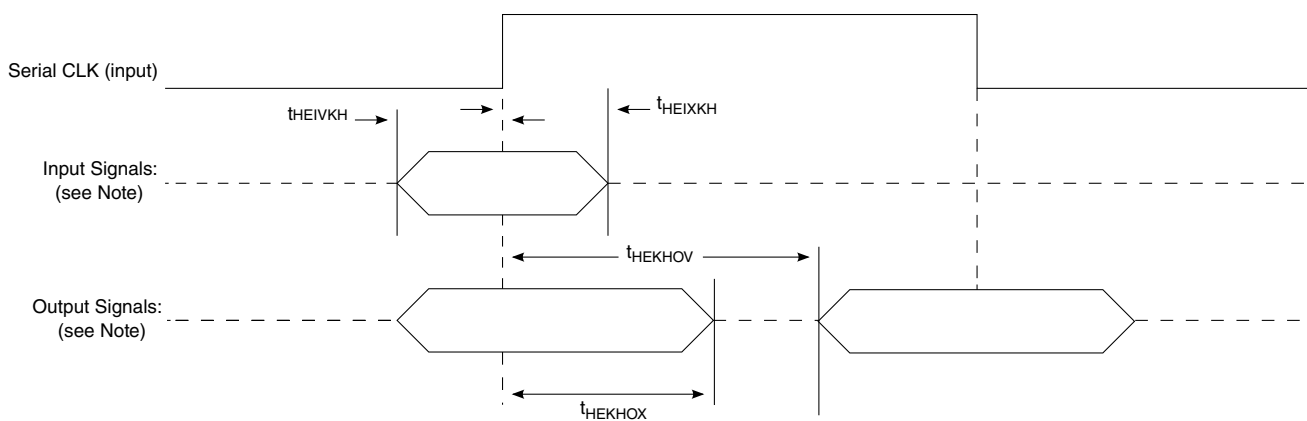

Figure 87. AC test load for HDLC

These figures represent the AC timing from the tables in section HDLC and synchronous UART AC timing specifications. Note that, although the specifications generally reference the rising edge of the clock, these AC timing diagrams also apply when the falling edge is the active edge.

This figure shows the timing with an external clock.



Note: The clock edge is selectable.

Figure 88. AC timing (external clock) diagram

This figure shows the timing with an internal clock.



Note: The clock edge is selectable.

Figure 89. AC timing (internal clock) diagram

3.21.2 Time division multiplexed/serial interface (TDM/SI)

This section describes the DC and AC electrical characteristics for the TDM/SI interface.

3.21.2.1 TDM/SI DC electrical characteristics

This table provides the DC electrical characteristics for the TDM/SI interface when operating at $DV_{DD} = 3.3$ V.

Table 136. TDM/SI DC electrical characteristics ($DV_{DD} = 3.3$ V)¹

| Parameter | Symbol | Min | Max | Unit | Notes |
|--|----------|-----------------|-----------------|---------|-------|
| Input high voltage | V_{IH} | 0.7 x DV_{DD} | - | V | 2 |
| Input low voltage | V_{IL} | - | 0.2 x DV_{DD} | V | 2 |
| Input current ($V_{IN} = 0$ V or $V_{IN} = DV_{DD}$) | I_{IN} | -50 | 50 | μ A | 3 |
| Output high voltage ($DV_{DD} = \text{min}$, $I_{OH} = -2$ mA) | V_{OH} | 2.4 | - | V | - |
| Output low voltage ($DV_{DD} = \text{min}$, $I_{OL} = 2$ mA) | V_{OL} | - | 0.4 | V | - |

1. For recommended operating conditions, see Table 3.

2. The min V_{IL} and max V_{IH} values are based on the respective min and max DV_{IN} values found in Table 3.

3. The symbol V_{IN} represents the input voltage of the supply referenced in Table 3.

This table provides the TDM/SI DC electrical characteristics when $DV_{DD} = 1.8$ V.

Table 137. TDM/SI DC electrical characteristics ($DV_{DD} = 1.8\text{ V}$)¹

| Parameter | Symbol | Min | Max | Unit | Notes |
|--|----------|-----------------------|-----------------------|---------------|-------|
| Input high voltage | V_{IH} | $0.65 \times DV_{DD}$ | - | V | 2 |
| Input low voltage | V_{IL} | - | $0.35 \times DV_{DD}$ | V | 2 |
| Input current ($V_{IN} = 0\text{V}$ or $V_{IN} = DV_{DD}$) | I_{IN} | -50 | 50 | μA | 3 |
| Output high voltage ($DV_{DD}=\text{min}$, $I_{OH} = -0.5\text{ mA}$) | V_{OH} | 1.35 | - | V | - |
| Output low voltage ($DV_{DD}=\text{min}$, $I_{OL} = 0.5\text{ mA}$) | V_{OL} | - | 0.4 | V | - |

1. For recommended operating conditions, see [Table 3](#).
2. The min V_{IL} and max V_{IH} values are based on the respective min and max DV_{IN} values found in [Table 3](#).
3. The symbol V_{IN} represents the input voltage of the supply referenced in [Table 3](#).

3.21.2.2 TDM/SI AC timing specifications

NOTE

Output specifications are measured from the 50% level of the rising edge of CLKIN to the 50% level of the signal. Timings are measured at the pin.

This table provides the AC timing specifications for the TDM/SI interface.

Table 138. TDM/SI AC timing specifications

| Parameter | Symbol | Min | Max | Unit |
|---------------------------------|--------------|-----|------|------|
| External clock delay | t_{SEKHOV} | 2.0 | 11.0 | ns |
| External clock high impedance | t_{SEKHOX} | 2.0 | 10.0 | ns |
| External clock input setup time | t_{SEIVKH} | 5.0 | - | ns |
| External clock input hold time | t_{SEIXKH} | 2.0 | - | ns |

This figure shows the AC test load for the TDM/SI.

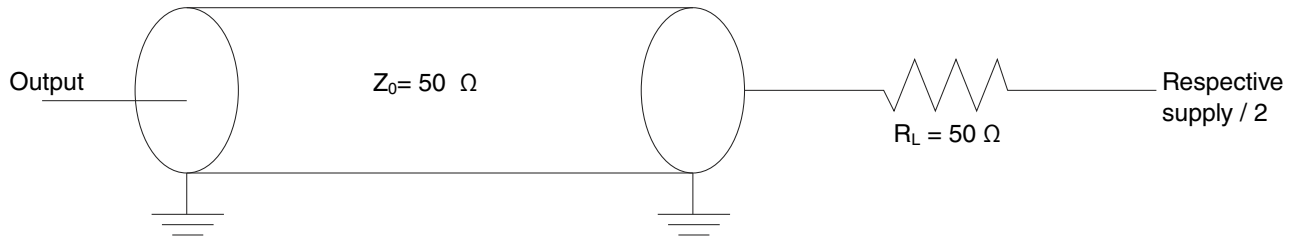

Figure 90. TDM/SI AC test load

This figure represents the AC timing from the TDM/SI AC timing specifications table. Note that, although the specifications generally reference the rising edge of the clock, these AC timing diagrams also apply when the falling edge is the active edge.

This figure shows the TDM/SI timing with an external clock.



Note: The clock edge is selectable on TDM/SI.

Figure 91. TDM/SI AC timing (external clock) diagram

3.22 Serial peripheral interface (SPI)

This section describes the DC and AC electrical characteristics for the SPI interface.

3.22.1 SPI DC electrical characteristics

This table provides the DC electrical characteristics for the SPI interface operating at $OV_{DD} = 1.8 \text{ V}$.

Electrical characteristics

Table 139. SPI DC electrical characteristics ($OV_{DD} = 1.8\text{ V}$)¹

| Parameter | Symbol | Min | Max | Unit | Notes |
|--|----------|----------------------|----------------------|---------------|-------|
| Input high voltage | V_{IH} | $0.7 \times OV_{DD}$ | - | V | 2 |
| Input low voltage | V_{IL} | - | $0.3 \times OV_{DD}$ | V | 2 |
| Input current ($V_{IN} = 0\text{V}$ or $V_{IN} = OV_{DD}$) | I_{IN} | - | ± 50 | μA | 3 |
| Output high voltage ($OV_{DD} = \text{min}$, $I_{OH} = -0.5\text{ mA}$) | V_{OH} | 1.35 | - | V | - |
| Output low voltage ($OV_{DD} = \text{min}$, $I_{OL} = 0.5\text{ mA}$) | V_{OL} | - | 0.4 | V | - |

1. For recommended operating conditions, see [Table 3](#).

2. Note that the min V_{IL} and max V_{IH} values are based on the respective min and max OV_{IN} values found in the Recommended Operating Conditions table.

3. Note that the symbol OV_{IN} represents the input voltage of the supply referenced in the Recommended Operating Conditions table.

3.22.2 SPI AC timing specifications

This table provides the AC timing specifications for the SPI interface when operating with a single master device.

Table 140. SPI AC timing specifications

| Parameter | Symbol | Min | Condition | Max | Unit |
|--|--------------|------|-----------|-----|------|
| SCK clock pulse width | t_{SDC} | 40 | - | 60 | % |
| CS to SCK delay | t_{CSC} | 16.0 | Master | - | ns |
| After SCK delay | t_{ASC} | 16.0 | Master | - | ns |
| Slave access time (SS active to SOUT driven) | t_A | - | Slave | 15 | ns |
| Slave disable time (SS inactive to SOUT High-Z or invalid) | t_{DI} | - | Slave | 10 | ns |
| Data setup time for inputs | t_{NIIVKH} | 9.0 | Master | - | ns |
| Data setup time for inputs | t_{NEIVKH} | 8.0 | Slave | - | ns |
| Data hold time for inputs | t_{NIIXKH} | 0.0 | Master | - | ns |
| Data hold time for inputs | t_{NEIXKH} | 2.0 | Slave | - | ns |
| Data valid (after SCK edge) for outputs | t_{NIKHOV} | - | Master | 5.0 | ns |

Table continues on the next page...

Table 140. SPI AC timing specifications (continued)

| Parameter | Symbol | Min | Condition | Max | Unit |
|---|--------------|-----|-----------|-----|------|
| Data valid (after SCK edge) for outputs | t_{NEKHOV} | - | Slave | 7.6 | ns |
| Data hold time for outputs | t_{NIKHOX} | 0.0 | Master | - | ns |
| Data hold time for outputs | t_{NEKHOX} | 0.0 | Slave | - | ns |

This figure shows the SPI timing master when $CPHA = 0$.



Figure 92. SPI timing master, CPHA = 0

This figure shows the SPI timing master when $CPHA = 1$.



Figure 93. SPI timing master, CPHA = 1

3.23 Universal serial bus (USB) interface

This section describes the DC and AC electrical characteristics for the USB interface.

3.23.1 USB 3.0 interface

This section describes the electrical characteristics for the USB 3.0 interface.

3.23.1.1 USB 3.0 DC electrical characteristics

This table provides the DC electrical characteristics for the USB 3.0 interface when operating at $USB_HV_{DD} = 3.3\text{ V}$.

Table 141. USB 3.0 PHY transceiver supply DC voltage (USB_HV_{DD} = 3.3 V)¹

| Parameter | Symbol | Min | Max | Unit | Notes |
|---|-----------------|-------|------|------|-------|
| Input high voltage | V _{IH} | 2.0 | - | V | 2 |
| Input low voltage | V _{IL} | - | 0.8 | V | 2 |
| Input current (USB_HVIN = 0V or USB_HVIN = USB_HV _{DD}) | I _{IN} | -50.0 | 50.0 | μA | 3 |
| Output high voltage (USB_HV _{DD} = min, I _{OH} = -2 mA) | V _{OH} | 2.8 | - | V | - |
| Output low voltage (USB_HV _{DD} = min, I _{OL} = 2 mA) | V _{OL} | - | 0.3 | V | - |

1. For recommended operating conditions, see [Table 3](#).

2. The min V_{IL} and max V_{IH} values are based on the respective min and max USB_HVIN values found in [Table 3](#).

3. The symbol USB_HVIN represents the input voltage of the supply referenced in [Table 3](#).

This table provides the USB 3.0 transmitter DC electrical characteristics at package pins.

Table 142. USB 3.0 transmitter DC electrical characteristics¹

| Parameter | Symbol | Min | Typ | Max | Unit |
|---|--|-------|--------|--------|-------|
| Differential output voltage | V _{tx-diff-pp} | 800.0 | 1000.0 | 1200.0 | mVp-p |
| Low power differential output voltage | V _{tx-diff-pp-low} | 400.0 | - | 1200.0 | mVp-p |
| Transmit de-emphasis | V _{tx-de-ratio} | 3.0 | - | 4.0 | dB |
| Differential impedance | Z _{diffTX} | 72.0 | 100.0 | 120.0 | Ω |
| Transmit common mode impedance | R _{TX-DC} | 18.0 | - | 30.0 | Ω |
| Absolute DC common mode voltage between U1 and U0 | T _{TX-CM-DC-ACTIVEIDLE-DELTA} | - | - | 200.0 | mV |
| DC electrical idle differential output voltage | V _{TX-IDLE-DIFF-DC} | 0.0 | - | 10.0 | mV |

1. For recommended operating conditions, see [Table 3](#).

This table provides the USB 3.0 transmitter DC electrical characteristics at receiver package pins.

Table 143. USB 3.0 receiver DC electrical characteristics¹

| Parameter | Symbol | Min | Typ | Max | Unit | Notes |
|---|-----------------------------|---------|-------|-------|------|-------|
| Differential receiver input impedance | R _{RX-DIFF-DC} | 72.0 | 100.0 | 120.0 | Ω | - |
| Receiver DC common mode impedance | R _{RX-DC} | 18.0 | - | 30.0 | Ω | - |
| DC input CM input impedance for V _I > 0 during reset or power down | Z _{RX-HIGH-IMP-DC} | 25000.0 | - | - | Ω | - |

Table continues on the next page...

Table 143. USB 3.0 receiver DC electrical characteristics¹ (continued)

| Parameter | Symbol | Min | Typ | Max | Unit | Notes |
|-----------------------|------------------------------|-------|-----|-------|------|-------|
| LFPS detect threshold | $V_{TRX-IDLE-DET-DC-DIFFpp}$ | 100.0 | - | 300.0 | mV | 2 |

1. For recommended operating conditions, see [Table 3](#).
 2. Below the minimum is noise. Must wake up above the maximum.

3.23.1.2 USB 3.0 AC timing specifications

This table provides the USB 3.0 transmitter AC timing specifications at package pins.

Table 144. USB 3.0 transmitter AC timing specifications

| Parameter | Symbol | Min | Typ | Max | Unit | Notes |
|-----------------------|--------------|--------|-----|--------|------|--|
| Speed | - | - | 5.0 | - | Gb/s | - |
| Transmitter eye | T_{TX-EYE} | 0.625 | - | - | UI | - |
| Unit Interval | UI | 199.94 | - | 200.06 | ps | UI does not account for SSC-caused variations. |
| AC coupling capacitor | AC_{CAP} | 75.0 | - | 200.0 | nF | - |

This table provides the USB 3.0 receiver AC timing specifications at receiver package pins.

Table 145. USB 3.0 receiver AC timing specifications

| Parameter | Symbol | Min | Max | Unit | Notes |
|---------------|--------|--------|--------|------|--|
| Unit Interval | UI | 199.94 | 200.06 | ps | UI does not account for SSC-caused variations. |

3.23.1.3 USB 3.0 LFPS specifications

This table provides the key LFPS electrical specifications at the transmitter.

Table 146. LFPS electrical specifications at the transmitter

| Parameter | Symbol | Min | Max | Unit | Notes |
|-----------|--------------|------|-------|------|-------|
| Period | t_{Period} | 20.0 | 100.0 | ns | - |

Table continues on the next page...

Table 146. LFPS electrical specifications at the transmitter (continued)

| Parameter | Symbol | Min | Max | Unit | Notes |
|---|--------------------------|-------|--------|------|--|
| Peak-to-peak differential amplitude | $V_{tx-diff-pp-lfps}$ | 800.0 | 1200.0 | mV | - |
| Low-power peak-to-peak differential amplitude | $V_{tx-diff-pp-lfps-lp}$ | 400.0 | 600.0 | mV | - |
| Rise/fall time | $t_{rise/fall}$ | - | 4.0 | ns | Measured at compliance TP1. See the Transmit normative setup figure below for details. |
| Duty cycle | DC_{LFPS} | 40.0 | 60.0 | % | Measured at compliance TP1. See the Transmit normative setup figure below for details. |

This figure shows the Tx normative setup with reference channel per USB 3.0 specifications.

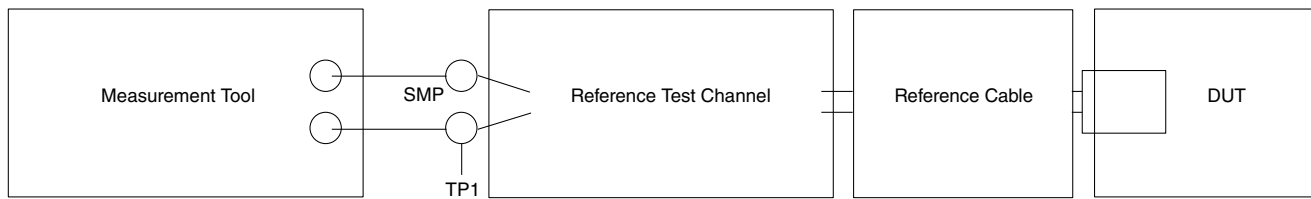
**Figure 94. Transmit normative setup**

4 Hardware design considerations

4.1 Clock ranges

This table provides the clocking specifications for the processor core, platform, memory, and integrated flash controller.

Table 147. Processor, platform, and memory clocking specifications

| Characteristic | Maximum processor core frequency | | | | | | Unit | Notes |
|--|----------------------------------|------|----------|------|----------|------|------|-------|
| | 1200 MHz | | 1400 MHz | | 1600 MHz | | | |
| | Min | Max | Min | Max | Min | Max | | |
| Core cluster group PLL frequency | 600 | 1200 | 600 | 1400 | 600 | 1600 | MHz | 1 |
| Platform clock frequency | 400 | 500 | 400 | 600 | 400 | 700 | MHz | 1 |
| Memory bus clock frequency | 650 | 800 | 650 | 900 | 650 | 1050 | MHz | 1, 2 |
| IFC clock frequency | - | 100 | - | 100 | - | 100 | MHz | 3 |
| <p>1. Caution:The coherency domain clock to SYSCLK ratio and core to SYSCLK ratio settings must be chosen such that the resulting SYSCLK frequency, core frequency, coherency domain and platform clock frequency do not exceed their respective maximum or minimum operating frequencies.</p> <p>2. The memory bus clock speed is half the DDR4 data rate.</p> <p>3. The integrated flash controller (IFC) clock speed on IFC_CLK[0:1] is determined by the platform clock divided by the IFC ratio programmed in CCR[CLKDIV]. See the chip reference manual for more information.</p> | | | | | | | | |

4.2 Power supply design

For additional details on the power supply design, see AN5144, QorIQ LS1088A Design Checklist.

4.2.1 Voltage ID (VID) controllable supply

To guarantee performance and power specifications, a specific method of selecting the optimum voltage-level must be implemented when the chip is used. As part of the chip's boot process, software must read the VID efuse values stored in the Fuse Status register (FUSESR) and then configure the external voltage regulator based on this information. This method requires a point of load voltage regulator for each chip. When VID option is used, the V_{DD} supply should be separated from the SerDes 1.0 V supply SnV_{DD} . It is required in order to control the V_{DD} supply only.

NOTE

During the power-on reset process, the fuse values are read and stored in the FUSESR. It is expected that the chip's boot code reads the FUSESR value very early in the boot sequence and updates the regulator accordingly.

The default voltage regulator setting that is safe for the system to boot is the recommended operating V_{DD} at initial start-up of 1.025 V. It is highly recommended to select a regulator with a V_{out} range of at least 0.9 V to 1.1 V, with a resolution of 12.5 mV or better, when implementing a VID solution.

The table below lists the valid VID fuse values that will be programmed at the factory for this chip.

Table 148. Fuse Status Register (DCFG_CCSR_FUSESR)

| Binary value of DA_V / DA_ALT_V | V _{DD} voltage |
|---------------------------------|-------------------------|
| 00000b | 1.025 V (default) |
| 00001b | 0.9875 V |
| 00010b | 0.9750 V |
| 01000b | 0.9000 V |
| 10000b | 1.0000 V |
| 10001b | 1.0125 V |
| 10010b | 1.0250 V |
| All other values | Reserved |

For additional information on VID, see the chip reference manual.

5 Thermal

This table shows the thermal characteristics for the chip. Note that these numbers are based on design estimates and are preliminary.

Table 149. Package thermal characteristics

| Rating | Board | Symbol | Value | Unit | Notes |
|---|-------------------------|---------------------|-------|------|-------|
| Junction-to-ambient, natural convection | Single-layer board (1s) | R _{ΘJA} | 23.5 | °C/W | 1 |
| Junction-to-ambient, natural convection | Four-layer board (2s2p) | R _{ΘJA} | 15.2 | °C/W | 1 |
| Junction-to-ambient (at 200 ft./min.) | Single-layer board (1s) | R _{ΘJMA} | 14.8 | °C/W | 1 |
| Junction-to-ambient (at 200 ft./min.) | Four-layer board (2s2p) | R _{ΘJMA} | 10.1 | °C/W | 1 |
| Junction-to-board | - | R _{ΘJB} | 4.4 | °C/W | 2 |
| Junction-to-case (top) | - | R _{ΘJCTop} | 0.56 | °C/W | 3 |
| Junction-to-lid-top | - | R _{ΘJClid} | 0.20 | °C/W | 4 |

- Junction-to-ambient thermal resistance determined per JEDEC JESD51-2A and JESD51-6. Thermal test board meets JEDEC specification for this package (JESD51-9).
- Junction-to-board thermal resistance determined per JEDEC JESD51-8. Thermal test board meets JEDEC specification for the specified package.
- Junction-to-case at the top of the package determined using MIL-STD 883 Method 1012.1. The cold plate temperature is used for the case temperature. Reported value includes the thermal resistance of the interface layer.
- Junction-to-lid-top thermal resistance is determined using the MIL-STD 883 Method 1012.1. However, instead of the cold plate, the lid top temperature is used here for the reference case temperature. Reported value does not include the thermal resistance layer between the package and cold plate.
- See [Thermal management information](#) for additional details.

5.1 Recommended thermal model

Information about Flotherm models of the package or thermal data not available in this document can be obtained from your local NXP sales office.

5.2 Temperature diode

The chip has a temperature diode on the microprocessor that can be used in conjunction with other system temperature monitoring devices (such as Analog Devices, ADT7461A). These devices feature series resistance cancellation using three current measurements, where up to 1.5 k Ω of resistance can be automatically cancelled from the temperature result, allowing noise filtering and a more accurate reading.

The following are the specifications of the chip's on-board temperature diode:

Operating range: TBD

Ideality factor TBD; Temperature range TBD

5.3 Thermal management information

This section provides thermal management information for the flip-chip, plastic-ball, grid array (FC-PBGA) package for air-cooled applications. Proper thermal control design is primarily dependent on the system-level design—the heat sink, airflow, and thermal interface material.

The recommended attachment method to the heat sink is illustrated in [Figure 95](#). The heat sink should be attached to the printed-circuit board with the spring force centered over the die. This spring force should not exceed 15 pounds force.

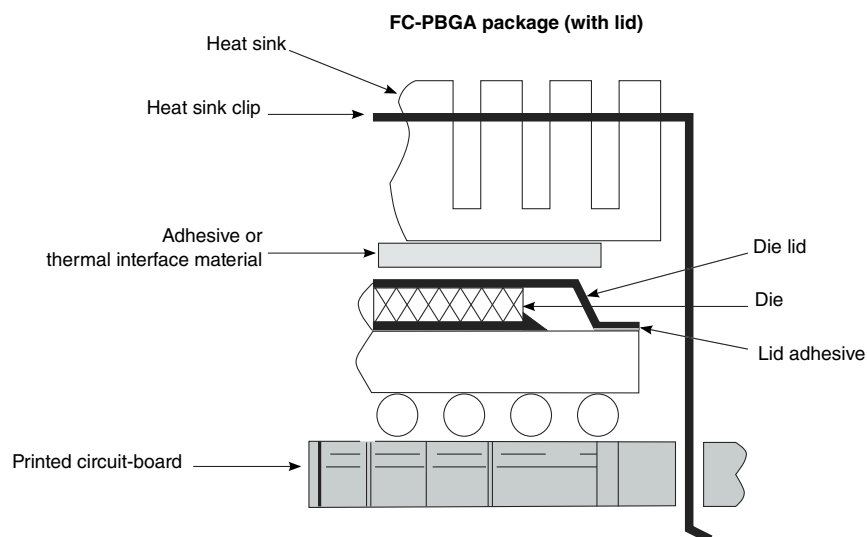

Figure 95. Package exploded, cross-sectional view-FC-PBGA (with lid)

The system board designer can choose between several types of heat sinks to place on the device. There are several commercially available thermal interfaces to choose from in the industry. Ultimately, the final selection of an appropriate heat sink depends on many factors, such as thermal performance at a given air velocity, spatial volume, mass, attachment method, assembly, and cost.

5.3.1 Internal package conduction resistance

For the package, the intrinsic internal conduction thermal resistance paths are as follows:

- The die junction-to-case thermal resistance
- The die junction-to-board thermal resistance

This figure shows the primary heat transfer path for a package with an attached heat sink mounted to a printed-circuit board.

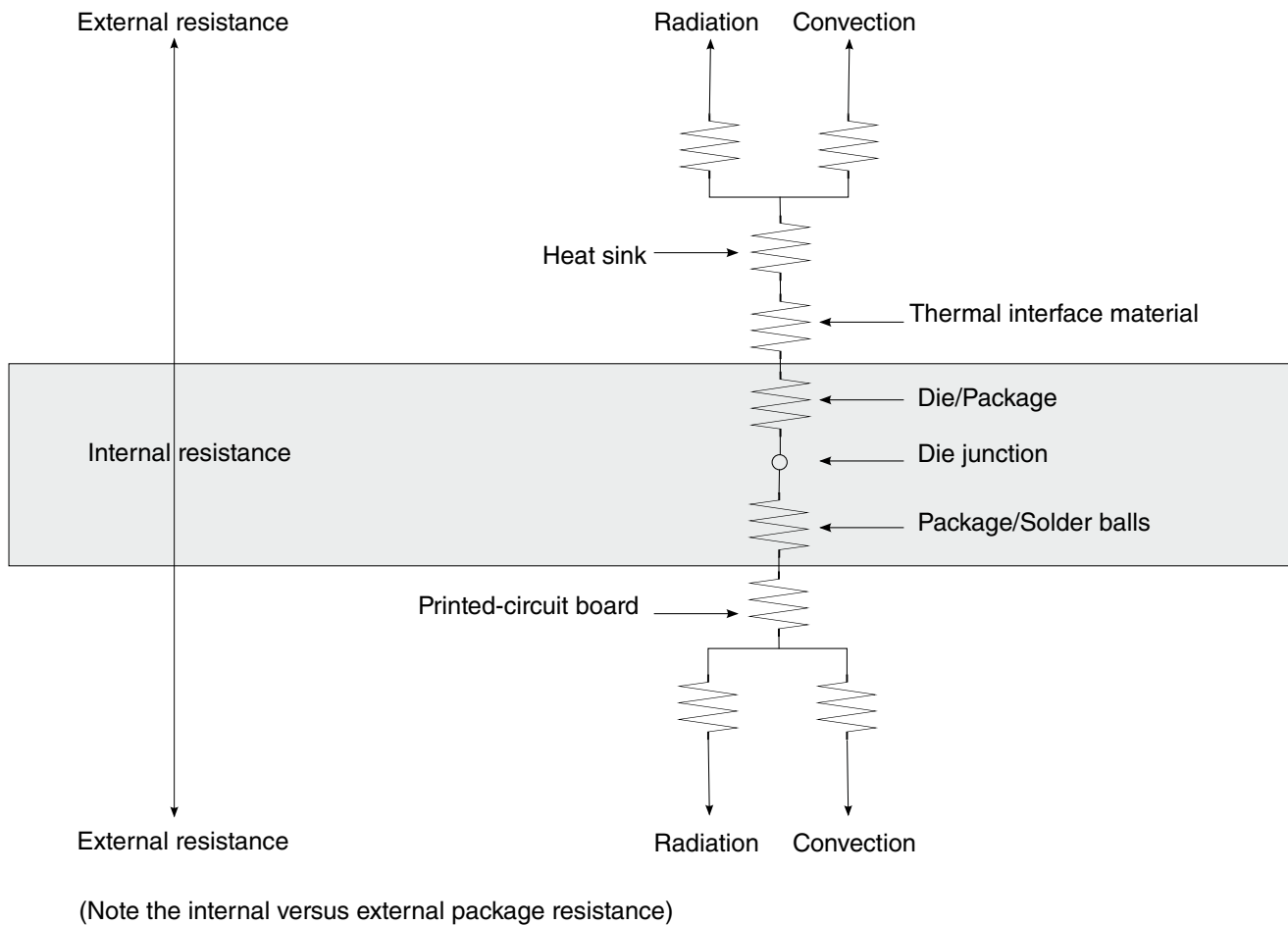

Figure 96. Package with heat sink mounted to a printed-circuit board

The heat sink removes most of the heat from the device. Heat generated on the active side of the chip is conducted through the silicon and through the heat sink attach material (or thermal interface material), and finally to the heat sink. The junction-to-case thermal resistance is low enough that the heat sink attach material and heat sink thermal resistance are the dominant terms.

5.3.2 Thermal interface materials

A thermal interface material is required at the package-to-heat sink interface to minimize the thermal contact resistance. The performance of thermal interface materials improves with increasing contact pressure; this performance characteristic chart is generally provided by the thermal interface vendor. The recommended method of mounting heat sinks on the package is by means of a spring clip attachment to the printed-circuit board (see [Figure 95](#)).

The system board designer can choose among several types of commercially available thermal interface materials.

6 Package information

6.1 Package parameters for the FC-PBGA

The package parameters are as provided in the following list. The package type is 23 mm x 23 mm, 780 flip-chip, plastic-ball, grid array.

- Package outline - 23 mm x 23 mm
- Interconnects - 780
- Ball Pitch - 0.8 mm
- Ball Diameter (nominal) - 0.45 mm
- Ball Height (nominal) - 0.3 mm
- Solder Balls Composition - 96.5% Sn, 3% Ag, 0.5% Cu
- Module height (typical) - 2.31 mm (minimum), 2.46 mm (typical), 2.61 mm (maximum)

6.2 Mechanical dimensions of the FC-PBGA

This figure shows the mechanical dimensions and bottom surface nomenclature of the chip.

Package information

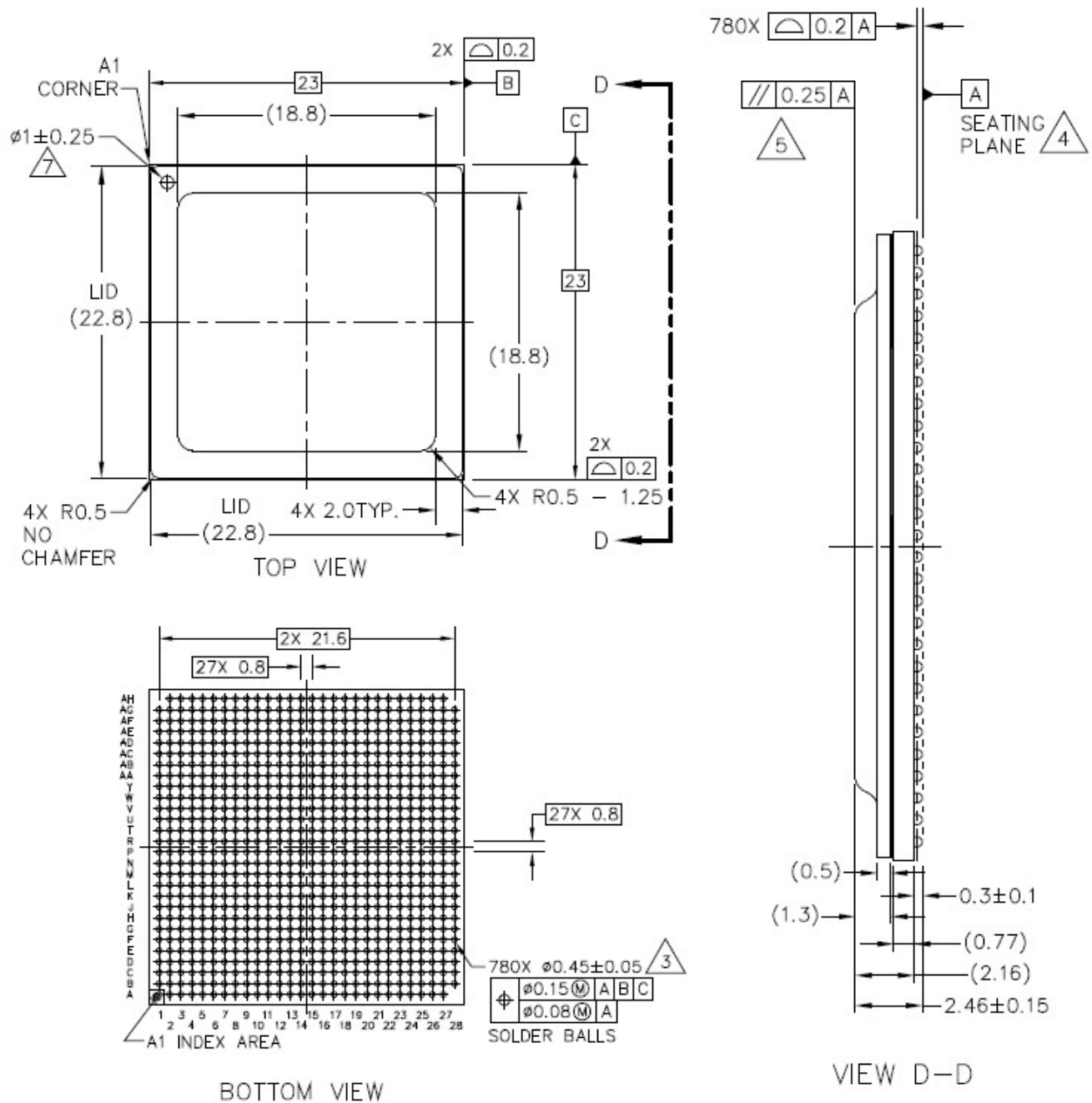

| | | |
|--|--------------------------|----------------------------|
| © FREESCALE SEMICONDUCTOR, INC. ALL RIGHTS RESERVED. | MECHANICAL OUTLINE | PRINT VERSION NOT TO SCALE |
| TITLE: FCPBGA, WITH LID, 23 X 23 X 2.46 PKG, 0.8 MM PITCH, 780 I/O | DOCUMENT NO: 98ASA00854D | REV: 0 |
| | STANDARD: NON-JEDEC | |
| | 03 DEC 2014 | |

Figure 97. Mechanical dimensions of the FC-PBGA

NOTES:

1. All dimensions are in millimeters.
2. Dimensions and tolerances per ASME Y14.5M-1994.
3. Maximum solder ball diameter measured parallel to datum A.
4. Datum A, the seating plane, is determined by the spherical crowns of the solder balls.
5. Parallelism measurement shall exclude any effect of mark on top surface of package.
6. All dimensions are symmetric across the package center lines, unless dimensioned otherwise.
7. Pin 1 thru hole shall be centered within foot area.
8. 23.2 mm maximum package assembly (lid + laminate) X and Y.

7 Security fuse processor

This chip implements trust architecture 3.0, which supports capabilities such as secure boot. Use of the trust architecture features is dependent on programming fuses in the Security Fuse Processor (SFP). The details of the trust architecture and SFP can be found in the chip reference manual.

To program SFP fuses, the user is required to supply 1.8 V to the TA_PROG_SFP pin per [Power sequencing](#). TA_PROG_SFP should only be powered for the duration of the fuse programming cycle, with a per device limit of two fuse programming cycles. All other times, TA_PROG_SFP should be connected to GND. The sequencing requirements for raising and lowering TA_PROG_SFP are shown in [Power sequencing](#). To ensure device reliability, fuse programming must be performed within the recommended fuse programming temperature range per [Table 3](#).

NOTE

Users not implementing the QorIQ platform's trust architecture features should connect TA_PROG_SFP to GND.

8 Ordering information

Contact your local NXP sales office or regional marketing team for order information.

8.1 Part numbering nomenclature

This table provides the NXP Layerscape platform part numbering nomenclature.

Table 150. Part numbering nomenclature

| <i>q</i> | <i>p</i> | <i>g</i> | <i>c</i> | <i>u</i> | <i>c</i> | <i>t</i> | <i>e</i> | <i>n</i> | <i>c</i> | <i>d</i> | <i>r</i> |
|--|--------------------|-------------------|-------------------------------------|-----------------------------------|-----------|--|--------------------------------------|--------------|--|--|-------------|
| Qual status | Product generation | Performance level | Number of cores | Unique ID | Core Type | Temperature Range | Encryption | Package type | CPU speed ¹ | DDR data rate | Revision |
| (blank) = Qualified P = Pre-qual | LS = Layerscape | 1 | 08 = Eight cores 04 = Four cores | 8 = with AIOP 4 = without AIOP | A = ARM | S = Standard (0–105°C) X = Extended (-40–105°C) | E = Encryption N = Non-Encryption | 7 = FC-PBGA | M = 1200 MHz P = 1400 MHz Q = 1600 MHz | Q = 1600 MHz T = 1800 MHz 1 = 2100 MHz | A = Rev 1.0 |
| 1. For the LS1088A family of devices, parts marked with "M" require 0.9 V operating voltage. All others require VID. | | | | | | | | | | | |

8.2 Part marking

Parts are marked as in the example shown in this figure.



FC-PBGA

Legend:

LS1088XXXXXXXXXX is the part marking on the die.
 ATWLYYWW is the test traceability code.
 MMMMM is the mask number.
 CCCCC is the country code.
 YWWLAZ is the assembly traceability code.

Figure 98. Part marking for FC-PBGA chip

9 Revision history

This table summarizes revisions to this document.

Table 151. Revision history

| Revision | Date | Description |
|----------|---------|------------------|
| 0 | 01/2018 | Initial release. |

How to Reach Us:**Home Page:**nxp.com**Web Support:**nxp.com/support

Information in this document is provided solely to enable system and software implementers to use NXP products. There are no express or implied copyright licenses granted hereunder to design or fabricate any integrated circuits based on the information in this document. NXP reserves the right to make changes without further notice to any products herein.

NXP makes no warranty, representation, or guarantee regarding the suitability of its products for any particular purpose, nor does NXP assume any liability arising out of the application or use of any product or circuit, and specifically disclaims any and all liability, including without limitation consequential or incidental damages. "Typical" parameters that may be provided in NXP data sheets and/or specifications can and do vary in different applications, and actual performance may vary over time. All operating parameters, including "typicals," must be validated for each customer application by customer's technical experts. NXP does not convey any license under its patent rights nor the rights of others. NXP sells products pursuant to standard terms and conditions of sale, which can be found at the following address: nxp.com/SalesTermsandConditions.

NXP, the NXP logo, NXP SECURE CONNECTIONS FOR A SMARTER WORLD, COOLFLUX, EMBRACE, GREENCHIP, HITAG, I2C BUS, ICODE, JCOP, LIFE VIBES, MIFARE, MIFARE CLASSIC, MIFARE DESFire, MIFARE PLUS, MIFARE FLEX, MANTIS, MIFARE ULTRALIGHT, MIFARE4MOBILE, MIGLO, NTAG, ROADLINK, SMARTLX, SMARTMX, STARPLUG, TOPFET, TRENCHMOS, UCODE, Freescale, the Freescale logo, AltiVec, C-5, CodeTEST, CodeWarrior, ColdFire, ColdFire+, C-Ware, the Energy Efficient Solutions logo, Kinetis, Layerscape, MagniV, mobileGT, PEG, PowerQUICC, Processor Expert, QorIQ, QorIQ Qonverge, Ready Play, SafeAssure, the SafeAssure logo, StarCore, Symphony, VortiQa, Vybrid, Airfast, BeeKit, BeeStack, CoreNet, Flexis, MXC, Platform in a Package, QUICC Engine, SMARTMOS, Tower, TurboLink, and UMEMS are trademarks of NXP B.V. All other product or service names are the property of their respective owners. Arm, AMBA, Artisan, Cortex, Jazelle, Keil, SecurCore, Thumb, TrustZone, and μ Vision are registered trademarks of Arm Limited (or its subsidiaries) in the EU and/or elsewhere. Arm7, Arm9, Arm11, big.LITTLE, CoreLink, CoreSight, DesignStart, Mali, Mbed, NEON, POP, Sensinode, Socrates, ULINK and Versatile are trademarks of Arm Limited (or its subsidiaries) in the EU and/or elsewhere. All rights reserved. Oracle and Java are registered trademarks of Oracle and/or its affiliates.

© 2015–2018 NXP B.V.

Document Number LS1088A
Revision 0, 01/2018

