

IDEAS GENERATED DRAWING, DO NOT CHANGE BY HAND

REV.	ECN.	NO.	APPD.

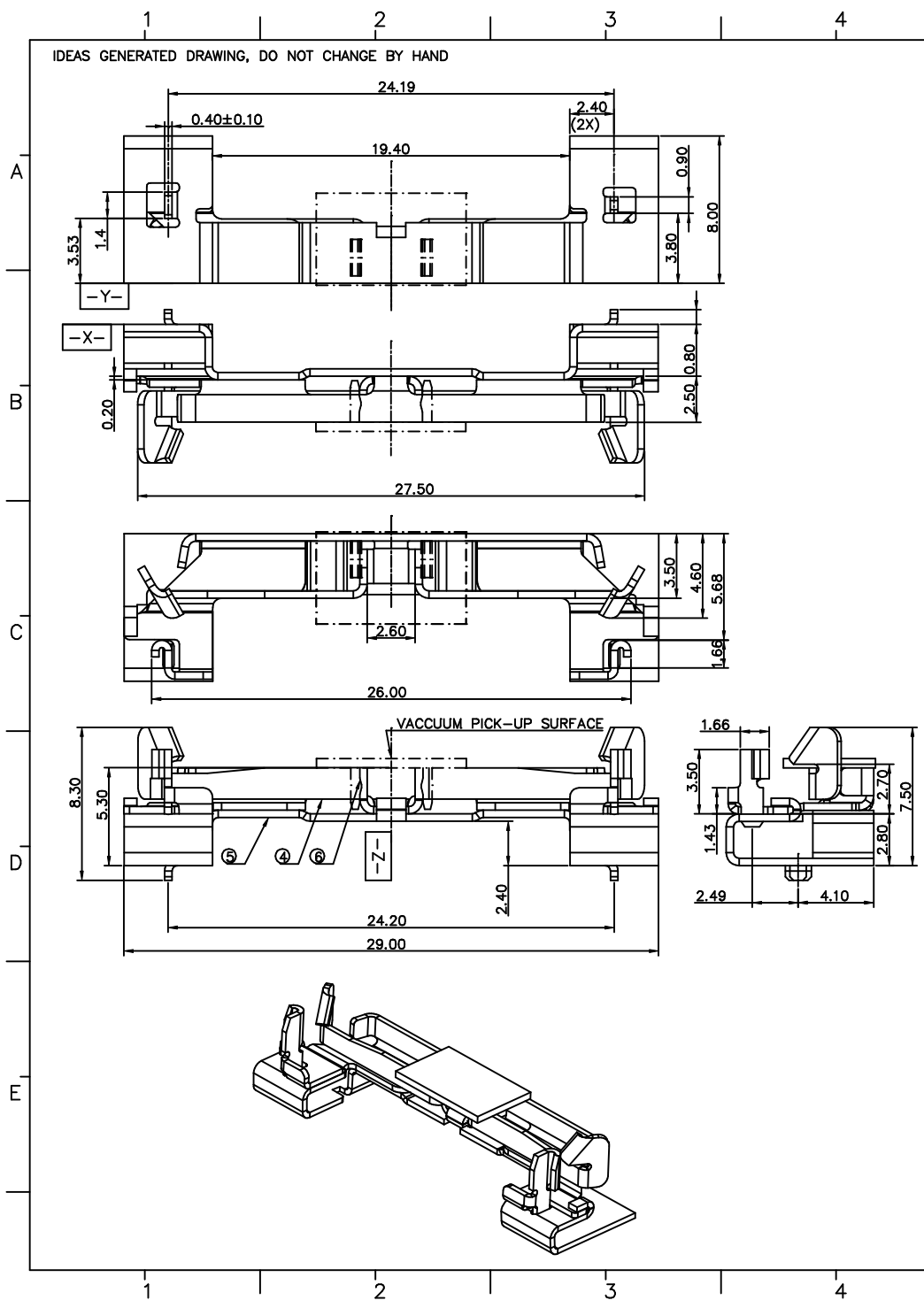

SPECIFICATIONS:

1. ELECTRICAL CHARACTERISTICS:
 - 1-1 CURRENT RATING: 0.75 A MAX per power contact.
 - 1-2 VOLTAGE RATING: 50 VAC per contact.
 - 1-3 LOW LEVEL CONTACT RESISTANCE: 55mΩ max. initial, ΔR =20mΩ max.
 - 1-4 INSULATION RESISTANCE: 500MΩ min. at 500 V DC.
 - 1-5 DIELECTRIC WITHSTANDING VOLTAGE: 300 V AC (RMS).
 - 1-6 INSERTION LOSS: f ≤1.25 GHz: ≤1dB; 1.25 <f≤3.75 GHz: ≤1.6x(f-1.25)+1dB
 - 1-7 RETURN LOSS: f ≤1.3GHz: ≤-12dB; 1.3<f≤2GHz: ≤-7dB; 2<f≤3.75GHz: ≤-4dB
 - 1-8 CROSSTALK NEXT: f≤1.25GHz: ≤-32dB; 1.25<f≤3.75GHz: ≤-(32-2.4x(f-1.25)) dB
 - 1-9 TEMPERATURE RISE VERSUS CURRENT: <30°C at rated current per EIA-364-70A, method 2.
2. MECHANICAL CHARACTERISTICS:
 - 2-1 DURABILITY: 50 mating/unmating cycles.
 - 2-2 MATING/UNMATING FORCE: 2.3 kgf max. per connector.
3. ENVIRONMENTAL CHARACTERISTICS:
 - 3-1 USEFUL FIELD LIFE: 5 years.
 - 3-2 OPERATING TEMPERATURE: -40°C TO +80°C.
 - 3-3 TEMPERATURE LIFE: Subject mated samples at 105±2°C for 120 hours per EIA-364-17, method A.
 - 3-4 THERMAL SHOCK: Subject mated samples to 10 cycles between -55 to 85°C per EIA-364-32C, condition I.
 - 3-5 CYCLIC TEMPERATURE & HUMIDITY: Subject mated samples to 24 cycles between 25°C at 80% RH to 65°C at 50% RH per EIA-364-31B.
 - 3-6 VIBRATION: Subject mated samples to 20 to 500 Hz, 3.1 g RMS random excitation of 15 min. in each of the 3 axes and no discontinuity >1μs is found per EIA-364-28D, test condition VII, test condition letter D.
 - 3-7 MECHANICAL SHOCK: Subject mated samples to 50% half-sine excitation of 11 ms duration and no discontinuity >1μs is found per per EIA-364-27B, condition A.
 - 3-8 MIXED FLOWING GAS: Subject mated samples for 7 days per EIA-364-65, class IIA.
 - 3-9 THERMAL DISTURBANCE: Subject mated samples to 10 cycles between 15 to 85°C.
4. PLEASE CONTACT FOXCONN SALES REPRESENTATIVE TO VERIFY PRODUCT DETAILS & AVAILABILITY.

⑥	CAP	1	THERMOPLASTIC	UL94V-0, IVORY COLOR(IN ORDER TO PICK-UP,TAKE AWAY AFTER ASSEMBLY)
⑤	CLIP(2)	1	STAINLESS STEEL	Pd PLATING OVER SOLDER PAD AREA
④	CLIP(1)	1	STAINLESS STEEL	NO PLATING
③	BOARD LOCK	2	COPPER ALLOY	PURE TIN OVER ALL
②	CONTACT	52	PHOSPHOR BRONZE	NICKEL UNDER PLATING GOLD PLATING AT CONTACT AREA
①	HOUSING	1	THERMOPLASTIC	UL94V-0, IVORY COLOR
ITEM	DESCRIPTION	Q'TY	MATERIAL	TREATMENT

x.± 0.30	x'±	UNITS	mm	NAME(INTENDED USE)	FOXCONN HON HAI PRECISION IND. CO.,LTD. TAIPEI, TAIWAN, R.O.C.
.x± 0.25	.x'±	MAT'L		MINI PCI EXPRESS Connector	
.xx± 0.15	.xx'±	FINISH		PART NO.(INTENDED USE)	TITLE:
.xxx±	.xxx'±	Q'TY		ASOB22*-S68*-**	CUSTOMER DRAWING
THESE DRAWINGS AND SPECIFICATIONS ARE THE PROPERTY OF HON HAI PRECISION IND. CO., LTD. AND SHALL NOT BE REPRODUCED, COPIED OR USED IN ANY MANNER WITHOUT THE PRIOR WRITTEN CONSENT OF HON HAI PRECISION IND. CO., LTD.				APPD:	DWG NO.:
				Bruce Wu 4/23'06	317-0000-1228
				CHKD:	SCALE
				Herry Yang 4/23'06	SHEET
				DR: Recharh.XIAO 4/21'06	REV.
					N/A
					2/6
					A

IDEAS GENERATED DRAWING, DO NOT CHANGE BY HAND

REV.	ECN.	NO.	APPD.

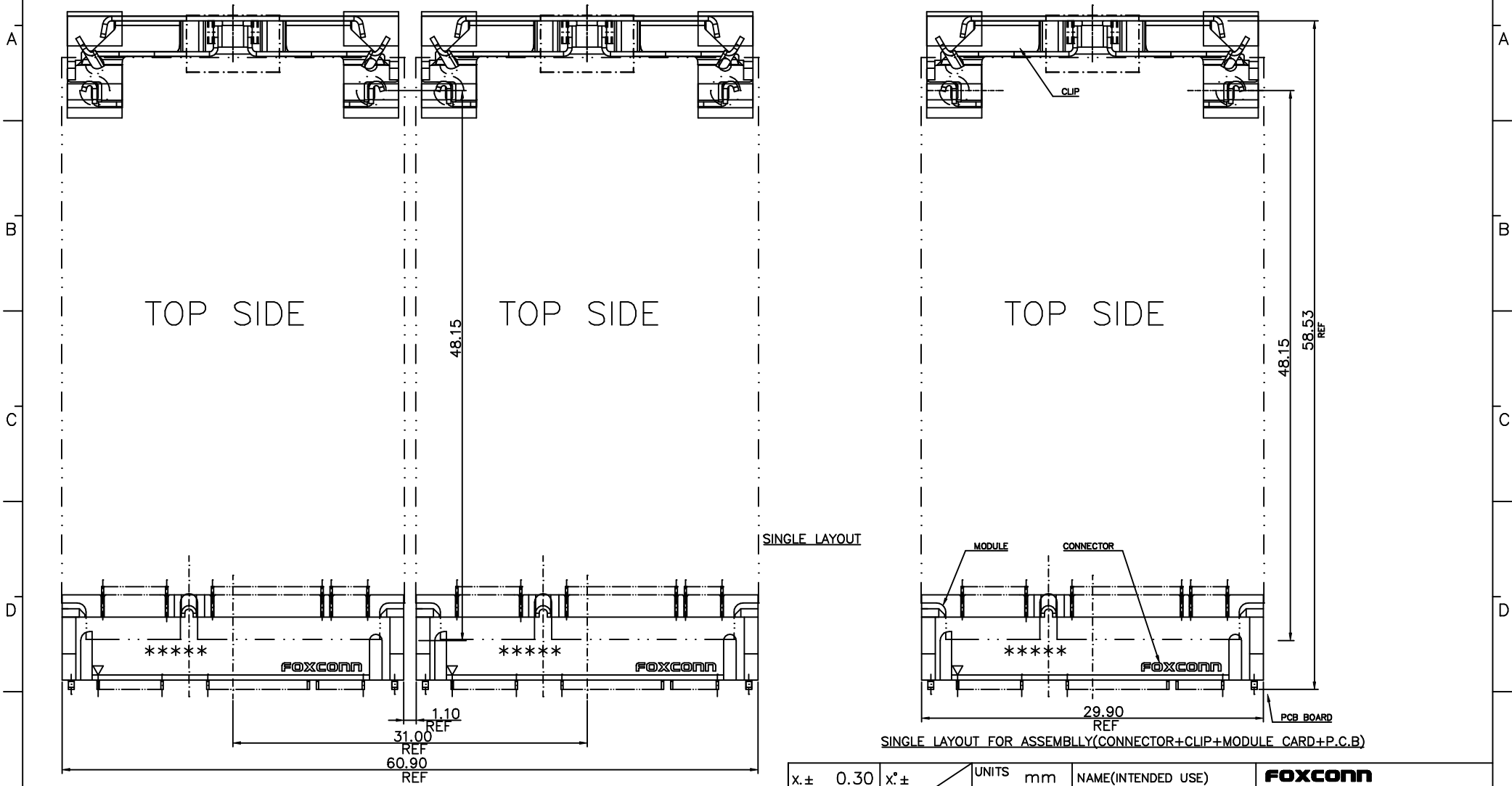

x.± 0.30	x'.±	UNITS mm	NAME(INTENDED USE)	FOXCONN HON HAI PRECISION IND. CO.,LTD. TAIPEI, TAIWAN, R.O.C.
.x± 0.25	.x'±		MINI PCI EXPRESS Connector	
.xx± 0.15	.xx'±	MAT'L	PART NO.(INTENDED USE)	TITLE:
.xxx±	.xxx'±		ASOB22*-S68*-**	CUSTOMER DRAWING
		FINISH	APPD:	DWG NO.:
				Bruce Wu 4/23'06
		Q'TY	CHKD:	SCALE SHEET REV.
			DR: Rechar.XIAO 4/21'06	N/A 3/6 A

THESE DRAWINGS AND SPECIFICATIONS ARE THE PROPERTY OF HON HAI PRECISION IND. CO., LTD. AND SHALL NOT BE REPRODUCED, COPIED OR USED IN ANY MANNER WITHOUT THE PRIOR WRITTEN CONSENT OF HON HAI PRECISION IND. CO., LTD.

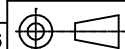

IDEAS GENERATED DRAWING, DO NOT CHANGE BY HAND

REV.	ECN.	NO.	APPD.

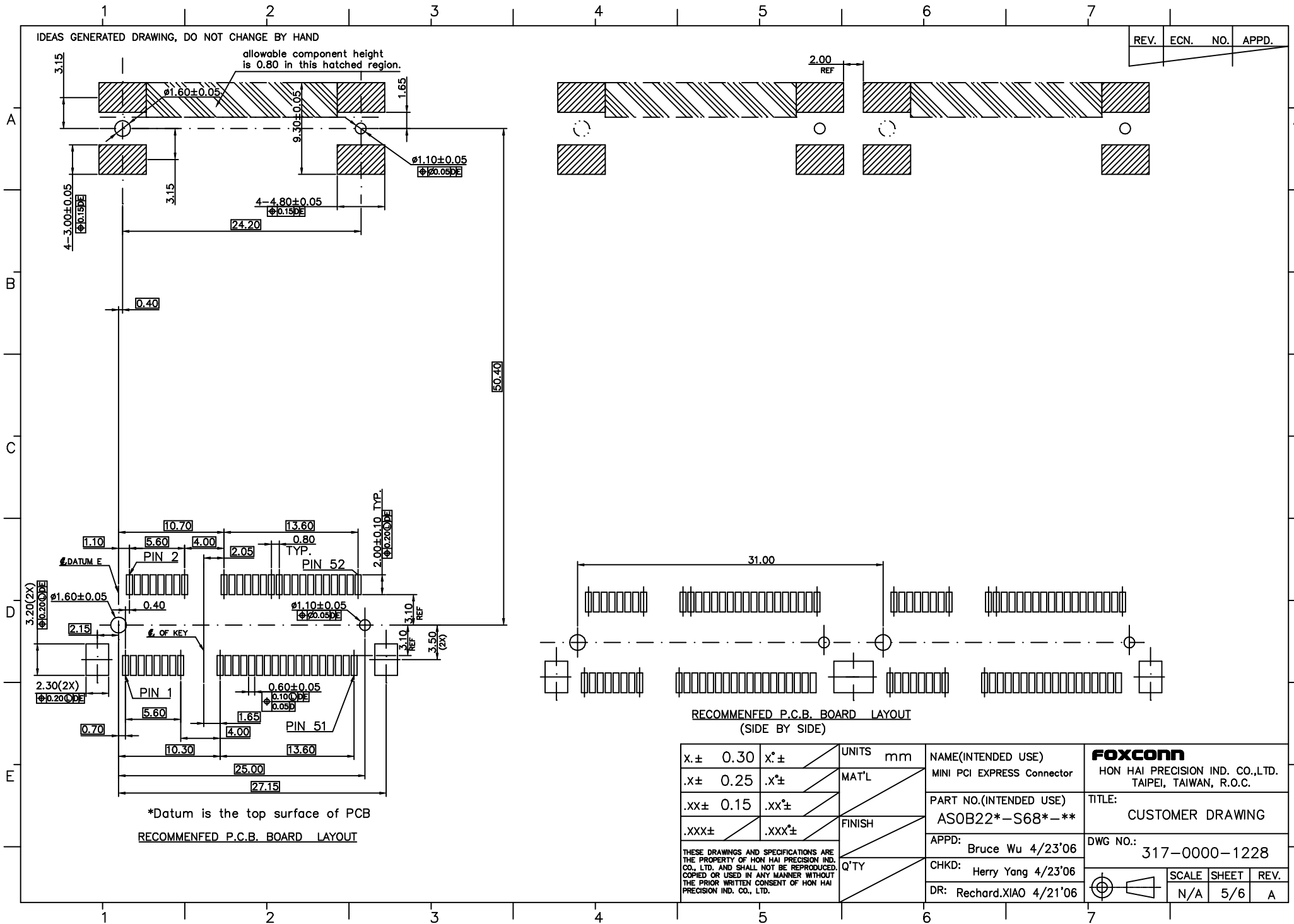

*Datum is the top surface of PCB
 RECOMMENFD P.C.B. BOARD LAYOUT

RECOMMENFD P.C.B. BOARD LAYOUT
 (SIDE BY SIDE)

x.± 0.30	x°.±	UNITS	mm
.x± 0.25	.x°.±		MAT'L
.xx± 0.15	.xx°.±	FINISH	
.xxx±	.xxx°.±		Q'TY

NAME(INTENDED USE)	MINI PCI EXPRESS Connector
PART NO.(INTENDED USE)	AS0B22*-S68*-**
APPD:	Bruce Wu 4/23'06
CHKD:	Herry Yang 4/23'06
DR:	Rechard.XIAO 4/21'06

FOXCONN	HON HAI PRECISION IND. CO.,LTD.	TAIPEI, TAIWAN, R.O.C.
TITLE:	CUSTOMER DRAWING	
DWG NO.:	317-0000-1228	
SCALE	SHEET	REV.
N/A	5/6	A

THESE DRAWINGS AND SPECIFICATIONS ARE THE PROPERTY OF HON HAI PRECISION IND. CO., LTD. AND SHALL NOT BE REPRODUCED, COPIED OR USED IN ANY MANNER WITHOUT THE PRIOR WRITTEN CONSENT OF HON HAI PRECISION IND. CO., LTD.