

K-no.: 26077

6 A Current Sensor for 5V- Supply Voltage

 For electronic current measurement:
 DC, AC, pulsed, mixed ..., with a galvanic
 isolation between primary circuit
 (high power) and secondary circuit
 (electronic circuit)

Date: 05.02.2014

Customer: Standard type

Customers Part no.:

Page 1 of 2

Description

- Closed loop (compensation)
- Current Sensor with magnetic field probe
- Printed circuit board mounting
- Casing and materials UL-listed

Characteristics

- Excellent accuracy
- Very low offset current
- Very low temperature dependency and offset current drift
- Very low hysteresis of offset current
- Short response time
- Wide frequency bandwidth
- Compact design
- Reduced offset ripple

Applications

Mainly used for stationary operation in industrial applications:

- AC variable speed drives and servo motor drives
- Static converters for DC motor drives
- Battery supplied applications
- Switched Mode Power Supplies (SMPS)
- Power Supplies for welding applications
- Uninterruptible Power Supplies (UPS)

Electrical data – Ratings

| | | | |
|-----------|--|--|---|
| I_{PN} | Primary nominal r.m.s. current | 6 | A |
| V_{out} | Output voltage @ I_P | $V_{Ref} \pm (0.625 \cdot I_P / I_{PN})$ | V |
| V_{out} | Output voltage @ $I_P=0, T_A=25^\circ C$ | $V_{Ref} \pm 0.0056$ | V |
| V_{Ref} | External Reference voltage range | 0...4 | V |
| | Internal Reference voltage | 2.5 ± 0.005 | V |
| K_N | Turns ratio | 1...4 : 2000 | |

Accuracy – Dynamic performance data

| | | min. | typ. | max. | Unit |
|-----------------------------------|--|----------|------|------|--------|
| $I_{P,max}$ | Max. measuring range | ±20 | | | |
| X | Accuracy @ $I_{PN}, T_A=25^\circ C$ | | | 0.7 | % |
| ϵ_L | Linearity | | | 0.1 | % |
| $V_{out} - V_{Ref}$ | Offset voltage @ $I_P=0, T_A=25^\circ C$ | | | ±5.3 | mV |
| $\Delta V_o / V_{Ref} / \Delta T$ | Temperature drift of V_{out} @ $I_P=0, V_{Ref}=2,5V, T_A=-40...85^\circ C$ | 6 | | 30 | ppm/°C |
| t_r | Response time @ 90% von I_{PN} | | 300 | | ns |
| $\Delta t (I_{P,max})$ | Delay time at $di/dt = 100 A/\mu s$ | | 200 | | ns |
| f | Frequency bandwidth | DC...200 | | | kHz |

General data

| | | min. | typ. | max. | Unit |
|-------|-------------------------------|------|------|------|------|
| T_A | Ambient operating temperature | -40 | | +85 | °C |
| T_S | Ambient storage temperature | -40 | | +105 | °C |
| m | Mass | | 12 | | g |
| V_C | Supply voltage | 4.75 | 5 | 5.25 | V |
| I_C | Current consumption | | 15 | | mA |

 Constructed and manufactured and tested in accordance with EN 61800-5-1 (Pin 1 – 4 to Pin 5 – 12)
 Reinforced insulation, Insulation material group 1, Pollution degree 2

| | | | | | |
|-------------|--|------------|--|------|----|
| S_{clear} | Clearance (component without solder pad) | 9.6 | | | mm |
| S_{creep} | Creepage (component without solder pad) | 10.6 | | | mm |
| V_{sys} | System voltage overvoltage category 3 | RMS | | 600 | V |
| V_{work} | Working voltage | RMS | | 1060 | V |
| U_{PD} | Rated discharge voltage | peak value | | 1320 | V |

 Note: "According UL 508: Max. potential difference = 600 V_{AC}"

| Date | Name | Issue | Amendment |
|----------|------|-------|---|
| 05.02.14 | Ga. | 83 | Marking changed acc to UL-specification. 4646X763-82 → 4646-X763-83. CN-924 |
| 08.07.13 | Ga. | 82 | Typo: page 2, primary current RMS changed from 2A to 1.5A. lapidary change. |

| | | | |
|-----------------------|-----------------------|---------------------|------------------------|
| Hrsg.: KB-E editor | Bearb: Le designer | KB-PM: Ga. check | freig.: HS released |
|-----------------------|-----------------------|---------------------|------------------------|

K-no.: 26077

6 A Current Sensor for 5V- Supply Voltage

For electronic current measurement:
DC, AC, pulsed, mixed ..., with a galvanic
isolation between primary circuit
(high power) and secondary circuit
(electronic circuit)

Date: 05.02.2014

Customer: Standard type

Customers Part no.:

Page 2 of 2

Mechanical outline (mm):

General tolerances DIN ISO 2768-c

Connections:

1...4: 0,46*0,46 mm
5..12: Ø 1 mm

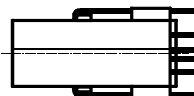
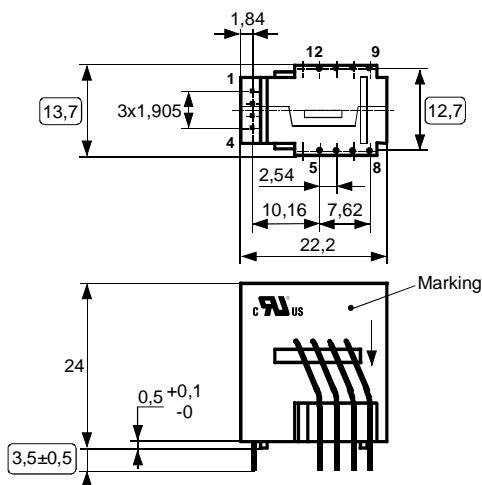

○ test dimension

Tolerances grid distance ±0,25mm

DC= Date Code
F = Factory

Marking:

VAC UL-sign
4646-X763-83
F DC

Schematic diagram

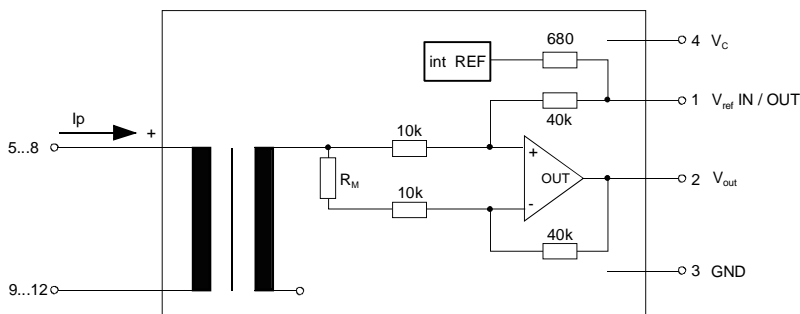

Possibilities of wiring (@ TA = 85°C)

| primary windings | primary current RMS | primary current maximal | output voltage RMS | turns ratio | primary resistance | wiring |
|------------------|---------------------|-------------------------|---|----------------|---------------------|--------|
| N _p | I _p [A] | I _{p,max} [A] | V _{out} (I _{pN}) [V] | K _N | R _p [mΩ] | |
| 1 | 6 | ±20 | 2.5±0.625 | 1:2000 | 0.25 | |
| 2 | 3 | ±10 | 2.5±0.625 | 2:2000 | 1.0 | |
| 4 | 1.5 | ±6,7 | 2.5±0.625 | 4:2000 | 4 | |

Operating temperature of the current sensor and the primary conductor must not exceed 105°C.

Additional information is obtainable on request.

This specification is no declaration of warranty acc. BGB §443 dar.

Hrsg.: KB-E
editor

Bearb.: Le
designer

KB-PM: Ga.
check

freig.: HS
released

K-No.: 26077

6 A Current Sensor for 5V-Supply Voltage

 For the electronic measurement of currents:
 DC, AC, pulsed, mixed ..., with a galvanic
 isolation between the primary circuit
 (high power) and the secondary circuit

Date: 05.02.2014

Customer:
Customers Part No.:
Page 1 **of** 2

Electrical Data

| | | min. | typ. | max. | Unit |
|--|--|------|--------------------------------------|------|------------|
| V_{Ctot} | Maximum supply voltage (without function) | | | 7 | V |
| I_C | Supply Current with primary current | | 15mA + $I_p \cdot K_N + V_{out}/R_L$ | | mA |
| $I_{out,SC}$ | Short circuit output current | | ± 20 | | mA |
| R_P | Resistance / primary winding @ $T_A=25^\circ C$ | | 1 | | m Ω |
| R_S | Secondary coil resistance @ $T_A=85^\circ C$ | | | 67 | Ω |
| $R_{i,Ref}$ | Internal resistance of Reference input | | 670 | | Ω |
| $R_{is}(V_{out})$ | Output resistance of V_{out} | | | 1 | Ω |
| R_L | External recommended resistance of V_{out} | 1 | | | k Ω |
| C_L | External recommended capacitance of V_{out} | | | 500 | pF |
| $\Delta X_{Ti}/\Delta T$ | Temperature drift of X @ $T_A = -40 \dots +85^\circ C$ | | | 40 | ppm/K |
| $\Delta V_0 = \Delta(V_{out} - V_{Ref})$ | Sum of any offset drift including: | | 5 | 15 | mV |
| V_{0t} | Longtermdrift of V_0 | | 3 | | mV |
| V_{0T} | Temperature drift von V_0 @ $T_A = -40 \dots +85^\circ C$ | | 3 | | mV |
| V_{0H} | Hysteresis of V_{out} @ $I_p=0$ (after an overload of $10 \times I_{PN}$) | | | 7.5 | mV |
| $\Delta V_0/\Delta V_C$ | Supply voltage rejection ratio | | | 1 | mV/V |
| V_{oss} | Offsetripple (with 1 MHz- filter first order) | | | 55 | mV |
| V_{oss} | Offsetripple (with 100 kHz- filter first order) | | 9 | 15 | mV |
| V_{oss} | Offsetripple (with 20 kHz- filter first order) | | 2.5 | 4 | mV |
| C_k | Maximum possible coupling capacity (primary – secondary) | | 5 | 10 | pF |
| | Mechanical stress according to M3209/3 | | | 30g | |
| | Settings: 10 – 2000 Hz, 1 min/Oktave, 2 hours | | | | |

Inspection (Measurement after temperature balance of the samples at room temperature; SC = significant characteristic)

| | | | | | |
|--------------------------|------------|----------|---|-----------------|---------|
| $V_{out}(I_p=I_{PN})$ | (V) | M3011/6: | Output voltage vs. external reference ($I_p=6A$, 40-80Hz) | $625 \pm 0,7\%$ | mV (SC) |
| $V_{out}-V_{Ref}(I_p=0)$ | (V) | M3226: | Offset voltage | ± 5.3 | mV |
| V_d | (V) | M3014: | Test voltage, rms, 1 s pin 1 – 4 vs. pin 5 – 12 | 1.8 | kV |
| V_e | (AQL 1/S4) | | Partial discharge voltage acc.M3024 (RMS) with V_{vor} (RMS) | 1400 1750 | V V |

Type Testing (Pin 1 - 4 to Pin 5 - 12)

| | | | | | |
|-------|--|--|--|--------------|--------|
| V_W | | | HV transient test according to M3064 (1,2 μs / 50 μs -wave form) | 8 | kV |
| V_d | | | Testing voltage to M3014 | (5 s) | 3.6 kV |
| V_e | | | Partial discharge voltage acc.M3024 (RMS) with V_{vor} (RMS) | 1400 1750 | V V |

Applicable documents

 Current direction: A positive output current appears at point I_s , by primary current in direction of the arrow.
 Enclosures according to IEC529: IP50.

Further standards UL 508 file E317483, category NMTR2 / NMTR8

| Datum | Name | Index | Amendment |
|----------|------|-------|--------------------------------|
| 05.02.14 | Ga. | 83 | Date updated. |
| 08.07.13 | Ga. | 82 | Date updated. Lapidary change. |

| | | | |
|-----------------------|-------------------------|----------------------|------------------------|
| Hrsg.: KB-E editor | Bearb.: Le. designer | KB-PM: KRe. check | freig.: HS released |
|-----------------------|-------------------------|----------------------|------------------------|

K-No.: 26077

6 A Current Sensor for 5V-Supply Voltage

 For the electronic measurement of currents:
 DC, AC, pulsed, mixed ..., with a galvanic
 isolation between the primary circuit
 (high power) and the secondary circuit

Date: 05.02.2014

Customer:

Customers Part No.:

Page 2 of 2

Explanation of several of the terms used in the tablets (in alphabetical order)

t_r : Response time (describe the dynamic performance for the specified measurement range), measured as delay time at $I_P = 0,9 \cdot I_{PN}$ between a rectangular current and the output voltage $V_{out}(I_P)$

$\Delta t(I_{Pmax})$: Delay time (describe the dynamic performance for the rapid current pulse rate e.g short circuit current) measured between I_{Pmax} and the output voltage $V_{out}(I_{Pmax})$ with a primary current rise of $di_P/dt \geq 100 A/\mu s$.

V_o : Offset voltage between V_{out} and the rated reference voltage of $V_{ref} = 2,5V$.
 $V_o = V_{out}(0) - 2,5V$

U_{PD} Rated discharge voltage (recurring peak voltage separated by the insulation) proved with a sinusoidal voltage V_e
 $U_{PD} = \sqrt{2} \cdot V_e / 1,5$

V_{vor} Defined voltage is the RMS value of a sinusoidal voltage with peak value of $1,875 \cdot U_{PD}$ required for partial discharge test in IEC 61800-5-1
 $V_{vor} = 1,875 \cdot U_{PD} / \sqrt{2}$

V_{sys} System voltage RMS value of rated voltage according to IEC 61800-5-1

V_{work} Working voltage voltage according to IEC 61800-5-1 which occurs by design in a circuit or across insulation

V_{oH} : Zero variation of V_o after overloading with a DC of tenfold the rated value

V_{oT} : Long term drift of V_o after 100 temperature cycles in the range -40 bis 85 °C.

X : Permissible measurement error in the final inspection at RT, defined by

$$X = 100 \cdot \left| \frac{V_{out}(I_{PN}) - V_{out}(0)}{0,625V} - 1 \right| \%$$

$X_{ges}(I_{PN})$: Permissible measurement error including any drifts over the temperature range by the current measurement I_{PN}

$$X_{ges} = 100 \cdot \left| \frac{V_{out}(I_{PN}) - 2,5V}{0,625V} - 1 \right| \% \quad \text{or} \quad X_{ges} = 100 \cdot \left| \frac{V_{out}(I_{PN}) - V_{ref}}{0,625V} - 1 \right| \%$$

ϵ_L : Linearity fault defined by $\epsilon_L = 100 \cdot \left| \frac{I_P}{I_{PN}} - \frac{V_{out}(I_P) - V_{out}(0)}{V_{out}(I_{PN}) - V_{out}(0)} \right| \%$

This "Additional information" is no declaration of warranty according BGB §443.

 Hrsg.: KB-E
 editor

 Bearb.: Le.
 designer

 KB-PM: KRe.
 check

 freig.: HS
 released