

THIS DRAWING IS UNPUBLISHED. RELEASED FOR PUBLICATION  
 © COPYRIGHT - By - ALL RIGHTS RESERVED.

LDC		DIST		REVISIONS			
P	LTR	DESCRIPTION	DATE	DWN	APVD		
-	-	F	REV PER ECO 14-016957	2-2-07	CT	DE	

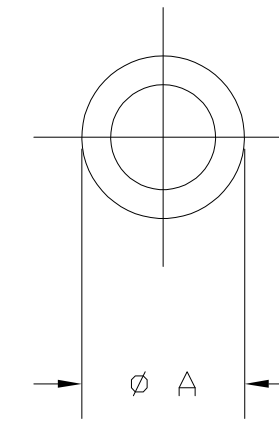
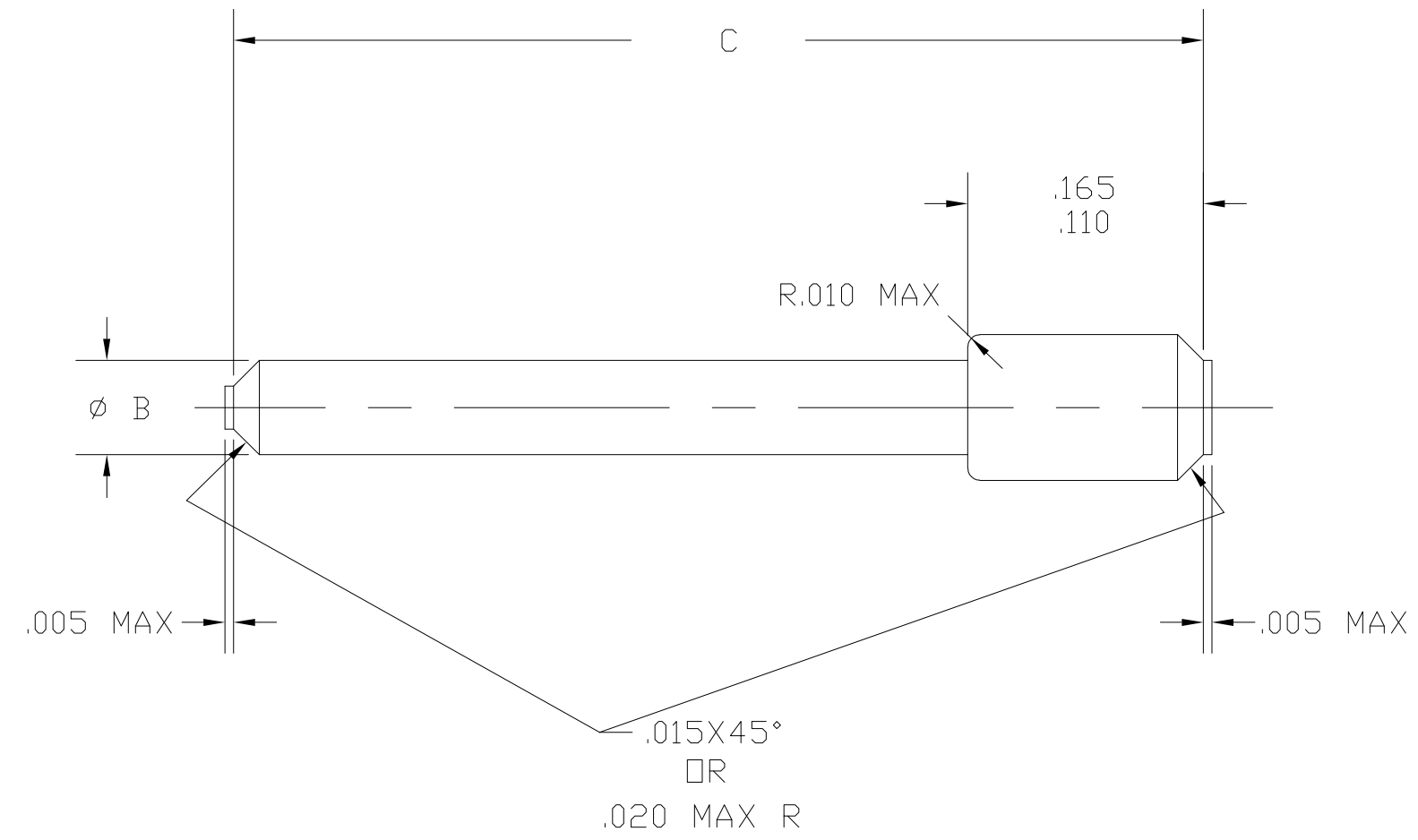

.469±.031	.040±.005	.063±.005	BLACK	22HD	592104-4
.564±.020	.121±.010	.171±.005	YELLOW	12	592104-3
.564±.020	.083±.010	.133±.005	BLUE	16	592104-2
.564±.020	.055±.010	.085 <sup>+.015</sup> <sub>-.000</sub>	RED	20/22	592104-1
DIM. C	DIM. B	DIM. A	COLOR	SIZE	PART NO.

TABULATION CHART

THIS DRAWING IS A CONTROLLED DOCUMENT.		DWN	12MAY99	TE Connectivity	
DIMENSIONS: INCHES		CHK	5-11-99		
TOLERANCES UNLESS OTHERWISE SPECIFIED:		APVD	5-11-99		
0 PLC ± - 1 PLC ± - 2 PLC ± - 3 PLC ± .005 4 PLC ± - ANGLES ± -		NAME			
MATERIAL		PRODUCT SPEC			
TEFLON PER MS27488		FINISH		APPLICATION SPEC	
		WEIGHT		RESTRICTED TO	
		SCALE 10:1		SHEET 1 OF 1	
		CUSTOMER DRAWING		REV F	

592104