

# QUICK START GUIDE FOR DEMONSTRATION CIRCUIT 1025

## 800MA MONOLITHIC SYNCHRONOUS BUCK REGULATOR

LTC3560

### DESCRIPTION

Demonstration circuit 1025 is a step-down converter, using the LTC3560 monolithic synchronous buck regulator. The DC1025 has an input voltage range of 2.5V to 5.5V, and is capable of delivering up to 800 mA of output current. The output voltage of the DC1025 can be set as low as 0.6V, the reference voltage of the LTC3560. At low load currents, the DC1025 can operate in either noise sensitive applications, due to the capability of the LTC3560 to operate in pulse-skipping mode, or in high efficiency applications, because the LTC3560 can also operate in Burst-Mode. Of course, in continuous mode, or large load current applications, the DC1025 is a high efficiency

circuit - over 95% in some cases. The DC1025 consumes less than 30  $\mu$ A of quiescent current during sleep operation, and during shutdown, it consumes less than 1  $\mu$ A. Because of the high switching frequency of the LTC3560 - 2.25 MHz - the DC1025 uses low profile surface mount components. These features, plus the LTC3560 coming in a small 6-Lead ThinSot package, make the DC1025 an ideal circuit for use in battery-powered, hand-held applications.

**Design files for this circuit board are available. Call the LTC factory.**

LTC is a trademark of Linear Technology Corporation

**Table 1. Performance Summary ( $T_A = 25^\circ\text{C}$ )**

PARAMETER	CONDITIONS	VALUE
Minimum Input Voltage		2.5V
Maximum Input Voltage		5.5V
Run/Shutdown		GND = Shutdown
		$V_{IN} = \text{Run}$
Output Voltage $V_{OUT}$	$V_{IN} = 2.5\text{V to } 5.5\text{V}, I_{OUT} = 0\text{A to } 800\text{ mA}$	$1.2\text{V} \pm 4\%$ (1.152V – 1.248V)
		$1.5\text{V} \pm 4\%$ (1.44V - 1.56V)
		$1.8\text{V} \pm 4\%$ (1.728V – 1.872V)
Typical Output Ripple $V_{OUT}$	$V_{IN} = 3.3\text{V}, V_{OUT} = 1.8\text{V}, I_{OUT} = 800\text{ mA}$ (20 MHz BW)	< 20mV <sub>P-P</sub>
Operation Modes	Burst Mode - $V_{IN} = 3.3\text{V}, V_{OUT} = 1.8\text{V}$	<100 mA $\pm$ 20 mA
	Pulse-Skip - $V_{IN} = 3.3\text{V}, V_{OUT} = 1.8\text{V}$	<100 mA $\pm$ 20 mA
Nominal Switching Frequency		2.25 MHz

### QUICK START PROCEDURE

Demonstration Circuit 1025 is easy to set up to evaluate the performance of the LTC3560. For proper measurement equipment configuration, set up the circuit according to the diagram in **Figure 1**. Before proceeding to test, insert shunts into the OFF position of header JP1, which connects the RUN pin to ground (GND), and thus, shuts down the circuit, the pulse-skip position of header JP2, and the 1.8V output voltage header – JP5.

When measuring the input or output voltage ripple, care must be taken to avoid a long ground lead on the oscilloscope probe. Measure the input or output voltage ripple by touching the probe tip directly across the Vin or Vout and GND terminals. See **Figure 2** for proper scope probe measurement technique.

With the DC1025 set up according to the proper measurement and equipment in **Figure 1**, apply 3.3V at Vin (Do not hot-plug Vin or increase Vin over the rated maximum supply voltage of 5.5V, or the part may be damaged.). Measure Vout; it should read 0V. If desired, one can measure the shutdown supply current at this point. The supply current will be approximately 1 uA, or less, in shutdown.

Turn on the circuit by inserting the shunt in header JP1 into the ON position. The output voltage should be regulating. Measure Vout - it should measure 1.8V +/- 2% (1.764V to 1.836V).

Vary the input voltage from 2.5V to 5.5V and adjust the load current from 0 to 800 mA. Vout should read between 1.2V +/- 4% (1.728V to 1.872V).

Measure the output ripple voltage at any output current level; it usually will measure less than 30 mVAC.

Observe the voltage waveform at the switch node. Verify the switching frequency is between 1.8 MHz and 2.7 MHz ( $T = 0.555 \mu\text{s}$  and  $0.37 \mu\text{s}$ ), and that the switch node waveform is rectangular in shape.

Insert the JP1 shunt into the OFF position and move the 1.8V Vout JP5 shunt into any of the two remaining output voltage option headers: 1.2V or 1.5V. Just as in the 1.8Vout test, the output voltage should read Vout +/- 2% tolerance under static line and load conditions, and +/- 1% tolerance under dynamic line and load conditions (+/- 2% total).

When finished, turn off the circuit by inserting the shunt in header JP1 into the OFF position (connecting the RUN pin to ground).

# QUICK START GUIDE FOR DEMONSTRATION CIRCUIT 1025

## 800mA MONOLITHIC SYNCHRONOUS BUCK REGULATOR

Demonstration circuit 1025 is a step-down converter based on the LTC3560 monolithic synchronous buck regulator. The DC1025 is easy to set up and evaluate the performance of the LTC3560. Refer to Figure 1 for proper equipment set-up.

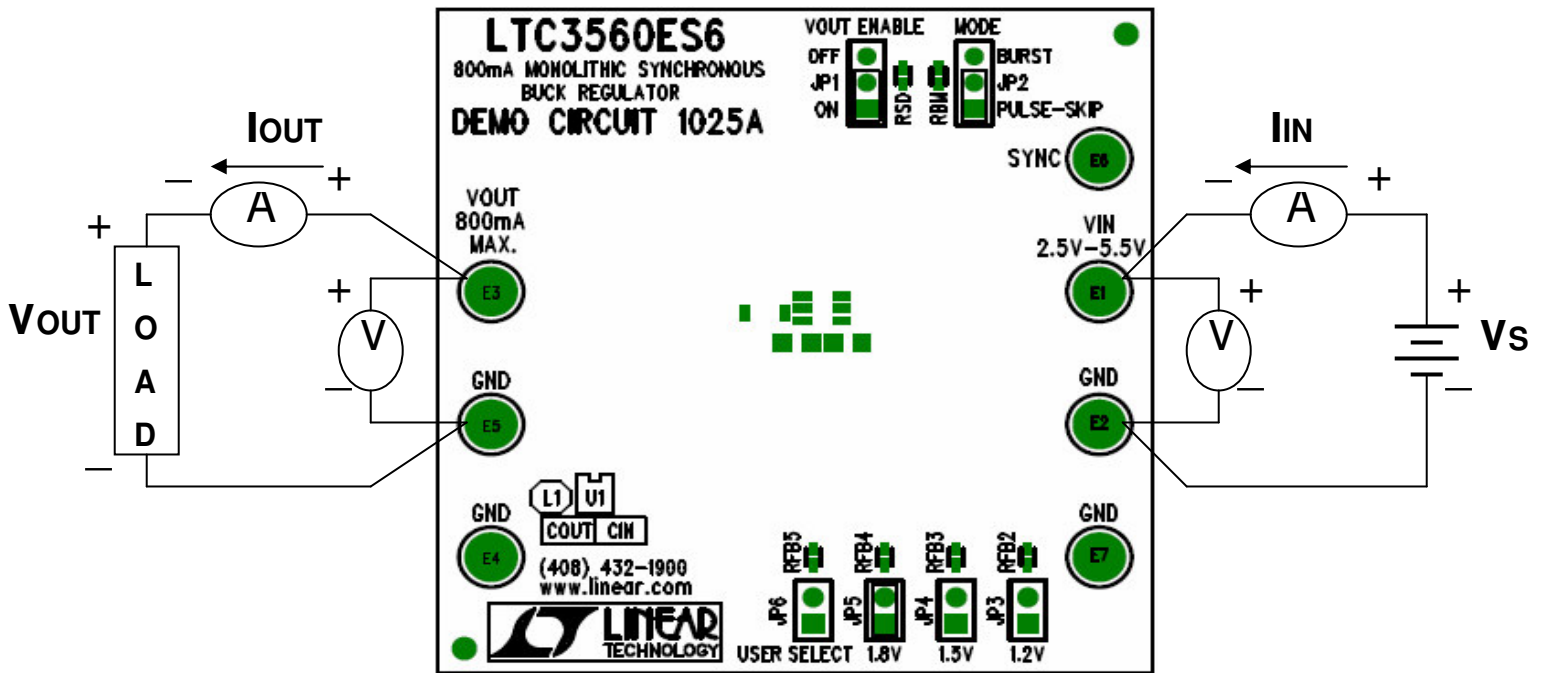

Figure 1. Proper Equipment Measurement Set-Up

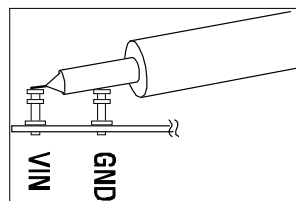
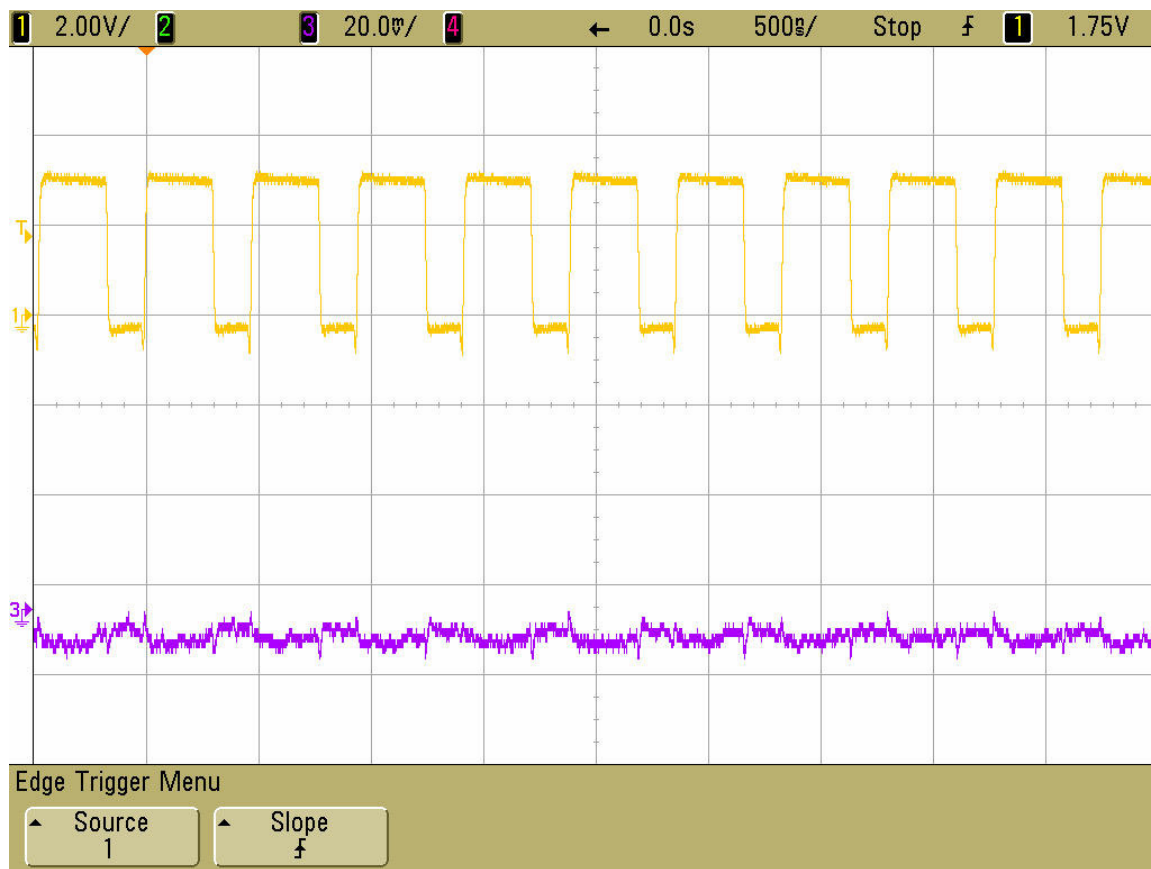

Figure 2. Measuring Input or Output Ripple

## Normal Switching Frequency & Output Ripple Voltage Waveforms



**Figure 3. Switch Waveform & Output Ripple Voltage**

$$V_{IN} = 3.3V, V_{OUT} = 1.8V, I_{OUT} = 800mA$$

Trace 1: Switch Voltage (2 V/div)

Trace 3: Output Ripple Voltage (20 mV/div AC)

## Load Step Response Waveform

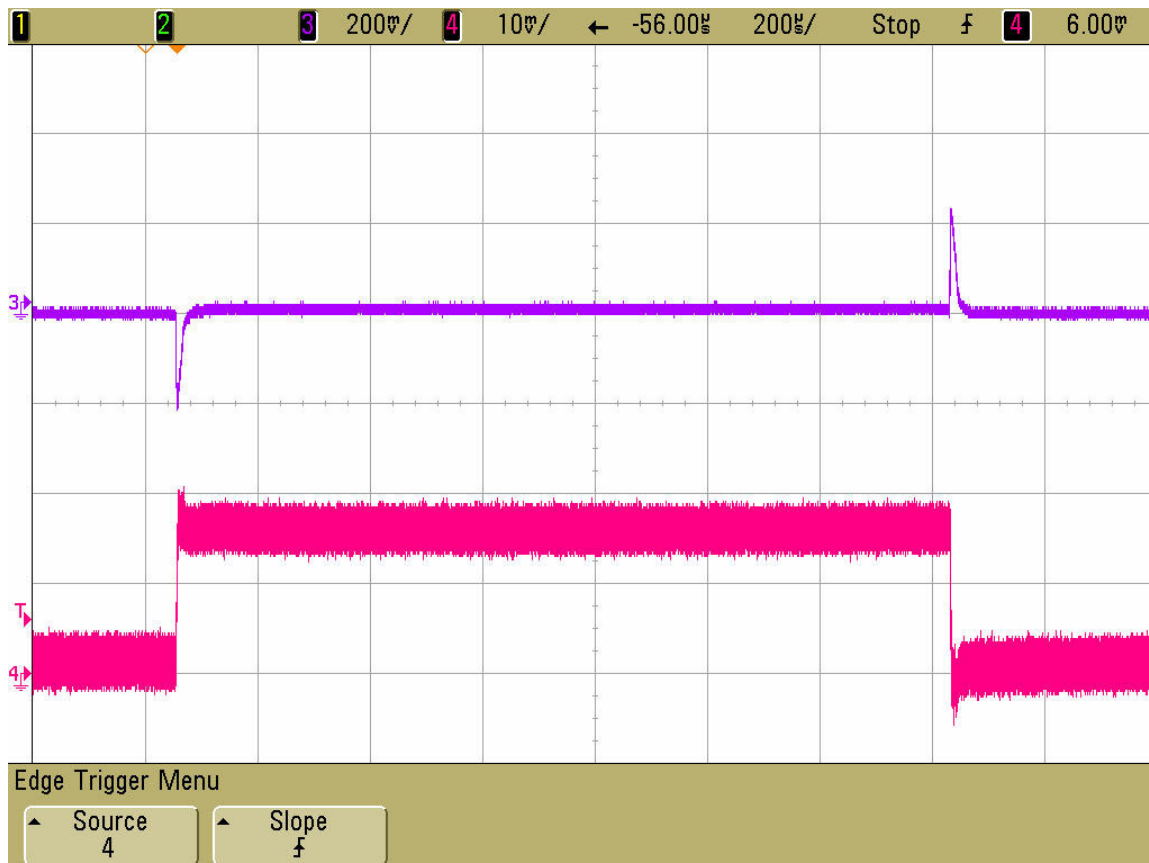

**Figure 4. Load Step Response**

$V_{IN} = 3.3V$ ,  $V_{OUT} = 1.8V$ , 720mA Load Step (80mA  $\leftrightarrow$  800mA)

Trace 3: Output Voltage (200mV/div AC)

Trace 4: Output Current (500 mA/div)

# QUICK START GUIDE FOR DEMONSTRATION CIRCUIT 1025

## 800mA MONOLITHIC SYNCHRONOUS BUCK REGULATOR

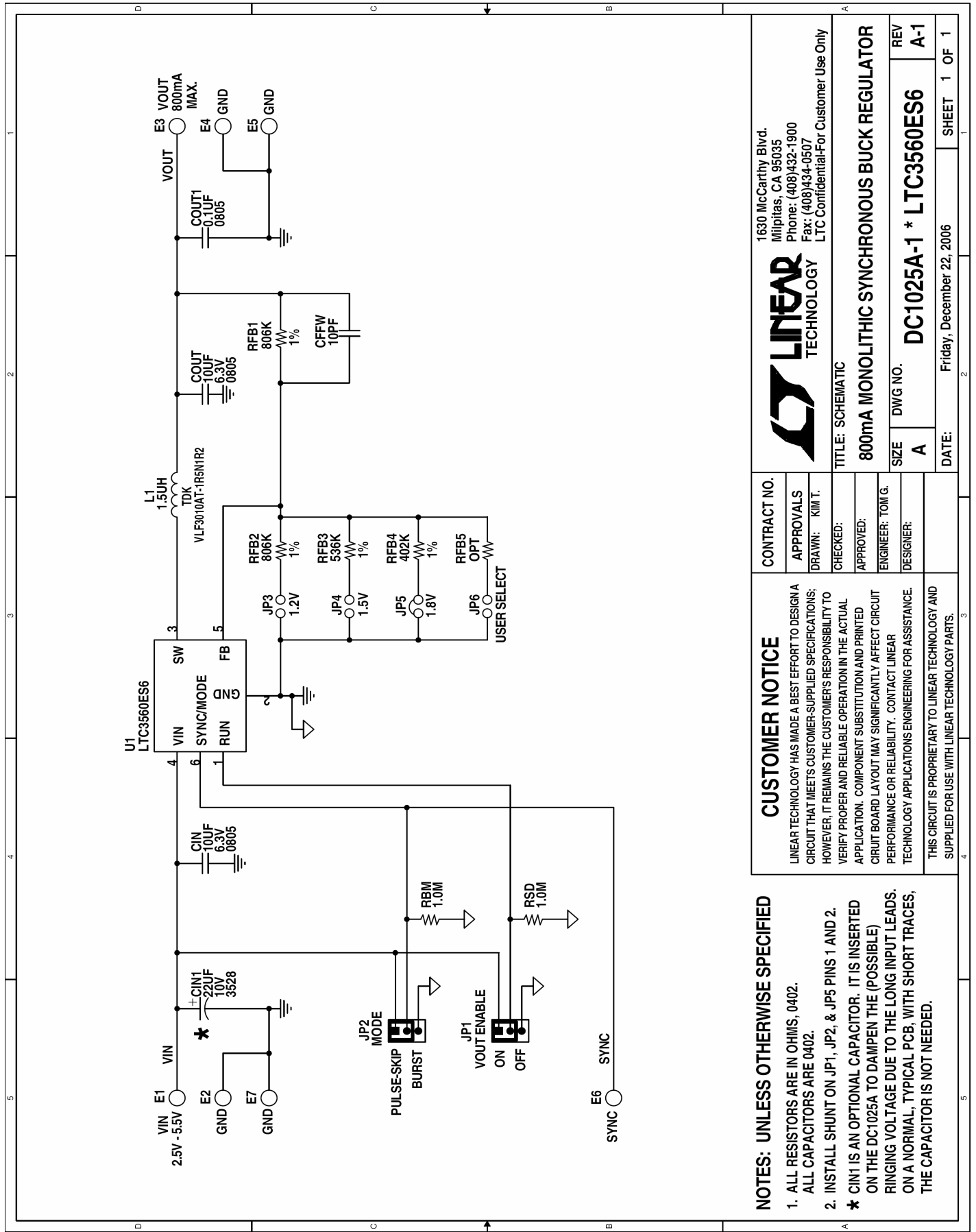

### NOTES: UNLESS OTHERWISE SPECIFIED

- ALL RESISTORS ARE IN OHMS, 0402.  
ALL CAPACITORS ARE 0402.
- INSTALL SHUNT ON JP1, JP2, & JP5 PINS 1 AND 2.
- \*** CIN1 IS AN OPTIONAL CAPACITOR. IT IS INSERTED ON THE DC1025A TO DAMPEN THE (POSSIBLE) RINGING VOLTAGE DUE TO THE LONG INPUT LEADS. ON A NORMAL, TYPICAL PCB, WITH SHORT TRACES, THE CAPACITOR IS NOT NEEDED.

### CUSTOMER NOTICE

LINEAR TECHNOLOGY HAS MADE A BEST EFFORT TO DESIGN A CIRCUIT THAT MEETS CUSTOMER-SUPPLIED SPECIFICATIONS; HOWEVER, IT REMAINS THE CUSTOMER'S RESPONSIBILITY TO VERIFY PROPER AND RELIABLE OPERATION IN THE ACTUAL APPLICATION. COMPONENT SUBSTITUTION AND PRINTED CIRCUIT BOARD LAYOUT MAY SIGNIFICANTLY AFFECT CIRCUIT PERFORMANCE OR RELIABILITY. CONTACT LINEAR TECHNOLOGY APPLICATIONS ENGINEERING FOR ASSISTANCE.

THIS CIRCUIT IS PROPRIETARY TO LINEAR TECHNOLOGY AND SUPPLIED FOR USE WITH LINEAR TECHNOLOGY PARTS.

### CONTRACT NO.

### APPROVALS

DRAWN: KIM T.

CHECKED:

APPROVED:

ENGINEER: TOM G.

DESIGNER:

**LINEAR**  
TECHNOLOGY

1630 McCarthy Blvd.  
Milpitas, CA 95035  
Phone: (408)432-1900  
Fax: (408)434-0607  
LTC Confidential-For Customer Use Only

TITLE: SCHEMATIC

800mA MONOLITHIC SYNCHRONOUS BUCK REGULATOR

SIZE DWG NO. REV  
**A** **DC1025A-1 \* LTC3560ES6** **A-1**

DATE: Friday, December 22, 2006 SHEET 1 OF 1