

THIS DRAWING IS UNPUBLISHED. RELEASED FOR PUBLICATION 20  
 © COPYRIGHT 20 BY - ALL RIGHTS RESERVED.

REVISIONS

P	LTR	DESCRIPTION	DATE	DWN	APVD
A		INITIAL RELEASE	19MAR2015	DL	CW
B		ECR-15-013292	24SEP2015	DL	CW

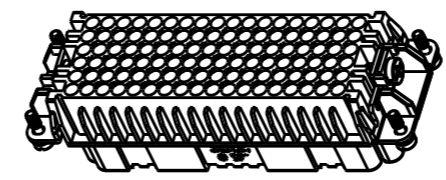
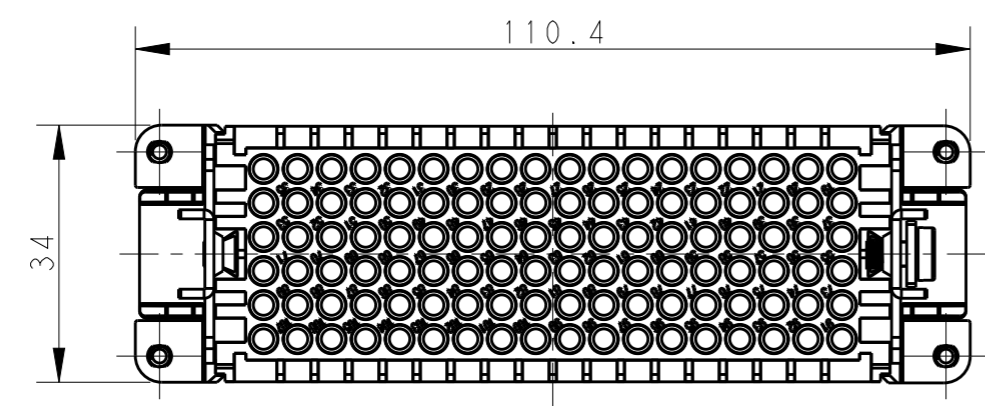

SCALE 1:2

M4 SCREW  
RECOMMENDED TIGHTENING TORQUE 1.2Nm  
 4 X M3 SCREW  
RECOMMENDED TIGHTENING TORQUE 0.5Nm

NOTES:

- TECHNICAL CHARACTERISTICS:  
 INSULATION MATERIAL: PC  
 RATED VOLTAGE: 250 V  
 RATED CURRENT: 10 A  
 INSULATION RESISTANCE:  $\geq 400M\Omega$   
 RATED IMPULSE VOLTAGE: 2.5 KV  
 POLLUTION DEGREE: 2  
 FLAMMABILITY: UL94V-0  
 MATING CYCLES: 500 CYCLES  
 OPERATION TEMPERATURE:  $-40+125^{\circ}C$   
 WIRE RANGE: 0.14-2.5 mm<sup>2</sup> (26-14 AWG)  
 CONTACT TYPE: CRIMP CONTACT
- CONTACT NEED TO BE ORDERED SEPARATELY.  
 (ORDER No. REFER TO DRAWING: T20200X20XX000)

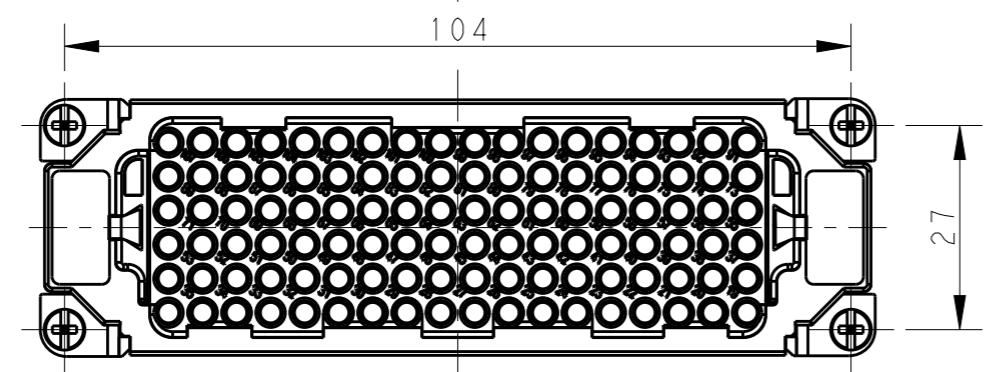
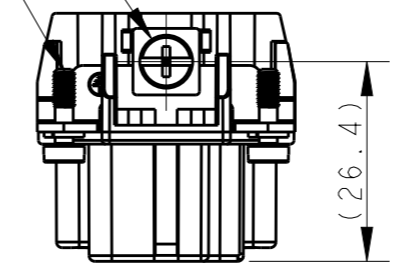
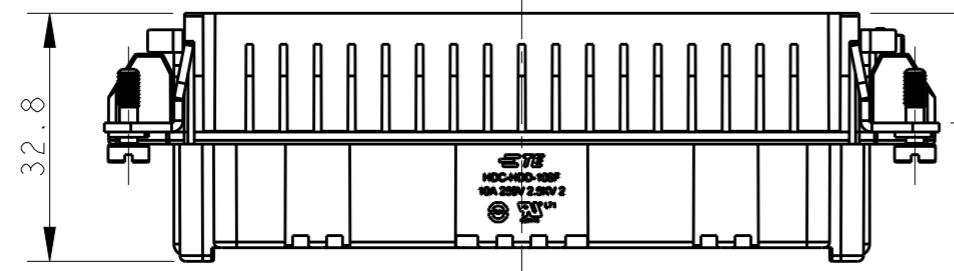
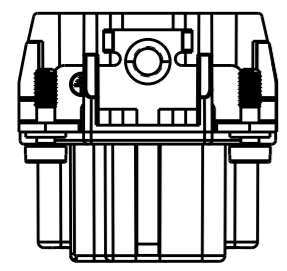

注释:

- 技术参数:  
 绝缘材料: PC  
 额定电压: 250V  
 额定电流: 10A  
 绝缘电阻:  $\geq 400M\Omega$   
 额定脉冲电压: 2.5 KV  
 污染等级: 2  
 阻燃等级: UL94V-0  
 插拔次数: 500次  
 工作温度:  $-40+125^{\circ}C$   
 接线范围: 0.14-2.5 mm<sup>2</sup> (26-14 AWG)  
 接线类型: 冷压接
- 端子需要单独订购。  
 (订货号参考图面: T20200X20XX000)

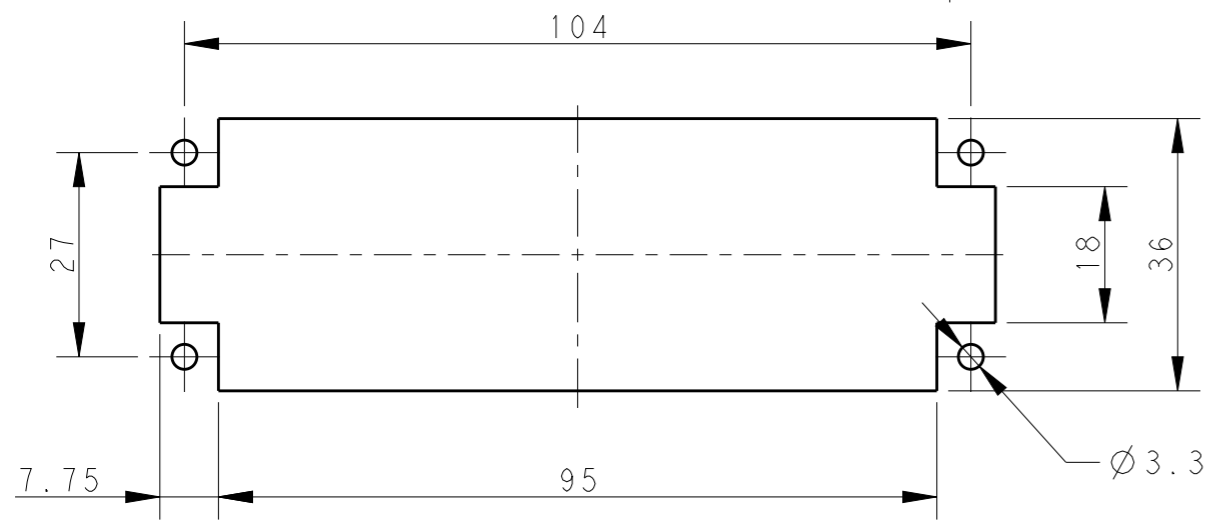

PANEL CUT OUT FOR INSERTS FOR USING WITHOUT HOODS/HOUSINGS

THIS DRAWING IS A CONTROLLED DOCUMENT.

DIMENSIONS:	TOLERANCES UNLESS OTHERWISE SPECIFIED:
mm	
	0 PLC ±-
	1 PLC ±-
	2 PLC ±-
	3 PLC ±-
	4 PLC ±-
	ANGLES ±-
MATERIAL	FINISH
-	-
-	-

DWN	DAVID LI	18MAR2015
CHK	CHRIS WANG	18MAR2015
APVD	XU XIANG	18MAR2015
PRODUCT SPEC	108-137043	
APPLICATION SPEC	114-137043	
WEIGHT	-	
CUSTOMER DRAWING		

HDD-108-F	T2031082201-000
DESCRIPTION	PART NUMBER



TE Connectivity

NAME		HDD-108-F	
SIZE	CAGE CODE	DRAWING NO	RESTRICTED TO
A3	-	©-T2031082201000	-
SCALE		SHEET	REV
1:1		1 OF 1	B