

DIMENSIONS					
POSITION	A ±0.10	B $\begin{smallmatrix} +0.15 \\ -0.05 \end{smallmatrix}$	C ±0.20	D ±0.23	E ±0.20
36	6	7.65	9.15	25.00	27.00
64	20	21.65	23.15	39.00	41.00
98	37	38.65	40.15	56.00	58.00
164	70	71.65	73.15	89.00	91.00

mat'l. code		N/A		surface 58		tolerance		projection		product family		EDGE CARD	
ltr		ecn no		dr		date		tolerances unless otherwise specified		title		PCI EXPRESS SMT TYPE GEN3 for SIOM	
A		T07-1031		S.Lin		03/28/07		.X ± 0.30		MM		5	
B		T07-1151		J.H		11/05/07		.XX ± 0.20		scale N/A		A	
C		ELX-DG-17423-1		ST		04/10/14		.XXX ± 0.10					
D		ELX-DG-17800-1		ST		05/28/14		dr Stone Li 05/28/15		FCI		sheet 1 of 4 size	
E		ELX-DG-21161-1		ST		05/28/15		engr Stone Li 05/28/15				10073228 A4	
								chr / 05/28/15					
								appd PeiMing Zheng 05/28/15				type CUSTOMER Drawing	
sheet index		revision sheet		E		E		E		E			
				1		2		3		4			

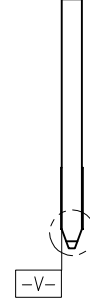

← I/O PANEL DIRECTION
PRIMARY (COMPONENT) SIDE

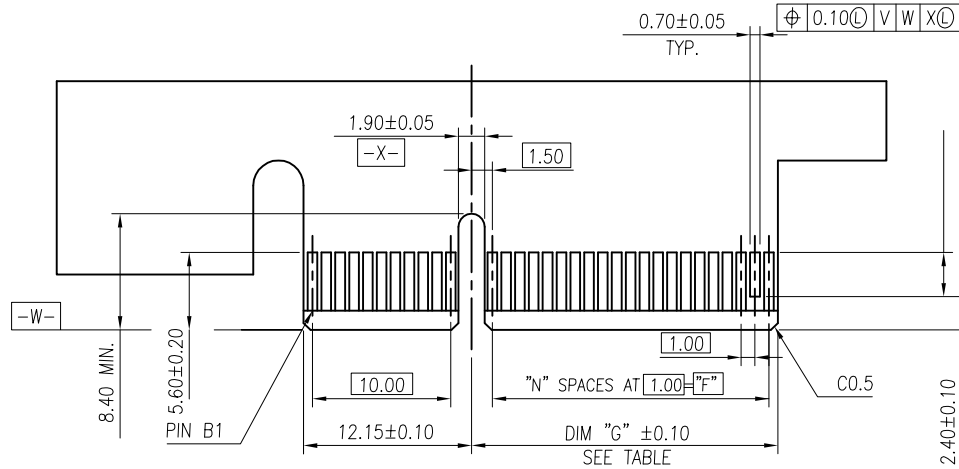
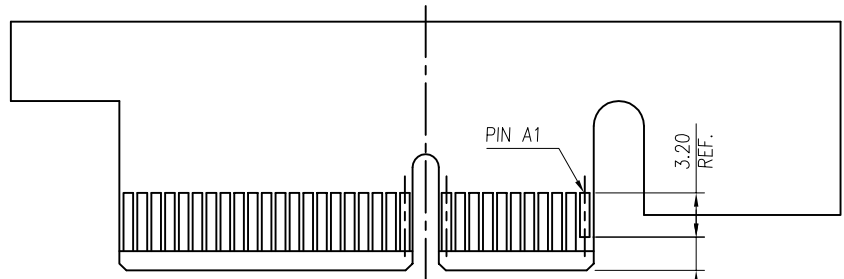

I/O PANEL DIRECTION →
SECONDARY (SOLDER) SIDE

ADD-IN CARD EDGE-FINGER DIMENSIONS

# POS REF.	N	DIM "G"	DIM "F"	"F"
36	6	8.15	6.00	B17
64	20	22.15	20.00	B31
98	37	39.15	37.00	B48
164	70	72.15	70.00	B81

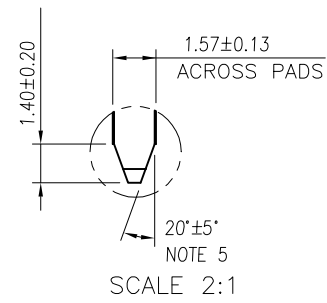

mat'l. code	N/A	surface	58	tolerance	/	projection	product family	EDGE CARD
ltr	ecn no	dr	date	tolerances unless otherwise specified		MM	title	PCI EXPRESS SMT TYPE GEN3 for SIOM
				angles	.X ± 0.30			
				0°±2°	.XX ± 0.20			
					.XXX ± 0.10	scale N/A		
		dr	Stone Li	05/28/15			dwg no	sheet 2 of 4 size
		engr	Stone Li	05/28/15			10073228	A4
		chr	/	05/28/15				
		appd	PeiMing Zheng	05/28/15			type	CUSTOMER Drawing
sheet index	revision sheet							

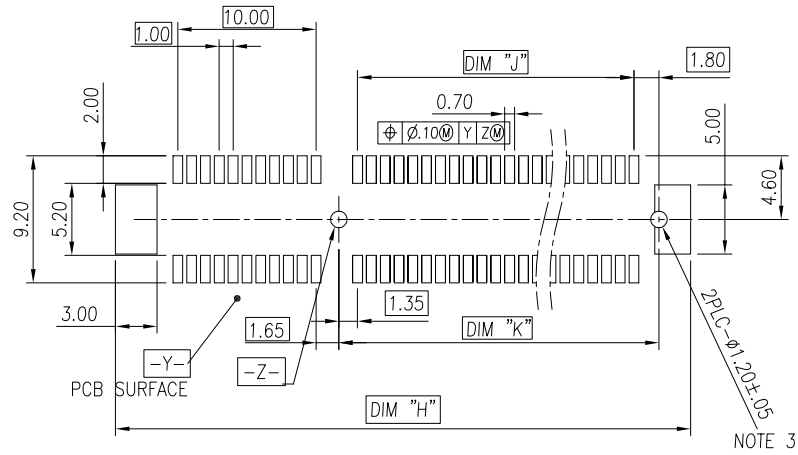

RECOMMENDED PCB LAYOUT, PAD TYPE

DIMENSIONS								
POSITION	A	B $\begin{smallmatrix} +0.15 \\ -0.05 \end{smallmatrix}$	C ± 0.20	D ± 0.23	E ± 0.20	H ± 0.10	J	K ± 0.10
36	6.00	7.65	9.15	25.00	27.00	28.00	6.00	9.15
64	20.00	21.65	23.15	39.00	41.00	42.00	20.00	23.15
98	37.00	38.65	40.15	56.00	58.00	59.00	37.00	40.15
164	70.00	71.65	73.15	89.00	91.00	92.00	70.00	73.15

POSITION OF CAP

mat'l. code		N/A		surface 58		tolerance		projection		product family		EDGE CARD	
ltr	ecn no	dr	date	tolerances unless otherwise specified								title	
				angles	Linear	.X	± 0.30	MM		PCI EXPRESS SMT TYPE GEN3 for SIOM			
				0°±2°	Linear	.XX	± 0.20	scale N/A		sheet 3 of 4			
				dr	Stone Li	05/28/15	FCI		size				
				enrg	Stone Li	05/28/15			10073228				
				chr	/	05/28/15			A4				
				appd	PeiMing Zheng	05/28/15			type				
sheet index		revision sheet											

NOTES:

1.MATERIAL:

HOUSING: HIGH TEMPERATURE NYLON, GLASS FILLED UL94V-0 RATED.

TERMINAL: COPPER ALLOY

PLATING: 50u" NICKEL UNDERPLATE ALL OVER CONTACT AREA PLATING - SEE PRODUCT NUMBER CODE

SOLDER TAIL: TIN - SEE PRODUCT NO. CODE 100u" MIN. OVER 50u" NICKEL

METAL BOARD LOCKS: COPPER ALLOY

FINISH: 100u" TIN OVER 50u" NICKEL UNDERPLATE SEE PRODUCT NUMBER CODE

2.RoHS COMPATIBLE PRODUCT SPECIFICATIONS

a - PLATING:

- "LF" MEANS THE PRODUCT IS LEAD-FREE, 2um MINIMUM MATTE TIN OVER 1.27um MINIMUM NICKEL UNDERPLATE.

b - MANUFACTURING PROCESS COMPATIBILITY

- THE HOUSING WILL WITHSTAND EXPOSURE TO 260°C±5°C SOLDER BATH TEMPERATURE FOR 5 SECONDS IN A REFLOW SOLDER APPLICATION WITH A 1.6mm MIN THICK CIRCUIT BOARD.

PRODUCT NUMBER CODE

10073228 -x 0 x 0 x T □ □

HOUSING COLOR OPTIONS

1-BLACK

RESERVE

PACKAGING OPTIONS

T: TRAY PACKAGING WITHOUT CAP OR MYLAR

M: T&R PACKAGING WITH MYLAR (36P, 64P AND 98P ONLY)

"LF" FOR TERMINAL PLATING OPTION 0,1,2

POS OPTIONS

- 0-36
- 1-64
- 2-98
- 3-164

RESERVE

TERMINAL PLATING OPTIONS

- 0-50u" Ni UNDERPLATE
- 30u" Au CONTACT AREA
- 100u" TIN TAIL AREA ----- COMPATIBLE RoHS
- 1-50u" Ni UNDERPLATE
- 15u" Au CONTACT AREA
- 100u" TIN TAIL AREA ----- COMPATIBLE RoHS
- 2-50u" Ni UNDERPLATE
- GOLD FLASH CONTACT AREA
- 100u" TIN TAIL AREA ----- COMPATIBLE RoHS

mat'l. code		surface		tolerance		projection		product family	
N/A		/		58 /				EDGE CARD	
ltr	ecn no	dr	date	tolerances unless otherwise specified					
				angles	linear	.X ± 0.30			title
				0°±2°	XXX ± 0.20	scale N/A		PCI EXPRESS SMT TYPE GEN3 for SIOM	
				dr	Stone Li	05/28/15	FCI		dwg no
				enrg	Stone Li	05/28/15			sheet 4 of 4
				chr	/	05/28/15			size
				appd	PeiMing Zheng	05/28/15			A4
sheet index		revision sheet		type					
				CUSTOMER Drawing					