

Control cabinet feed-through - VS-BH-M12FSX-10G-RJ45/180 - 1404549

Please be informed that the data shown in this PDF Document is generated from our Online Catalog. Please find the complete data in the user's documentation. Our General Terms of Use for Downloads are valid (<http://phoenixcontact.com/download>)



Control cabinet feed-through, M12, 8-pos., X-coded to RJ45 socket, socket input 180°, IP65/67

Your advantages

- ✓ Compact design
- ✓ 10 Gbps
- ✓ IP65/67
- ✓ UL



Key Commercial Data

Packing unit	1 pc
GTIN	 4 046356 699426
GTIN	4046356699426

Technical data

Mechanical characteristics

Number of positions	8
Number of slots	1
Shielded	yes
Insertion/withdrawal cycles	≥ 100
Cable outlet	straight
Color	black
Mounting type	Rear mounting
Degree of protection	IP65/IP67
Type	Straight

Ambient conditions

Ambient temperature (operation)	-25 °C ... 85 °C
---------------------------------	------------------

Control cabinet feed-through - VS-BH-M12FSX-10G-RJ45/180 - 1404549

Technical data

Ambient conditions

Ambient temperature (storage/transport)	-25 °C ... 85 °C
Degree of protection	IP65
	IP67

Material data

Flammability rating according to UL 94	V0
Housing material	PA
Contact material	Copper alloy

Electrical characteristics

Number of positions	8
Nominal voltage U_N	60 V
Nominal current I_N	0.5 A
Transmission characteristics (category)	CAT6 _A
GRP transmission properties	Ethernet CAT6 _A CAT6 _A
Transmission speed	10 Gbps
Rated current	1.75 A
Rated voltage (III/3)	72 V (DC)

Standards and Regulations

Flammability rating according to UL 94	V0
--	----

Environmental Product Compliance

REACH SVHC	Lead 7439-92-1
China RoHS	For details about hazardous substances go to tab "Downloads", Category "Manufacturer's declaration"

Drawings

Dimensional drawing

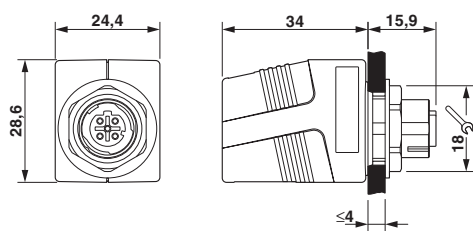

Dimensional drawing

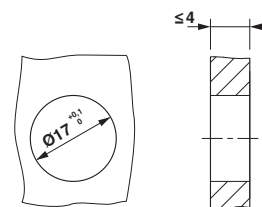

Mounting cutout

Control cabinet feed-through - VS-BH-M12FSX-10G-RJ45/180 - 1404549

Exploded view

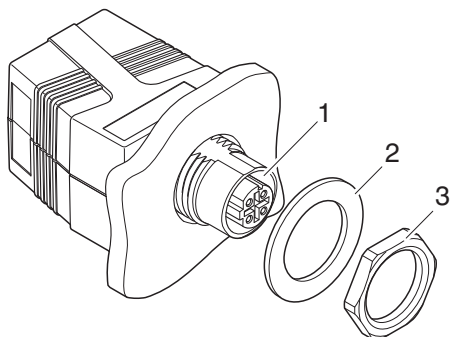

Circuit diagram

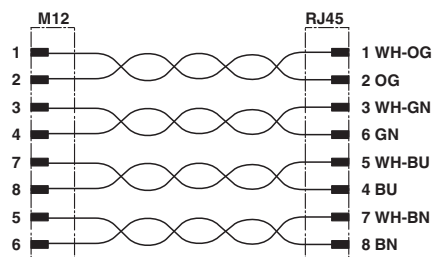

Circuit diagram

Exploded drawing

Approvals

Approvals

Approvals

UL Listed / cUL Listed / EAC / cULus Listed

Ex Approvals

Approval details

UL Listed		http://database.ul.com/cgi-bin/XYV/template/LISEXT/1FRAME/index.htm E335024-20140306
Nominal voltage UN	60 V	
Nominal current IN	0.5 A	

cUL Listed		http://database.ul.com/cgi-bin/XYV/template/LISEXT/1FRAME/index.htm E335024-20140306
Nominal voltage UN	60 V	
Nominal current IN	0.5 A	

EAC		B.01742
-----	--	---------

Control cabinet feed-through - VS-BH-M12FSX-10G-RJ45/180 - 1404549

Approvals

cULus Listed



Phoenix Contact 2018 © - all rights reserved
<http://www.phoenixcontact.com>

PHOENIX CONTACT GmbH & Co. KG
Flachsmarktstr. 8
32825 Blomberg
Germany
Tel. +49 5235 300
Fax +49 5235 3 41200
<http://www.phoenixcontact.com>