

## DESCRIPTION

Demonstration circuit 2588A features the **LTC<sup>®</sup>2387** family driven by a pair of ADA4899-1 driver amplifiers. With up to 15MSPS, these differential input, single channel, 18-/16-Bit, serial, high speed successive approximation register (SAR) ADCs are available in a 32-Pin QFN package. The LTC2387 family has an internal 20ppm/°C reference and a serial LVDS interface. The following text refers to the LTC2387 but applies to all members of the family, the only difference being the sample rate and the number of

bits. The DC2588A demonstrates the AC performance of the LTC2387 in conjunction with the DC718 data collection board. The amplifiers simplify the task of driving the LTC2387 with a signal source.

**Design files for this circuit board are available at <http://www.linear.com/demo/DC2588A>**

LT, LT, LTC, LTM, Linear Technology and the Linear logo are registered trademarks and PScope is a trademark of Linear Technology Corporation. All other trademarks are the property of their respective owners.

## BOARD PHOTO

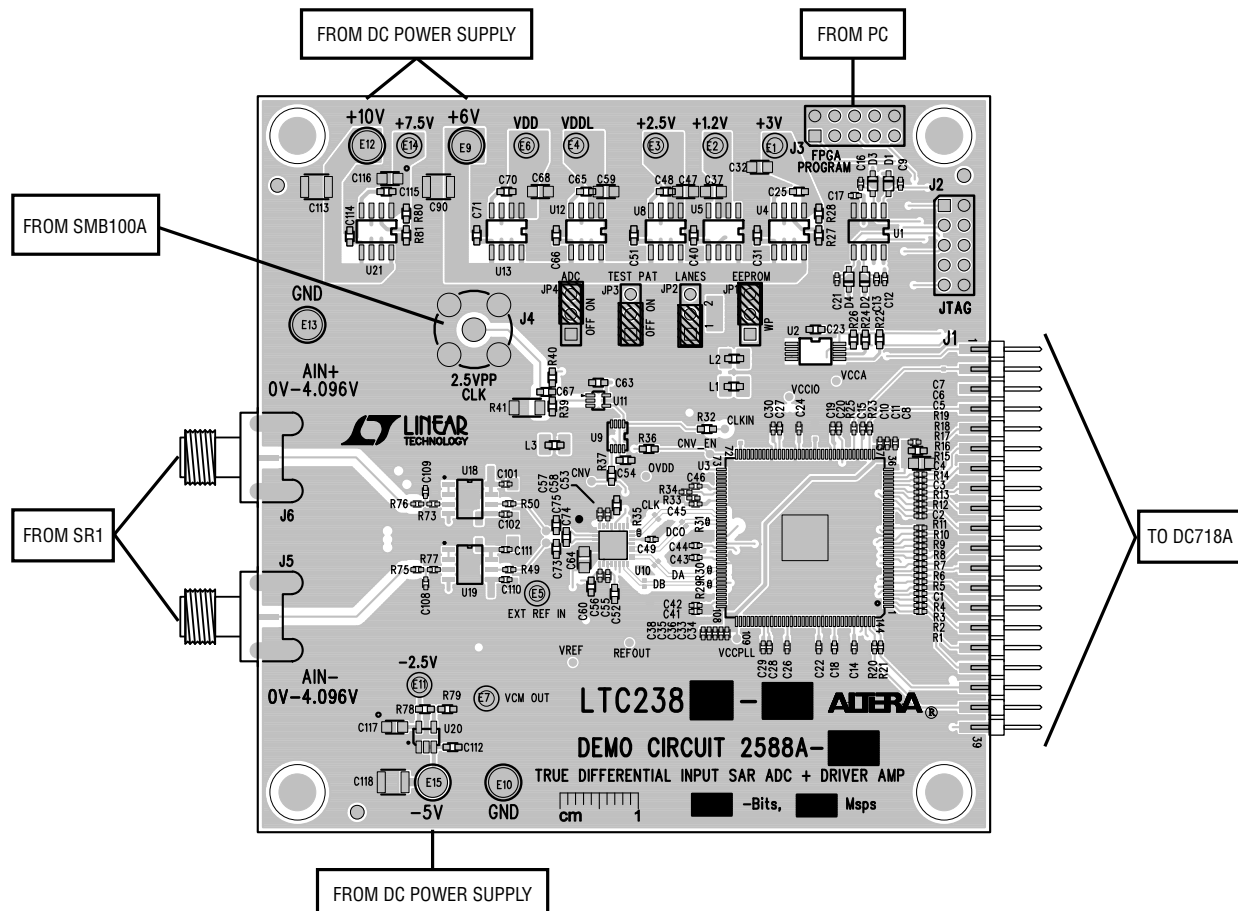

Figure 1. DC2588A Connection Diagram

## DC718 QUICK START PROCEDURE

Connect the +10V, +6V and -5V DC power supplies to the turrets as shown in Figure 1. Note the onboard LDO outputs are available on the -2.5V, +1.2V, +2.5V, +3V, +7.5V,  $V_{DD}$  and  $V_{DDL}$  turrets. Connect the DC2588A to a DC718 USB High Speed Data Collection Board using edge connector J1. Connect the DC718 to a host PC with a standard USB A/B cable. Apply a low noise differential signal to J6 ( $A_{IN}^+$ ) and J5 ( $A_{IN}^-$ ). Note that the DC2588A requires a differential input signal of approximately 8.192V peak-to-peak to reach 0dBFS. If a differential signal source of this amplitude is not available use one of the recommended differential amplifier demo boards available to increase the signal level. For a clock source, apply a low

jitter 10dBm sine wave or square wave to connector J4. See Table 1 for maximum clock frequencies. Note that J4 has a 50 $\Omega$  termination resistor to ground. Run the PScope™ software (Pscope.exe version K73 or later) supplied with DC718 or download it from [www.linear.com/software](http://www.linear.com/software). Complete software documentation is available from the Help menu. Updates can be downloaded from the Tools menu. Check for updates periodically as new features may be added. The PScope software should recognize the DC2588A and configure itself automatically. Click the Collect button (Figure 2) to begin acquiring data. The Collect button then changes to Pause, which can be used to stop data acquisition.

**Table 1. DC2588A Assembly Options**

VERSION	U1 PART NUMBER	MAX CONVERSION RATE	# OF BITS	MAX CLOCK FREQUENCY
DC2588A-A	LTC2387CUH-18#PBF	15Msps	18	15MHz
DC2588A-B	LTC2387CUH-16#PBF	15Msps	16	15MHz
DC2588A-C	LTC2386CUH-18#PBF	10Msps	18	10MHz
DC2588A-D	LTC2386CUH-16#PBF	10Msps	16	10MHz
DC2588A-E	LTC2385CUH-18#PBF	5Msps	18	5MHz
DC2588A-F	LTC2385CUH-16#PBF	5Msps	16	5MHz

## HARDWARE SETUP

### SIGNAL CONNECTIONS

**J2:** JTAG. Factory use only.

**J3:** FPGA Program. Factory use only.

**J4:** CLK IN. This input has a 50 $\Omega$  termination resistor, and is intended to be driven by a low jitter, 10dBm sine or square wave. To achieve full AC performance of this part, the clock jitter should be kept under 2ps<sub>RMS</sub>. This input is capacitively coupled so that the input clock can be either 0V to 3.3V or  $\pm 1.65V$ . This eliminates the need for level shifting. To run at the maximum conversion rate, apply the frequency specified in Table 1.

**J5:**  $A_{IN}^-$  Input. This is the negative signal input.

**J6:**  $A_{IN}^+$  Input. This is the positive signal input.

### JUMPERS

**JP1:** EEPROM. Factory use only.

**JP2:** Lanes. Use this jumper to select either single lane or two lane data output mode from the LTC2387. The default setting is 1. The 1 setting clocks out all data on pin DA of the LTC2387. The 2 setting clocks out data alternately on pins DA and DB of the LTC2387.

**JP3:** Test Pattern. Use this jumper to deliver a fixed repeating test pattern from the LTC2387. The default setting is OFF. The output data will be -97796 if the jumper is in the ON position in 1 lane mode, and will be -52996 in 2 lane mode.

**JP4:** ADC ON. Use this jumper to enable or disable the ADC. The default setting is ON.

# HARDWARE SETUP

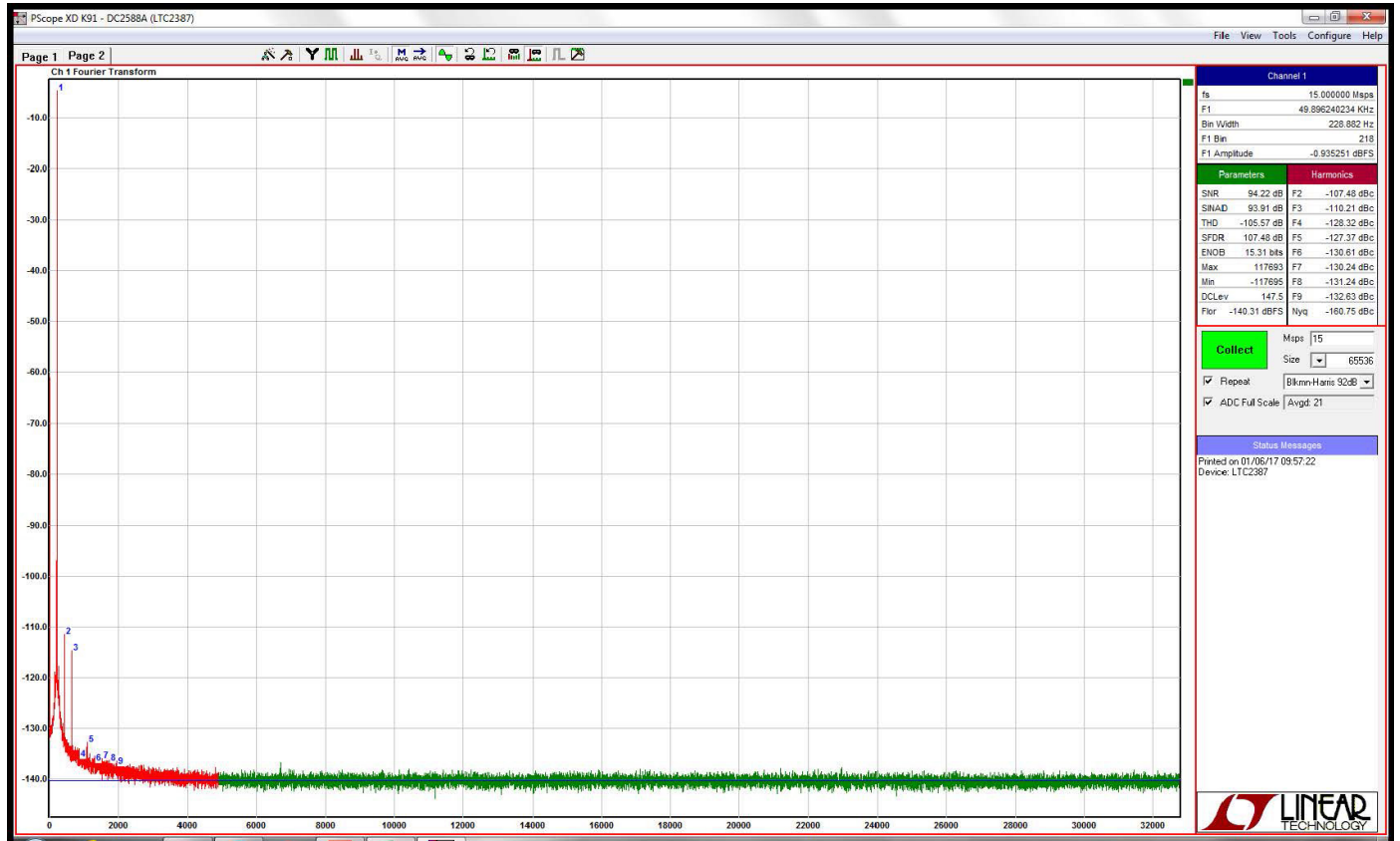

Figure 2. DC2588A PScope Screenshot

# DEMO MANUAL DC2588A

---

## DEMONSTRATION BOARD IMPORTANT NOTICE

Linear Technology Corporation (LTC) provides the enclosed product(s) under the following **AS IS** conditions:

This demonstration board (DEMO BOARD) kit being sold or provided by Linear Technology is intended for use for **ENGINEERING DEVELOPMENT OR EVALUATION PURPOSES ONLY** and is not provided by LTC for commercial use. As such, the DEMO BOARD herein may not be complete in terms of required design-, marketing-, and/or manufacturing-related protective considerations, including but not limited to product safety measures typically found in finished commercial goods. As a prototype, this product does not fall within the scope of the European Union directive on electromagnetic compatibility and therefore may or may not meet the technical requirements of the directive, or other regulations.

If this evaluation kit does not meet the specifications recited in the DEMO BOARD manual the kit may be returned within 30 days from the date of delivery for a full refund. **THE FOREGOING WARRANTY IS THE EXCLUSIVE WARRANTY MADE BY THE SELLER TO BUYER AND IS IN LIEU OF ALL OTHER WARRANTIES, EXPRESSED, IMPLIED, OR STATUTORY, INCLUDING ANY WARRANTY OF MERCHANTABILITY OR FITNESS FOR ANY PARTICULAR PURPOSE. EXCEPT TO THE EXTENT OF THIS INDEMNITY, NEITHER PARTY SHALL BE LIABLE TO THE OTHER FOR ANY INDIRECT, SPECIAL, INCIDENTAL, OR CONSEQUENTIAL DAMAGES.**

The user assumes all responsibility and liability for proper and safe handling of the goods. Further, the user releases LTC from all claims arising from the handling or use of the goods. Due to the open construction of the product, it is the user's responsibility to take any and all appropriate precautions with regard to electrostatic discharge. Also be aware that the products herein may not be regulatory compliant or agency certified (FCC, UL, CE, etc.).

No License is granted under any patent right or other intellectual property whatsoever. **LTC assumes no liability for applications assistance, customer product design, software performance, or infringement of patents or any other intellectual property rights of any kind.**

LTC currently services a variety of customers for products around the world, and therefore this transaction **is not exclusive**.

**Please read the DEMO BOARD manual prior to handling the product.** Persons handling this product must have electronics training and observe good laboratory practice standards. **Common sense is encouraged.**

This notice contains important safety information about temperatures and voltages. For further safety concerns, please contact a LTC application engineer.

Mailing Address:

Linear Technology  
1630 McCarthy Blvd.  
Milpitas, CA 95035

Copyright © 2004, Linear Technology Corporation