

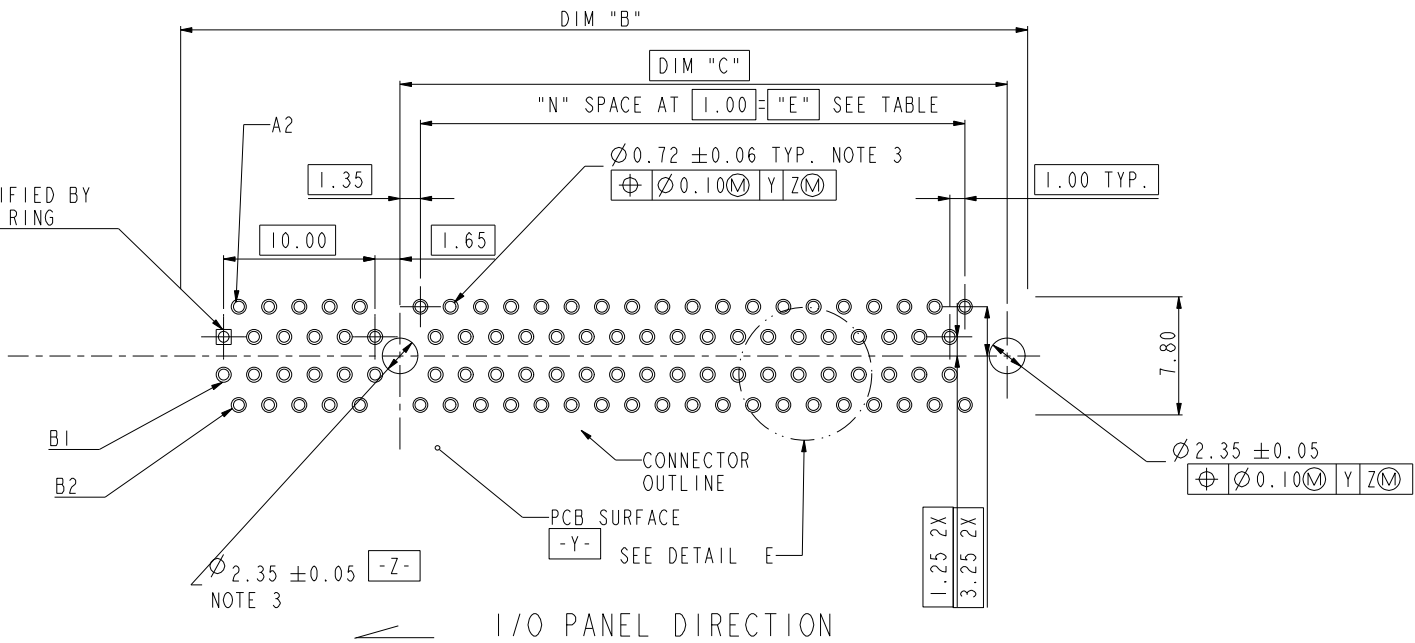



Copyright FCI.

PIN #A1 IDENTIFIED BY SQUARE ANNULAR RING



RECOMMENDED FOOTPRINT

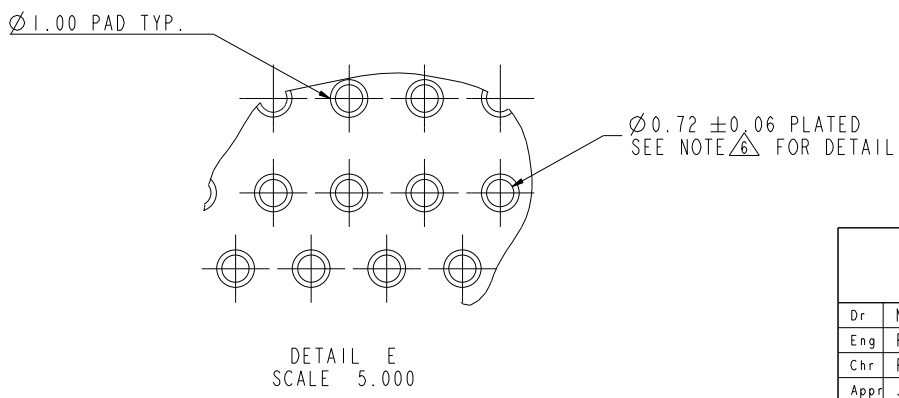

tolerance unless otherwise specified	
linear	.X ± .3 .XX ± .2 .XXX ± .1
angles	0° ± 2°

www.fciconnect.com			tolerance	projection	MM
Dr	MAGGIE WU	07/23/04	✓	⊕	↔
Eng	R Y LIU	07/23/04		size	A4
Chr	PAUL WANG	07/23/04		Scale	1.000
Appr	JOSEPH HSIA	07/23/04		ECN	DG09-0045
PCI EXPRESS PRESS-FIT ASS'Y			dwg no	10039755	Rev. K
catalog no			* CUSTOMER DRAWING sheet 2 of 6		

A

B

C

D

A

B

C

D

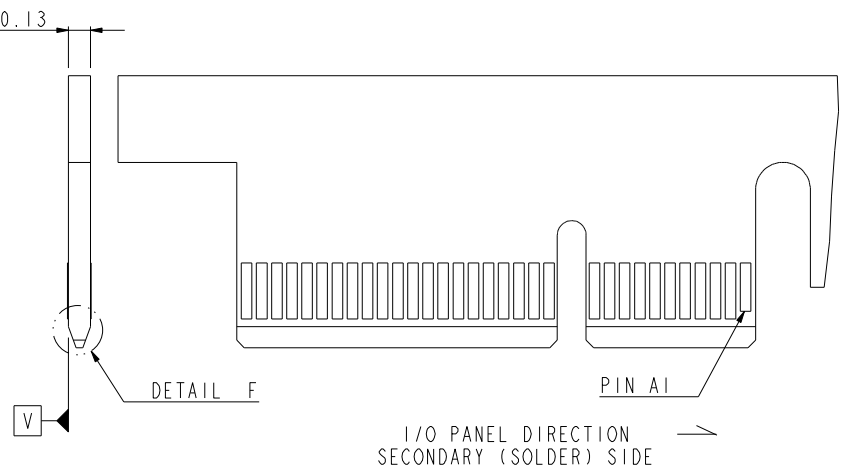
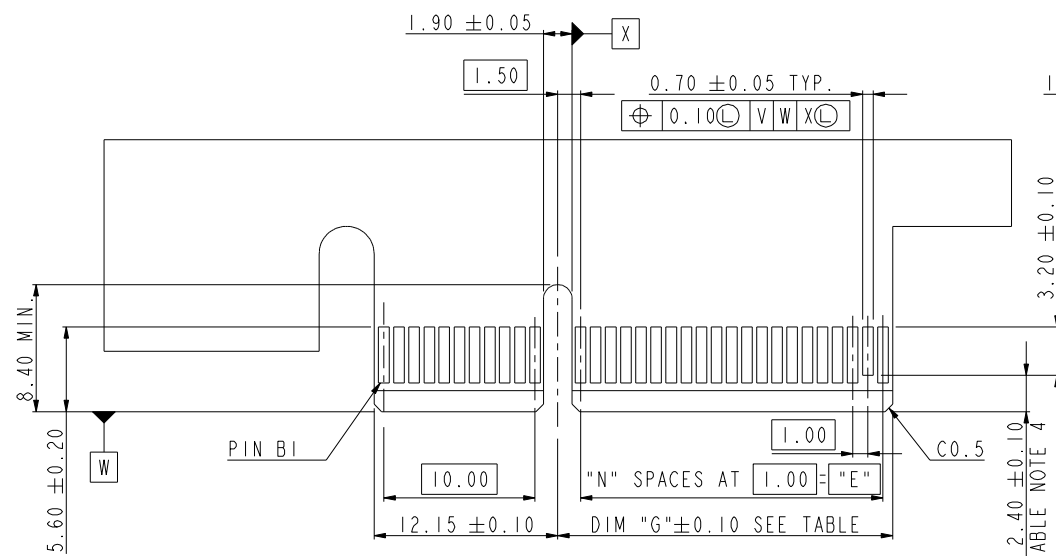

← I/O PANEL DIRECTION  
PRIMARY (COMPONENT) SIDE

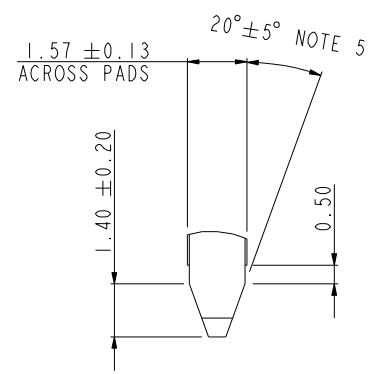

DETAIL F  
SCALE 5.000

# POS REF.	N	DIM "G"	"F"
98	37	39.15	B48
164	70	72.15	B81

tolerance unless otherwise specified	
linear	.X ± .3 .XX ± .2 .XXX ± .1
angles	0° ± 2°

www.fciconnect.com			tolerance	projection	MM
Dr	MAGGIE WU	07/23/04	Product family	size	A4
Eng	R Y LIU	07/23/04	Spec ref	Scale	1.000
Chr	PAUL WANG	07/23/04	Material	ECN	DG09-0045
Appr	JOSEPH HSIA	07/23/04			
FCI PCI EXPRESS PRESS-FIT ASS'Y			dwg no	10039755	Rev. K
catalog no			* CUSTOMER DRAWING sheet 3 of 6		



Copyright FCI.

1

2

3

4

A

B

C

D

A

B

C

D

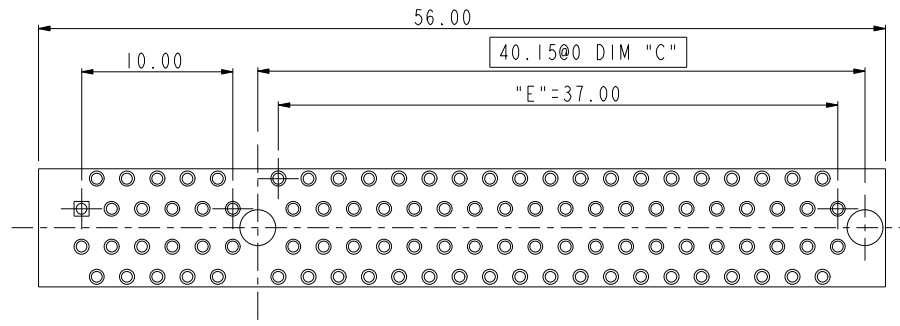

98p  
SCALE 2.000

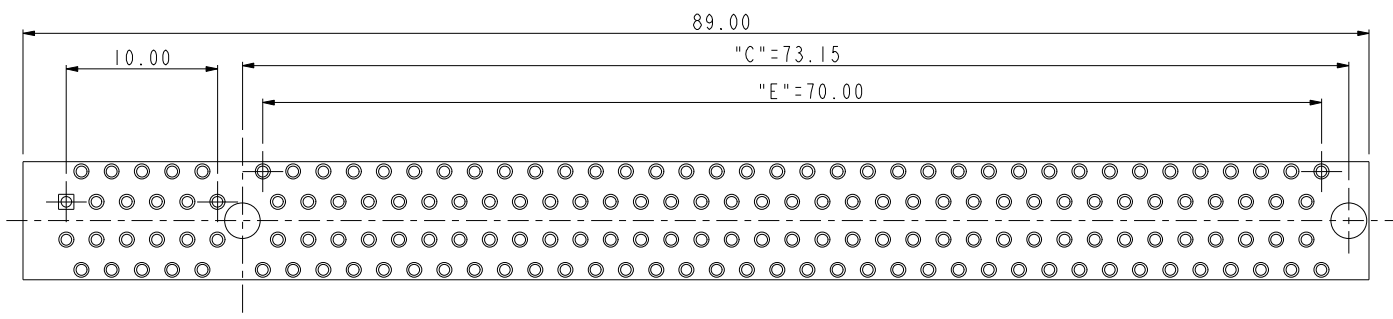

164P  
SCALE 2.000

# RECOMMENDED FOOTPRINT LAYOUT

www.fciconnect.com			✓ tolerance	projection	MM
Dr	MAGGIE WU	07/23/04	Product family	3G10	size A4
Eng	R Y LIU	07/23/04	Spec ref	*	Scale 1.000
Chr	PAUL WANG	07/23/04	Material	*	ECN DG09-0045
Appr	JOSEPH HSIA	07/23/04			
		PCI EXPRESS PRESS-FIT ASS'Y		dwg no	10039755
catalog no		*		CUSTOMER	sheet 4 of 6

REV F - 2006-04-17

2

PDM: Rev:K

STATUS:Released

4 Printed: Mar 15, 2011



Copyright FCI.

NOTES:

1. MATERIAL:

HOUSING: HIGH TEMPERATURE NYLON, GLASS FILLED UL94V-0 RATED. SUITABLE FOR REFLOW SOLDERING.

TERMINAL: COPPER ALLOY

PLATING: 50u" NICKEL UNDERPLATE ALL OVER

CONTACT AREA PLATING - SEE PRODUCT NUMBER CODE

SOLDER TAIL: TIN - 100u" MIN. OVER 50u" NICKEL OR TIN/LEAD

100u" MIN. SEE PRODUCT NUMBER CODE

2. PRODUCT SPECIFICATION: GS-12-319

THE HORIZONTAL AXIS FOR THE HOLE PATTERN IS ESTABLISHED BY A LINE THROUGH THE CENTER OF THE TWO Ø2.35 HOLES. THE VERTICAL AXIS IS 90° TO THE HORIZONTAL AXIS, THROUGH THE CENTER OF DATUM Z.

NO TIE BAR PERMITTED FROM CARD EDGE TO LEADING EDGE OF PAD FOR PINS A1 AND PIN NUMBERS "F".

CHAMFER EDGES MUST BE FREE OF CUTTING BURRS.

ALL PTH SHOULD BE 0.76~0.83 mm DIA DRILLED AND 0.025~0.05 mm.

ELECTRO-DEPOSITED COPPER THK ON THROUGH HOLE WALL.

7. RoHS COMPATIBLE PRODUCT SPECIFICATIONS

a-PLATING:

- "LF" MEANS THE PRODUCT IS LEAD-FREE, 2um MINIMUM MATTE TIN OVER 1.27um MINIMUM NICKEL UNDERPLATE.

b-MANUFACTURING PROCESS COMPATIBILITY

- THE HOUSING WILL WITHSTAND EXPOSURE TO 260°C±5°C SOLDER BATH TEMPERATURE FOR 5 SECONDS IN A REFLOW SOLDER APPLICATION WITH A 1.6mm MIN THICK CIRCUIT BOARD.

CONNECTOR	# POS	REF.	N	DIM "A"	DIM "B"	DIM "C"	DIM "E"
1 PORT	36		6	7.65	25.00	9.15	6.00
4 PORT	64		20	21.65	39.00	23.15	20.00
8 PORT	98		37	38.65	56.00	40.15	37.00
16 PORT	164		70	71.65	89.00	73.15	70.00

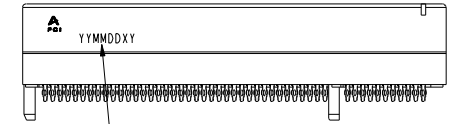

Date code:  
 "YY" means year number  
 "MM" means month number  
 "DD" means day number  
 "X" means manufacture location  
 "D" means made in Dongguan site  
 "Y" means shift number  
 If date code is 060626D1, it means this part is made by shift 1 in 2006/06/26 and manufactured in Dongguan site  
 Date code should be laser mark

PRODUCT NUMBER CODE

10039755 - X X X X X X X X

HOUSING COLOR OPTIONS  
1-BLACK

PEGS OPTIONS  
0-PLASTIC PEGS

TERMINAL PLATING OPTIONS

- 0-50u" Ni UNDERPLATE  
30u" Au CONTACT AREA  
100u" TIN TAIL AREA -----COMPATIBLE RoHS
- 1-50u" Ni UNDERPLATE  
15u" Au CONTACT AREA  
100u" TIN TAIL AREA -----COMPATIBLE RoHS
- 2-50u" Ni UNDERPLATE  
GOLD FLASH CONTACT AREA  
100u" TIN TAIL AREA -----COMPATIBLE RoHS
- 3-50u" Ni UNDERPLATE  
30u" Au CONTACT AREA  
100u" TIN/LEAD TAIL AREA -----RoHS COMPLIANT EXCEPT Pb
- 4-50u" Ni UNDERPLATE  
15u" Au CONTACT AREA  
100u" TIN/LEAD TAIL AREA -----RoHS COMPLIANT EXCEPT Pb
- 5-50u" Ni UNDERPLATE  
GOLD FLASH CONTACT AREA  
100u" TIN/LEAD TAIL AREA -----RoHS COMPLIANT EXCEPT Pb

LEAD FREE OPTION  
"LF" FOR TERMINAL PLATING OPTION 0,1,2  
LEAVE BLANK FOR TERMINAL PLATING 3,4,5

PACKAGING OPTIONS  
T-TRAY PACKAGING

POS OPTIONS

- 0-36
- 1-64
- 2-98
- 3-164

	DIM "D"	SUGGESTED PCB THICKNESS
0	2.00±0.20	2.36
1	3.25±0.20	4.19

TAIL LENGTH OPTIONS

tolerance unless otherwise specified	
linear	.X ± .3
	.XX ± .2
angles	.XXX ± .1
	0° ± 2°

www.fciconnect.com			tolerance	projection	MM
Dr	MAGGIE WU	07/23/04	Product family	size A4	Scale 1.000
Eng	R Y LIU	07/23/04	Spec ref	ECN	DG09-0045
Chr	PAUL WANG	07/23/04	Material		
Appr	JOSEPH HSIA	07/23/04			
FCI		PCI EXPRESS PRESS-FIT ASS'Y		dwg no	10039755
catalog no		* CUSTOMER DRAWING		sheet	5 of 6
				Rev.	K



Copyright FCI.

1

2

3

4

A

B

C

D

A

B

C

D

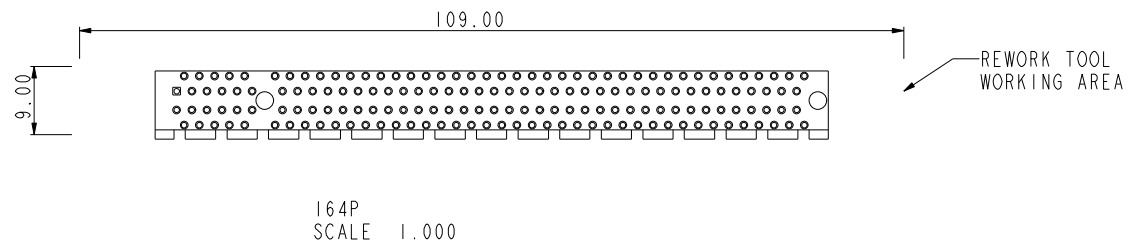
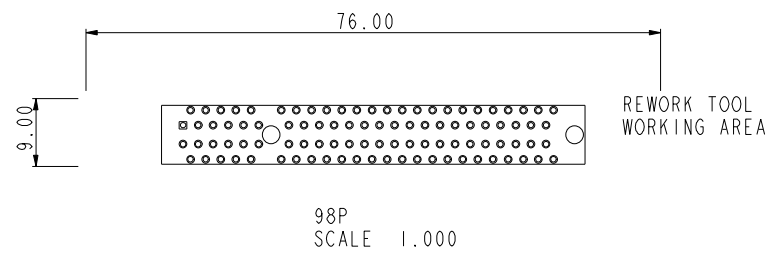
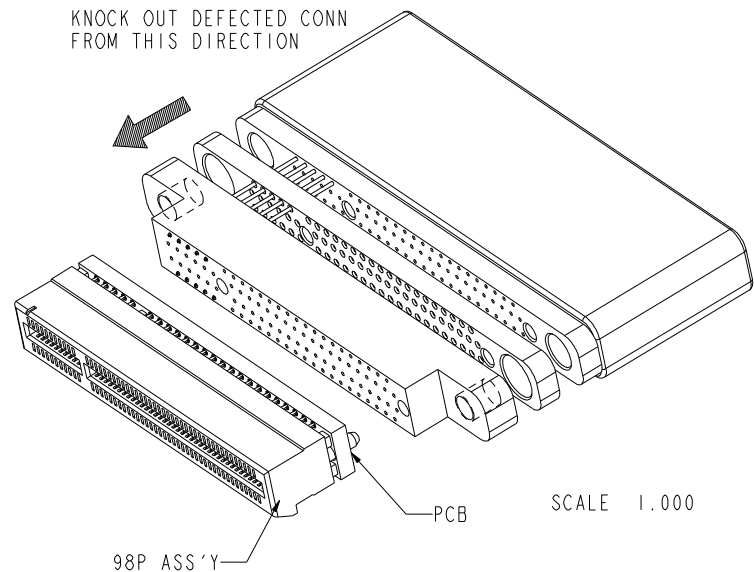

tolerance unless otherwise specified	
linear	.X ± .3 .XX ± .2 .XXX ± .1
angles	0° ± 2°

www.fciconnect.com			✓ tolerance	projection	MM
Dr	MAGGIE WU	07/23/04	Product family	size	A4
Eng	R Y LIU	07/23/04	Spec ref	Scale	1.000
Chr	PAUL WANG	07/23/04	Material	ECN	DG09-0045
Appr	JOSEPH HSIA	07/23/04			
			PCI EXPRESS PRESS-FIT ASS'Y		Rev. K
catalog no				dwg no	10039755
				* CUSTOMER DRAWING	sheet 6 of 6



Copyright FCI.

2