

PART NUMBER	SML-LX2832AC-TR	REV.	D
DATE	E.C.N. NUMBER AND REVISION COMMENTS		REV.
03.14.03	E.C.N. #10967.		A
02.08.05	E.C.N. #11148.		B
10.16.07	E.C.N. #11450.		C
04.30.10	E.C.N. #11627.		D

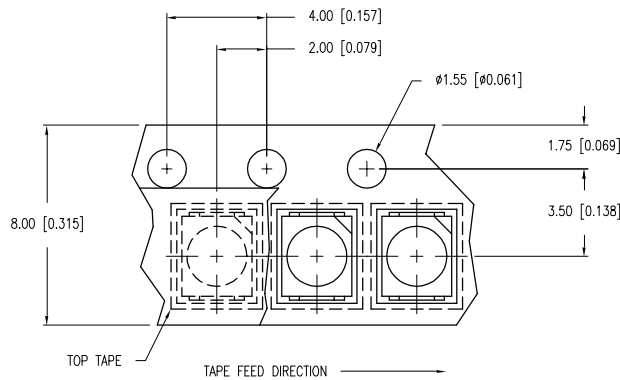

RECOMMENDED SOLDER PAD LAYOUT

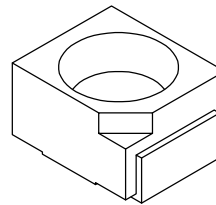
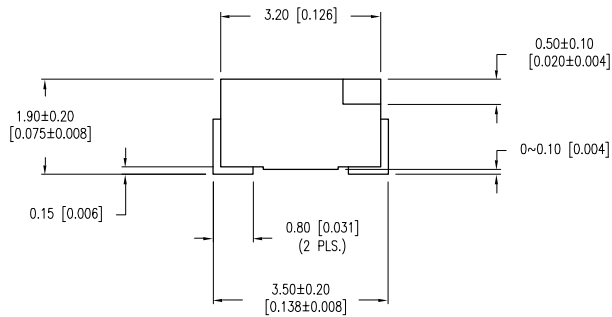
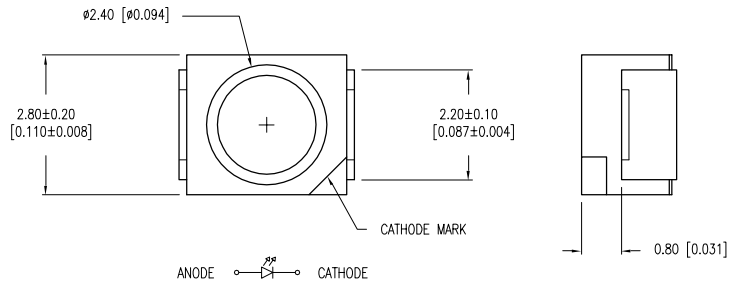
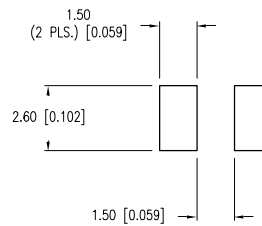

ELECTRO-OPTICAL CHARACTERISTICS  $T_A = 25^\circ\text{C}$   $I_f = 20\text{mA}$

PARAMETER	MIN	TYP	MAX	UNITS	TEST COND
PEAK WAVELENGTH		605		nm	
FORWARD VOLTAGE		2.0	2.5	$V_f$	
REVERSE VOLTAGE	5			$V_r$	$I_f = 100\mu\text{A}$
AXIAL INTENSITY		25		mcd	$I_f = 20\text{mA}$
VIEWING ANGLE		120		$2x$ theta	
EMITTED COLOR:	AMBER				
EPOXY LENS FINISH:	WATER CLEAR				

LIMITS OF SAFE OPERATION AT  $25^\circ\text{C}$

PARAMETER	MAX	UNITS
PEAK FORWARD CURRENT*	160	mA
STEADY CURRENT	30	mA
POWER DISSIPATION	100	mW
DERATE FROM $25^\circ\text{C}$	-1.2	$\text{mW}/^\circ\text{C}$
OPERATING TEMP.	-30 TO +85	$^\circ\text{C}$
STORAGE TEMP.	-40 TO +85	$^\circ\text{C}$
SOLDERING TEMP.	+260	$^\circ\text{C}$
2.0mm FROM BODY	3	SEC. MAX

\*  $t < 10\mu\text{s}$

LEAD FREE REFLOW PROFILE

10 SEC. MAX.

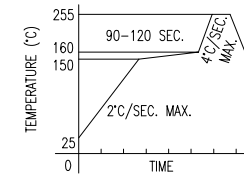

TOTAL TIME ABOVE  $220^\circ\text{C}$  IS 60 SECONDS MAX.

NOTES:

- THE POLARITY MARK IS ORIENTED TOWARDS THE TAPE SPROCKET HOLE.

CAUTION: MOISTURE SENSITIVE DEVICE PER JEDEC LEVEL 2 STANDARDS

\*UNLESS OTHERWISE SPECIFIED TOLERANCES PER DECIMAL PRECISION ARE: X= $\pm 1$  ( $\pm 0.039$ ), X.X= $\pm 0.5$  ( $\pm 0.020$ ), X.XX= $\pm 0.25$  ( $\pm 0.010$ ), X.XXX= $\pm 0.127$  ( $\pm 0.005$ ). LEAD SIZE= $\pm 0.05$  ( $\pm 0.002$ ), LEAD LENGTH= $\pm 0.75$  ( $\pm 0.030$ ). MIN= $^{+0.00}$  DECIMAL PRECISION  $^{-0.00}$  DECIMAL PRECISION



290 E. HELEN ROAD  
PALATINE, IL 60067-6976  
PHONE: +1.847.359.2790  
FAX: +1.847.359.6538  
WEB: WWW.LUMEX.COM

2.8mm X 3.2mm SML /W REFLECTOR, 605nm LED, WATER CLEAR LENS, 2,000 PCS PER TAPE & REEL.

\*\*THE SPECIFICATIONS MAY CHANGE AT ANY TIME WITHOUT NOTICE DUE TO NEW MATERIALS OR PRODUCT IMPROVEMENT.\*\*

CONFIDENTIAL INFORMATION  
THE INFORMATION CONTAINED IN THIS DOCUMENT IS THE PROPERTY OF LUMEX INC. EXCEPT AS SPECIFICALLY AUTHORIZED IN WRITING BY LUMEX INC., THE HOLDER OF THIS DOCUMENT SHALL KEEP ALL INFORMATION CONTAINED HEREIN CONFIDENTIAL AND SHALL PROTECT SAME IN WHOLE OR IN PART FROM DISCLOSURE AND DISSEMINATION TO ALL THIRD PARTIES.

DATE:	03.28.01	DRAWN BY:	CT
PAGE:	1 OF 1	CHKD BY:	SS
SCALE:	N/A	APRVD BY:	KF
UNIT:	mm [INCH]		

