

Single-channel HOTLink II™ Transceiver

Features

- Second-generation HOTLink® technology
- Compliant to multiple standards
 - ESCON®, DVB-ASI, fibre channel and gigabit ethernet (IEEE802.3z)
 - CPRI™ compliant
 - CYV15G0101DXB compliant to SMPTE 259M and SMPTE 292M
 - 8B/10B encoded or 10-bit unencoded data
- Single-channel transceiver operates from 195 to 1500 MBaud serial data rate
- Selectable parity check/generate
- Selectable input clocking options
- Selectable output clocking options
- MultiFrame™ Receive Framer
 - Bit and byte alignment
 - Comma or full K28.5 detect
 - Single- or multi-byte framer for byte alignment
 - Low-latency option
- Synchronous LVTTTL parallel input and parallel output interface
- Internal phase-locked loops (PLLs) with no external PLL components
- Dual differential PECL-compatible serial inputs
 - Internal DC-restoration
- Dual differential PECL-compatible serial outputs
 - Source matched for driving 50 Ω transmission lines
 - No external bias resistors required
 - Signaling-rate controlled edge-rates
- Optional elasticity buffer in receive path
- Optional phase align buffer in transmit path

- Compatible with
 - Fiber-optic modules
 - Copper cables
 - Circuit board traces
- JTAG boundary scan
- Built-in self-test (BIST) for at-speed link testing
- Per-channel link quality indicator
 - Analog signal detect
 - Digital signal detect
- Low power 1.25 W at 3.3 V typical
- Single 3.3 V supply
- 100-ball BGA
- Pb-free package option available
- 0.25 μ BiCMOS technology

Functional Description

The CYP15G0101DXB^[1] single-channel HOTLink II™ transceiver is a point-to-point communications building block allowing the transfer of data over a high-speed serial link (optical fiber, balanced, and unbalanced copper transmission lines) at signaling speeds ranging from 195 to 1500 MBaud.

The transmit channel accepts parallel characters in an input register, encodes each character for transport, and converts it to serial data. The receive channel accepts serial data and converts it to parallel data, frames the data to character boundaries, decodes the framed characters into data and special characters, and presents these characters to an output register. Figure 1 illustrates typical connections between independent host systems and corresponding CYP(V)15G0101DXB parts. As a second-generation HOTLink device, the CYP(V)15G0101DXB extends the HOTLink II family with enhanced levels of integration and faster data rates, while maintaining serial-link compatibility (data, command, and BIST) with other HOTLink devices.

Figure 1. HOTLink II System Connections

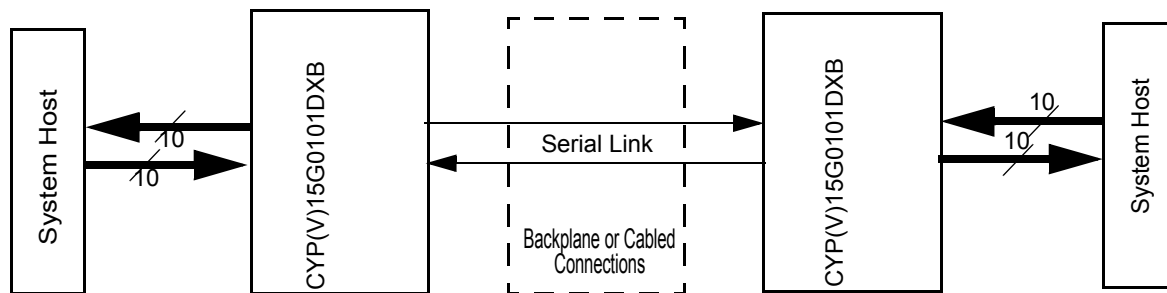

Note

1. CYV15G0101DXB refers to SMPTE 259M and SMPTE 292M compliant devices. CYP15G0101DXB refers to devices not compliant to SMPTE 259M and SMPTE 292M pathological test requirements. CYP(V)15G0101DXB refers both devices.

The CYV15G0101DXB satisfies the SMPTE 259M and SMPTE 292M compliance as per the EG34-1999 pathological test requirements. The transmit (TX) section of the CYP(V)15G0101DXB single-channel HOTLink II consists of a byte-wide channel. The channel can accept either eight-bit data characters or pre-encoded 10-bit transmission characters. Data characters are passed from the transmit input register to an embedded 8B/10B encoder to improve their serial transmission characteristics. These encoded characters are then serialized and output from dual positive ECL (PECL)-compatible differential transmission-line drivers at a bit-rate of either 10 or 20 times the input reference clock.

The receive (RX) section of the CYP(V)15G0101DXB single-channel HOTLink II consists of a byte-wide channel. The channel accepts a serial bit-stream from one of two PECL-compatible differential line receivers and, using a completely integrated PLL clock synchronizer, recovers the timing information necessary for data reconstruction. The recovered bit-stream is deserialized and framed into characters, 8B/10B decoded, and checked for transmission errors. Recovered decoded characters are then written to an internal elasticity buffer, and presented to the destination host system. The integrated 8B/10B encoder/decoder may be bypassed for systems that present externally encoded or scrambled data at the parallel interface.

The parallel I/O interface may be configured for numerous forms of clocking to provide the highest flexibility in system architecture. In addition to clocking the transmit path interfaces from one or multiple sources, the receive interface may be configured to present data relative to a recovered clock or to a local reference clock.

The transmit and the receive channels contain BIST pattern generators and checkers, respectively. This BIST hardware allows at-speed testing of the high-speed serial data paths in both transmit and receive sections, as well as across the interconnecting links.

HOTLink II devices are ideal for a variety of applications where parallel interfaces can be replaced with high-speed, point-to-point serial links. Some applications include interconnecting backplanes on switches, routers, base-stations, servers and video transmission systems.

The CYV15G0101DXB is verified by testing to be compliant to all the pathological test patterns documented in SMPTE EG34-1999, for both the SMPTE 259M and 292M signaling rates. The tests ensure that the receiver recovers data with no errors for the following patterns:

1. Repetitions of 20 ones and 20 zeros.
2. Single burst of 44 ones or 44 zeros.
3. Repetitions of 19 ones followed by 1 zero or 19 zeros followed by 1 one.

Transceiver Logic Block Diagram

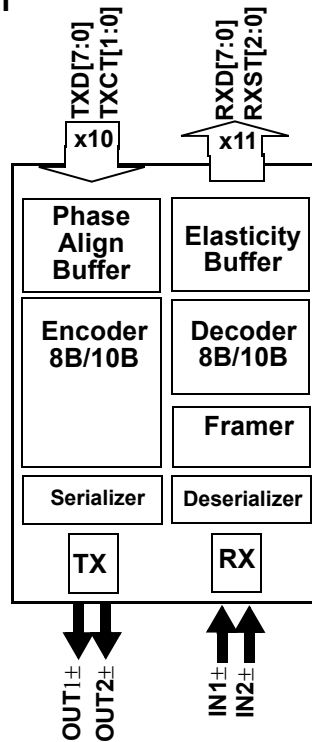

Logic Block Diagram

-- ▷ = Internal Signal

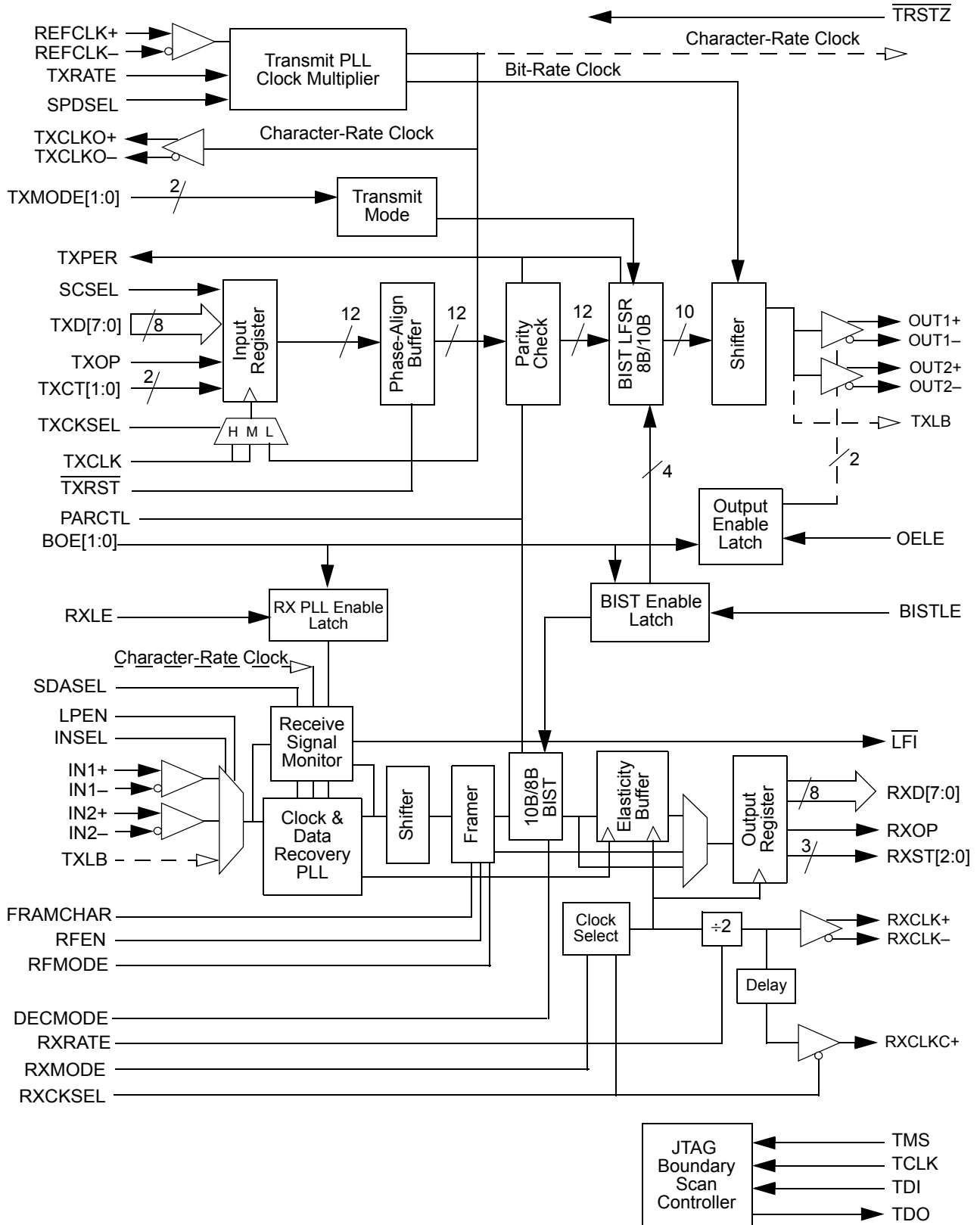

Contents

Pin Configurations	5	CYP(V)15G0101DXB AC Characteristics	27
Pin Descriptions	6	Switching Waveforms for	
CYP(V)15G0101DXB HOTLink II Operation	12	the HOTLink II Transmitter	29
CYP(V)15G0101DXB Transmit Data Path	12	X3.230 Codes and Notation Conventions	33
Transmit Modes	13	Notation Conventions	33
Transmit BIST	15	8B/10B Transmission Code	33
Serial Output Drivers	16	Transmission Order	33
Transmit PLL Clock Multiplier	16	Valid and Invalid Transmission Characters	33
CYP(V)15G0101DXB Receive Data Path	16	Use of the Tables for Generating	
Serial Line Receivers	16	Transmission Characters	34
Signal Detect/Link Fault	17	Use of the Tables for Checking	
Clock/Data Recovery	18	the Validity of Received Transmission Characters	34
Deserializer/Framer	18	Ordering Information	40
10B/8B Decoder Block	19	Ordering Code Definitions	40
Receive BIST Operation	19	Package Diagram	41
Receive Elasticity Buffer	20	Acronyms	42
Receive Modes	20	Document Conventions	42
Power Control	20	Units of Measure	42
Output Bus	21	Document History Page	43
Parity Generation	22	Sales, Solutions, and Legal Information	45
JTAG Support	23	Worldwide Sales and Design Support	45
Maximum Ratings	25	Products	45
Power-up Requirements	25	PSoC® Solutions	45
DC Electrical Characteristics	25	Cypress Developer Community	45
AC Test Loads and Waveforms	26	Technical Support	45

Pin Configurations

Top View

	1	2	3	4	5	6	7	8	9	10
A	V _{CC}	IN2+	V _{CC}	OUT2-	RXMODE	TXMODE[1]	IN1+	V _{CC}	OUT1-	V _{CC}
B	V _{CC}	IN2-	TDO	OUT2+	TXRATE	TXMODE[0]	IN1-	#NC ^[2]	OUT1+	V _{CC}
C	RFEN	LPEN	RXLE	RXCLKC+	RXRATE	SDASEL	SPDSEL	PARCTL	RFMODE	INSEL
D	BOE[0]	BOE[1]	FRAMCHAR	GND	GND	GND	GND	TMS	TRSTZ	TDI
E	BISTLE	DECMODE	OELE	GND	GND	GND	GND	TCLK	RXCKSEL	TXCKSEL
F	RXST[2]	RXST[1]	RXST[0]	GND	GND	GND	GND	TXPER	REFCLK-	REFCLK+
G	RXOP	RXD[1]	RXD[5]	GND	GND	GND	GND	TXOP	TXCLKO+	TXCLKO-
H	RXD[0]	RXD[2]	RXD[6]	LFI	TXCT[1]	TXD[6]	TXD[3]	TXCLK	TXRST	#NC ^[2]
J	V _{CC}	RXD[3]	RXD[7]	RXCLK-	TXCT[0]	TXD[5]	TXD[2]	TXD[0]	#NC ^[2]	V _{CC}
K	V _{CC}	RXD[4]	V _{CC}	RXCLK+	TXD[7]	TXD[4]	TXD[1]	V _{CC}	SCSEL	V _{CC}

Bottom View

	10	9	8	7	6	5	4	3	2	1	
V _{CC}	OUT1-	V _{CC}	IN1+	TXMODE[1]	RXMODE	OUT2-	V _{CC}	IN2+	V _{CC}		A
V _{CC}	OUT1+	#NC ^[2]	IN1-	TXMODE[0]	TXRATE	OUT2+	TDO	IN2-	V _{CC}		B
INSEL	RFMODE	PARCTL	SPDSEL	SDASEL	RXRATE	RXCLKC+	RXLE	LPEN	RFEN		C
TDI	TRSTZ	TMS	GND	GND	GND	GND	FRAMCHAR	BOE[1]	BOE[0]		D
TXCKSEL	RXCKSEL	TCLK	GND	GND	GND	GND	OELE	DECMODE	BISTLE		E
REFCLK+	REFCLK-	TXPER	GND	GND	GND	GND	RXST[0]	RXST[1]	RXST[2]		F
TXCLKO-	TXCLKO+	TXOP	GND	GND	GND	GND	RXD[5]	RXD[1]	RXOP		G
#NC ^[2]	TXRST	TXCLK	TXD[3]	TXD[6]	TXCT[1]	LFI	RXD[6]	RXD[2]	RXD[0]		H
V _{CC}	#NC ^[2]	TXD[0]	TXD[2]	TXD[5]	TXCT[0]	RXCLK-	RXD[7]	RXD[3]	V _{CC}		J
V _{CC}	SCSEL	V _{CC}	TXD[1]	TXD[4]	TXD[7]	RXCLK+	V _{CC}	RXD[4]	V _{CC}		K

Note

2. #NC = Do Not Connect.

Pin Descriptions

CYP(V)15G0101DXB single-channel HOTLink II

Pin Name	I/O Characteristics	Signal Description
Transmit Path Data Signals		
TXPER	LVTTL output, changes relative to REFCLK↑ ^[3]	<p>Transmit path parity error. Active HIGH. Asserted (HIGH) if parity checking is enabled (PARCTL ≠ LOW) and a parity error is detected at the encoder. This output is HIGH for one transmit character-clock period to indicate detection of a parity error in the character presented to the encoder.</p> <p>If a parity error is detected, the character in error is replaced with a C0.7 character to force a corresponding bad-character detection at the remote end of the link. This replacement takes place regardless of the encoded/un-encoded state of the interface.</p> <p>When BIST is enabled for the specific transmit channel, BIST progress is presented on this output. Once every 511 character times (plus a 16-character Word Sync Sequence when the receive channel is clocked by REFCLK, i.e., RXCKSEL = LOW), the TXPER signal pulses HIGH for one transmit-character clock period (if RXCKSEL = MID) or seventeen transmit-character clock periods (if RXCKSEL = LOW or HIGH) to indicate a complete pass through the BIST sequence. For RXCKSEL = LOW or HIGH, if TXMODE[1:0] = LL, then no Word Sync Sequence is sent in BIST, and TXPER pulses HIGH for one transmit-character clock period.</p> <p>This output also provides an indication of a phase-align buffer underflow/overflow condition. When the phase-align buffer is enabled (TXCKSEL ≠ LOW, or TXCKSEL = LOW and TXRATE = HIGH), and an underflow/overflow condition is detected, TXPER is asserted and remains asserted until either an atomic Word Sync Sequence is transmitted or TXRST is sampled LOW to recenter the phase-align buffer.</p>
TXCT[1:0]	LVTTL input, synchronous, sampled by TXCLK↑ or REFCLK↑ ^[3]	<p>Transmit control. These inputs are captured on the rising edge of the transmit interface clock as selected by TXCKSEL, and are passed to the encoder or transmit shifter. They identify how the TXD[7:0] characters are interpreted. When the encoder is enabled, these inputs determine if the TXD[7:0] character is encoded as data, a special character code, a K28.5 fill character or a Word Sync Sequence. When the encoder is bypassed, these inputs are interpreted as data bits. See Table 1 for details.</p>
TXD[7:0]	LVTTL input, synchronous, sampled by TXCLK↑ or REFCLK↑ ^[3]	<p>Transmit data inputs. These inputs are captured on the rising edge of the transmit interface clock as selected by TXCKSEL, and passed to the encoder or transmit shifter.</p> <p>When the encoder is enabled (TXMODE[1] ≠ LOW), TXD[7:0] specify the specific data or command character to be sent. When the encoder is bypassed, these inputs are interpreted as data bits of the 10-bit input character. See Table 1 for details.</p>
TXOP	LVTTL input, synchronous, internal pull-up, sampled by TXCLK↑ or REFCLK↑ ^[3]	<p>Transmit path odd parity. When parity checking is enabled (PARCTL ≠ LOW), the parity captured at this input is XORed with the data on the TXD bus (and sometimes TXCT[1:0]) to verify the integrity of the captured character. See Table 2 for details.</p>
SCSEL	LVTTL input, synchronous, internal pull-down, sampled by TXCLK↑ or REFCLK↑ ^[3]	<p>Special character select. Used in some transmit modes along with TXCTx[1:0] to encode special characters or to initiate a Word Sync Sequence. When the transmit path is configured to select TXCLK to clock the input register (TXCKSEL = MID or HIGH), SCSEL is captured relative to TXCLK↑.</p>

Note

- When REFCLK is configured for half-rate operation (TXRATE = HIGH), this input is sampled (or the outputs change) relative to both the rising and falling edges of REFCLK.

Pin Descriptions (continued)

CYP(V)15G0101DXB single-channel HOTLink II

Pin Name	I/O Characteristics	Signal Description
TXRST	LVTTL input, asynchronous, internal pull-up, sampled by REFCLK↑ ^[4]	<p>Transmit clock phase reset. Active LOW. When sampled LOW, the transmit phase-align buffer is allowed to adjust its data-transfer timing (relative to the selected input clock) to allow clean transfer of data from the input register to the encoder or transmit shifter. When TXRST is sampled HIGH, the internal phase relationship between the TXCLK and the internal character-rate clock is fixed and the device operates normally.</p> <p>When configured for half-rate REFCLK sampling of the transmit character stream (TXCKSEL = LOW and TXRATE = HIGH), assertion of TXRST is only used to clear phase-align buffer faults caused by highly asymmetric reference clock periods or reference clocks with excessive cycle-to-cycle jitter. During this alignment period, one or more characters may be added to or lost from all the associated transmit paths as the transmit phase-align buffers are adjusted. TXRST must be sampled LOW by a minimum of two consecutive rising edges of REFCLK to ensure the reset operation is initiated correctly on all channels. This input is ignored when both TXCKSEL and TXRATE are LOW, since the phase align buffer is bypassed. In all other configurations, TXRST should be asserted during device initialization to ensure proper operation of the phase-align buffer. TXRST should be asserted after the assertion and deassertion of TRSTZ, after the presence of a valid TXCLK and after allowing enough time for the TXPLL to lock to the reference clock (as specified by parameter t_{TXLOCK}).</p>
Transmit Path Clock and Clock Control		
TXCKSEL	3-level select static control input ^[5]	<p>Transmit clock select. Selects the clock source used to write data into the transmit input register of the transmit channel. When LOW, the input register is clocked by REFCLK↑.^[4] When HIGH or MID, TXCLK↑ is the input register clock for TXD[7:0] and TXCT[1:0].</p> <p>When TXRATE=HIGH, configuring TXCKSEL = HIGH or MID is an invalid mode of operation.</p>
TXCLKO±	LVTTL output	<p>Transmit clock output. This true and complement output clock is synthesized by the transmit PLL and is synchronous to the internal transmit character clock. It has the same frequency as REFCLK (when TXRATE = LOW), or twice the frequency of REFCLK (when TXRATE = HIGH). This output clock has no direct phase relationship to REFCLK.</p>
TXRATE	LVTTL input, static control input, internal pull-down	<p>Transmit PLL clock rate select. When TXRATE = HIGH, the transmit PLL multiplies REFCLK by 20 to generate the serial bit-rate clock.</p> <p>When TXRATE = LOW, the transmit PLL multiplies REFCLK by 10 to generate the serial bit-rate clock. See Table 9 for a list of operating serial rates.</p> <p>When REFCLK is selected to clock the receive parallel interfaces (RXCKSEL = LOW), the TXRATE input also determines if the clocks on the RXCLK± and RXCLKC+ outputs are full or half-rate. When TXRATE = HIGH (REFCLK is half-rate), the RXCLK± and RXCLKC+ output clocks are also half-rate clocks and follow the frequency and duty cycle of the REFCLK input. When TXRATE = LOW (REFCLK is full-rate), the RXCLK± and RXCLKC+ output clocks are also full-rate clocks and follow the frequency and duty cycle of the REFCLK input.</p> <p>When TXRATE=HIGH, configuring TXCKSEL = HIGH or MID is an invalid mode of operation.</p>
TXCLK	LVTTL clock input, internal pull-down	<p>Transmit path input clock. This clock must be frequency-coherent to TXCLKO±, but may be offset in phase. The internal operating phase of the input clock (relative to REFCLK or TXCLKO+) is adjusted when TXRST = LOW and locked when TXRST = HIGH.</p>
Transmit Path Mode Control		
TXMODE[1:0]	3-level select ^[5] static control inputs	<p>Transmit operating mode. These inputs are interpreted to select one of nine operating modes of the transmit path. See Table 3 for a list of operating modes.</p>

Notes

- When REFCLK is configured for half-rate operation (TXRATE = HIGH), this input is sampled (or the outputs change) relative to both the rising and falling edges of REFCLK.
- 3-level select inputs are used for static configuration. They are ternary (not binary) inputs that make use of non-standard logic levels of LOW, MID, and HIGH. The LOW level is usually implemented by direct connection to V_{SS} (ground). The HIGH level is usually implemented by direct connection to V_{CC} (power). When not connected or allowed to float, a 3-level select input will self-bias to the MID level.

Pin Descriptions *(continued)*

CYP(V)15G0101DXB single-channel HOTLink II

Pin Name	I/O Characteristics	Signal Description
Receive Path Data Signals		
RXD[7:0]	LVTTTL output, synchronous to the RXCLK \uparrow output (or REFCLK \uparrow input ^[6]) when RXCKSEL = LOW)	<p>Parallel data output. These outputs change following the rising edge of the selected receive interface clock.</p> <p>When the decoder is enabled (DECMODE = HIGH or MID), these outputs represent either received data or a special character. The status of the received data is represented by the values of RXST[2:0].</p> <p>When the decoder is bypassed (DECMODE = LOW), RXD[7:0] become the higher order bits of the 10-bit received character. See Table 13 for details.</p>
RXST[2:0]	LVTTTL output, synchronous to the RXCLK \uparrow output (or REFCLK \uparrow input ^[6]) when RXCKSEL = LOW)	<p>Parallel status output. These outputs change following the rising edge of the selected receive interface clock.</p> <p>When the decoder is bypassed (DECMODE = LOW), RXST[1:0] become the two low-order bits of the 10-bit received character, while RXST[2] = HIGH indicates the presence of a comma character in the output register.</p> <p>When the decoder is enabled (DECMODE = HIGH or MID), RXST[2:0] provide status of the received signal. See Table 16 for a list of receive character status.</p>
RXOP	3-state, LVTTTL output, synchronous to the RXCLK \uparrow output (or REFCLK \uparrow input ^[6]) when RXCKSEL = LOW)	<p>Receive path odd parity. When parity generation is enabled (PARCTL \neq LOW), the parity output is valid for the data on the RXD bus bits.</p> <p>When parity generation is disabled (PARCTL = LOW), this output driver is disabled (high Z).</p>
Receive Path Clock and Clock Control		
RXCLK \pm	3-state, LVTTTL output clock	<p>Receive character clock output. When configured such that the output data path is clocked by the recovered clock (RXCKSEL = MID), these true and complement clocks are the receive interface clocks which are used to control timing of output data (RXD[7:0], RXST[2:0] and RXOP). This clock is output continuously at either the dual-character rate (1/20th the serial bit-rate) or character rate (1/10th the serial bit-rate) of the data being received, as selected by RXRATE.</p> <p>When configured such that the output data path is clocked by REFCLK instead of recovered clock (RXCKSEL = LOW), the RXCLK\pm output drivers present a buffered and delayed form of REFCLK. In this mode, RXCLK\pm and RXCLKC+ are buffered forms of REFCLK that are slightly different in phase, but follow the frequency and duty cycle of REFCLK. This phase difference allows the user to select the optimal set-up/hold timing for their specific interface.</p>
RXCLKC+	3-state, LVTTTL output	<p>Delayed REFCLK+ when RXCKSEL = LOW. Delayed form of REFCLK+, used for transfer of output data to a host system. This output is only enabled when the receive parallel interface is configured to present data relative to REFCLK (RXCKSEL = LOW). When RXCKSEL = LOW, the RXCLKC+ follows the frequency and duty cycle of REFCLK+.</p>
RXRATE	LVTTTL input static control input, internal pull-down	<p>Receive clock rate select. When LOW, the RXCLK\pm recovered clock outputs are complementary clocks operating at the recovered character rate. Data for the receive channel should be latched on either the rising edge of RXCLK+ or falling edge of RXCLK-.</p> <p>When HIGH, the RXCLK\pm recovered clock outputs are complementary clocks operating at half the character rate. Data for the receive channel should be latched alternately on the rising edge of RXCLK+ and RXCLK-.</p> <p>When the output register is operated with REFCLK clocking (RXCKSEL = LOW), RXRATE is not interpreted and RXCLK\pm follows the frequency and duty cycle of REFCLK.</p>
RFEN	LVTTTL input, asynchronous, internal pull-down	<p>Reframe enable. Active HIGH. When HIGH, the Framer in the receive channel is enabled to frame per the presently enabled framing mode and selected framing character.</p>

Note

6. When REFCLK is configured for half-rate operation (TXRATE = HIGH), this input is sampled (or the outputs change) relative to both the rising and falling edges of REFCLK.

Pin Descriptions *(continued)*

CYP(V)15G0101DXB single-channel HOTLink II

Pin Name	I/O Characteristics	Signal Description
RXMODE	3-level select ^[7] static control input	Receive operating mode. This input selects one of two RXST channel status reporting modes and is only interpreted when the decoder is enabled (DECMODE ≠ LOW). See Table 19 for details.
FRAMCHAR	3-level select ^[7] static control input	Framing character select. Used to select the character or portion of a character used for character framing of the received data streams. When MID, the framer looks for both positive and negative disparity versions of the eight-bit comma character. When HIGH, the framer looks for both positive and negative disparity versions of the K28.5 character. Configuring FRAMCHAR = LOW is reserved for component test.
RFMODE	3-level select static control input ^[7]	Reframe mode select. Used to select the type of character framing used to adjust the character boundaries (based on detection of one or more framing characters in the data stream. This signal operates in conjunction with the type of framing character selected. When LOW, the low-latency framer is selected. This will frame on each occurrence of the selected framing character(s) in the received data stream. This mode of framing stretches the recovered character-rate clock for one or multiple cycles to align that clock with the recovered data. When MID, the Cypress-mode multi-byte parallel framer is selected. This requires a pair of the selected framing character(s), on identical 10-bit boundaries, within a span of 50 bits (five characters), before the character boundaries are adjusted. The recovered character clock remains in the same phase regardless of character offset. When HIGH, the alternate-mode multi-byte parallel framer is selected. This requires detection of the selected framing character(s) in the received data stream, on identical 10-bit boundaries, on four directly adjacent characters. The recovered character clock remains in the same phase regardless of character offset.
PARCTL	3-level select static control input ^[7]	Parity check/Generate control. Used to control the parity check and generate functions. When LOW, parity checking is disabled, and the RXOP output is disabled (high Z). When MID, and the 8B/10B encoder and decoder are enabled (TXMODE[1] ≠ LOW, DECMODE ≠ LOW), TXD[7:0] inputs are checked (along with TXOP) for valid ODD parity, and ODD parity is generated for the RXD[7:0] outputs and presented on RXOP. When the 8B/10B encoder and decoder are disabled (TXMODE[1] = LOW, DECMODE = LOW), the TXD[7:0] and TXCT[1:0] inputs are checked (along with TXOP) for valid ODD parity, and ODD parity is generated for the RXD[7:0] and RXST[1:0] outputs and presented on RXOP. When HIGH, parity generation and checking are enabled. The TXD[7:0] and TXCT[1:0] inputs are checked (along with TXOP) for valid ODD parity, and ODD parity is generated for the RXD[7:0] and RXST[2:0] outputs and presented on RXOP. See Table 2 and Table 15 for details.
DECMODE	3-level select static control input ^[7]	Decoder mode select. When LOW, the decoder is bypassed and raw 10-bit characters are passed to the output register. When the decoder is bypassed, RXCKSEL must be MID. When MID, the Cypress Decoder table for special code characters is used. When HIGH, the alternate Decoder table for special code characters is used. See Table 21 for a list of the special codes supported in both encoded modes.
RXCKSEL	3-level select ^[7] static control input	Receive clock mode. Selects the receive clock source used to transfer data to the output registers and configures the elasticity buffer in the receive path. When LOW, the output register is clocked by REFCLK. RXCLK± and RXCLKC+ present buffered and delayed forms of REFCLK. When MID, the RXCLK± output follows the recovered clock as selected by RXRATE and the elasticity buffer is bypassed. When the 10B/8B decoder and elasticity buffer are bypassed (DECMODE=LOW), RXCKSEL must be MID. Configuring RXCKSEL = HIGH is an invalid mode of operation.

Note

7. 3-level select inputs are used for static configuration. They are ternary (not binary) inputs that make use of non-standard logic levels of LOW, MID, and HIGH. The LOW level is usually implemented by direct connection to V_{SS} (ground). The HIGH level is usually implemented by direct connection to V_{CC} (power). When not connected or allowed to float, a 3-level select input will self-bias to the MID level.

Pin Descriptions *(continued)*

CYP(V)15G0101DXB single-channel HOTLink II

Pin Name	I/O Characteristics	Signal Description
Device Control Signals		
SPDSEL	3-level select, ^[8] static control input	Serial rate select. This input specifies the operating bit-rate range of both transmit and receive PLLs. LOW = 195–400 MBaud, MID = 400–800 MBaud, HIGH = 800–1500 MBaud. When SPDSEL=LOW, setting TXRATE=HIGH (half-rate reference clock) is invalid.
REFCLK±	Differential LVPECL or single-ended LVTTTL input clock	Reference clock. This clock input is used as the timing reference for the transmit PLL. It is also used as the centering frequency of the range controller block of the receive CDR PLLs. This input clock may also be selected to clock the transmit and receive parallel interfaces. When driven by a single-ended LVCMOS or LVTTTL clock source, the clock source may be connected to either the true or complement REFCLK input, with the alternate REFCLK input left open (floating). When driven by an LVPECL clock source, the clock must be a differential clock, using both inputs. When TXCKSEL = LOW, REFCLK is also used as the clock for the parallel transmit data (input) interface. When RXCKSEL = LOW and decoder is enabled, the elasticity buffer is enabled and REFCLK is used as the clock source for the parallel receive data (output) interface. If the elasticity buffer is used, framing characters will be inserted or deleted to/from the data stream to compensate for frequency differences between the reference clock and recovered clock. When addition happens, a K28.5 will be appended immediately after a framing character is detected in the elasticity buffer. When deletion happens, a framing character will be removed from the data stream when detected in the elasticity buffer.
TRSTZ	LVTTTL input, internal pull-up	Device reset. Active LOW. Initializes all state machines and counters in the device. When sampled LOW by the rising edge of REFCLK, this input resets the internal state machines and sets the elasticity buffer pointers to a nominal offset. When the reset is removed (TRSTZ sampled HIGH by REFCLK↑), the status and data outputs will become deterministic in less than 16 REFCLK cycles. The BISTLE, OELE, and RXLE latches are reset by TRSTZ. If the elasticity buffer or the phase-align buffer are used, TRSTZ should be applied after power-up to initialize the internal pointers into these memory arrays.
Analog I/O and Control		
OUT1±	CML differential output	Primary differential serial data outputs. These PECL-compatible CML outputs (+3.3 V referenced) are capable of driving terminated transmission lines or standard fiber-optic transmitter modules.
OUT2±	CML differential output	Secondary differential serial data outputs. These PECL-compatible CML outputs (+3.3 V referenced) are capable of driving terminated transmission lines or standard fiber-optic transmitter modules.
IN1±	LVPECL differential Input, with internal DC restoration	Primary differential serial data inputs. These inputs accept the serial data stream for deserialization and decoding. The IN1± serial stream is passed to the receiver clock and data recovery (CDR) circuit to extract the data content when INSEL = HIGH.
IN2±	LVPECL differential input, with internal DC restoration	Secondary differential serial data inputs. These inputs accept the serial data stream for deserialization and decoding. The IN2± serial stream is passed to the receiver CDR circuit to extract the data content when INSEL = LOW.
INSEL	LVTTTL input, asynchronous	Receive input selector. Determines which external serial bit stream is passed to the receiver CDR. When HIGH, the IN1± input is selected. When LOW, the IN2± input is selected.
SDASEL	3-level select, ^[8] static control input	Signal detect amplitude level select. Allows selection of one of three predefined amplitude trip points for a valid signal indication, as listed in Table 10 .
LPEN	LVTTTL input, asynchronous, internal pull-down	Loop-back-enable. Active HIGH. When asserted (HIGH), the transmit serial data is internally routed to the receiver CDR circuit. All enabled serial drivers are forced to differential logic “1.” All serial data inputs are ignored.

8. 3-level select inputs are used for static configuration. They are ternary (not binary) inputs that make use of non-standard logic levels of LOW, MID, and HIGH. The LOW level is usually implemented by direct connection to V_{SS} (ground). The HIGH level is usually implemented by direct connection to V_{CC} (power). When not connected or allowed to float, a 3-level select input will self-bias to the MID level.

Pin Descriptions (continued)

CYP(V)15G0101DXB single-channel HOTLink II

Pin Name	I/O Characteristics	Signal Description
OELE	LVTTL input, asynchronous, internal pull-up	Serial driver output enable latch enable. Active HIGH. When OELE = HIGH, the signals on the BOE[1:0] inputs directly control the OUT _{x±} differential drivers. When the BOE[x] input is HIGH, the associated OUT _{x±} differential driver is enabled. When the BOE[x] input is LOW, the associated OUT _{x±} differential driver is powered down. When OELE returns LOW, the last values present on BOE[1:0] are captured in the internal output enable latch. The specific mapping of BOE[1:0] signals to transmit output enables is listed in Table 14 . If the device is reset (TRSTZ is sampled LOW), the latch is reset to disable both outputs.
BISTLE	LVTTL input, asynchronous, internal pull-up	Transmit and receive BIST latch enable. Active HIGH. When BISTLE = HIGH, the signals on the BOE[1:0] inputs directly control the transmit and receive BIST enables. When the BOE[x] input is LOW, the associated transmit or receive channel is configured to generate or compare the BIST sequence. When the BOE[x] input is HIGH, the associated transmit or receive channel is configured for normal data transmission or reception. When BISTLE returns LOW, the last values present on BOE[1:0] are captured in the internal BIST enable latch. The specific mapping of BOE[1:0] signals to transmit and receive BIST enables is listed in Table 14 . When the latch is closed, if the device is reset (TRSTZ is sampled LOW), the latch is reset to disable BIST on both the transmit and receive channels.
RXLE	LVTTL input, asynchronous, internal pull-up	Receive channel power-control latch enable. Active HIGH. When RXLE = HIGH, the signal on the BOE[0] input directly controls the power enable for the receive PLL and analog logic. When the BOE[0] input is HIGH, the receive channel PLL and analog logic are active. When the BOE[0] input is LOW, the receive channel PLL and analog logic are placed in a non-functional power saving mode. When RXLE returns LOW, the last value present on BOE[0] is captured in the internal RX PLL enable latch. The specific mapping of BOE[1:0] signals to the receive channel enable is listed in Table 14 . When the latch is closed, if the device is reset (TRSTZ is sampled LOW), the latch is reset to disable the receive channel.
BOE[1:0]	LVTTL input, asynchronous, internal pull-up	BIST, serial output, and receive channel enables. These inputs are passed to and through the output enable latch when OELE = HIGH, and captured in this latch when OELE returns LOW. These inputs are passed to and through the BIST enable latch when BISTLE = HIGH, and captured in this latch when BISTLE returns LOW. These inputs are passed to and through the receive channel enable latch when RXLE = HIGH, and captured in this latch when RXLE returns LOW.
LFI	LVTTL output, asynchronous	Link fault indication output. Active LOW. LFI is the logical OR of four internal conditions: <ol style="list-style-type: none"> 1. Received serial data frequency outside expected range 2. Analog amplitude below expected levels 3. Transition density lower than expected 4. Receive channel disabled.
JTAG Interface		
TMS	LVTTL input, internal pull-up	Test mode select. Used to control access to the JTAG test modes. If maintained high for ≥ 5 TCLK cycles, the JTAG test controller is reset. The TAP controller is also reset automatically upon application of power to the device.
TCLK	LVTTL input, internal pull-down	JTAG test clock.
TDO	Three-state LVTTL output	Test data out. JTAG data output buffer which is high Z while JTAG test mode is not selected.
TDI	LVTTL input, internal pull-up	Test data in. JTAG data input port.
Power		
V _{CC}		+3.3 V power
GND		Signal and power ground for all internal circuits.

CYP(V)15G0101DXB HOTLink II Operation

The CYP(V)15G0101DXB is a highly configurable device designed to support reliable transfer of large quantities of data using high-speed serial links from a single source to one or more destinations.

CYP(V)15G0101DXB Transmit Data Path

Operating Modes

The transmit path of the CYP(V)15G0101DXB supports a single character-wide data path. This data path is used in multiple operating modes as controlled by the TXMODE[1:0] inputs.

Input Register

The bits in the input register support different assignments, based on if the character is unencoded, encoded with two control bits, or encoded with three control bits. These assignments are shown in Table 1.

Table 1. Input Register Bit Assignments^[9]

Signal Name	Unencoded (Encoder Bypassed)	Encoded (Encoder Enabled)	
		Two-bit Control	Three-bit Control
TXD[0] (LSB)	DIN[0]	TXD[0]	TXD[0]
TXD[1]	DIN[1]	TXD[1]	TXD[1]
TXD[2]	DIN[2]	TXD[2]	TXD[2]
TXD[3]	DIN[3]	TXD[3]	TXD[3]
TXD[4]	DIN[4]	TXD[4]	TXD[4]
TXD[5]	DIN[5]	TXD[5]	TXD[5]
TXD[6]	DIN[6]	TXD[6]	TXD[6]
TXD[7]	DIN[7]	TXD[7]	TXD[7]
TXCT[0]	DIN[8]	TXCT[0]	TXCT[0]
TXCT[1] (MSB)	DIN[9]	TXCT[1]	TXCT[1]
SCSEL	N/A	N/A	SCSEL

The input register captures a minimum of eight data bits and two control bits on each input clock cycle. When the encoder is bypassed, the TXCT[1:0] control bits are part of the pre-encoded 10-bit data character.

When the encoder is enabled (TXMODE[1] ≠ LOW), the TXCT[1:0] bits are interpreted along with the TXD[7:0] character to generate the specific 10-bit transmission character. When TXMODE[0] ≠ HIGH, an additional special character select (SCSEL) input is also captured and interpreted. This SCSEL input is used to modify the encoding of the characters.

Phase-Align Buffer

Data from the input register is passed either to the encoder or to the phase-align buffer. When the transmit path is operated synchronous to REFCLK↑ (TXCKSEL = LOW and TXRATE = LOW), the phase-align buffer is bypassed and data is passed directly to the parity check and encoder block to reduce latency.

When an input register clock with an uncontrolled phase relationship to REFCLK is selected (TXCKSEL ≠ LOW) or if data is captured on both edges of REFCLK (TXRATE = HIGH), the phase-align buffer is enabled. This buffer is used to absorb clock phase differences between the presently selected input clock and the internal character clock.

Initialization of the phase-align buffer takes place when the TXRST input is sampled LOW by two consecutive rising edges of REFCLK. When TXRST is returned HIGH, the present input clock phase relative to REFCLK↑ is set. TXRST is an asynchronous input, but is sampled internally to synchronize it to the internal transmit path state machine.

Once set, the input clock is allowed to skew in time up to half a character period in either direction relative to REFCLK↑; that is ±180°. This time shift allows the delay path of the character clock (relative to REFCLK↑) to change due to operating voltage and temperature, while not affecting the design operation.

If the phase offset, between the initialized location of the input clock and REFCLK↑, exceeds the skew handling capabilities of the phase-align buffer, an error is reported on the TXPER output. This output indicates a continuous error until the phase-align buffer is reset. While the error remains active, the transmitter outputs a continuous C0.7 character to indicate to the remote receiver that an error condition is present in the link.

In specific transmit modes, it is also possible to reset the phase-align buffer with minimal disruption of the serial data stream. When the transmit interface is configured for generation of atomic Word Sync Sequences (TXMODE[1] = MID) and a phase-align buffer error is present, the transmission of a Word Sync Sequence will recenter the phase-align buffer and clear the error condition.^[10]

Parity Support

In addition to the ten data and control bits that are captured at the transmit input register, a TXOP input is also available. This allows the CYP(V)15G0101DXB to support ODD parity checking. Parity checking is available for all operating modes (including encoder bypass). The specific mode of parity checking is controlled by the PARCTL input, and operates per Table 2.

When PARCTL = MID (open) and the encoder is enabled (TXMODE[1] ≠ LOW), only the TXD[7:0] data bits are checked for ODD parity along with the TXOP bit. When PARCTL = HIGH with the encoder enabled (or MID with the encoder bypassed), the TXD[7:0] and TXCT[1:0] inputs are checked for ODD parity along with the TXOP bit. When PARCTL = LOW, parity checking is disabled.

Notes

9. The TXOP input is also captured in the input register, but its interpretation is under the separate control of PARCTL.

10. One or more K28.5 characters may be added or lost from the data stream during this reset operation. When used with non-Cypress devices that require a complete 16-character Word Sync Sequence for proper receive elasticity buffer alignment, it is recommended that the sequence be followed by a second Word Sync Sequence to ensure proper operation.

When parity checking and the encoder are both enabled (TXMODE[1] ≠ LOW), the detection of a parity error causes a C0.7 character of proper disparity to be passed to the transmit shifter. When the encoder is bypassed (TXMODE[1] = LOW), detection of a parity error causes a positive disparity version of a C0.7 transmission character to be passed to the transmit shifter.

Table 2. Input Register Bits Checked for Parity^[12]

Signal Name	Transmit Parity Check Mode (PARCTL)			HIGH
	LOW	MID		
		TXMODE[1] = LOW	TXMODE[1] ≠ LOW	
TXD[0]		X ^[11]	X	X
TXD[1]		X	X	X
TXD[2]		X	X	X
TXD[3]		X	X	X
TXD[4]		X	X	X
TXD[5]		X	X	X
TXD[6]		X	X	X
TXD[7]		X	X	X
TXCT[0]		X		X
TXCT[1]		X		X
TXOP		X	X	X

Encoder

The character, received from the input register or phase-align buffer and parity check logic, is then passed to the encoder logic. This block interprets each character and any control bits, and outputs a 10-bit transmission character.

Depending on the configured operating mode, the generated transmission character may be

- the 10-bit pre-encoded character accepted in the input register
- the 10-bit equivalent of the eight-bit data character accepted in the input register
- the 10-bit equivalent of the eight-bit special character code accepted in the input register
- the 10-bit equivalent of the C0.7 SVS character if parity checking was enabled and a parity error was detected
- the 10-bit equivalent of the C0.7 SVS character if a phase-align buffer overflow or underflow error is present
- a character that is part of the 511-character BIST sequence
- a K28.5 character generated as an individual character or as part of the 16-character Word Sync Sequence.

The selection of the specific characters generated are controlled by the TXMODE[1:0], SCSEL, TXCT[1:0], and TXD[7:0] inputs for each character.

Notes

11. Bits marked as X are XORed together. Result must be a logic-1 for parity to be valid.
 12. Transmit path parity errors are reported on the TPER output.

Data Encoding

Raw data, as received directly from the transmit input register, is seldom in a form suitable for transmission across a serial link. The characters must usually be processed or transformed to guarantee

- a minimum transition density (to allow the serial receive PLL to extract a clock from the data stream)
- a DC-balance in the signaling (to prevent baseline wander)
- run-length limits in the serial data (to limit the bandwidth of the link)
- the remote receiver a way of determining the correct character boundaries (framing).

When the encoder is enabled (TXMODE[1] ≠ LOW), the characters to be transmitted are converted from data or special character codes to 10-bit transmission characters (as selected by the TXCT[1:0] and SCSEL inputs), using an integrated 8B/10B encoder. When directed to encode the character as a special character code, it is encoded using the special character encoding rules listed in Table 21. When directed to encode the character as a data character, it is encoded using the data character encoding rules in Table 20.

The 8B/10B encoder is standards compliant with ANSI/NCITS ASC X3.230-1994 (fibre channel), IEEE 802.3z (gigabit ethernet), the IBM® ESCON® and FICON™, and digital video broadcast (DVB-ASI) standards for data transport.

Many of the special character codes listed in Table 21 may be generated by more than one input character. The CYP(V)15G0101DXB is designed to support two independent (but non-overlapping) special character code tables. This allows the CYP(V)15G0101DXB to operate in mixed environments with other Cypress HOTLink devices using the enhanced Cypress command code set, and the reduced command sets of other non-Cypress devices. Even when used in an environment that normally uses non-Cypress special character codes, the selective use of Cypress command codes can permit operation where running disparity and error handling must be managed.

Following conversion of each input character from eight bits to a 10-bit transmission character, it is passed to the transmit shifter and is shifted out LSB first, as required by ANSI and IEEE standards for 8B/10B coded serial data streams.

Transmit Modes

The operating mode of the transmit path is set through the TXMODE[1:0] inputs. These 3-level select inputs allow one of nine transmit modes to be selected. The transmit modes are listed in Table 3.

The encoded modes (TX modes 3 through 8) support multiple encoding tables. These encoding tables vary by the specific combinations of SCSEL, TXCT[1], and TXCT[0] that are used to control the generation of data and control characters. These multiple encoding forms allow maximum flexibility in interfacing to legacy applications, while also supporting numerous extensions in capabilities. TX Mode 0—encoder bypass

When the encoder is bypassed, the character captured from the TXD[7:0] and TXCT[1:0] inputs is passed directly to the transmit shifter without modification. If parity checking is enabled (PARCTL ≠ LOW) and a parity error is detected, the 10-bit character is replaced with the 1001111000 pattern (+C0.7 character) regardless of the running disparity of the previous character.

With the encoder bypassed, the TXCT[1:0] inputs are considered part of the data character and do not perform a control function that would otherwise modify the interpretation of the TXD[7:0] bits. The bit usage and mapping of these control bits when the encoder is bypassed is shown in Table 4.

In encoder bypass mode, the SCSEL input is ignored. All clocking modes interpret the data in the same way.

Table 3. Transmit Operating Modes

TX Mode		Operating Mode		
Mode Number	TXMODE [1:0]	Word Sync Sequence Support	SCSEL Control	TXCT Function
0	LL	None	None	Encoder bypass
1	LM	None	None	Reserved for test
2	LH	None	None	Reserved for test
3	ML	Atomic	Special Character	Encoder control
4	MM	Atomic	Word Sync	Encoder control
5	MH	Atomic	None	Encoder control
6	HL	Interruptible	Special Character	Encoder control
7	HM	Interruptible	Word Sync	Encoder control
8	HH	Interruptible	None	Encoder control

Table 4. Encoder Bypass Mode (TXMODE[1:0] = LL)

Signal Name	Bus Weight	10B Name
TXD[0] (LSB) ^[13]	2 ⁰	a
TXD[1]	2 ¹	b
TXD[2]	2 ²	c
TXD[3]	2 ³	d
TXD[4]	2 ⁴	e
TXD[5]	2 ⁵	i
TXD[6]	2 ⁶	f
TXD[7]	2 ⁷	g
TXCT[0]	2 ⁸	h
TXCT[1] (MSB)	2 ⁹	j

Note
13. LSB is shifted out first.

TX Modes 1 and 2—Factory Test Modes

These modes enable specific factory test configurations. They are not considered normal operating modes of the device. Entry or configuration into these test modes will not damage the device.

TX Mode 3—Atomic Word Sync and SCSEL Control of Special Codes

When configured in TX Mode 3, the SCSEL input is captured along with the TXCT[1:0] data control inputs. These bits combine to control the interpretation of the TXD[7:0] bits and the characters generated by them. These bits are interpreted as listed in Table 5.

Table 5. TX Modes 3 and 6 Encoding

SCSEL	TXCT[1]	TXCT[0]	Characters Generated
X	X	0	Encoded data character
0	0	1	K28.5 fill character
1	0	1	Special character code
X	1	1	16-character Word Sync Sequence

When TXCKSEL = MID or HIGH, the transmit channel captures data into its input register using the TXCLK clock.

Word Sync Sequence

When TXCT[1:0] = 11, a 16-character sequence of K28.5 characters, known as a Word Sync Sequence, is generated on the transmit channel. This sequence of K28.5 characters may start with either a positive or negative disparity K28.5 (as determined by the current running disparity and the 8B/10B coding rules). The disparity of the second and third K28.5 characters in this sequence are reversed from what normal 8B/10B coding rules would generate. The remaining K28.5 characters in the sequence follow all 8B/10B coding rules. The disparity of the generated K28.5 characters in this sequence follow a pattern of either + + - - + - + - + - + - + - or - - + + - + - + - + - + - + -.

When TXMODE[1] = MID (open, TX modes 3, 4 and 5), the generation of this character sequence is an atomic (non-interruptible) operation. Once it has been successfully started, it cannot be stopped until all 16 characters have been generated. The content of the input register is ignored for the duration of this 16-character sequence. At the end of this sequence, if the TXCT[1:0] = 11 condition is sampled again, the sequence restarts and remains uninterrupted for the following 15 character clocks.

If parity checking is enabled, the character used to start the Word Sync Sequence must also have correct ODD parity. This is true even though the contents of the TXD[7:0] bits do not directly control the generation of characters during the Word Sync Sequence. Once the sequence is started, parity is not checked on the following 15 characters in the Word Sync Sequence.

When TXMODE[1] = HIGH (TX modes 6, 7, and 8), the generation of the Word Sync Sequence becomes an interruptible operation. In TX Mode 6, this sequence is started as soon as the TXCT[1:0] = 11 condition is detected on the channel. In order for the sequence to continue, the TXCT[1:0] inputs must be sampled as 00 for the remaining 15 characters of the sequence. If at any time a sample period exists where TXCT[1:0] ≠ 00, the Word Sync Sequence is terminated, and a character representing the data and control bits is generated by the encoder. This resets the Word Sync Sequence state machine such that it will start at the beginning of the sequence at the next occurrence of TXCT[1:0] = 11.

When parity checking is enabled and TXMODE[1] = HIGH, all characters (including those in the middle of a Word Sync Sequence) must have correct parity. The detection of a character with incorrect parity during a Word Sync Sequence (regardless of the state of TXCT[1:0]) will interrupt that sequence and force generation of a C0.7 SVS character. Any interruption of the Word Sync Sequence causes the sequence to terminate.

When TXCKSEL = LOW, the input register for the transmit channel is clocked by REFCLK.^[14] When TXCKSEL = HIGH or MID, the input register for the transmit channel is clocked with TXCLK↑.

TX Mode 4—Atomic Word Sync and SCSEL Control of Word Sync Sequence Generation

When configured in TX Mode 4, the SCSEL input is captured along with the TXCT[1:0] data control inputs. These bits combine to control the interpretation of the TXD[7:0] bits and the characters generated by them. These bits are interpreted as listed in Table 6.

Table 6. TX Modes 4 and 7 Encoding

SCSEL	TXCT[1]	TXCT[0]	Characters Generated
X	X	0	Encoded data character
0	0	1	K28.5 fill character
0	1	1	Special character code
1	X	1	16-character Word Sync Sequence

TX Mode 4 also supports an Atomic Word Sync Sequence. Unlike TX Mode 3, this sequence is started when both SCSEL and TXCT[0] are sampled HIGH. With the exception of the combination of control bits used to initiate the sequence, the generation and operation of this Word Sync Sequence is the same as that documented for TX Mode 3.

TX Mode 5—Atomic Word Sync, No SCSEL

When configured in TX Mode 5, the SCSEL signal is not used. The TXCT[1:0] inputs control the characters generated by the channel. The specific characters generated by these bits are listed in Table 7.

Table 7. TX Modes 5 and 8 Encoding

SCSEL	TXCT[1]	TXCT[0]	Characters Generated
X	0	0	Encoded data character
X	0	1	K28.5 fill character
X	1	0	Special character code
X	1	1	16-character Word Sync Sequence

TX Mode 5 also has the capability of generating an Atomic Word Sync Sequence. For the sequence to be started, the TXCT[1:0] inputs must both be sampled HIGH. The generation and operation of this Word Sync Sequence is the same as that documented for TX Mode 3.

Transmit BIST

The transmit channel contains an internal pattern generator that can be used to validate both device and link operation. This generator is enabled by the BOE[1] signal, as listed in Table 8 (when the BISTLE latch enable input is HIGH). When enabled, a register in the transmit channel becomes a signature pattern generator by logically converting to a linear feedback shift register (LFSR). This LFSR generates a 511-character sequence that includes all data and special character codes, including the explicit violation symbols. This provides a predictable yet pseudo-random sequence that can be matched to an identical LFSR in the attached Receiver. If the receive channel is configured for REFCLK clocking (RXCKSEL = LOW), each pass is preceded by a 16-character Word Sync Sequence to allow elasticity buffer alignment and management of clock-frequency variations.

When the BISTLE signal is HIGH, if the BOE[1] input is LOW, the BIST generator in the transmit channel is enabled (and if BOE[0] = LOW the BIST checker in the receive channel is enabled). When BISTLE returns LOW, the values of the BOE[1:0] signals are captured in the BIST enable latch. These values remain in the BIST enable latch until BISTLE is returned high to open the latch again. A device reset (TRSTZ sampled LOW), also presets the BIST enable latch to disable BIST on both the transmit and receive channels.

All data and data-control information present at the TXD[7:0] and TXCT[1:0] inputs are ignored when BIST is active on the transmit channel.

Note

¹⁴ When REFCLK is configured for half-rate operation (TXRATE = HIGH), this input is sampled (or the outputs change) relative to both the rising and falling edges of REFCLK.

Serial Output Drivers

The serial interface output drivers use high-performance differential current mode logic (CML) to provide source-matched drivers for the transmission lines. These serial drivers accept data from the transmit shifter. These outputs have signal swings equivalent to that of standard PECL drivers, and are capable of driving AC-coupled optical modules or AC-coupled transmission lines.

When configured for local loop-back (LPEN = HIGH), the enabled serial drivers are configured to drive a static differential logic-1.

Each serial driver can be enabled or disabled through the BOE[1:0] inputs, as controlled by the OELE latch-enable signal. When OELE = HIGH, the signals present on the BOE[1:0] inputs are passed through the serial output enable latch to control the serial driver. The BOE[1:0] input with OUT1± and OUT2± driver is listed in Table 8.

Table 8. Output Enable, BIST, and Receive Channel Enable Signal Map

BOE Input	Output Controlled (OELE)	BIST Channel Enable (BISTLE)	Receive PLL Channel Enable (RXLE)
BOE[1]	OUT2±	Transmit	X
BOE[0]	OUT1±	Receive	Receive

When OELE = HIGH and BOE[x] = HIGH, the associated serial driver is enabled to drive any attached transmission line. When OELE = HIGH and BOE[x] = LOW, the associated driver is disabled and internally configured for minimum power dissipation. If both serial drivers for the channel are disabled, the internal logic for the transmit channel is also configured for lowest power operation. When OELE returns LOW, the values present on the BOE[1:0] inputs are latched in the output enable latch, and remain there until OELE returns HIGH to open the latch again. A device reset (TRSTZ sampled LOW) clears this latch and disables both serial drivers.

Note. When both serial output drivers are disabled and a driver is re-enabled, the data on the serial drivers may not meet all timing specifications for up to 200 µs.

Transmit PLL Clock Multiplier

The transmit PLL clock multiplier accepts a character-rate or half-character-rate external clock at the REFCLK input, and multiplies that clock by 10 or 20 (as selected by TXRATE) to generate a bit-rate clock for use by the transmit shifter. It also provides a character-rate clock used by the transmit path.

This clock multiplier PLL can accept a REFCLK input between 19.5 MHz and 150 MHz, however, this clock range is limited by the operating mode of the CYP(V)15G0101DXB clock multiplier (controlled by TXRATE) and by the level on the SPDSEL input.

When TXRATE=HIGH, configuring TXCKSEL = HIGH or MID is an invalid mode of operation.

SPDSEL is a 3-level select^[15] (ternary) input that selects one of three operating ranges for the serial data outputs and inputs. The operating serial signaling-rate and allowable range of REFCLK frequencies are listed in Table 9.

Table 9. Operating Speed Settings

SPDSEL	TXRATE	REFCLK Frequency (MHz)	Signaling Rate (Mbaud)
LOW	1	Reserved	195–400
	0	19.5–40	
MID (Open)	1	20–40	400–800
	0	40–80	
HIGH	1	40–75	800–1500
	0	80–150	

The REFCLK± input is a differential input with each input internally biased to 1.4 V. If the REFCLK+ input is connected to a TTL, LVTTTL, or LVCMOS clock source, the input signal is recognized when it passes through the internally biased reference point.

When both the REFCLK+ and REFCLK– inputs are connected, the clock source must be a differential clock. This can be either a differential LVPECL clock that is DC- or AC-coupled, or a differential LVTTTL or LVCMOS clock.

By connecting the REFCLK– input to an external voltage source or resistive voltage divider, it is possible to adjust the reference point of the REFCLK+ input for alternate logic levels. When doing so, it is necessary to ensure that the 0 V-differential crossing point remains within the parametric range supported by the input.

CYP(V)15G0101DXB Receive Data Path

Serial Line Receivers

Two differential line receivers, IN1± and IN2±, are available for accepting serial data streams. The active serial line receiver is selected using the INSEL input. Both serial line receivers have differential inputs, and can accommodate wire interconnect and filtering losses or transmission line attenuation greater than 16 dB. For normal operation, these inputs should receive a signal of at least $V_{DIFFS} > 100$ mV, or 200-mV peak-to-peak differential. Each line receiver can be DC- or AC-coupled to +3.3 V powered fiber-optic interface modules (any ECL/PECL logic family, not limited to 100 K PECL) or AC-coupled to +5 V-powered optical modules. The common-mode tolerance of the receivers accommodates a wide range of signal termination voltages. Each receiver provides internal DC-restoration, to the center of the receiver's common mode range, for AC-coupled signals.

Note

15. When REFCLK is configured for half-rate operation (TXRATE = HIGH), this input is sampled (or the outputs change) relative to both the rising and falling edges of REFCLK.

The local loop-back input (LPEN) allows the serial transmit data to be routed internally back to the clock and data recovery circuit. When configured for local loop-back, the transmit serial driver outputs are forced to output a differential logic-1. This prevents local diagnostic patterns from being broadcast to attached remote receivers.

Signal Detect/Link Fault

Each selected line receiver (i.e., that routed to the clock and data recovery PLL) is simultaneously monitored for

- analog amplitude above limit specified by SDASEL
- transition density greater than specified limit
- range controller reports the received data stream within normal frequency range (± 1500 ppm)^[16]
- receive channel enabled.

All of these conditions must be valid for the signal detect block to indicate a valid signal is present. This status is presented on the LFI (link fault indicator) output.

Analog Amplitude

While most signal monitors are based on fixed constants, the analog amplitude level detection is adjustable to allow operation with highly attenuated signals, or in high-noise environments. This adjustment is made through the SDASEL signal, a 3-level select^[17] (ternary) input, which sets the trip point for the detection of a valid signal at one of three levels, as listed in Table 10.

The analog signal detect monitor is active for the present line receiver, as selected by the INSEL input. When configured for local loop-back (LPEN = HIGH), the analog signal detect monitor is disabled.

Transition Density

The transition detection logic checks for the absence of any transitions spanning greater than six transmission characters (60-bits). If no transitions are present in the data received (within the referenced period), the transition detection logic asserts LFI. The LFI output remains asserted until at least one transition is detected in each of three adjacent received characters.

Table 10. Analog Amplitude Detect Valid Signal Levels^[18]

SDASEL	Typical Signal with Peak Amplitudes Above
LOW	140-mV p-p differential
MID (Open)	280-mV p-p differential
HIGH	420-mV p-p differential

Notes

16. REFCLK has no phase or frequency relationship with the recovered clock(s) and only acts as a centering reference to reduce clock synchronization time. REFCLK must be within ± 1500 PPM ($\pm 0.15\%$) of the remote transmitter's PLL reference (REFCLK) frequency. Although transmitting to a HOTLink II receiver necessitates the frequency difference between the transmitter and receiver reference clocks to be within ± 1500 -PPM, the stability of the crystal needs to be within the limits specified by the appropriate standard when transmitting to a remote receiver that is compliant to that standard. For example, to be IEEE 802.3z Gigabit Ethernet compliant, the frequency stability of the crystal needs to be within ± 100 PPM.
17. When REFCLK is configured for half-rate operation (TXRATE = HIGH), this input is sampled (or the outputs change) relative to both the rising and falling edges of REFCLK.
18. The peak amplitudes listed in this table are for typical waveforms that have generally 3–4 transitions for every ten bits. In a worse case environment the signals may have a sign-wave appearance (highest transition density with repeating 0101...). Signal peak amplitudes levels within this environment type could increase the values in the table above by approximately 100 mV.
19. When a disabled receive channel is reenabled, the status of the LFI output and data on the parallel outputs may be indeterminate for up to 2 ms.

Range Control

The clock/data recovery (CDR) circuit includes logic to monitor the frequency of the phase-locked loop (PLL) voltage controlled oscillator (VCO) used to sample the incoming data stream. This logic ensures that the VCO operates at, or near the rate of the incoming data stream for two primary cases:

- when the incoming data stream resumes after a time in which it has been "missing."
- when the incoming data stream is outside the acceptable frequency range.

To perform this function, the frequency of the VCO is periodically sampled and compared to the frequency of the REFCLK input. If the VCO is running at a frequency beyond ± 1500 ppm^[16] as defined by the reference clock frequency, it is periodically forced to the correct frequency (as defined by REFCLK, SPDSEL, and TXRATE) and then released in an attempt to lock to the input data stream. The sampling and relock period of the range control is calculated as follows: RANGE CONTROL SAMPLING PERIOD = (REFCLKPERIOD) \times (16000).

During the time that the range control forces the PLL VCO to run at REFCLK \times 10 (or REFCLK \times 20 when TXRATE = HIGH) rate, the LFI output will be asserted LOW. While the PLL is attempting to re-lock to the incoming data stream, LFI may be either HIGH or LOW (depending on other factors such as transition density and amplitude detection) and the recovered byte clock (RXCLK) may run at an incorrect rate (depending on the quality or existence of the input serial data stream). After a valid serial data stream is applied, it may take up to one RANGE CONTROL SAMPLING PERIOD before the PLL locks to the input data stream, after which LFI should be HIGH.

Receive Channel Enabled

The CYP(V)15G0101DXB receive channel can be enabled and disabled through the BOE[0] input, as controlled by the RXLE latch-enable signal. When RXLE = HIGH, the signal present on the BOE[0] input is passed through the receive channel enable latch to control the PLL and logic of the receive channel. The BOE[1:0] input functions are listed in Table 8.

When RXLE = HIGH and BOE[0] = HIGH, the receive channel is enabled to receive and recover a serial stream from the line receiver. When RXLE = HIGH and BOE[0] = LOW, the receive channel is disabled and internally configured for minimum power dissipation. When disabled, the channel indicates a constant LFI output. When RXLE returns LOW, the values present on the BOE[1:0] inputs are latched in the Receive Channel Enable Latch, and remain there until RXLE returns HIGH to open the latch again.^[19]

Clock/Data Recovery

The extraction of a bit-rate clock and recovery of bits from a received serial stream is performed by a CDR block within the receive channel. The clock extraction function is performed by a high-performance embedded PLL that tracks the frequency of the transitions in the incoming bit stream and aligns the phase of the internal bit-rate clock to the transitions in the serial data stream.

The CDR accepts a character-rate (bit-rate ÷ 10) or half-character-rate (bit-rate ÷ 20) reference clock from the REFCLK input. This REFCLK input is used to

- ensure that the VCO (within the CDR) is operating at the correct frequency
- reduce PLL acquisition time
- limit unlocked frequency excursions of the CDR VCO when there is no input data present at the selected serial line receiver.

Regardless of the type of signal present, the CDR will attempt to recover a data stream from it. If the frequency of the recovered data stream is outside the limits of the range control monitor, the CDR will switch to track REFCLK instead of the data stream. Once the CDR output (RXCLK) frequency returns back close to REFCLK frequency, the CDR input will be switched back to track the input data stream. In case no data is present at the input, this switching behavior may result in brief RXCLK frequency excursions from REFCLK. However, the validity of the input data stream is indicated by the LFI_{OUT} output. The frequency of REFCLK is required to be within ± 1500 ppm^[20] of the frequency of the clock that drives the REFCLK input of the remote transmitter to ensure a lock to the incoming data stream.

For systems using multiple or redundant connections, the $\overline{\text{LFI}}$ output can be used to select an alternate data stream. When an LFI indication is detected, external logic can toggle selection of the IN1_± and IN2_± inputs through the INSEL input. When a port switch takes place, it is necessary for the receive PLL to reacquire the new serial stream and frame to the incoming character boundaries.

Deserializer/Framer

Each CDR circuit extracts bits from the serial data stream and clocks these bits into the shifter/framer at the bit-clock rate. When enabled, the framer examines the data stream, looking for one or more comma or K28.5 characters at all possible bit positions. The location of these characters in the data stream are used to determine the character boundaries of all following characters.

Framing Character

The CYP(V)15G0101DXB allows selection of two combinations of framing characters to support requirements of different interfaces. The selection of the framing character is made through the FRAMCHAR input.

The specific bit combinations of these framing characters are listed in Table 11. When the specific bit combination of the selected framing character is detected by the framer, the boundaries of the characters present in the received data stream are known.

Table 11. Framing Character Selector

FRAMCHAR	Bits Detected in Framer	
	Character Name	Bits Detected
LOW	Reserved for test	
MID (Open)	Comma+ Comma–	00111110XX ^[21] or 11000001XX
HIGH	–K28.5 +K28.5	0011111010 or 1100000101

Framer

The framer operates in one of three different modes, as selected by the RFMODE input. In addition, the framer itself may be enabled or disabled through the RFEN input. When RFEN = LOW, the framer is disabled, and no combination of bits in a received data stream will alter the character boundaries. When RFEN = HIGH, the framer-mode selected by RFMODE is enabled.

When RFMODE = LOW, the low-latency framer is selected. This framer operates by stretching the recovered character clock until it aligns with the received character boundaries. In this mode, the framer starts its alignment process on the first detection of the selected framing character. To reduce the impact on external circuits that make use of a recovered clock, the clock period is not stretched by more than two bit-periods in any one clock cycle. When operated with a character-rate output clock (RXRATE = LOW), the output of properly framed characters may be delayed by up to nine character-clock cycles from the detection of the selected framing character. When operated with a half-character-rate output clock (RXRATE = HIGH), the output of properly framed characters may be delayed by up to 14 character-clock cycles from the detection of the selected framing character.^[22]

Notes

20. REFCLK has no phase or frequency relationship with the recovered clock(s) and only acts as a centering reference to reduce clock synchronization time. REFCLK must be within ±1500 ppm (±0.15%) of the remote transmitter's PLL reference (REFCLK) frequency. Although transmitting to a HOTLink II receiver necessitates the frequency difference between the transmitter and receiver reference clocks to be within ±1500 ppm, the stability of the crystal needs to be within the limits specified by the appropriate standard when transmitting to a remote receiver that is compliant to that standard. For example, to be IEEE 802.3z Gigabit Ethernet compliant, the frequency stability of the crystal needs to be within ±100 ppm.
21. The standard definition of a Comma contains only seven bits. However, since all valid Comma characters within the 8B/10B character set also have the 8th bit as an inversion of the 7th bit, the compare pattern is extended to a full eight bits to reduce the possibility of a framing error.
22. When receive BIST is enabled on a channel, the low-latency framer must not be enabled. The BIST sequence contains an aliased K28.5 framing character, which would cause the receiver to update its character boundaries incorrectly.

When RFMODE = MID (open), the Cypress-mode multi-byte framer is selected. The required detection of multiple framing characters makes the link much more robust to incorrect framing due to aliased framing characters in the data stream. In this mode, the framer does not adjust the character clock boundary, but instead aligns the character to the already recovered character clock. This ensures that the recovered clock does not contain any significant phase changes or hops during normal operation or framing, and allows the recovered clock to be replicated and distributed to other external circuits or components using PLL-based clock distribution elements. In this framing mode, the character boundaries are only adjusted if the selected framing character is detected at least twice within a span of 50-bits, with both instances on identical 10-bit character boundaries.

When RFMODE = HIGH, the alternate-mode multi-byte framer is enabled. Like the Cypress-mode multi-byte framer, multiple framing characters must be detected before the character boundary is adjusted. In this mode, the framer does not adjust the character clock boundary, but instead aligns the character to the already recovered character clock. In this mode, the data stream must contain a minimum of four of the selected framing characters, received as consecutive characters, on identical 10-bit boundaries, before character framing is adjusted.

Framing is enabled when RFEN = HIGH. If RFEN = LOW, the framer is disabled. When the framer is disabled, no changes are made to the recovered character boundary, regardless of the presence of framing characters in the data stream.

10B/8B Decoder Block

The decoder logic block performs three primary functions:

- decoding the received transmission characters back into data and special character codes
- comparing generated BIST patterns with received characters to permit at-speed link and device testing
- generation of ODD parity on the decoded characters.

10B/8B Decoder

The framed parallel output of the deserializer shifter is passed to the 10B/8B decoder where, if the decoder is enabled (DECMODE ≠ LOW), it is transformed from a 10-bit transmission character back to the original data and special character codes. This block uses the 10B/8B decoder patterns in [Table 20](#) and [Table 21](#) of this data sheet. Valid data characters are indicated by a 000b bit-combination on the RXST[2:0] status bits, and special character codes are indicated by a 001b bit-combination on these same status outputs. Framing characters, invalid patterns, disparity errors, and synchronization status are presented as alternate combinations of these status bits.

The 10B/8B decoder operates in two normal modes, and can also be bypassed. The operating mode for the decoder is controlled by the DECMODE input.

When DECMODE = LOW, the decoder is bypassed and raw 10-bit characters are passed to the output register. In this mode, the receive elasticity buffers are bypassed, and RXCKSEL must be MID.

When DECMODE = MID (or open), the 10-bit transmission characters are decoded using [Table 20](#) and [Table 21](#). Received special code characters are decoded using the Cypress column of [Table 21](#).

When DECMODE = HIGH, the 10-bit transmission characters are decoded using [Table 20](#) and [Table 21](#). Received special code characters are decoded using the alternate column of [Table 21](#).

Receive BIST Operation

The receiver interface contains an internal pattern generator that can be used to validate both device and link operation. This generator is enabled by the BOE[0] signal as listed in [Table 8](#) (when the BISTLE latch enable input is HIGH). When enabled, a register in the receive channel becomes a pattern generator and checker by logically converting to a linear feedback shift register (LFSR). This LFSR generates a 511-character sequence that includes all data and special character codes, including the explicit violation symbols. This provides a predictable yet pseudo-random sequence that can be matched to an identical LFSR in the attached transmitter. If the receive channels are configured for REFCLK clocking (RXCKSEL = LOW), each pass is preceded by a 16-character Word Sync Sequence.

When synchronized with the received data stream, the receiver checks each character in the decoder with each character generated by the LFSR and indicates compare errors and BIST status at the RXST[2:0] bits of the output register.

When the BISTLE signal is HIGH, if the BOE[0] input is LOW the BIST generator/checker in the receive channel is enabled (and if BOE[1] = LOW the BIST generator in the transmit channel is enabled). When BISTLE returns LOW, the values of the BOE[1:0] signals are captured in the BIST enable latch. These values remain in the BIST enable latch until BISTLE is returned high to open the latch again. All captured signals in the BIST enable latch are set HIGH (i.e., BIST is disabled) following a device reset (TRSTZ is sampled LOW).

When BIST is first recognized as being enabled in the receiver, the LFSR is preset to the BIST-loop start-code of D0.0. This D0.0 character is sent only once per BIST loop. The status of the BIST progress and any character mismatches is presented on the RXST[2:0] status outputs.

Code rule violations or running disparity errors that occur as part of the BIST loop do not cause an error indication. RXST[2:0] indicates 010b or 100b for one character period per BIST loop to indicate loop completion. This status can be used to check test pattern progress. These same status values are presented when the decoder is bypassed and BIST is enabled on the receive channel.

The status reported on RXST[2:0] by the BIST state machine are listed in [Table 16](#). When receive BIST is enabled, the same status is reported on the receive status outputs regardless of the state of DECMODE.

The specific patterns checked by each receiver are described in detail in the Cypress application note [HOTLink Built-In Self-test](#). The sequence compared by the CYP(V)15G0101DXB is identical to that in the CY7B933 and CY7C924DX, allowing interoperable systems to be built when used at compatible serial signaling rates.

If the number of invalid characters received ever exceeds the number of valid characters by 16, the receive BIST state machine aborts the compare operations and resets the LFSR to the D0.0 state to look for the start of the BIST sequence again.

When the receive paths are configured for REFCLK clocking (RXCKSEL = LOW), each pass must be preceded by a 16-character Word Sync Sequence to allow output buffer alignment and management of clock frequency variations. This is automatically generated by the transmitter when its local RXCKSEL = LOW.

The BIST state machine requires the characters to be correctly framed for it to detect the BIST sequence. If the low-latency framer is enabled (RFMODE = LOW), the framer will misalign to an aliased framing character within the BIST sequence. If the alternate-mode multi-byte framer is enabled (RFMODE = HIGH) and the receiver outputs are clocked relative to a recovered clock (RXCKSEL = MID), it is necessary to frame the receiver before BIST is enabled. If the receiver outputs are clocked relative to REFCLK (RXCKSEL = LOW), the transmitter precedes every 511 character BIST sequence with a 16-character Word Sync Sequence.

Receive Elasticity Buffer

The receive channel contains an elasticity buffer that is designed to support multiple clocking modes. This buffer allows data to be read using an elasticity buffer read-clock that is asynchronous in both frequency and phase from the elasticity buffer write clock, or to use a read clock that is frequency coherent but with uncontrolled phase relative to the elasticity buffer write clock.

The elasticity buffer is 10 characters deep, and supports a 12-bit-wide data path. It is capable of supporting a decoded character, three status bits, and a parity bit for each character present in the buffer. The write clock for this buffer is always the recovered clock for the read channel.

The read clock for the elasticity buffer can be set to character-rate REFCLK (RXCKSEL = LOW and DECMODE ≠ LOW). The write clock for the elasticity buffer is always recovered clock.

When RXCKSEL = LOW, the receive channel is clocked by REFCLK. The RXCLK± and RXCLKC+ outputs present buffered and delayed forms of REFCLK. In this mode, the receive elasticity buffer is enabled. For REFCLK clocking, the elasticity buffer must be able to insert K28.5 characters and delete framing characters as appropriate. The elasticity buffer is bypassed whenever the decoder is bypassed (DECMODE = LOW). When the decoder and elasticity buffer are bypassed, RXCKSELx must be set to MID. When RXCKSEL = MID (or open), the receive channel output register is clocked by the recovered clock.

The insertion of a K28.5 or deletion of a framing character can occur at any time. However, the actual timing on these insertions and deletions is controlled in part by the how the transmitter sends its data. Insertion of a K28.5 character can only occur when the receiver has a framing character in the elasticity buffer. Likewise, to delete a framing character, one must also be present in the elasticity buffer. To prevent an elasticity buffer overflow or underflow in the receive channel, a minimum density of framing characters must be present in the received data stream.

Prior to reception of valid data, at least one Word Sync Sequence (or at least four framing characters) must be received to allow the receive elasticity buffer to be centered. The elasticity buffer may

also be centered by a device reset operation initiated through the TRSTZ input. However, following such an event, the CYP(V)15G0101DXB will normally require a framing event before it will correctly decode characters.

Receive Modes

The operating mode of the receive path is set through the RXMODE input. The 'Reserved for test' setting (RXMODE = M) is not allowed, even if the receiver is not being used, as it will stop normal function of the device. When the decoder is disabled, the RXMODE setting is ignored as long as it is not a test mode. These modes determine the RXST status reporting. The different receive modes are listed in Table 12.

Table 12. Receive Operating Modes

RX Mode		RXST Status Reporting
Mode Number	RXMODE	
0	L	Status A
1	M	Reserved for test
2	H	Status B

Power Control

The CYP(V)15G0101DXB supports user control of the powered up or down state of the transmit and receive channel. The receive channel is controlled by the RXLE signal and the values present on the BOE[1:0] bus. The transmit channel is controlled by the OELE signal and the values present on the BOE[1:0] bus. If either the transmit or the receive channel is not used, then powering down the unused channel will save power and reduce system heat generation. Controlling system power dissipation will improve the system performance.

Receive Channel

When RXLE = HIGH, the signal on the BOE[0] input directly controls the power enable for the receive PLL and the analog circuit. When BOE[0] = HIGH, the receive channel and its analog circuits are active. When BOE[0] = LOW, the receive channel and its analog circuits are powered down. When RXLE returns LOW, the values present on the BOE[1:0] inputs are latched in the receive channel enable latch. When a disabled receive channel is re-enabled, the status of the LFI output and data on the parallel outputs for the receive channel may be indeterminate for up to 2 ms.

Transmit Channel

When OELE = HIGH, the signals on the BOE[1:0] inputs directly control the power enables for the serial drivers. When a BOE[1:0] input is HIGH, the associated serial driver is enabled. When a BOE[1:0] input is LOW, the associated serial driver is disabled. When both serial drivers are powered down, the logic in the entire transmit channel is also powered down. When OELE returns LOW, the values present on the BOE[1:0] inputs are latched in the output enable latch.

Device Reset State

When the CYP(V)15G0101DXB is reset by assertion of $\overline{\text{TRSTZ}}$, both the transmit enable and receive enable latches are cleared, and the BIST enable latch is preset. In this state, the transmit and receive channels are disabled, and BIST is disabled.

Following a device reset, it is necessary to enable the transmit and receive channels for normal operation. This can be done by sequencing the appropriate values on the BOE[1:0] inputs while the OELE and RXLE signals are raised and lowered. For systems that do not require dynamic control of power, or want the part to power-up in a fixed configuration, it is also possible to strap the RXLE and OELE control signals HIGH to permanently enable their associated latches. Connection of the associated BOE[1:0] signals to a stable HIGH will then enable the transmit and receive channels as soon as the TRSTZ signal is deasserted.

Output Bus

The receive channel presents a 12-signal output bus consisting of

- an eight-bit data bus
- a three-bit status bus
- a parity bit.

The bit assignments of the Data and Status are dependent on the setting of DECMODE. This mapping is shown in Table 13.

Table 13. Output Register Bit Assignments^[23]

Signal Name	DECMODE = LOW	DECMODE = MID or HIGH
RXST[2] (LSB)	COMDET	RXST[2]
RXST[1]	DOUT[0]	RXST[1]
RXST[0]	DOUT[1]	RXST[0]
RXD[0]	DOUT[2]	RXD[0]
RXD[1]	DOUT[3]	RXD[1]
RXD[2]	DOUT[4]	RXD[2]
RXD[3]	DOUT[5]	RXD[3]
RXD[4]	DOUT[6]	RXD[4]
RXD[5]	DOUT[7]	RXD[5]
RXD[6]	DOUT[8]	RXD[6]
RXD[7] (MSB)	DOUT[9]	RXD[7]

When the 10B/8B decoder is bypassed (DECMODE = LOW), the framed 10-bit character is presented to the receiver output register, along with a status output (COMDET) indicating if the

character in the output register is one of the selected framing characters. The bit usage and mapping of the external signals to the raw 10B transmission character is shown in Table 14.

Table 14. Decoder Bypass Mode (DECMODE = LOW)

Signal Name	Bus Weight	10B Name
RXST[2] (LSB)	COMDET	
RXST[1]	2 ⁰	a
RXST[0]	2 ¹	b
RXD[0]	2 ²	c
RXD[1]	2 ³	d
RXD[2]	2 ⁴	e
RXD[3]	2 ⁵	i
RXD[4]	2 ⁶	f
RXD[5]	2 ⁷	g
RXD[6]	2 ⁸	h
RXD[7] (MSB)	2 ⁹	j

The COMDET output is HIGH when the character in the output register contains the selected framing character at the proper character boundary, and LOW for all other bit combinations.

When the low-latency framer and half-rate receive port clocking is also enabled (RFMODE = LOW, RXRATE = HIGH, and RXCKSEL = MID), the framer will stretch the recovered clock to the nearest 20-bit boundary such that the rising edge of RXCLK+ occurs when COMDET = HIGH in the output register.

When the Cypress or alternate-mode framer is enabled and half-rate receive port clocking is also enabled (RFMODE ≠ LOW and RXRATE = HIGH), the output clock is not modified when framing is detected, but a single pipeline stage may be added or subtracted from the data stream by the framer logic such that the rising edge of RXCLK+ occurs when COMDET = HIGH in the output register. This adjustment only occurs when the framer is enabled (RFEN = HIGH). When the framer is disabled, the clock boundaries are not adjusted, and COMDET may be asserted during the rising edge of RXCLK- (if an odd number of characters were received following the initial framing).

Note

23. The RXOP output is also driven from the Output Register, but its interpretation is under the separate control of PARCTL.

Parity Generation

In addition to the eleven data and status bits that are presented, an RXOP parity output is also available. This allows the CYP(V)15G0101DXB to support ODD parity generation. To handle a wide range of system environments, the CYP(V)15G0101DXB supports different forms of parity generation (in addition to no parity). When the decoder is enabled (DECMODE \neq LOW), parity can be generated on

- the RXD[7:0] character
- the RXD[7:0] character and RXST[2:0] status.

When the decoder is bypassed (DECMODE = LOW), parity can be generated on

- the RXD[7:0] and RXST[1:0] bits
- the RXD[7:0] and RXST[2:0] bits.

These modes differ in the number of bits which are included in the parity calculation. For all cases, only ODD parity is provided which ensures that at least one bit of the data bus is always a logic-1. Those bits covered by parity generation are listed in [Table 15](#).

Parity generation is enabled through the 3-level select PARCTL input. When PARCTL = LOW, parity checking is disabled, and the RXOP output is disabled (high Z).

Table 15. Output Register Parity Generation

Signal Name	Receive Parity Generate Mode (PARCTL)			
	LOW ^[24]	MID		HIGH
		DECMODE = LOW	DECMODE \neq LOW	
RXST[2]				X ^[25]
RXST[1]		X		X
RXST[0]		X		X
RXD[0]		X	X	X
RXD[1]		X	X	X
RXD[2]		X	X	X
RXD[3]		X	X	X
RXD[4]		X	X	X
RXD[5]		X	X	X
RXD[6]		X	X	X
RXD[7]		X	X	X

When PARCTL = MID (open) and the decoder is enabled (DECMODE \neq LOW), ODD parity is generated for the received and decoded character in the RXD[7:0] signals and is presented on the RXOP output.

When PARCTL = MID (open) and the decoder is bypassed (DECMODE = LOW), ODD parity is generated for the received and decoded character in the RXD[7:0] and RXST[1:0] bit positions.

When PARCTL = HIGH, ODD parity is generated for the TXD[7:0] and the RXST[2:0] status bits.

Receive Status Bits

When the 10B/8B decoder is enabled (DECMODE \neq LOW), each character presented at the output register includes three associated status bits. These bits are used to identify

- if the contents of the data bus are valid
- the type of character present
- the state of receive BIST operations (regardless of the state of DECMODE)
- character violations.

These conditions normally overlap; for example, a valid data character received with incorrect running disparity is not reported as a valid data character. It is instead reported as a decoder violation of some specific type. This implies a hierarchy or priority level to the various status bit combinations. The hierarchy and value of each status is listed in [Table 16](#).

Within these status decodes, there are three forms of status reporting. The two normal or data status reporting modes (Type A and Type B) are selectable through the RXMODE input. These status types allow compatibility with legacy systems, while allowing full reporting in new systems. The third status type is used for reporting receive BIST status and progress.

BIST Status State Machine

When the receive path is enabled to look for and compare the received data stream with the BIST pattern, the RXST[2:0] bits identify the present state of the BIST compare operation.

The BIST state machine has multiple states, as shown in [Figure 2 on page 24](#) and [Table 16](#). When the receive PLL detects an out-of-lock condition, the BIST state is forced to the Start-of-BIST state, regardless of the present state of the BIST state machine. If the number of detected errors ever exceeds the number of valid matches by greater than 16, the state machine is forced to the WAIT_FOR_BIST state where it monitors the interface for the first character (D0.0) of the next BIST sequence. Also, if the elasticity buffer ever hits and overflow/underflow condition, the status is forced to the BIST_START until the buffer is re-centered (approximately nine character periods).

To ensure compatibility between the source and destination systems when operating in BIST, the sending and receiving ends of the BIST sequence must use the same clock setup (RXCKSEL = MID or RXCKSEL = LOW).

Notes

24. Receive path parity output driver (RXOP) is disabled (high Z) when PARCTL = LOW.

25. When the decoder is bypassed (DECMODE = LOW) and BIST is not enabled (Receive BIST latch output is HIGH), RXST[2] is driven to a logic-0, except when the character in the output buffer is a framing character.

JTAG Support

The CYP(V)15G0101DXB contains a JTAG port to allow system level diagnosis of device interconnect. Of the available JTAG modes, only boundary scan is supported. This capability is present only on the LVTTTL inputs, LVTTTL outputs and the REFCLK± clock input. The high-speed serial inputs and outputs are not part of the JTAG test chain.

JTAG ID

The JTAG device ID for the CYP(V)15G0101DXB is "1C804069"x.

3-Level Select Inputs

Each 3-level select input reports as two bits in the scan register. These bits report the LOW, MID, and HIGH state of the associated input as 00, 10, and 11, respectively.

Table 16. Receive Character Status Bits

RXST[2:0]	Priority	Description		
		Type-A Status	Type-B Status	Receive BIST Status (Receive BIST = Enabled)
000	7	Normal character received. The valid data character on the output bus meets all the formatting requirements of data characters listed in Table 20 .		BIST data compare. Character compared correctly
001	7	Special code detected. The valid special character on the output bus meets all the formatting requirements of the special code characters listed in Table 21 , but is not the presently selected framing character or a decoder violation indication.		BIST command compare. Character compared correctly
010	2	Receive elasticity buffer Underrun/Overrun error. The receive buffer was not able to add/drop a K28.5 or framing character.	RESERVED	BIST last good. Last character of BIST sequence detected and valid.
011	5	Framing character detected. This indicates that a character matching the patterns identified as a framing character (as selected by FRAMCHAR) was detected. The decoded value of this character is present on the output bus.		RESERVED
100	4	Codeword violation. The character on the output bus is a C0.7. This indicates that the received character cannot be decoded into any valid character.		BIST last bad. Last character of BIST sequence detected invalid.
101	1	PLL out of lock. This indicates a PLL out of lock condition.		BIST start. Receive BIST is enabled on this channel, but character compares have not yet commenced. This also indicates a PLL out of lock condition, and elasticity buffer overflow/underflow conditions.
110	6	Running disparity error. The character on the output bus is a C4.7, C1.7, or C2.7.		BIST error. While comparing characters, a mismatch was found in one or more of the decoded character bits.
111	3	RESERVED		BIST wait. The receiver is comparing characters. but has not yet found the start of BIST character to enable the LFSR.

Figure 2. Receive BIST State Machine

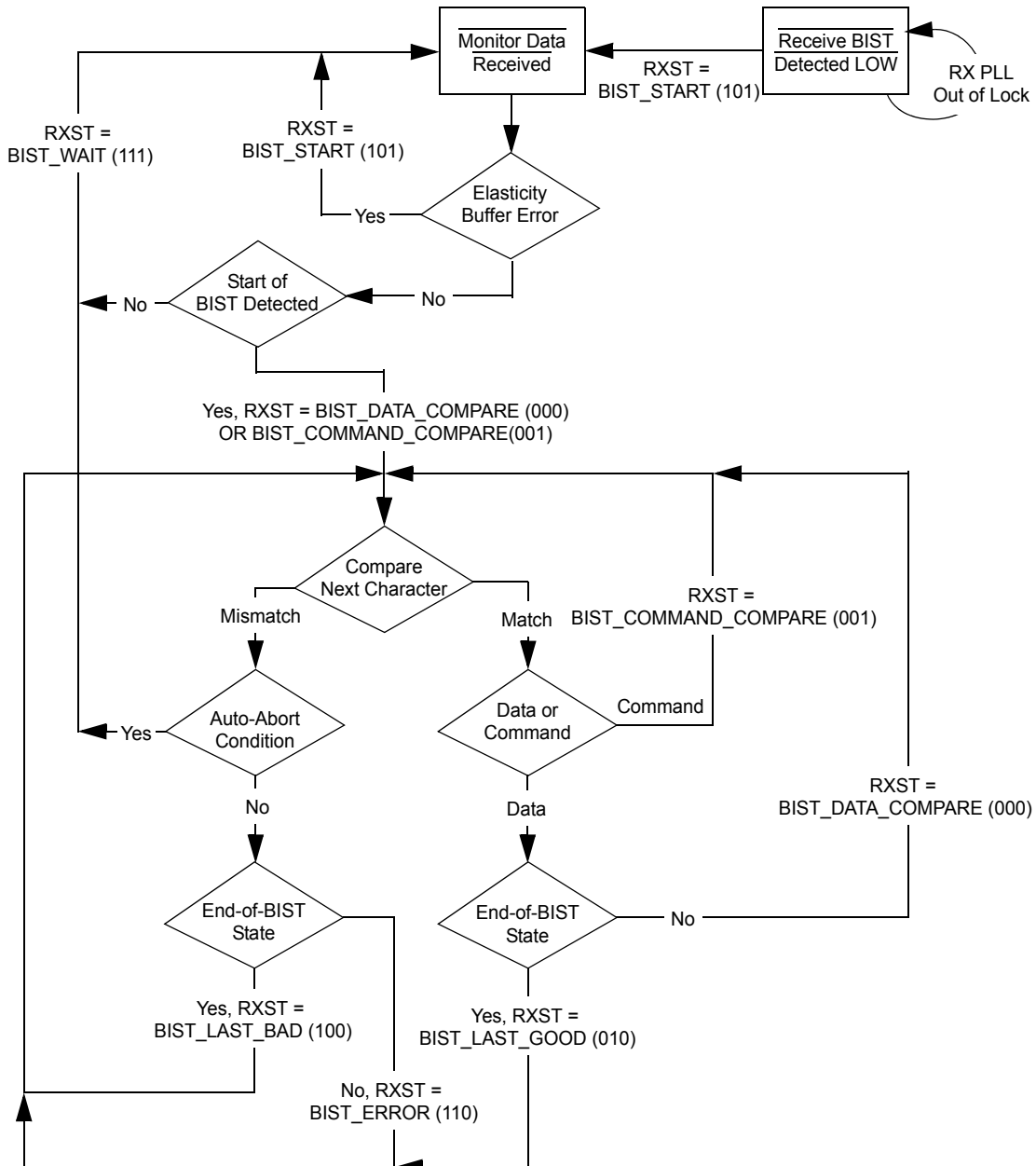

Maximum Ratings

Exceeding maximum ratings may shorten the useful life of the device. User guidelines are not tested.

Storage temperature	-65 °C to +150 °C
Ambient temperature with power applied	-55 °C to +125 °C
Supply voltage to ground potential	-0.5 V to +3.8 V
DC voltage applied to LVTTTL outputs in high Z State.....	-0.5 V to $V_{CC} + 0.5 V$
Output current into LVTTTL outputs (LOW).....	60 mA
DC input voltage	-0.5 V to $V_{CC} + 0.5 V$

Static discharge voltage..... > 2000 V
(per MIL-STD-883, method 3015)

Latch-up current

Power-up Requirements

The CYP(V)15G0101DXB requires one power-supply. The voltage on any input or I/O pin cannot exceed the power pin during power-up.

Operating Range

Range	Ambient Temperature	V_{CC}
Commercial	0 °C to +70 °C	+3.3 V ± 5%
Industrial	-40 °C to +85 °C	+3.3 V ± 5%

DC Electrical Characteristics

Over the Operating Range

Parameter	Description	Test Conditions	Min	Max	Unit
LVTTTL-compatible Outputs					
V_{OHT}	Output HIGH voltage	$I_{OH} = -4 \text{ mA}, V_{CC} = \text{Min}$	2.4	V_{CC}	V
V_{OLT}	Output LOW voltage	$I_{OL} = 4 \text{ mA}, V_{CC} = \text{Min}$	0	0.4	V
I_{OST}	Output short circuit current	$V_{OUT} = 0V^{[26]}$	-20	-100	mA
I_{OZL}	High Z output leakage current		-20	20	µA
LVTTTL-compatible Inputs					
V_{IHT}	Input HIGH voltage		2.0	$V_{CC} + 0.3$	V
V_{ILT}	Input LOW voltage		-0.5	0.8	V
I_{IHT}	Input HIGH current	REFCLK Input, $V_{IN} = V_{CC}$	-	1.5	mA
		Other Inputs, $V_{IN} = V_{CC}$	-	+40	µA
I_{ILT}	Input LOW current	REFCLK Input, $V_{IN} = 0.0 V$	-	-1.5	mA
		Other Inputs, $V_{IN} = 0.0 V$	-	-40	µA
I_{IHPDT}	Input HIGH current with internal pull-down	$V_{IN} = V_{CC}$	-	+200	µA
I_{ILPUT}	Input LOW current with internal pull-up	$V_{IN} = 0.0 V$	-	-200	µA
LVDIFF Inputs: REFCLK±					
$V_{DIFF}^{[27]}$	Input differential voltage		400	V_{CC}	mV
V_{IHHP}	Highest input HIGH voltage		1.2	V_{CC}	V
V_{ILLP}	Lowest input LOW voltage		0.0	$V_{CC} / 2$	V
$V_{COMREF}^{[28]}$	Common mode range		1.0	$V_{CC} - 1.2$	V
3-Level Inputs					
V_{IHH}	3-level input HIGH voltage	$\text{Min} \leq V_{CC} \leq \text{Max}$	$0.87 \times V_{CC}$	V_{CC}	V
V_{IMM}	3-level input MID voltage	$\text{Min} \leq V_{CC} \leq \text{Max}$	$0.47 \times V_{CC}$	$0.53 \times V_{CC}$	V
V_{ILL}	3-level input LOW voltage	$\text{Min} \leq V_{CC} \leq \text{Max}$	0.0	$0.13 \times V_{CC}$	V
I_{IHH}	Input HIGH current	$V_{IN} = V_{CC}$	-	200	µA
I_{IMM}	Input MID current	$V_{IN} = V_{CC}/2$	-50	50	µA
I_{ILL}	Input LOW current	$V_{IN} = \text{GND}$	-	-200	µA
Differential CML Serial Outputs: OUT1±, OUT2±					
V_{OHC}	Output HIGH voltage (V_{CC} referenced)	100 Ω differential load	$V_{CC} - 0.5$	$V_{CC} - 0.2$	V
		150 Ω differential load	$V_{CC} - 0.5$	$V_{CC} - 0.2$	V

Notes

26. Tested one output at a time, output shorted for less than one second, less than 10% duty cycle.

27. This is the minimum difference in voltage between the true and complement inputs required to ensure detection of a logic-1 or logic-0. A logic-1 exists when the true (+) input is more positive than the complement (-) input. A logic-0 exists when the complement (-) input is more positive than true (+) input.

28. The common mode range defines the allowable range of REFCLK+ and REFCLK- when REFCLK+ = REFCLK-. This marks the zero-crossing between the true and complement inputs as the signal switches between a logic-1 and a logic-0.

DC Electrical Characteristics

Over the Operating Range (continued)

Parameter	Description	Test Conditions	Min	Max	Unit
V _{OLC}	Output LOW voltage (V _{CC} referenced)	100 Ω differential load	V _{CC} - 1.4	V _{CC} - 0.7	V
		150 Ω differential load	V _{CC} - 1.4	V _{CC} - 0.7	V
V _{ODIF}	Output differential voltage (OUT+) - (OUT-)	100 Ω differential load	450	900	mV
		150 Ω differential load	560	1000	mV
Differential Serial Line Receiver Inputs: IN1±, IN2±					
V _{DIFFS} [29]	Input differential voltage (IN+) - (IN-)		100	1200	mV
V _{IHE}	Highest input HIGH voltage		-	V _{CC}	V
V _{ILE}	Lowest input LOW voltage		V _{CC} - 2.0	-	V
I _{IHE}	Input HIGH current	V _{IN} = V _{IHE} Max	-	1350	μA
I _{ILE}	Input LOW current	V _{IN} = V _{ILE} Min	-700	-	μA
V _{COM} [30, 31]	Common mode input range		V _{CC} - 1.95	V _{CC} - 0.05	V

Power Supply			Typ [33]	Max [32]	Unit
I _{CC}	Power supply current REFCLK= Max	Commercial	390	500	mA
		Industrial		510	mA
I _{CC}	Power supply current REFCLK = 125 MHz	Commercial	390	500	mA
		Industrial		510	mA

AC Test Loads and Waveforms

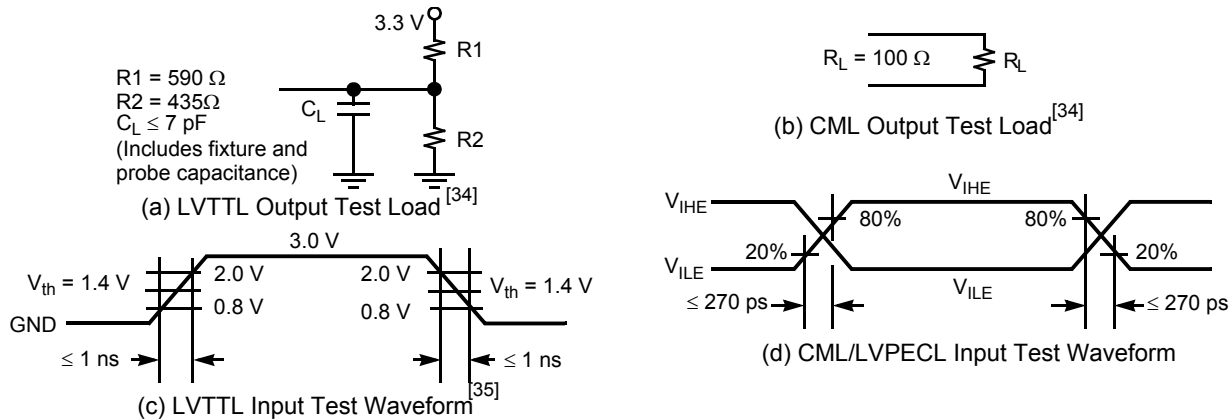

Notes

29. This is the minimum difference in voltage between the true and complement inputs required to ensure detection of a logic-1 or logic-0. A logic-1 exists when the true (+) input is more positive than the complement (-) input. A logic-0 exists when the complement (-) input is more positive than true (+) input.
30. The common mode range defines the allowable range of INPUT+ and INPUT- when INPUT+ = INPUT-. This marks the zero-crossing between the true and complement inputs as the signal switches between a logic-1 and a logic-0.
31. Not applicable for AC-coupled interfaces. For AC-coupled interfaces, V_{DIFFS} requirement still needs to be satisfied.
32. Maximum I_{CC} is measured with V_{CC} = MAX, with all Serial Drivers enabled, parallel outputs unloaded, sending a alternating 01 pattern to the Serial Input Receiver.
33. Typical I_{CC} is measured under similar conditions except with V_{CC} = 3.3V, T_A = 25°C, parallel outputs unloaded, RXCKSEL = MID, and with one Serial Line Driver sending a continuous alternating 01 pattern to the Serial Input Receiver.
34. Cypress uses constant current (ATE) load configurations and forcing functions. This figure is for reference only. 5pF differential load reflects tester capacitance, and is recommended at low data rates only.
35. The LVTTTL switching threshold is 1.4V. All timing references are made relative to the point where the signal edges crosses this threshold voltage.

CYP(V)15G0101DXB AC Characteristics

Over the Operating Range

Parameter	Description	Min	Max	Unit
Transmitter LVTTTL Switching Characteristics				
f_{TS}	TXCLK clock frequency	19.5	150	MHz
t_{TXCLK}	TXCLK period	6.66	51.28	ns
$t_{TXCLKH}^{[36]}$	TXCLK HIGH time	2.2	–	ns
$t_{TXCLKL}^{[36]}$	TXCLK LOW time	2.2	–	ns
$t_{TXCLKR}^{[36, 37, 38]}$	TXCLK rise time	0.2	1.7	ns
$t_{TXCLKF}^{[36, 37, 38]}$	TXCLK fall time	0.2	1.7	ns
t_{TXDS}	Transmit data det-up time to TXCLK \uparrow (TXCKSEL \neq LOW)	1.7	–	ns
t_{TXDH}	Transmit data hold time from TXCLK \uparrow (TXCKSEL \neq LOW)	0.8	–	ns
f_{TOS}	TXCLKO clock frequency = 1x or 2x REFCLK frequency	19.5	150	MHz
t_{TXCLKO}	TXCLKO period	6.66	51.28	ns
$t_{TXCLKOD+}$	TXCLKO+ duty cycle with 60% HIGH time	–1.0	+0.5	ns
$t_{TXCLKOD-}$	TXCLKO– duty cycle with 40% HIGH time	–0.5	+1.0	ns
Receiver LVTTTL Switching Characteristics				
f_{RS}	RXCLK clock output frequency	9.75	150	MHz
t_{RXCLKP}	RXCLK period	6.66	102.56	ns
t_{RXCLKH}	RXCLK HIGH time (RXRATE = LOW)	2.33 ^[36]	26.64	ns
	RXCLK HIGH time (RXRATE = HIGH)	5.66	52.28	ns
t_{RXCLKL}	RXCLK LOW time (RXRATE = LOW)	2.33 ^[36]	26.64	ns
	RXCLK LOW time (RXRATE = HIGH)	5.66	52.28	ns
t_{RXCLKD}	RXCLK duty cycle centered at 50%	–1.0	+1.0	ns
$t_{RXCLKR}^{[36]}$	RXCLK rise time	0.3	1.2	ns
$t_{RXCLKF}^{[36]}$	RXCLK fall time	0.3	1.2	ns
$t_{RXDV-}^{[39]}$	Status and data valid time to RXCLK (RXCKSEL = MID)	5UI – 1.5	–	ns
	Status and data valid time to RXCLK (HALF RATE RECOVERED CLOCK)	5UI – 1.0	–	ns
$t_{RXDV+}^{[39]}$	Status and data valid time from RXCLK (RXCKSEL = MID)	5UI – 1.8	–	ns
	Status and data valid time from RXCLK (HALF RATE RECOVERED CLOCK)	5UI – 2.3	–	ns
REFCLK Switching Characteristics Over the Operating Range				
f_{REF}	REFCLK clock frequency	19.5	150	MHz
t_{REFCLK}	REFCLK period	6.6	51.28	ns
t_{REFH}	REFCLK HIGH time (TXRATE = HIGH)	5.9	–	ns
	REFCLK HIGH time (TXRATE = LOW)	2.9 ^[36]	–	ns
t_{REFL}	REFCLK LOW time (TXRATE = HIGH)	5.9	–	ns
	REFCLK LOW time (TXRATE = LOW)	2.9 ^[36]	–	ns
$t_{REFD}^{[40]}$	REFCLK duty cycle	30	70	%
$t_{REFR}^{[36, 37, 38]}$	REFCLK rise time (20% – 80%)	–	2	ns
$t_{REFF}^{[36, 37, 38]}$	REFCLK fall time (20% – 80%)	–	2	ns
t_{TREFDS}	Transmit data setup time to REFCLK (TXCKSEL = LOW)	1.7	–	ns
t_{TREFDH}	Transmit data hold time from REFCLK (TXCKSEL = LOW)	0.8	–	ns

Notes

36. Tested initially and after any design or process changes that may affect these parameters, but not 100% tested.

37. The ratio of rise time to falling time must not vary by greater than 2:1.

38. For a given operating frequency, neither rise or fall specification can be greater than 20% of the clock-cycle period or the data sheet maximum time.

39. Parallel data output specifications are only valid if all inputs or outputs are loaded with similar DC and AC loads.

40. The duty cycle specification is a simultaneous condition with the t_{REFH} and t_{REFL} parameters. This means that at faster character rates the REFCLK duty cycle cannot be as large as 30%–70%.

CYP(V)15G0101DXB AC Characteristics (continued)

Over the Operating Range

Parameter	Description	Min	Max	Unit	
$t_{RREFDA}^{[43]}$	Receive data access time from REFCLK (RXCKSEL = LOW)	–	9.5	ns	
t_{RREFDV}	Receive data valid time from REFCLK (RXCKSEL = LOW)	2.5	–	ns	
t_{REFDV-}	Received data valid time to RXCLK (RXCKSEL = LOW)	10UI – 4.7	–	ns	
t_{REFDV+}	Received data valid time from RXCLK (RXCKSEL = LOW)	0.5	–	ns	
$t_{REFCDV-}$	Received data valid time to RXCLKC (RXCKSEL = LOW)	10UI – 4.3	–	ns	
$t_{REFCDV+}$	Received data valid time from RXCLKC (RXCKSEL = LOW)	–0.2	–	ns	
$t_{REFRX}^{[41, 42]}$	REFCLK frequency referenced to extracted received clock frequency	–1500	+1500	ppm	
Transmit Serial Outputs and TX PLL Characteristics					
t_B	Bit time		5100	666	ps
$t_{RISE}^{[42]}$	CML output rise time 20%–80% (CML test load)	SPDSEL = HIGH	60	270	ps
		SPDSEL = MID	100	500	ps
		SPDSEL = LOW	180	1000	ps
$t_{FALL}^{[42]}$	CML output fall time 80%–20% (CML test load)	SPDSEL = HIGH	60	270	ps
		SPDSEL = MID	100	500	ps
		SPDSEL = LOW	180	1000	ps
$t_{DJ}^{[42, 44, 46]}$	Deterministic Jitter (peak-peak)	IEEE 802.3z ^[47]	–	25	ps
$t_{RJ}^{[42, 45, 46]}$	Random Jitter (σ)	IEEE 802.3z ^[47]	–	11	ps
t_{TXLOCK}	Transmit PLL lock to REFCLK		–	200	us
Receive Serial Inputs and CDR PLL Characteristics					
t_{RXLOCK}	Receive PLL lock to input data stream (cold start)		–	376K	UI ^[48]
	Receive PLL lock to input data stream		–	376K	UI
$t_{RXUNLOCK}$	Receive PLL unlock rate		–	46	UI
$t_{JTOL}^{[46]}$	Total jitter tolerance	IEEE 802.3z ^[47]	600	–	ps
$t_{DJTOL}^{[46]}$	Deterministic jitter tolerance	IEEE 802.3z ^[47]	370	–	ps
Capacitance^[42]					
Parameter	Description	Test Conditions	Max	Unit	
C_{INTTL}	TTL input capacitance	$T_A = 25\text{ }^\circ\text{C}$, $f_0 = 1\text{ MHz}$, $V_{CC} = 3.3\text{ V}$	7	pF	
C_{INPECL}	PECL input capacitance	$T_A = 25\text{ }^\circ\text{C}$, $f_0 = 1\text{ MHz}$, $V_{CC} = 3.3\text{ V}$	4	pF	

Notes

41. REFCLK has no phase or frequency relationship with the recovered clock(s) and only acts as a centering reference to reduce clock synchronization time. REFCLK must be within ± 1500 ppm ($\pm 0.15\%$) of the remote transmitter's PLL reference (REFCLK) frequency. Although transmitting to a HOTLink II receiver necessitates the frequency difference between the transmitter and receiver reference clocks to be within ± 1500 ppm, the stability of the crystal needs to be within the limits specified by the appropriate standard when transmitting to a remote receiver that is compliant to that standard. For example, to be IEEE 802.3z Gigabit Ethernet compliant, the frequency stability of the crystal needs to be within ± 100 ppm.
42. Tested initially and after any design or process changes that may affect these parameters, but not 100% tested.
43. Since this timing parameter is greater than the minimum time period of REFCLK it sets an upper limit to the frequency in which REFCLKx can be used to clock the receive data out of the output register. For predictable timing, users can use this parameter only if REFCLK period is greater than sum of t_{RREFDA} and set-up time of the upstream device. When this condition is not true, RXCLKC \pm or RXCLKA \pm (a buffered or delayed version of REFCLK when RXCKSELx = LOW) could be used to clock the receive data out of the device.
44. While sending continuous K28.5s, outputs loaded to a balanced 100 Ω load, measured at the cross point of the differential outputs over the operating range.
45. While sending continuous K28.7s, after 100,000 samples measured at the cross point of differential outputs, time referenced to REFCLK input, over the operating range.
46. Total jitter is calculated at an assumed BER of $1E - 12$. Hence: Total Jitter (t_j) = ($t_{RJ} * 14$) + t_{DJ} .
47. Also meets all Jitter Generation and Jitter Tolerance requirements as specified by SMPTE 259M, SMPTE 292M, CPRI, ESCON, FICON, Fibre Channel and DVB-ASI.
48. Receiver UI (Unit Interval) is calculated as $1/(f_{REF} * 20)$ (when RXRATE = HIGH) or $1/(f_{REF} * 10)$ (when RXRATE = LOW) if no data is being received, or $1/(f_{REF} * 20)$ (when RXRATE = HIGH) or $1/(f_{REF} * 10)$ (when RXRATE = LOW) of the remote transmitter if data is being received. In an operating link this is equivalent to t_B .

Switching Waveforms for the HOTLink II Transmitter

Transmit Interface Write Timing TXCKSEL ≠ LOW

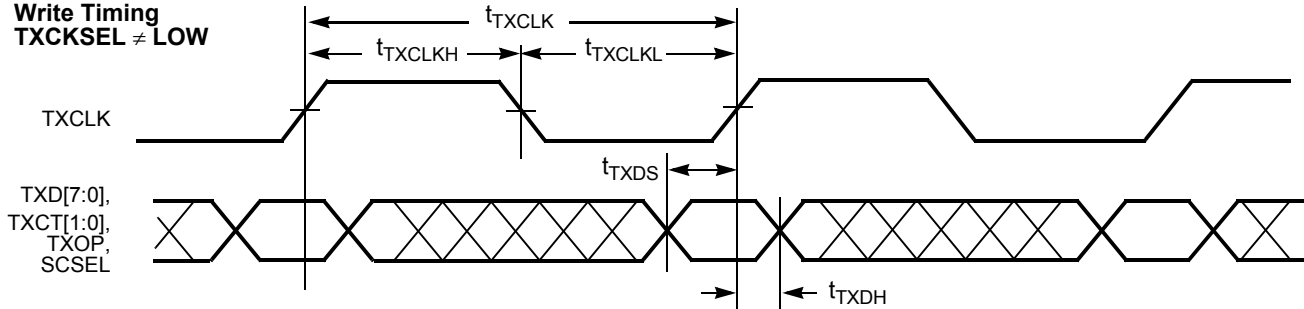

Transmit Interface Write Timing TXCKSEL = LOW TXRATE = LOW

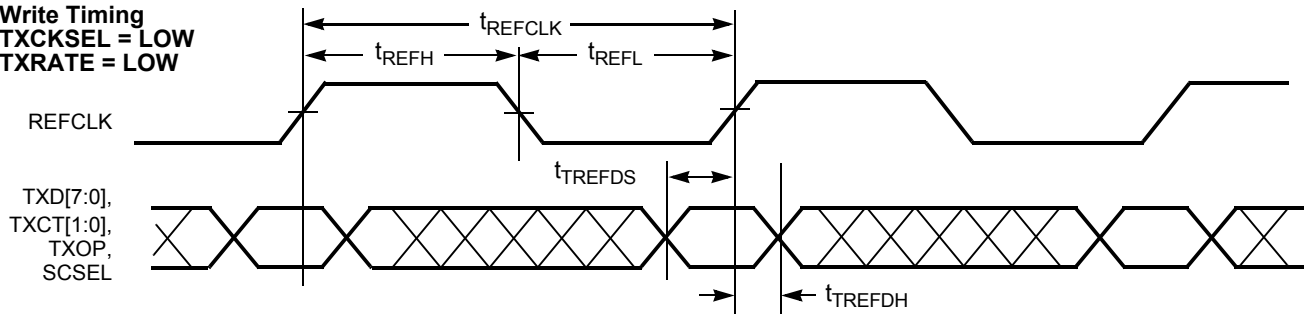

Transmit Interface Write Timing TXCKSEL = LOW TXRATE = HIGH

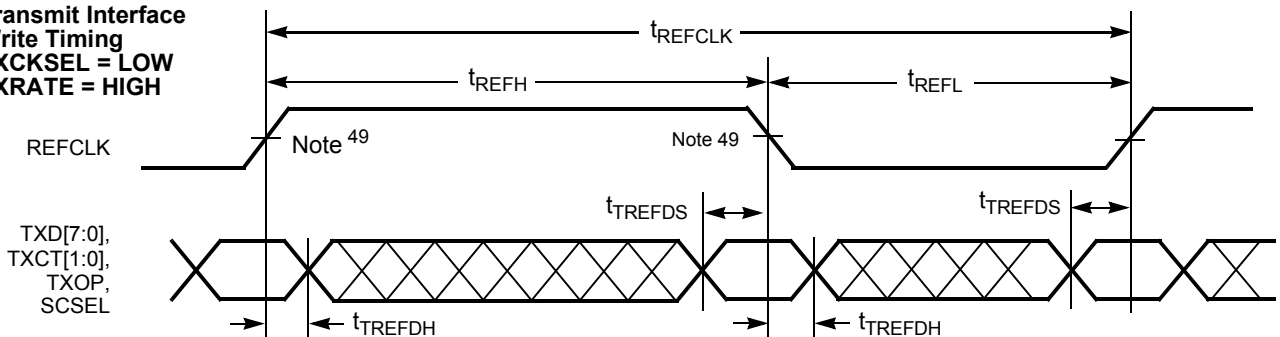

Transmit Interface TXCLKO Timing TXCKSEL = LOW TXRATE = HIGH

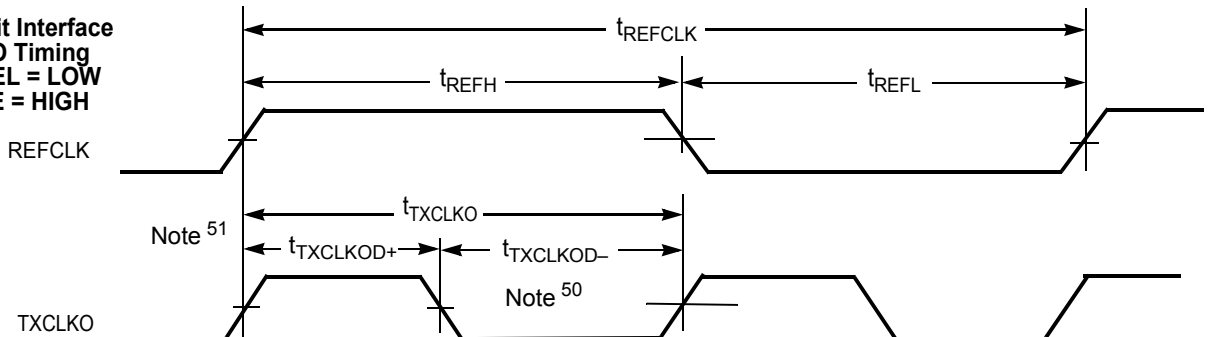

Notes

49. When REFCLK is configured for half-rate operation (TXRATE = HIGH) and data is captured using REFCLK instead of TXCLK clock (TXCKSEL = LOW), data is captured using both the rising and falling edges of REFCLK.
50. The TXCLKO output is at twice the rate of REFCLK when TXRATE = HIGH and same rate as REFCLK when TXRATE = LOW. TXCLKO does not follow the duty cycle of REFCLK.
51. The rising edge of TXCLKO output has no direct phase relationship to the REFCLK input.

**Transmit Interface
TXCLKO Timing
TXCKSEL = LOW
TXRATE = LOW**

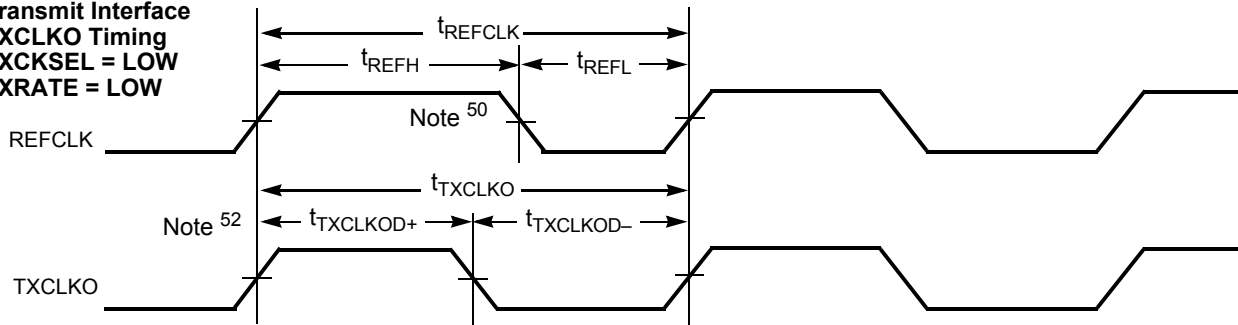

**Receive Interface
Read Timing
RXCKSEL = LOW
TXRATE = LOW**

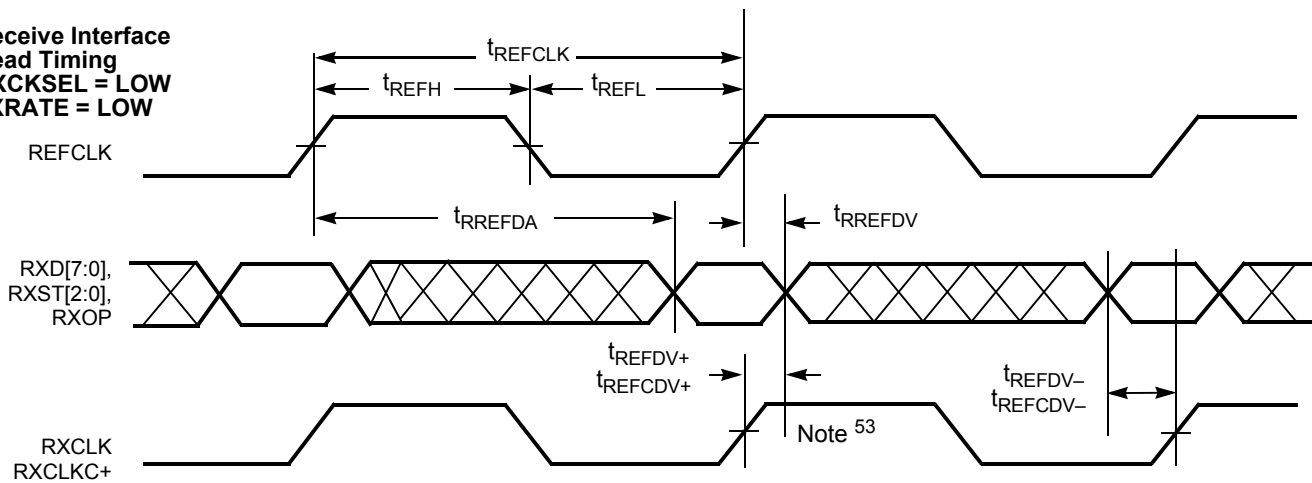

**Receive Interface
Read Timing
RXCKSEL = LOW
TXRATE = HIGH**

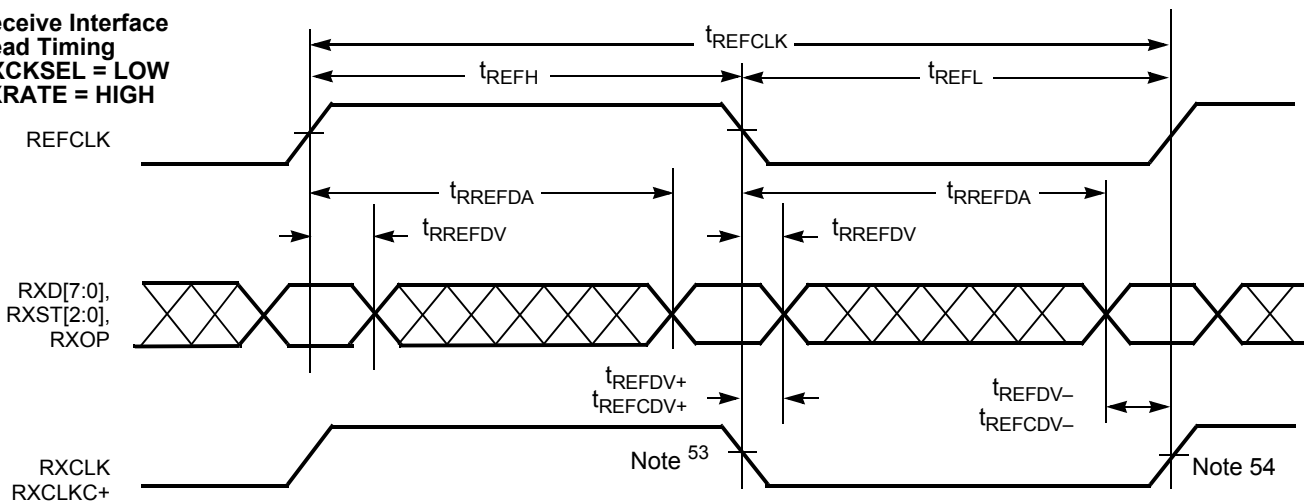

Notes

- 52. The rising edge of TXCLKO output has no direct phase relationship to the REFCLK input.
- 53. RXCLK and RXCLK+ are delayed versions of REFCLK when RXCKSEL = LOW, and are different in phase from each other.
- 54. When operated with a half-rate REFCLK, the setup and hold specifications for data relative to RXCLK are relative to both rising and falling edges of the clock output

**Receive Interface
 Read Timing
 RXCKSEL = MID
 RXRATE = LOW**

**Receive Interface
 Read Timing
 RXCKSEL = MID
 RXRATE = HIGH**

Table 17. Package Coordinate Signal Allocation

Ball ID	Signal Name	Signal Type	Ball ID	Signal Name	Signal Type	Ball ID	Signal Name	Signal Type
A1	VCC	POWER	D5	GND	GROUND	G9	TXCLKO+	LVTTTL OUT
A2	IN2+	CML IN	D6	GND	GROUND	G10	TXCLKO-	LVTTTL OUT
A3	VCC	POWER	D7	GND	GROUND	H1	RXD[0]	LVTTTL OUT
A4	OUT2-	CML OUT	D8	TMS	LVTTTL IN PU	H2	RXD[2]	LVTTTL OUT
A5	RXMODE	3-LEVEL SEL	D9	TRSTZ	LVTTTL IN PU	H3	RXD[6]	LVTTTL OUT
A6	TXMODE[1]	3-LEVEL SEL	D10	TDI	LVTTTL IN PU	H4	LF1	LVTTTL OUT
A7	IN1+	CML IN	E1	BISTLE	LVTTTL IN PU	H5	TXCT[1]	LVTTTL IN
A8	VCC	POWER	E2	DECMODE	3-LEVEL SEL	H6	TXD[6]	LVTTTL IN
A9	OUT1-	CML OUT	E3	OELE	LVTTTL IN PU	H7	TXD[3]	LVTTTL IN
A10	VCC	POWER	E4	GND	GROUND	H8	TXCLK	LVTTTL IN PD
B1	VCC	POWER	E5	GND	GROUND	H9	TXRST	LVTTTL IN PU
B2	IN2-	CML IN	E6	GND	GROUND	H10	#NC	NO CONNECT
B3	TDO	LVTTTL 3-S OUT	E7	GND	GROUND	J1	VCC	POWER
B4	OUT2+	CML OUT	E8	TCLK	LVTTTL IN PD	J2	RXD[3]	LVTTTL OUT
B5	TXRATE	LVTTTL IN PD	E9	RXCKSEL	3-LEVEL SEL	J3	RXD[7]	LVTTTL OUT
B6	TXMODE[0]	3-LEVEL SEL	E10	TXCKSEL	3-LEVEL SEL	J4	RXCLK-	LVTTTL OUT
B7	IN1-	CML IN	F1	RXST[2]	LVTTTL OUT	J5	TXCT[0]	LVTTTL IN
B8	#NC	NO CONNECT	F2	RXST[1]	LVTTTL OUT	J6	TXD[5]	LVTTTL IN
B9	OUT1+	CML OUT	F3	RXST[0]	LVTTTL OUT	J7	TXD[2]	LVTTTL IN
B10	VCC	POWER	F4	GND	GROUND	J8	TXD[0]	LVTTTL IN
C1	RFEN	LVTTTL IN PD	F5	GND	GROUND	J9	#NC	NO CONNECT
C2	LPEN	LVTTTL IN PD	F6	GND	GROUND	J10	VCC	POWER
C3	RXLE	LVTTTL IN PU	F7	GND	GROUND	K1	VCC	POWER
C4	RXCLKC+	LVTTTL 3-S OUT	F8	TXPER	LVTTTL OUT	K2	RXD[4]	LVTTTL OUT
C5	RXRATE	LVTTTL IN PD	F9	REFCLK-	PECL IN	K3	VCC	POWER
C6	SDASEL	3-LEVEL SEL	F10	REFCLK+	PECL IN	K4	RXCLK+	LVTTTL OUT
C7	SPDSEL	3-LEVEL SEL	G1	RXOP	LVTTTL 3-S OUT	K5	TXD[7]	LVTTTL IN
C8	PARCTL	3-LEVEL SEL	G2	RXD[1]	LVTTTL OUT	K6	TXD[4]	LVTTTL IN
C9	RFMODE	3-LEVEL SEL	G3	RXD[5]	LVTTTL OUT	K7	TXD[1]	LVTTTL IN
C10	INSEL	LVTTTL IN	G4	GND	GROUND	K8	VCC	POWER
D1	BOE[0]	LVTTTL IN PU	G5	GND	GROUND	K9	SCSEL	LVTTTL IN PD
D2	BOE[1]	LVTTTL IN PU	G6	GND	GROUND	K10	VCC	POWER
D3	FRAMCHAR	3-LEVEL SEL	G7	GND	GROUND			
D4	GND	GROUND	G8	TXOP	LVTTTL IN PU			

X3.230 Codes and Notation Conventions

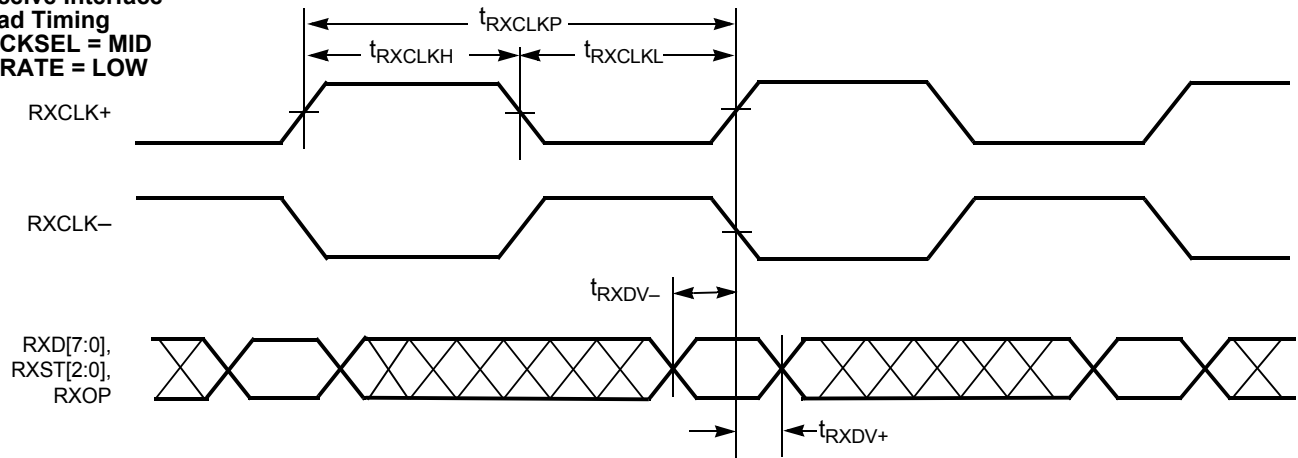
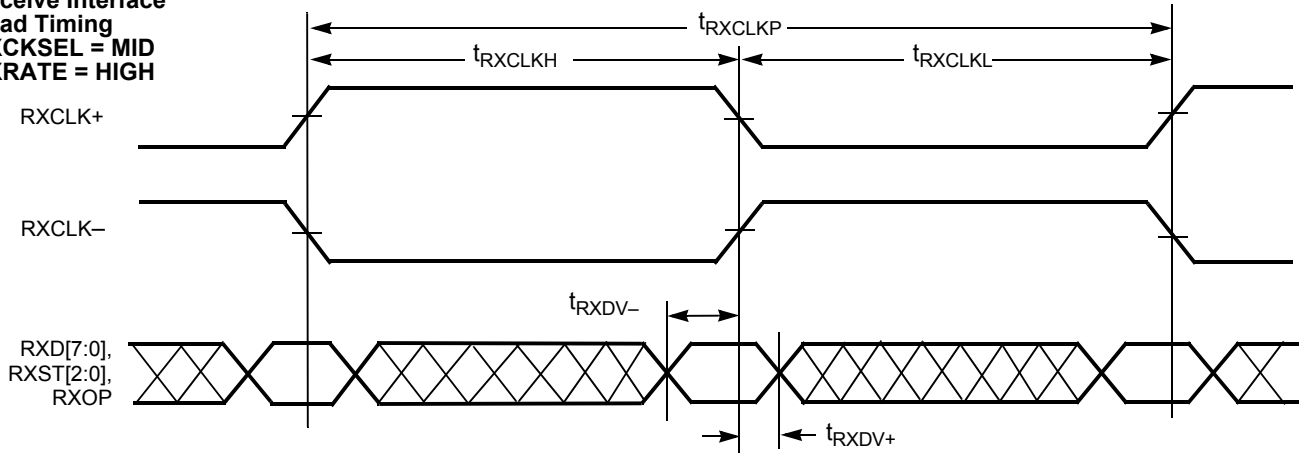
Information to be transmitted over a serial link is encoded eight bits at a time into a 10-bit Transmission Character and then sent serially, bit by bit. Information received over a serial link is collected ten bits at a time, and those Transmission Characters that are used for data characters are decoded into the correct eight-bit codes. The 10-bit Transmission Code supports all 256 eight-bit combinations. Some of the remaining Transmission Characters (Special Characters) are used for functions other than data transmission.

The primary use of a Transmission Code is to improve the transmission characteristics of a serial link. The encoding defined by the Transmission Code ensures that sufficient transitions are present in the serial bit stream to make clock recovery possible at the Receiver. Such encoding also greatly increases the likelihood of detecting any single or multiple bit errors that may occur during transmission and reception of information. In addition, some Special Characters of the Transmission Code selected by Fibre Channel Standard contain a distinct and easily recognizable bit pattern that assists the receiver in achieving character alignment on the incoming bit stream.

Notation Conventions

The documentation for the 8B/10B Transmission Code uses letter notation for the bits in an eight-bit byte. Fibre Channel Standard notation uses a bit notation of A, B, C, D, E, F, G, H for the eight-bit byte for the raw eight-bit data, and the letters a, b, c, d, e, i, f, g, h, j for encoded 10-bit data. There is a correspondence between bit A and bit a, B and b, C and c, D and d, E and e, F and f, G and g, and H and h. Bits i and j are derived, respectively, from (A,B,C,D,E) and (F,G,H).

The bit labeled A in the description of the 8B/10B Transmission Code corresponds to bit 0 in the numbering scheme of the FC-2 specification, B corresponds to bit 1, as shown below.

FC-2 bit designation—76543210
 HOTLink D/Q designation—76543210
 8B/10B bit designation—HGFEDCBA

To clarify this correspondence, the following example shows the conversion from an FC-2 Valid Data Byte to a Transmission Character.

```
FC-2  45H
      Bits: 7654 3210
           0100 0101
```

Converted to 8B/10B notation, note that the order of bits has been reversed):

```
Data Byte Name  D5.2
      Bits: ABCDE FGH
           10100 010
```

Translated to a transmission Character in the 8B/10B Transmission Code:

```
Bits: abcdei fghj
      101001 0101
```

Each valid Transmission Character of the 8B/10B Transmission Code has been given a name using the following convention: cxx.y, where c is used to show whether the Transmission Character is a Data Character (c is set to D, and SC/D = LOW) or a Special Character (c is set to K, and SC/D = HIGH). When

c is set to D, xx is the decimal value of the binary number composed of the bits E, D, C, B, and A in that order, and the y is the decimal value of the binary number composed of the bits H, G, and F in that order. When c is set to K, xx and y are derived by comparing the encoded bit patterns of the Special Character to those patterns derived from encoded Valid Data bytes and selecting the names of the patterns most similar to the encoded bit patterns of the Special Character.

Under the above conventions, the Transmission Character used for the examples above, is referred to by the name D5.2. The Special Character K29.7 is so named because the first six bits (abcdei) of this character make up a bit pattern similar to that resulting from the encoding of the unencoded 11101 pattern (29), and because the second four bits (fghj) make up a bit pattern similar to that resulting from the encoding of the unencoded 111 pattern (7). This definition of the 10-bit Transmission Code is based on the following references.

A.X. Widmer and P.A. Franaszek. "A DC-Balanced, Partitioned-Block, 8B/10B Transmission Code" IBM Journal of Research and Development, 27, No. 5: 440-451 (September, 1983).

U.S. Patent 4,486,739. Peter A. Franaszek and Albert X. Widmer. "Byte-Oriented DC Balanced (0.4) 8B/10B Partitioned Block Transmission Code" (December 4, 1984).

Fibre Channel Physical and Signaling Interface (ANSI X3.230-1994 ANSI FC-PH Standard).

IBM Enterprise Systems Architecture/390 ESCON I/O Interface (document number SA22-7202).

8B/10B Transmission Code

The following information describes how the tables are used for both generating valid Transmission Characters (encoding) and checking the validity of received Transmission Characters (decoding). It also specifies the ordering rules to be followed when transmitting the bits within a character and the characters within any higher-level constructs specified by a standard.

Transmission Order

Within the definition of the 8B/10B Transmission Code, the bit positions of the Transmission Characters are labeled a, b, c, d, e, i, f, g, h, j. Bit "a" is transmitted first followed by bits b, c, d, e, i, f, g, h, and j in that order.

Note that bit i is transmitted between bit e and bit f, rather than in alphabetical order.

Valid and Invalid Transmission Characters

The following tables define the valid Data Characters and valid Special Characters (K characters), respectively. The tables are used for both generating valid Transmission Characters and checking the validity of received Transmission Characters. In the tables, each Valid-Data-byte or Special-Character-code entry has two columns that represent two Transmission Characters. The two columns correspond to the current value of the running disparity. Running disparity is a binary parameter with either a negative (-) or positive (+) value.

After powering on, the Transmitter may assume either a positive or negative value for its initial running disparity. Upon transmission of any Transmission Character, the transmitter will select the proper version of the Transmission Character based on the current running disparity value, and the Transmitter

calculates a new value for its running disparity based on the contents of the transmitted character. Special Character codes C1.7 and C2.7 can be used to force the transmission of a specific Special Character with a specific running disparity as required for some special sequences in X3.230.

After powering on, the Receiver may assume either a positive or negative value for its initial running disparity. Upon reception of any Transmission Character, the Receiver decides whether the Transmission Character is valid or invalid according to the following rules and tables and calculates a new value for its Running Disparity based on the contents of the received character.

The following rules for running disparity are used to calculate the new running-disparity value for Transmission Characters that have been transmitted (Transmitter's running disparity) and that have been received (Receiver's running disparity).

Running disparity for a Transmission Character is calculated from sub-blocks, where the first six bits (abcdei) form one sub-block and the second four bits (fghj) form the other sub-block. Running disparity at the beginning of the six-bit sub-block is the running disparity at the end of the previous Transmission Character. Running disparity at the beginning of the four-bit sub-block is the running disparity at the end of the six-bit sub-block. Running disparity at the end of the Transmission Character is the running disparity at the end of the four-bit sub-block.

Running disparity for the sub-blocks is calculated as follows:

1. Running disparity at the end of any sub-block is positive if the sub-block contains more ones than zeros. It is also positive at the end of the six-bit sub-block if the six-bit sub-block is 000111, and it is positive at the end of the four-bit sub-block if the four-bit sub-block is 0011.
2. Running disparity at the end of any sub-block is negative if the sub-block contains more zeros than ones. It is also negative at the end of the six-bit sub-block if the six-bit sub-block is 111000, and it is negative at the end of the four-bit sub-block if the four-bit sub-block is 1100.
3. Otherwise, running disparity at the end of the sub-block is the same as at the beginning of the sub-block.

Use of the Tables for Generating Transmission Characters

The appropriate entry in the table is found for the Valid Data byte or the Special Character byte for which a Transmission Character is to be generated (encoded). The current value of the Transmitter's running disparity is used to select the Transmission Character from its corresponding column. For each Transmission Character transmitted, a new value of the running

disparity is calculated. This new value is used as the Transmitter's current running disparity for the next Valid Data byte or Special Character byte to be encoded and transmitted. [Table 18](#) shows naming notations and examples of valid transmission characters.

Use of the Tables for Checking the Validity of Received Transmission Characters

The column corresponding to the current value of the Receiver's running disparity is searched for the received Transmission Character. If the received Transmission Character is found in the proper column, then the Transmission Character is valid and the Data byte or Special Character code is determined (decoded). If the received Transmission Character is not found in that column, then the Transmission Character is invalid. This is called a code violation. Independent of the Transmission Character's validity, the received Transmission Character is used to calculate a new value of running disparity. The new value is used as the Receiver's current running disparity for the next received Transmission Character.

Table 18. Valid Transmission Characters

Byte Name	Data		Hex Value
	D _{IN} or Q _{OUT}		
	765	43210	
D0.0	000	00000	00
D1.0	000	00001	01
D2.0	000	00010	02
.	.	.	.
.	.	.	.
D5.2	010	00101	45
.	.	.	.
.	.	.	.
D30.7	111	11110	FE
D31.7	111	11111	FF

Detection of a code violation does not necessarily show that the Transmission Character in which the code violation was detected is in error. Code violations may result from a prior error that altered the running disparity of the bit stream which did not result in a detectable error at the Transmission Character in which the error occurred. [Table 19](#) shows an example of this behavior.

Table 19. Code Violations Resulting from Prior Errors

	RD	Character	RD	Character	RD	Character	RD
Transmitted data character	–	D21.1	–	D10.2	–	D23.5	+
Transmitted bit stream	–	101010 1001	–	010101 0101	–	111010 1010	+
Bit stream after error	–	101010 1011	+	010101 0101	+	111010 1010	+
Decoded data character	–	D21.0	+	D10.2	+	Code Violation	+

Table 20. Valid Data Characters (TXCTx[0] = 0, RXSTx[2:0] = 000)

Data Byte Name	Bits	Current RD-	Current RD+	Data Byte Name	Bits	Current RD-	Current RD+
	HGF EDCBA	abcdei fghj	abcdei fghj		HGF EDCBA	abcdei fghj	abcdei fghj
D0.0	000 00000	100111 0100	011000 1011	D0.1	001 00000	100111 1001	011000 1001
D1.0	000 00001	011101 0100	100010 1011	D1.1	001 00001	011101 1001	100010 1001
D2.0	000 00010	101101 0100	010010 1011	D2.1	001 00010	101101 1001	010010 1001
D3.0	000 00011	110001 1011	110001 0100	D3.1	001 00011	110001 1001	110001 1001
D4.0	000 00100	110101 0100	001010 1011	D4.1	001 00100	110101 1001	001010 1001
D5.0	000 00101	101001 1011	101001 0100	D5.1	001 00101	101001 1001	101001 1001
D6.0	000 00110	011001 1011	011001 0100	D6.1	001 00110	011001 1001	011001 1001
D7.0	000 00111	111000 1011	000111 0100	D7.1	001 00111	111000 1001	000111 1001
D8.0	000 01000	111001 0100	000110 1011	D8.1	001 01000	111001 1001	000110 1001
D9.0	000 01001	100101 1011	100101 0100	D9.1	001 01001	100101 1001	100101 1001
D10.0	000 01010	010101 1011	010101 0100	D10.1	001 01010	010101 1001	010101 1001
D11.0	000 01011	110100 1011	110100 0100	D11.1	001 01011	110100 1001	110100 1001
D12.0	000 01100	001101 1011	001101 0100	D12.1	001 01100	001101 1001	001101 1001
D13.0	000 01101	101100 1011	101100 0100	D13.1	001 01101	101100 1001	101100 1001
D14.0	000 01110	011100 1011	011100 0100	D14.1	001 01110	011100 1001	011100 1001
D15.0	000 01111	010111 0100	101000 1011	D15.1	001 01111	010111 1001	101000 1001
D16.0	000 10000	011011 0100	100100 1011	D16.1	001 10000	011011 1001	100100 1001
D17.0	000 10001	100011 1011	100011 0100	D17.1	001 10001	100011 1001	100011 1001
D18.0	000 10010	010011 1011	010011 0100	D18.1	001 10010	010011 1001	010011 1001
D19.0	000 10011	110010 1011	110010 0100	D19.1	001 10011	110010 1001	110010 1001
D20.0	000 10100	001011 1011	001011 0100	D20.1	001 10100	001011 1001	001011 1001
D21.0	000 10101	101010 1011	101010 0100	D21.1	001 10101	101010 1001	101010 1001
D22.0	000 10110	011010 1011	011010 0100	D22.1	001 10110	011010 1001	011010 1001
D23.0	000 10111	111010 0100	000101 1011	D23.1	001 10111	111010 1001	000101 1001
D24.0	000 11000	110011 0100	001100 1011	D24.1	001 11000	110011 1001	001100 1001
D25.0	000 11001	100110 1011	100110 0100	D25.1	001 11001	100110 1001	100110 1001
D26.0	000 11010	010110 1011	010110 0100	D26.1	001 11010	010110 1001	010110 1001
D27.0	000 11011	110110 0100	001001 1011	D27.1	001 11011	110110 1001	001001 1001
D28.0	000 11100	001110 1011	001110 0100	D28.1	001 11100	001110 1001	001110 1001
D29.0	000 11101	101110 0100	010001 1011	D29.1	001 11101	101110 1001	010001 1001
D30.0	000 11110	011110 0100	100001 1011	D30.1	001 11110	011110 1001	100001 1001
D31.0	000 11111	101011 0100	010100 1011	D31.1	001 11111	101011 1001	010100 1001
D0.2	010 00000	100111 0101	011000 0101	D0.3	011 00000	100111 0011	011000 1100
D1.2	010 00001	011101 0101	100010 0101	D1.3	011 00001	011101 0011	100010 1100
D2.2	010 00010	101101 0101	010010 0101	D2.3	011 00010	101101 0011	010010 1100

Table 20. Valid Data Characters (TXCTx[0] = 0, RXSTx[2:0] = 000) (continued)

Data Byte Name	Bits	Current RD-	Current RD+	Data Byte Name	Bits	Current RD-	Current RD+
	HGF EDCBA	abcdei fghj	abcdei fghj		HGF EDCBA	abcdei fghj	abcdei fghj
D3.2	010 00011	110001 0101	110001 0101	D3.3	011 00011	110001 1100	110001 0011
D4.2	010 00100	110101 0101	001010 0101	D4.3	011 00100	110101 0011	001010 1100
D5.2	010 00101	101001 0101	101001 0101	D5.3	011 00101	101001 1100	101001 0011
D6.2	010 00110	011001 0101	011001 0101	D6.3	011 00110	011001 1100	011001 0011
D7.2	010 00111	111000 0101	000111 0101	D7.3	011 00111	111000 1100	000111 0011
D8.2	010 01000	111001 0101	000110 0101	D8.3	011 01000	111001 0011	000110 1100
D9.2	010 01001	100101 0101	100101 0101	D9.3	011 01001	100101 1100	100101 0011
D10.2	010 01010	010101 0101	010101 0101	D10.3	011 01010	010101 1100	010101 0011
D11.2	010 01011	110100 0101	110100 0101	D11.3	011 01011	110100 1100	110100 0011
D12.2	010 01100	001101 0101	001101 0101	D12.3	011 01100	001101 1100	001101 0011
D13.2	010 01101	101100 0101	101100 0101	D13.3	011 01101	101100 1100	101100 0011
D14.2	010 01110	011100 0101	011100 0101	D14.3	011 01110	011100 1100	011100 0011
D15.2	010 01111	010111 0101	101000 0101	D15.3	011 01111	010111 0011	101000 1100
D16.2	010 10000	011011 0101	100100 0101	D16.3	011 10000	011011 0011	100100 1100
D17.2	010 10001	100011 0101	100011 0101	D17.3	011 10001	100011 1100	100011 0011
D18.2	010 10010	010011 0101	010011 0101	D18.3	011 10010	010011 1100	010011 0011
D19.2	010 10011	110010 0101	110010 0101	D19.3	011 10011	110010 1100	110010 0011
D20.2	010 10100	001011 0101	001011 0101	D20.3	011 10100	001011 1100	001011 0011
D21.2	010 10101	101010 0101	101010 0101	D21.3	011 10101	101010 1100	101010 0011
D22.2	010 10110	011010 0101	011010 0101	D22.3	011 10110	011010 1100	011010 0011
D23.2	010 10111	111010 0101	000101 0101	D23.3	011 10111	111010 0011	000101 1100
D24.2	010 11000	110011 0101	001100 0101	D24.3	011 11000	110011 0011	001100 1100
D25.2	010 11001	100110 0101	100110 0101	D25.3	011 11001	100110 1100	100110 0011
D26.2	010 11010	010110 0101	010110 0101	D26.3	011 11010	010110 1100	010110 0011
D27.2	010 11011	110110 0101	001001 0101	D27.3	011 11011	110110 0011	001001 1100
D28.2	010 11100	001110 0101	001110 0101	D28.3	011 11100	001110 1100	001110 0011
D29.2	010 11101	101110 0101	010001 0101	D29.3	011 11101	101110 0011	010001 1100
D30.2	010 11110	011110 0101	100001 0101	D30.3	011 11110	011110 0011	100001 1100
D31.2	010 11111	101011 0101	010100 0101	D31.3	011 11111	101011 0011	010100 1100
D0.4	100 00000	100111 0010	011000 1101	D0.5	101 00000	100111 1010	011000 1010
D1.4	100 00001	011101 0010	100010 1101	D1.5	101 00001	011101 1010	100010 1010
D2.4	100 00010	101101 0010	010010 1101	D2.5	101 00010	101101 1010	010010 1010
D3.4	100 00011	110001 1101	110001 0010	D3.5	101 00011	110001 1010	110001 1010
D4.4	100 00100	110101 0010	001010 1101	D4.5	101 00100	110101 1010	001010 1010
D5.4	100 00101	101001 1101	101001 0010	D5.5	101 00101	101001 1010	101001 1010
D6.4	100 00110	011001 1101	011001 0010	D6.5	101 00110	011001 1010	011001 1010

Table 20. Valid Data Characters (TXCTx[0] = 0, RXSTx[2:0] = 000) (continued)

Data Byte Name	Bits	Current RD-	Current RD+	Data Byte Name	Bits	Current RD-	Current RD+
	HGF EDCBA	abcdei fghj	abcdei fghj		HGF EDCBA	abcdei fghj	abcdei fghj
D7.4	100 00111	111000 1101	000111 0010	D7.5	101 00111	111000 1010	000111 1010
D8.4	100 01000	111001 0010	000110 1101	D8.5	101 01000	111001 1010	000110 1010
D9.4	100 01001	100101 1101	100101 0010	D9.5	101 01001	100101 1010	100101 1010
D10.4	100 01010	010101 1101	010101 0010	D10.5	101 01010	010101 1010	010101 1010
D11.4	100 01011	110100 1101	110100 0010	D11.5	101 01011	110100 1010	110100 1010
D12.4	100 01100	001101 1101	001101 0010	D12.5	101 01100	001101 1010	001101 1010
D13.4	100 01101	101100 1101	101100 0010	D13.5	101 01101	101100 1010	101100 1010
D14.4	100 01110	011100 1101	011100 0010	D14.5	101 01110	011100 1010	011100 1010
D15.4	100 01111	010111 0010	101000 1101	D15.5	101 01111	010111 1010	101000 1010
D16.4	100 10000	011011 0010	100100 1101	D16.5	101 10000	011011 1010	100100 1010
D17.4	100 10001	100011 1101	100011 0010	D17.5	101 10001	100011 1010	100011 1010
D18.4	100 10010	010011 1101	010011 0010	D18.5	101 10010	010011 1010	010011 1010
D19.4	100 10011	110010 1101	110010 0010	D19.5	101 10011	110010 1010	110010 1010
D20.4	100 10100	001011 1101	001011 0010	D20.5	101 10100	001011 1010	001011 1010
D21.4	100 10101	101010 1101	101010 0010	D21.5	101 10101	101010 1010	101010 1010
D22.4	100 10110	011010 1101	011010 0010	D22.5	101 10110	011010 1010	011010 1010
D23.4	100 10111	111010 0010	000101 1101	D23.5	101 10111	111010 1010	000101 1010
D24.4	100 11000	110011 0010	001100 1101	D24.5	101 11000	110011 1010	001100 1010
D25.4	100 11001	100110 1101	100110 0010	D25.5	101 11001	100110 1010	100110 1010
D26.4	100 11010	010110 1101	010110 0010	D26.5	101 11010	010110 1010	010110 1010
D27.4	100 11011	110110 0010	001001 1101	D27.5	101 11011	110110 1010	001001 1010
D28.4	100 11100	001110 1101	001110 0010	D28.5	101 11100	001110 1010	001110 1010
D29.4	100 11101	101110 0010	010001 1101	D29.5	101 11101	101110 1010	010001 1010
D30.4	100 11110	011110 0010	100001 1101	D30.5	101 11110	011110 1010	100001 1010
D31.4	100 11111	101011 0010	010100 1101	D31.5	101 11111	101011 1010	010100 1010
D0.6	110 00000	100111 0110	011000 0110	D0.7	111 00000	100111 0001	011000 1110
D1.6	110 00001	011101 0110	100010 0110	D1.7	111 00001	011101 0001	100010 1110
D2.6	110 00010	101101 0110	010010 0110	D2.7	111 00010	101101 0001	010010 1110
D3.6	110 00011	110001 0110	110001 0110	D3.7	111 00011	110001 1110	110001 0001
D4.6	110 00100	110101 0110	001010 0110	D4.7	111 00100	110101 0001	001010 1110
D5.6	110 00101	101001 0110	101001 0110	D5.7	111 00101	101001 1110	101001 0001
D6.6	110 00110	011001 0110	011001 0110	D6.7	111 00110	011001 1110	011001 0001
D7.6	110 00111	111000 0110	000111 0110	D7.7	111 00111	111000 1110	000111 0001
D8.6	110 01000	111001 0110	000110 0110	D8.7	111 01000	111001 0001	000110 1110
D9.6	110 01001	100101 0110	100101 0110	D9.7	111 01001	100101 1110	100101 0001
D10.6	110 01010	010101 0110	010101 0110	D10.7	111 01010	010101 1110	010101 0001

Table 20. Valid Data Characters (TXCTx[0] = 0, RXSTx[2:0] = 000) (continued)

Data Byte Name	Bits	Current RD-	Current RD+	Data Byte Name	Bits	Current RD-	Current RD+
	HGF EDCBA	abcdei fghj	abcdei fghj		HGF EDCBA	abcdei fghj	abcdei fghj
D11.6	110 01011	110100 0110	110100 0110	D11.7	111 01011	110100 1110	110100 1000
D12.6	110 01100	001101 0110	001101 0110	D12.7	111 01100	001101 1110	001101 0001
D13.6	110 01101	101100 0110	101100 0110	D13.7	111 01101	101100 1110	101100 1000
D14.6	110 01110	011100 0110	011100 0110	D14.7	111 01110	011100 1110	011100 1000
D15.6	110 01111	010111 0110	101000 0110	D15.7	111 01111	010111 0001	101000 1110
D16.6	110 10000	011011 0110	100100 0110	D16.7	111 10000	011011 0001	100100 1110
D17.6	110 10001	100011 0110	100011 0110	D17.7	111 10001	100011 0111	100011 0001
D18.6	110 10010	010011 0110	010011 0110	D18.7	111 10010	010011 0111	010011 0001
D19.6	110 10011	110010 0110	110010 0110	D19.7	111 10011	110010 1110	110010 0001
D20.6	110 10100	001011 0110	001011 0110	D20.7	111 10100	001011 0111	001011 0001
D21.6	110 10101	101010 0110	101010 0110	D21.7	111 10101	101010 1110	101010 0001
D22.6	110 10110	011010 0110	011010 0110	D22.7	111 10110	011010 1110	011010 0001
D23.6	110 10111	111010 0110	000101 0110	D23.7	111 10111	111010 0001	000101 1110
D24.6	110 11000	110011 0110	001100 0110	D24.7	111 11000	110011 0001	001100 1110
D25.6	110 11001	100110 0110	100110 0110	D25.7	111 11001	100110 1110	100110 0001
D26.6	110 11010	010110 0110	010110 0110	D26.7	111 11010	010110 1110	010110 0001
D27.6	110 11011	110110 0110	001001 0110	D27.7	111 11011	110110 0001	001001 1110
D28.6	110 11100	001110 0110	001110 0110	D28.7	111 11100	001110 1110	001110 0001
D29.6	110 11101	101110 0110	010001 0110	D29.7	111 11101	101110 0001	010001 1110
D30.6	110 11110	011110 0110	100001 0110	D30.7	111 11110	011110 0001	100001 1110
D31.6	110 11111	101011 0110	010100 0110	D31.7	111 11111	101011 0001	010100 1110

Table 21. Valid Special Character Codes and Sequences (TXCTx = Special Character Code or RXSTx[2:0] = 001)^[55,56]

S.C. Code Name	S.C. Byte Name					Current RD– abcdei fghj	Current RD+ abcdei fghj
	Cypress			Alternate			
	S.C. Byte Name ^[57]	Bits HGF EDCBA	S.C. Byte Name ^[57]	Bits HGF EDCBA			
K28.0	C0.0 (C00)	000 00000	C28.0 (C1C)	000 11100	001111 0100	110000 1011	
K28.1 ^[58]	C1.0 (C01)	000 00001	C28.1 (C3C)	001 11100	001111 1001	110000 0110	
K28.2 ^[58]	C2.0 (C02)	000 00010	C28.2 (C5C)	010 11100	001111 0101	110000 1010	
K28.3	C3.0 (C03)	000 00011	C28.3 (C7C)	011 11100	001111 0011	110000 1100	
K28.4 ^[58]	C4.0 (C04)	000 00100	C28.4 (C9C)	100 11100	001111 0010	110000 1101	
K28.5 ^[58, 59]	C5.0 (C05)	000 00101	C28.5 (CBC)	101 11100	001111 1010	110000 0101	
K28.6 ^[58]	C6.0 (C06)	000 00110	C28.6 (CDC)	110 11100	001111 0110	110000 1001	
K28.7 ^[58, 60]	C7.0 (C07)	000 00111	C28.7 (CFC)	111 11100	001111 1000	110000 0111	
K23.7	C8.0 (C08)	000 01000	C23.7 (CF7)	111 10111	111010 1000	000101 0111	
K27.7	C9.0 (C09)	000 01001	C27.7 (CFB)	111 11011	110110 1000	001001 0111	
K29.7	C10.0 (C0A)	000 01010	C29.7 (CFD)	111 11101	101110 1000	010001 0111	
K30.7	C11.0 (C0B)	000 01011	C30.7 (CFE)	111 11110	011110 1000	100001 0111	
End of Frame Sequence							
EOFxx ^[61]	C2.1 (C22)	001 00010	C2.1 (C22)	001 00010	–K28.5,Dn.xxx0	+K28.5,Dn.xxx1	
Code Rule Violation and SVS Tx Pattern							
Exception ^[60, 62]	C0.7 (CE0)	111 00000	C0.7 (CE0)	111 00000 ^[66]	100111 1000	011000 0111	
–K28.5 ^[63]	C1.7 (CE1)	111 00001	C1.7 (CE1)	111 00001 ^[66]	001111 1010	001111 1010	
+K28.5 ^[64]	C2.7 (CE2)	111 00010	C2.7 (CE2)	111 00010 ^[66]	110000 0101	110000 0101	
Running Disparity Violation Pattern							
Exception ^[65]	C4.7 (CE4)	111 00100	C4.7 (CE4)	111 00100 ^[66]	110111 0101	001000 1010	

Notes

55. All codes not shown are reserved.
56. Notation for Special Character Code Name is consistent with Fibre Channel and ESCON naming conventions. Special Character Code Name is intended to describe binary information present on I/O pins. Common usage for the name can either be in the form used for describing Data patterns (i.e., C0.0 through C31.7), or in hex notation (i.e., Cnn where nn = the specified value between 00 and FF).
57. Both the Cypress and alternate encodings may be used for data transmission to generate specific Special Character Codes. The decoding process for received characters generates Cypress codes or Alternate codes as selected by the DECMODE configuration input.
58. These characters are used for control of ESCON interfaces. They can be sent as embedded commands or other markers when not operating using ESCON protocols.
59. The K28.5 character is used for framing operations by the receiver. It is also the pad or fill character transmitted to maintain the serial link when no user data is available.
60. Care must be taken when using this Special Character code. When a K28.7(C7.0) or SVS(C0.7) is followed by a D11.x or D20.x, an alias K28.5 sync character is created. These sequences can cause erroneous framing and should be avoided while RFEN = HIGH.
61. C2.1 = Transmit either –K28.5+ or +K28.5– as determined by Current RD and modify the Transmission Character that follows, by setting its least significant bit to 1 or 0. If Current RD at the start of the following character is plus (+) the LSB is set to 0, and if Current RD is minus (–) the LSB becomes 1. This modification allows construction of X3.230 “EOF” frame delimiters wherein the second data byte is determined by the Current RD. For example, to send “EOFdt” the controller could issue the sequence C2.1–D21.4– D21.4–D21.4, and the HOTLink Transmitter will send either K28.5–D21.4–D21.4–D21.4 or K28.5–D21.5– D21.4–D21.4 based on Current RD. Likewise to send “EOFdti” the controller could issue the sequence C2.1–D10.4–D21.4–D21.4, and the HOTLink Transmitter will send either K28.5–D10.4–D21.4– D21.4 or K28.5–D10.5–D21.4– D21.4 based on Current RD. The receiver will never output this Special Character, since K28.5 is decoded as C5.0, C1.7, or C2.7, and the subsequent bytes are decoded as data.
62. C0.7 = Transmit a deliberate code rule violation. The code chosen for this function follows the normal Running Disparity rules. The receiver will only output this Special Character if the Transmission Character being decoded is not found in the tables.
63. C1.7 = Transmit Negative K28.5 (–K28.5+) disregarding Current RD. The receiver will only output this Special Character if K28.5 is received with the wrong running disparity. The receiver will output C1.7 if –K28.5 is received with RD+, otherwise K28.5 is decoded as C5.0 or C2.7.
64. C2.7 = Transmit Positive K28.5 (+K28.5–) disregarding Current RD. The receiver will only output this Special Character if K28.5 is received with the wrong running disparity. The receiver will output C2.7 if +K28.5 is received with RD–, otherwise K28.5 is decoded as C5.0 or C1.7.
65. C4.7 = Transmit a deliberate code rule violation to indicate a Running Disparity violation. The receiver will only output this Special Character if the Transmission Character being decoded is found in the tables, but Running Disparity does not match. This might indicate that an error occurred in a prior byte.
66. Supported only for data transmission. The receive status for these conditions will be reported by specific combinations of receive status bits.

Ordering Information

Speed	Ordering Code	Package Name	Package Type	Operating Range
Standard	CYP15G0101DXB-BBXC	BB100	Pb-free 100-ball Grid Array	Commercial
Standard	CYP15G0101DXB-BBXI	BB100	Pb-free 100-ball Grid Array	Industrial
Standard	CYV15G0101DXB-BBXC	BB100	Pb-free 100-ball Grid Array	Commercial

Ordering Code Definitions

CY X15G0101 DXB - BB X X

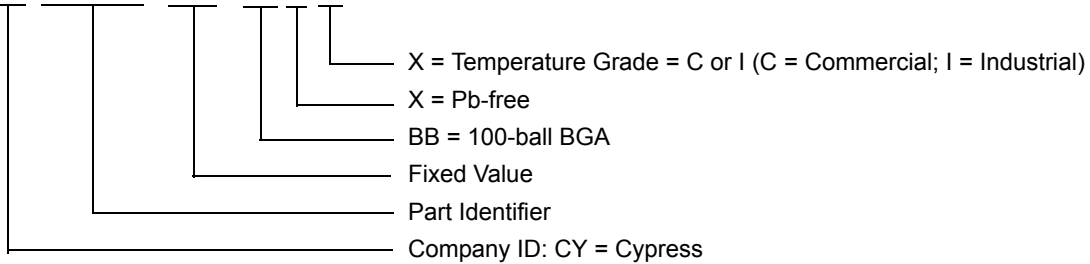

Package Diagram

Figure 3. 100-ball Thin BGA (11 × 11 × 1.4 mm) BB100 Package Outline, 51-85107

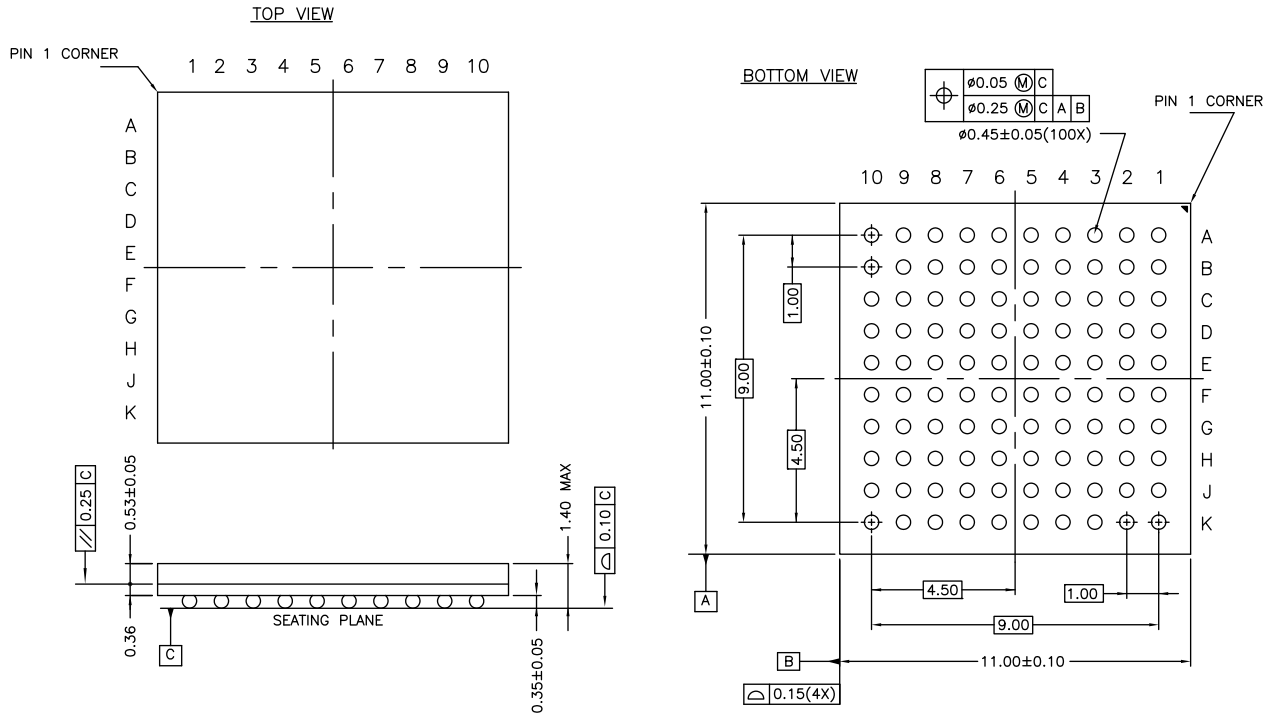

Package Weight – Refer to PMDD spec

51-85107 *E

Acronyms

Table 22. Acronyms Used in this Datasheet

Acronym	Description
BGA	ball grid array
BIST	built-in self test
I/O	input/output
JTAG	joint test action group
PLL	phase-locked loop
TMS	test mode select
TDO	test data out
TDI	test data in

Document Conventions

Units of Measure

Table 23. Units of Measure

Symbol	Unit of Measure
°C	degree Celsius
kΩ	kiloohm
μA	microampere
μs	microsecond
mA	milliampere
ms	millisecond
mV	millivolt
nA	nanoampere
Ω	ohm
pF	picofarad
V	volt
W	watt

Document History Page

Document Title: CYP15G0101DXB/CYV15G0101DXB, Single-channel HOTLink II™ Transceiver				
Document Number: 38-02031				
Revision	ECN	Submission Date	Orig. of Change	Description of Change
**	113123	05/20/02	TPS	New Data Sheet
*A	119704	10/30/02	LNМ	Changed TXPER description Changed TXCLKO description Changed RXCKSEL to include RXCLKC+ Removed disparity reference from RFMODE Removed the LOW setting for FRAMCHAR and related references Removed references to ATM transport Changed the I _{OST} boundary values Changed V _{ODIF} and V _{OLC} for CML output Changed the t _{TXCLKR} and t _{TXCLKF} min. values Changed t _{TXDS} , t _{TXDH} , t _{TREFFDS} , and t _{TREFFDH} Changed t _{REFDV-} , t _{REFCDV-} , and t _{REFCDV+} Changed the JTAG ID from 0C804069 to 1C804069 Added a section for characterization and standards compliance Changed I/O type of RXCLKC in I/O coordinates table
*B	122209	12/28/02	RBI	Minor Change Document Control corrected Document History Page
*C	122546	02/13/03	CGX	Changed Minimum tRISE/tFALL for CML Changed tRXLOCK Changed tDJ, tRJ Changed tJTOL Changed tTXLOCK Changed tRXCLKH, tRXCLKL Changed tTXCLKOD+, tTXCLKOD- Changed Power Specs Changed verbiage...Paragraph: Clock/Data Recovery Changed verbiage...Paragraph: Range Control Added Power-up Requirements
*D	124994	04/15/03	POT	Changed CYP15G0101DXB to CYP(V)15G0101DXB type corresponding to the Video-compliant parts Reduced the lower limit of the serial signaling rate from 200 Mbaud to 195 Mbaud and changed the associated specifications accordingly
*E	128366	7/3/03	PDS	Revised the value of t _{REFADV} , t _{REFADV+} and t _{REFCDV+}
*F	128835	7/31/03	KKV	Minor change: corrections due to editorial error - old file used for *E revision (reestablishing *D changes)
*G	131898	12/10/03	PDS	When TXCKSEL = MID or HIGH, TXRATE = HIGH is an invalid mode. Made appropriate changes to reflect this invalid condition Removed requirement of AC coupling for Serial I/Os for interfacing with LVPECL I/Os Changed LFI to Asynchronous output Expanded the CDR Range Controller's permissible frequency offset between incoming serial signaling rate and Reference clock from ±200-PPM to ±1500-PPM (changed parameter t _{REFRX})
*H	211461	See ECN	KKV	Minor change: Package diagram isn't legible in pdf
*I	230621	See ECN	LAR	Updated package information in features list to reflect correct package
*J	338721	See ECN	SUA	Added CYW15G0101DXB part number for OBSAI RP3 compliance to support operating data rate upto 1540 MBaud. Made changes to reflect OBSAI RP3 and CPR compliance. Added Pb-Free Package option for all parts listed in the datasheet. Changed MBd to MBaud in SPDSEL pin description

Document History Page *(continued)*

Document Title: CYP15G0101DXB/CYV15G0101DXB, Single-channel HOTLink II™ Transceiver Document Number: 38-02031				
Revision	ECN	Submission Date	Orig. of Change	Description of Change
*K	2898355	03/24/2010	CGX	Removed inactive parts from Ordering Information. Updated Packaging Information.
*L	3053045	10/08/2010	CGX	Updated Ordering Information and added Ordering Code Definitions . Added Acronyms and Document Conventions . Minor edits and updated in new template.
*M	3243269	04/28/2011	SAAC	Removed the following part numbers from the Ordering Information on page 40 since the parts are no longer active. (CDT 98703) a) CYP15G0101DXB-BBI b) CYV15G0101DXB-BBI c) CYW15G0101DXB-BBXI Removed all references to the part CYW15G0101DXB from the datasheet (CDT 98703).
*N	3589088	04/17/2012	SAAC	Removed the part number CYP15G0101DXB-BBC from the Ordering Information on page 40 as the part is no longer active. Updated Package Diagram 51-85107 (from Rev *C to *D).
*O	4749016	04/30/2015	YLIU	Updated Package Diagram : spec 51-85107 – Changed revision from *D to *E. Updated to new template. Completing Sunset Review.
*P	5962424	11/09/2017	AESATMP8	Updated logo and Copyright.

Sales, Solutions, and Legal Information

Worldwide Sales and Design Support

Cypress maintains a worldwide network of offices, solution centers, manufacturer's representatives, and distributors. To find the office closest to you, visit us at [Cypress Locations](#).

Products

ARM [®] Cortex [®] Microcontrollers	cypress.com/arm
Automotive	cypress.com/automotive
Clocks & Buffers	cypress.com/clocks
Interface	cypress.com/interface
Internet of Things	cypress.com/iot
Memory	cypress.com/memory
Microcontrollers	cypress.com/mcu
PSoC	cypress.com/psoc
Power Management ICs	cypress.com/pmhc
Touch Sensing	cypress.com/touch
USB Controllers	cypress.com/usb
Wireless Connectivity	cypress.com/wireless

PSoC[®] Solutions

[PSoC 1](#) | [PSoC 3](#) | [PSoC 4](#) | [PSoC 5LP](#) | [PSoC 6](#)

Cypress Developer Community

[Forums](#) | [WICED IOT Forums](#) | [Projects](#) | [Video](#) | [Blogs](#) | [Training](#) | [Components](#)

Technical Support

cypress.com/support

© Cypress Semiconductor Corporation, 2002-2017. This document is the property of Cypress Semiconductor Corporation and its subsidiaries, including Spansion LLC ("Cypress"). This document, including any software or firmware included or referenced in this document ("Software"), is owned by Cypress under the intellectual property laws and treaties of the United States and other countries worldwide. Cypress reserves all rights under such laws and treaties and does not, except as specifically stated in this paragraph, grant any license under its patents, copyrights, trademarks, or other intellectual property rights. If the Software is not accompanied by a license agreement and you do not otherwise have a written agreement with Cypress governing the use of the Software, then Cypress hereby grants you a personal, non-exclusive, nontransferable license (without the right to sublicense) (1) under its copyright rights in the Software (a) for Software provided in source code form, to modify and reproduce the Software solely for use with Cypress hardware products, only internally within your organization, and (b) to distribute the Software in binary code form externally to end users (either directly or indirectly through resellers and distributors), solely for use on Cypress hardware product units, and (2) under those claims of Cypress's patents that are infringed by the Software (as provided by Cypress, unmodified) to make, use, distribute, and import the Software solely for use with Cypress hardware products. Any other use, reproduction, modification, translation, or compilation of the Software is prohibited.

TO THE EXTENT PERMITTED BY APPLICABLE LAW, CYPRESS MAKES NO WARRANTY OF ANY KIND, EXPRESS OR IMPLIED, WITH REGARD TO THIS DOCUMENT OR ANY SOFTWARE OR ACCOMPANYING HARDWARE, INCLUDING, BUT NOT LIMITED TO, THE IMPLIED WARRANTIES OF MERCHANTABILITY AND FITNESS FOR A PARTICULAR PURPOSE. To the extent permitted by applicable law, Cypress reserves the right to make changes to this document without further notice. Cypress does not assume any liability arising out of the application or use of any product or circuit described in this document. Any information provided in this document, including any sample design information or programming code, is provided only for reference purposes. It is the responsibility of the user of this document to properly design, program, and test the functionality and safety of any application made of this information and any resulting product. Cypress products are not designed, intended, or authorized for use as critical components in systems designed or intended for the operation of weapons, weapons systems, nuclear installations, life-support devices or systems, other medical devices or systems (including resuscitation equipment and surgical implants), pollution control or hazardous substances management, or other uses where the failure of the device or system could cause personal injury, death, or property damage ("Unintended Uses"). A critical component is any component of a device or system whose failure to perform can be reasonably expected to cause the failure of the device or system, or to affect its safety or effectiveness. Cypress is not liable, in whole or in part, and you shall and hereby do release Cypress from any claim, damage, or other liability arising from or related to all Unintended Uses of Cypress products. You shall indemnify and hold Cypress harmless from and against all claims, costs, damages, and other liabilities, including claims for personal injury or death, arising from or related to any Unintended Uses of Cypress products.

Cypress, the Cypress logo, Spansion, the Spansion logo, and combinations thereof, WICED, PSoC, CapSense, EZ-USB, F-RAM, and Traveo are trademarks or registered trademarks of Cypress in the United States and other countries. For a more complete list of Cypress trademarks, visit cypress.com. Other names and brands may be claimed as property of their respective owners.