

Product Specification

10 GBPS 1310NM PIN + PREAMP LC ROSA PACKAGE

PIN-1310-10LR-LC

PRODUCT FEATURES

- LC ROSA PIN-1310-10LR-LC includes flex circuit
- High performance InGaAs PIN photodiode with separate transimpedance amplifier
- Low electrical parasitic TO46 package
- Data rates up to 11.3Gbps
- Separate PD supply for power monitoring
- Low bias currents and voltages
- Low power dissipation
- IEEE 10G-BASE-LR applications

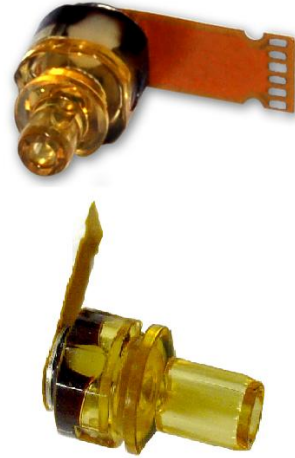

The PIN-1310-10LR-LC uses a high-performance InGaAs PIN photo-detector packaged with a transimpedance amplifier designed to meet performance requirements for data rates up to 11.3Gbps data communication over singlemode and multi-mode optical fiber at 1310nm. Applications include Ethernet, Fiber Channel and ATM protocols. The optical assembly is designed to interface to single mode optical fiber.

The PIN-1310-10LR-LC is designed to be paired with Finisar FP and DFB TOSA products (see data sheets for FP-1310 and DFB-1310 and products). The PIN is RoHS compliant per Directive 2011/65/EU¹.

PRODUCT SELECTION

Part Number	Description
N-1310-10LR-LC	pin LC ROSA, with separate PD bias, with flex circuit

I. Absolute Maximum Ratings

Parameter	Rating
Storage Temperature	-40 to +85°C
Case Operating Temperature	-10 to +85°C
Lead Solder Temperature	260°C, 10 sec.
Power Supply Voltage	-0.5V to 4V
Incident Optical Power	+3 dBm average, +5 dBm peak
Storage Temperature	-40 to +85°C

Notice

Stresses greater than those listed under “Absolute Maximum Ratings” may cause permanent damage to the device. This is a stress rating only and functional operation of the device at these or any other conditions above those indicated in the operations section for extended periods of time may affect reliability.

Notice

The inherent design of this component causes it to be sensitive to electrostatic discharge (ESD). To prevent ESD-induced damage and/or degradation to equipment, take normal ESD precautions when handling this product



II. Electro-Optical Characteristics (3.0V<V_{cc}<3.6V, AC coupled to 50Ω (100Ω differential), -10°C<T<85°C unless otherwise specified, with flex)

Parameters	Test Condition	Symbol	Min.	Typ.	Max.	Units	Notes
Data Rate		DR	0.1		11.3	Gbps	
Supply Voltage			3.0	3.3	3.6	V	
Supply Current	P _R = 0μW, R _L = 50Ω AC coupled	I _{CC}		35	60	mA	1
Optical Return Loss	P _R = -12dBm	ORL	12			dB	1
Input Optical Wavelength		λ _P	1260		1620	nm	
PD Responsivity	λ = 1310nm	Resp	0.8	0.85		A/W	1
PD Bias		V _{PD}	3.0	3.3	3.6		
Maximum Average Input Power before Overload		P _{MAX}	+1	+3		dBm	
Differential Output Voltage Swing	P _{R,OMA} = -12Bm, AC Coupled to R _L = 50Ω	V _{o(pk-pk)}	100		600	mV	1,2
Differential Responsivity	P _{R,OMA} = -12dBm, AC Coupled to R _L = 50Ω	T	1500			V/W	1,2
-3dB Optical/Electrical Bandwidth	T _A = 25°C	BW	7.5			GHz	1,2,3
Low Frequency -3dB Cutoff		BW _{LF}			30	KHz	1,2,3
Output Impedance		Z _{OUT}	40	50	60	Ω	
Output Return Loss	R ₀ = 50Ω, DC 10 ≤ GHZ	S ₂₂			-7	dB	
Sensitivity	DR = 10.3125Gbps	S			-16.5	dBm	4
Stressed Sensitivity	Circadiant Test	S _{STRESS}			-12	dBm	4
Rise/Fall Time	P _{R,OMA} = -12dBm, (20%-80%),	T _R /T _F			45	ps	2,5
Differential Power Supply Rejection Ratio	P _R = 0μW (Dark), 5MHz < F < 2GHz	PSRR	20			dB	1,6
Group Delay	P _{R,OMA} = -12dBm, AC Coupled to R _L = 50Ω 2MHz < F < 6GHz	Delay	-50		50	ps	7

Notes:

1. P_R is the average optical power at the fiber face.
2. P_{R,OMA} is the peak to peak optical power at the fiber face (Optical Modulation Amplitude)

$$P_{R,OMA} \equiv \frac{2P_R(ER-1)}{ER+1} \text{ where ER is the extinction ratio (linear) of the optical source.}$$

3. Bandwidth and Low Frequency Cutoff are measured with a small signal sinusoidal light source with -10dBm average power
4. Sensitivity is measured with an optical source with an extinction ratio of 6dB. For sensitivity measurements at 10.3125, 10.51875, 10.70923, 11.09573, 11.31764 Gb/s, PRBS 2³¹-1, ER=6dB, BER < 10⁻¹² and with limiting of the TIA is assumed to be implemented at the front end of the post amplifier. Stress testing is done using a Circadiant test system
5. Rise/Fall times are corrected for optical source Rise/Fall times. $T_{TIA}^2 = T_{MEASURED}^2 - T_{OPTICAL}^2$
6. Value shown is with no external power supply filtering.
7. Group delay is a sensitive measurement to package interface, and includes the effects of PD, TIA and package. Measurement is made with TO leads as short as possible.
8. DJ_{TIA} is specified as contributed DJ by the TIA, obtained from $DJ_{TIA}^2 = DJ_{TOTAL}^2 - DJ_{OPTICAL}^2$
9. RJ_{TIA} is specified as contributed RJ by the TIA, obtained from $RJ_{TIA}^2 = RJ_{TOTAL}^2 - RJ_{OPTICAL}^2$
10. The electrical performance of the ROSA is dependent upon the quality of the electrical connection between the TO can and the circuit board. AOC cannot guarantee all performance specifications for parts without the flex circuit attached.

III. Environmental Specifications

Parameter	Symbol	Min	Typ	Max	Units	Ref.
Case Operating Temperature	T _{op}	-10		85	°C	
Storage Temperature	T _{sto}	-40		85	°C	

IV. Mechanical Specifications

PIN	Description
1	V _{CC}
2	CASE
3	OUTP
4	OUTN
5	CASE
6	V _{PD}

(dimensions are in mm)

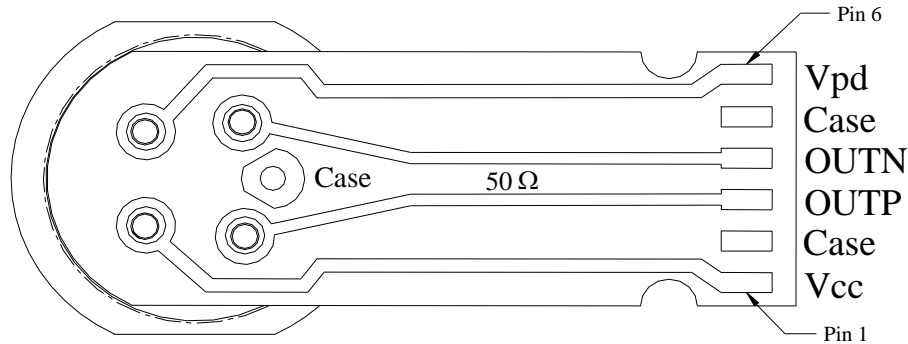

PIN-1310-10LR-XX

INTERFACE EXAMPLE

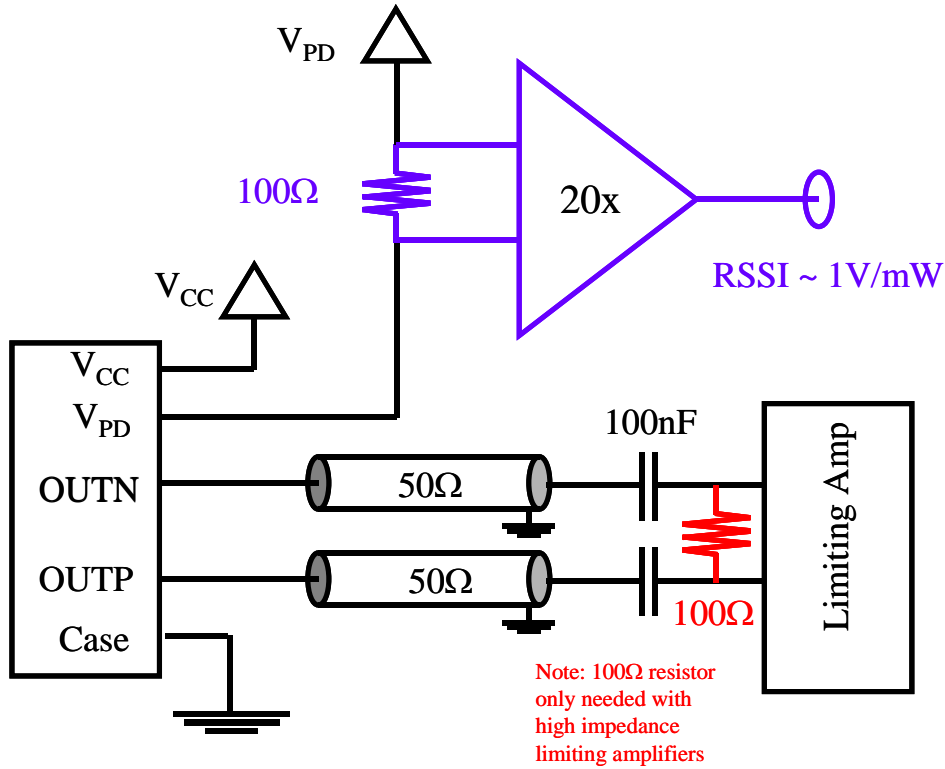

Optional 100Ω differential termination for high impedance limiting amplifiers is shown in red.

Recommended bias network

Note, better performance will be obtained if a ferrite bead is used in place of the inductor.

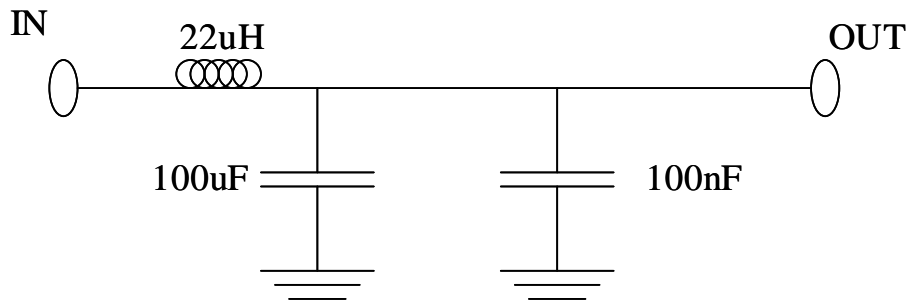

Mounting Dimensions (in mm)

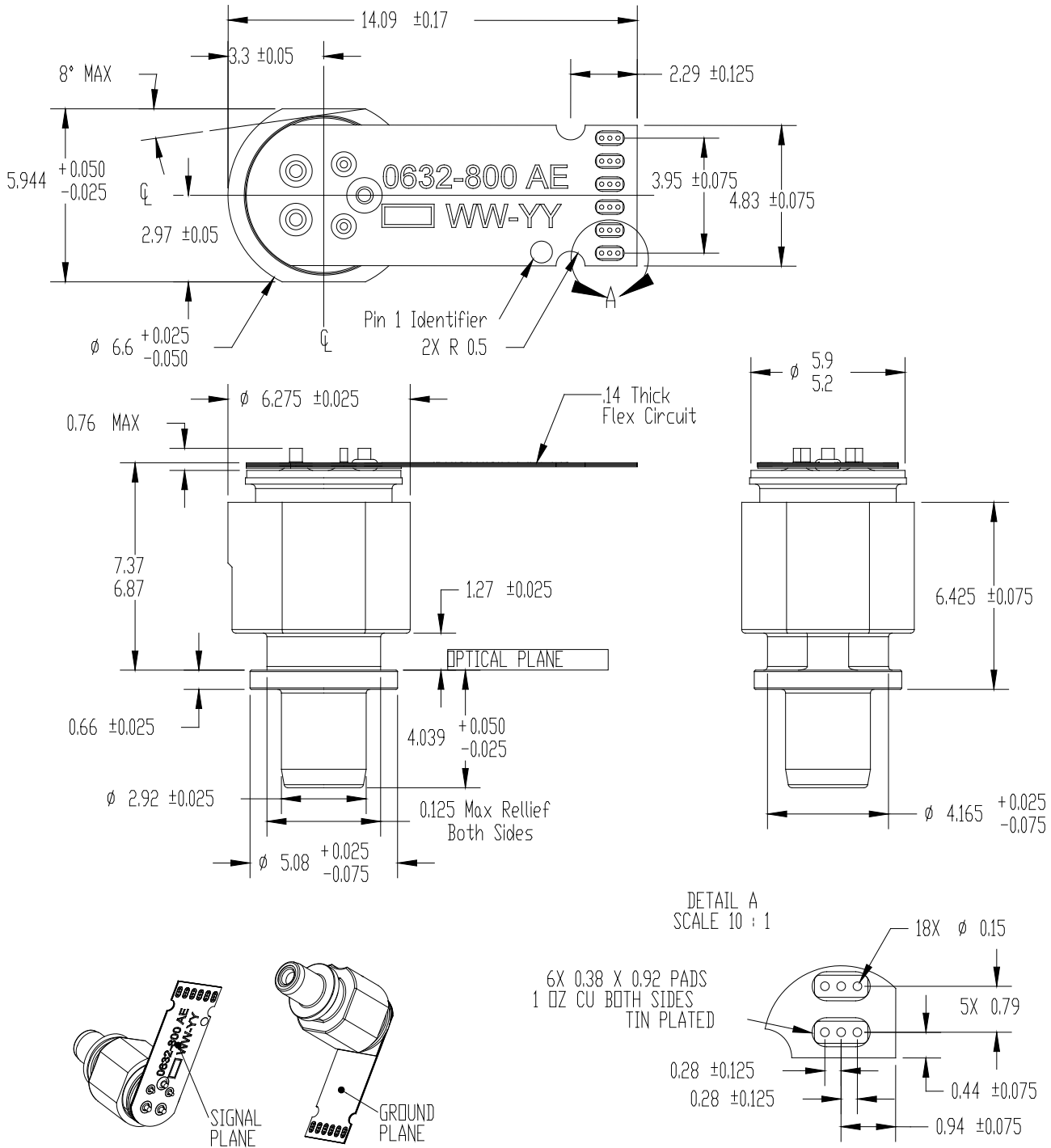

V. References

1. Directive 2011/65/EU of the European Parliament and of the Council, “on the restriction of the use of certain hazardous substances in electrical and electronic equipment”. Certain products may use one or more exemption as allowed by the Directive.

VI. Revision History

Revision	Date	Description
B00	10/14/2014	Converted to Finisar standard format.
C1	10/20/2015	Updated logo and RoHS statement.

VII. For More Information

Finisar Corporation
1389 Moffett Park Drive
Sunnyvale, CA 94089-1133
Tel. 1-408-548-1000
Fax 1-408-541-6138
sales@finisar.com
www.finisar.com