

LOC	DIST	REVISIONS			
P	LTR	DESCRIPTION	DATE	DWN	APVD
	C1	REVISED PER ECO-14-010107	03JUL2014	JA	DM
	C2	REVISED PER ECO-16-006330	24MAR2016	VNB	DM

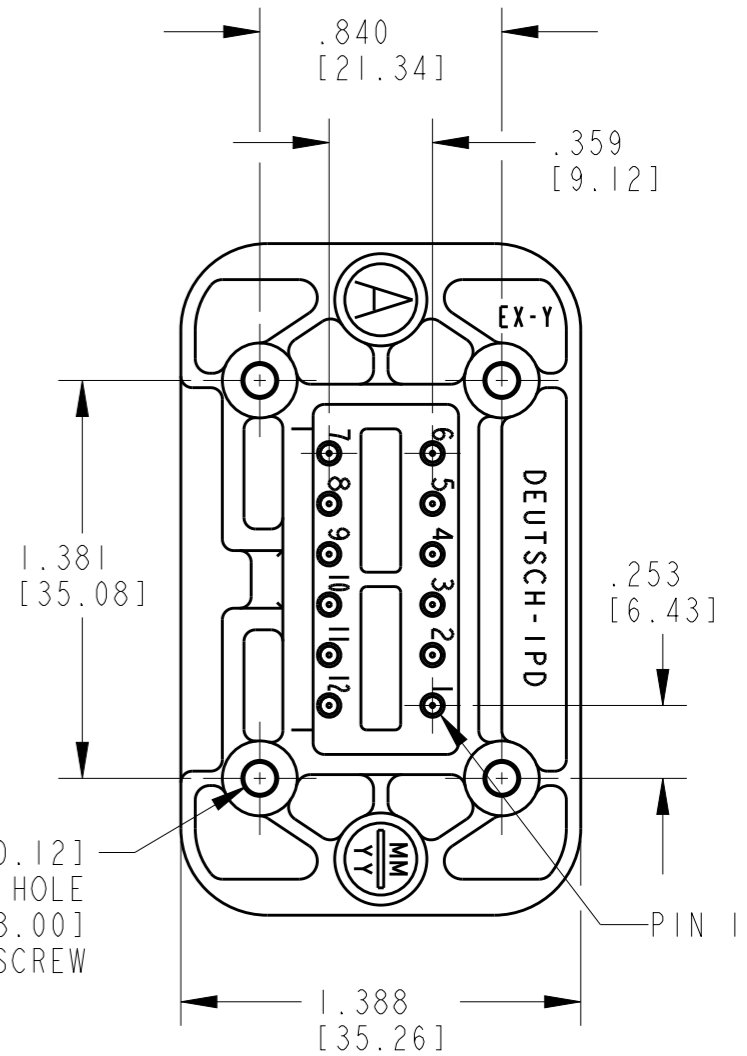
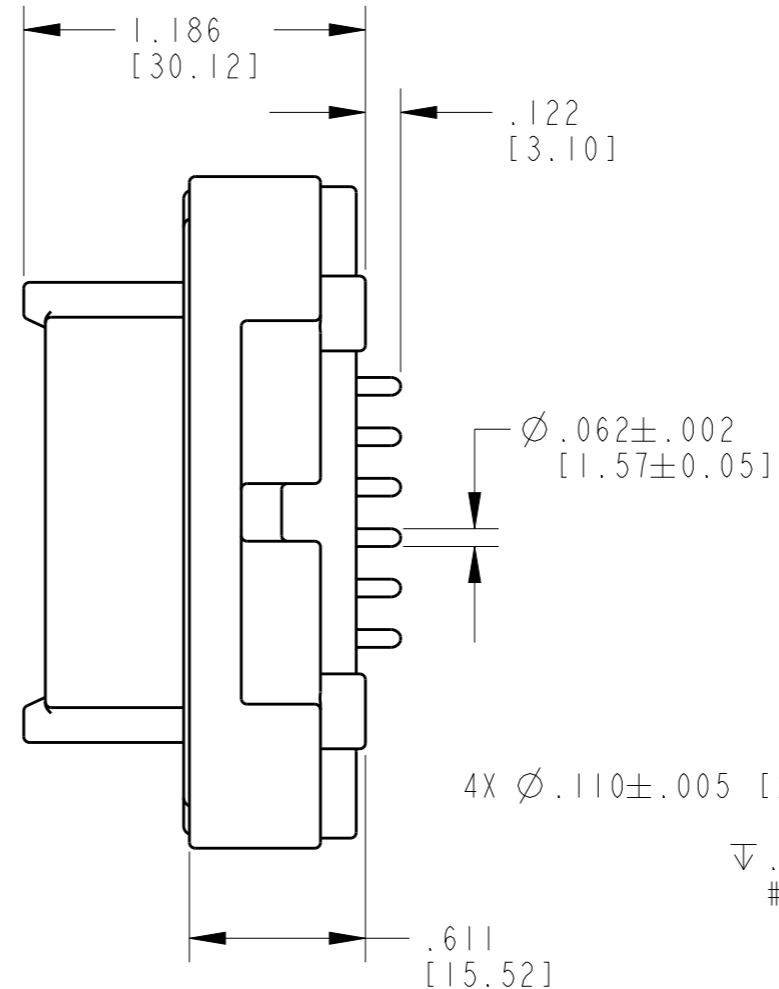
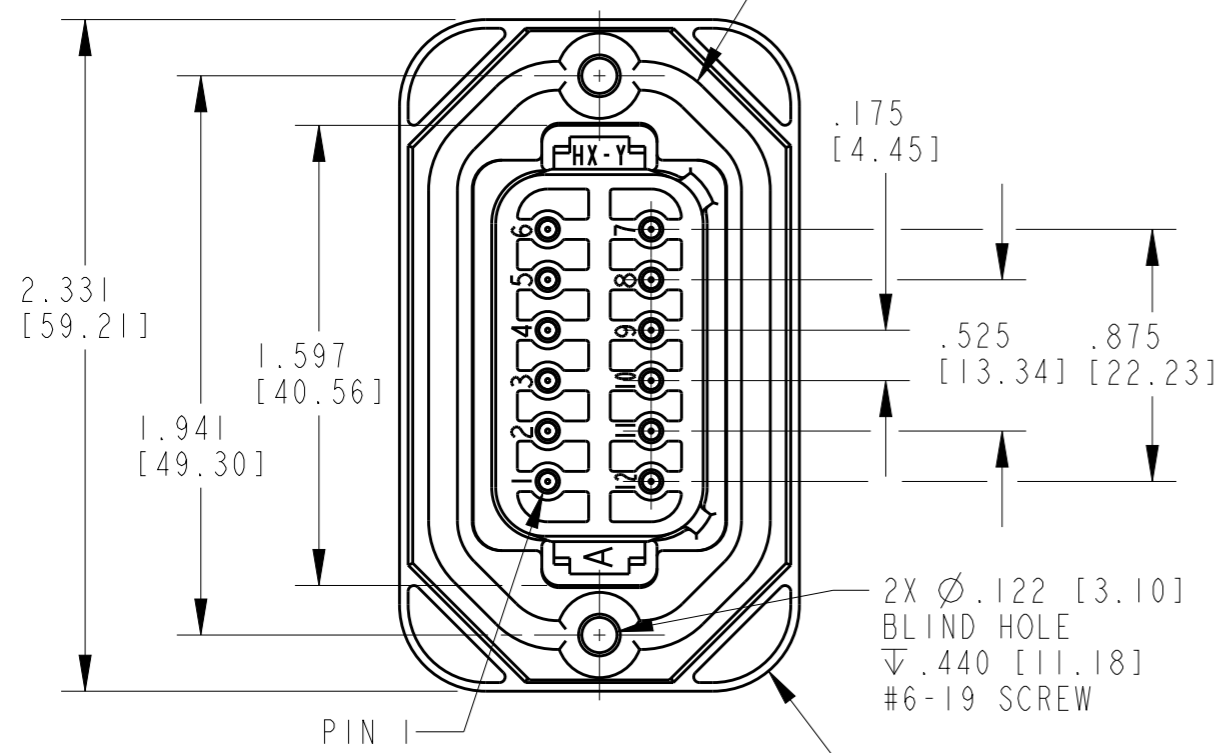
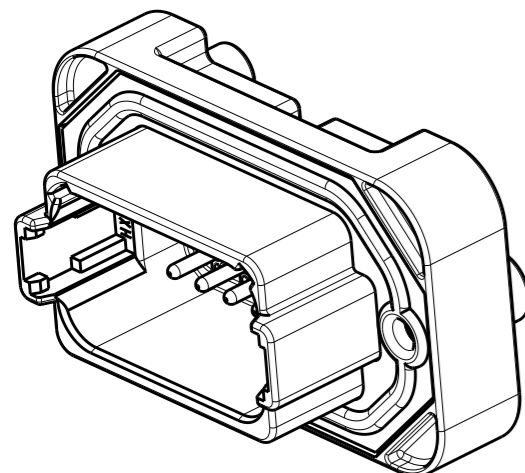

- SEE SHEET 2 FOR OTHER KEY ARRANGEMENTS.
- MOUNTING SCREW TORQUE VALUES ARE AS FOLLOWS:
 #6-19 SCREWS: 11-15 IN-LB [1.24-1.70 N-m].
 #4-20 SCREWS: 6-10 IN-LB [.68-1.13 N-M].
 VALUES VALID FOR PLASTITE 48 SCREWS ONLY.
- RECOMMENDED MOUNTING SCREWS (NOT INCLUDED): CAMCAR PLASTITE 48, SINGLE HELIX.
- THIS RECEPTACLE MATES WITH DT06-12SX-XXXX PLUG (X = A,B,C,D KEYS, XXXX = ALL MODIFICATIONS).
- CONTACT PLATING - MATING SIDE: NICKEL; PCB SIDE: TIN

TE INTERNAL PN	DEUTSCH PN
DT15-12PA	DT15-12PA
DT15-12PB	DT15-12PB
DT15-12PC	DT15-12PC
DT15-12PD	DT15-12PD

- 2 MATERIALS:
 HOUSING/PIN SPACER: PA46 GF30 (SEE SHEET 2 FOR COLORS)
 FLANGE SEAL: VMQ (RED-ORANGE)
 PIN CONTACTS: COPPER ALLOY
- 1 DIMENSION TOLERANCE: ±.025 [.64]
 PANEL CUTOUT: ±.010 [.25]
 PIN LOCATIONS: ±.005 [.13]
 MOUNTING HOLE LOCATIONS: ±.010 [.13]

THIS DRAWING IS A CONTROLLED DOCUMENT.		DWN P. BURKE 08JUN2001	 TE Connectivity		
DIMENSIONS: INCHES [mm]		CHK KEVIN MCKEE 03JUL2014			NAME RECEPTACLE HEADER 12 PIN 180 DEG DT SERIES
TOLERANCES UNLESS OTHERWISE SPECIFIED:		APVD DAVID MEYER 03JUL2014			
0 PLC ± 1 PLC ± 2 PLC ± 3 PLC ± 4 PLC ± ANGLES ±0°30'0"		PRODUCT SPEC			SIZE A3
MATERIAL		APPLICATION SPEC	CAGE CODE 4AFU8	DRAWING NO DT15-12PX	
FINISH		WEIGHT	RESTRICTED TO		
2		CUSTOMER DRAWING	SCALE 3:2	SHEET 1 OF 2	
			REV C2		

LOC		DIST		REVISIONS				
P	LTR	DESCRIPTION			DATE	DWN	APVD	
	-	SEE SHEET 1			-	-	-	

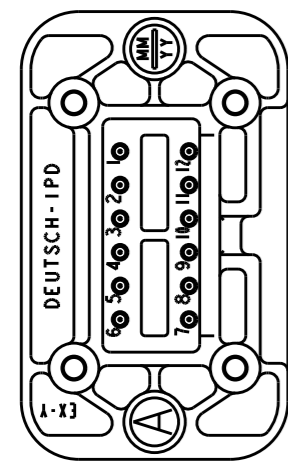
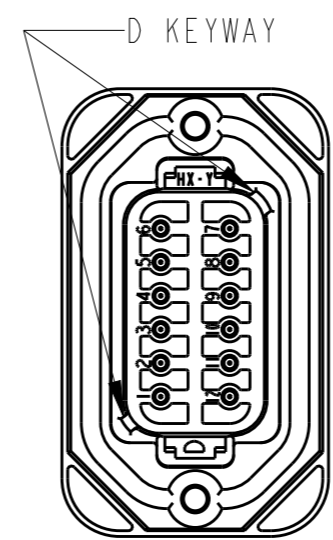
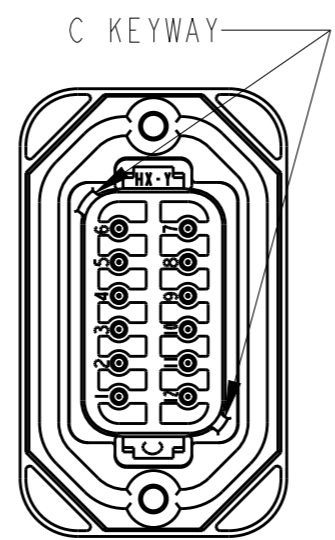
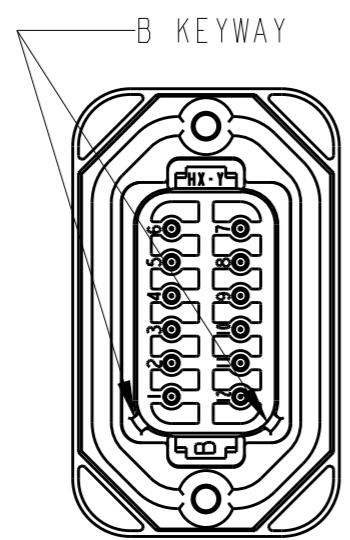
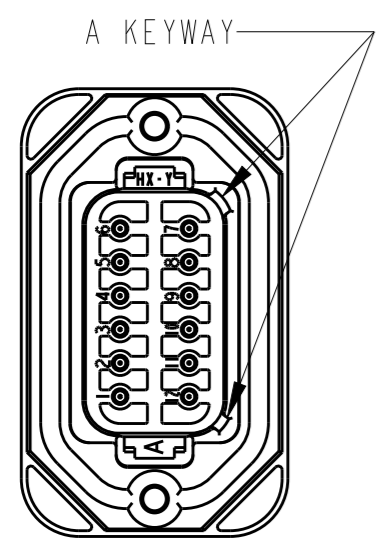

DT15-12PA
COLOR GREY

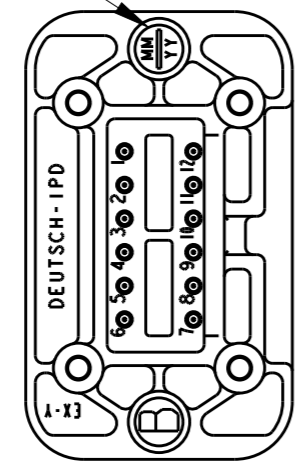

DT15-12PB
COLOR BLACK

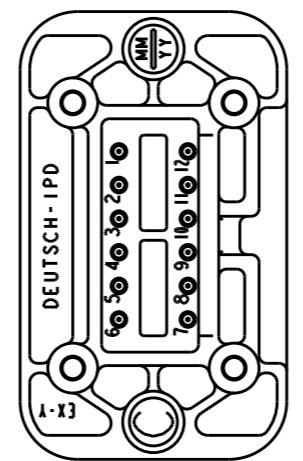

DT15-12PC
COLOR GREEN

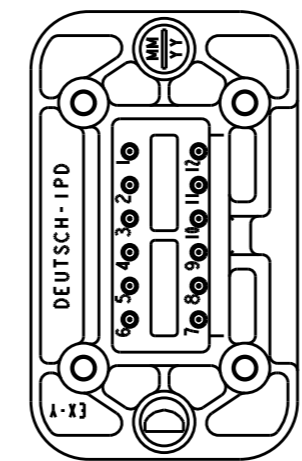

DT15-12PD
COLOR BROWN

DATE CODE

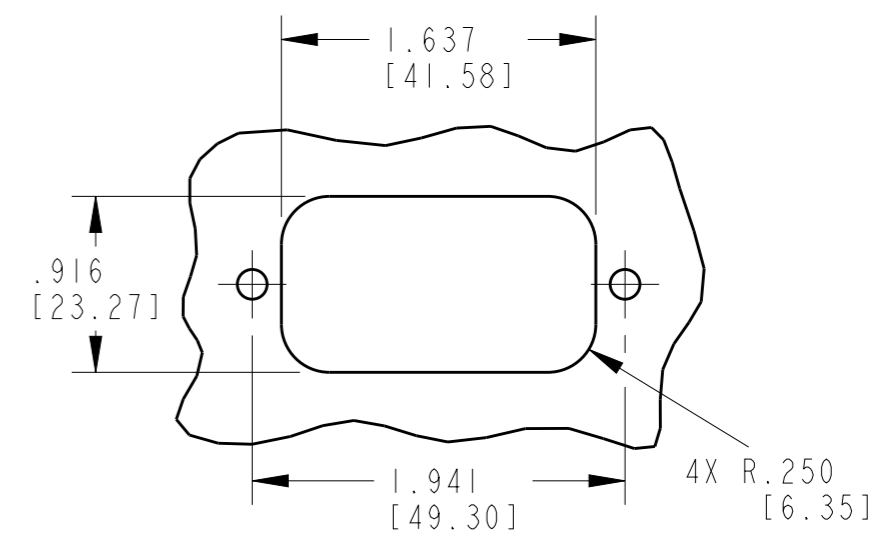
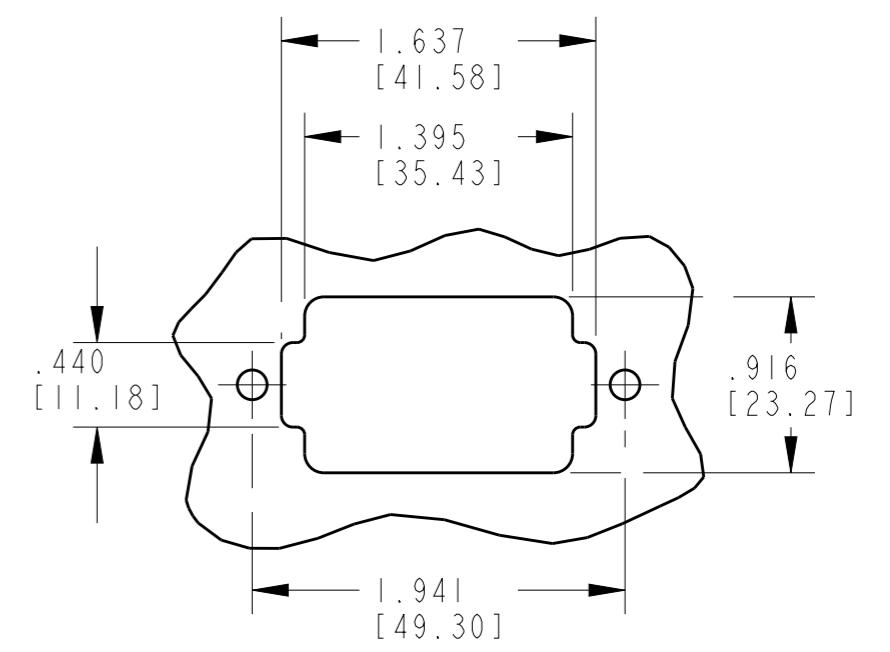

RECOMMENDED PANEL CUTOUTS

THIS DRAWING IS A CONTROLLED DOCUMENT.		DWN P. BURKE 08JUN2001	TE Connectivity	
DIMENSIONS: INCHES [mm]		CHK KEVIN MCKEE 03JUL2014		
TOLERANCES UNLESS OTHERWISE SPECIFIED:		APVD DAVID MEYER 03JUL2014	NAME RECEPTACLE HEADER 12 PIN 180 DEG DT SERIES	
0 PLC ± 1 PLC ± 2 PLC ± 3 PLC ± 4 PLC ± ANGLES ±0°30'0"		PRODUCT SPEC	RESTRICTED TO	
MATERIAL		APPLICATION SPEC	SIZE A3	CAGE CODE 4AFU8
FINISH		WEIGHT	DRAWING NO DT15-12PX	REV C2
		CUSTOMER DRAWING	SCALE 1:1	SHEET 2 OF 2