

Tous droits strictement réservés. Reproduction ou communication à des tiers interdite sous quelque forme que ce soit sans autorisation écrite du propriétaire. Propriété de c FCI. Droits de reproduction FCI.

All rights strictly reserved. Reproduction or issue to third parties in any form whatever is not permitted without written authority from the proprietor. Property of FCI. Copyright FCI.

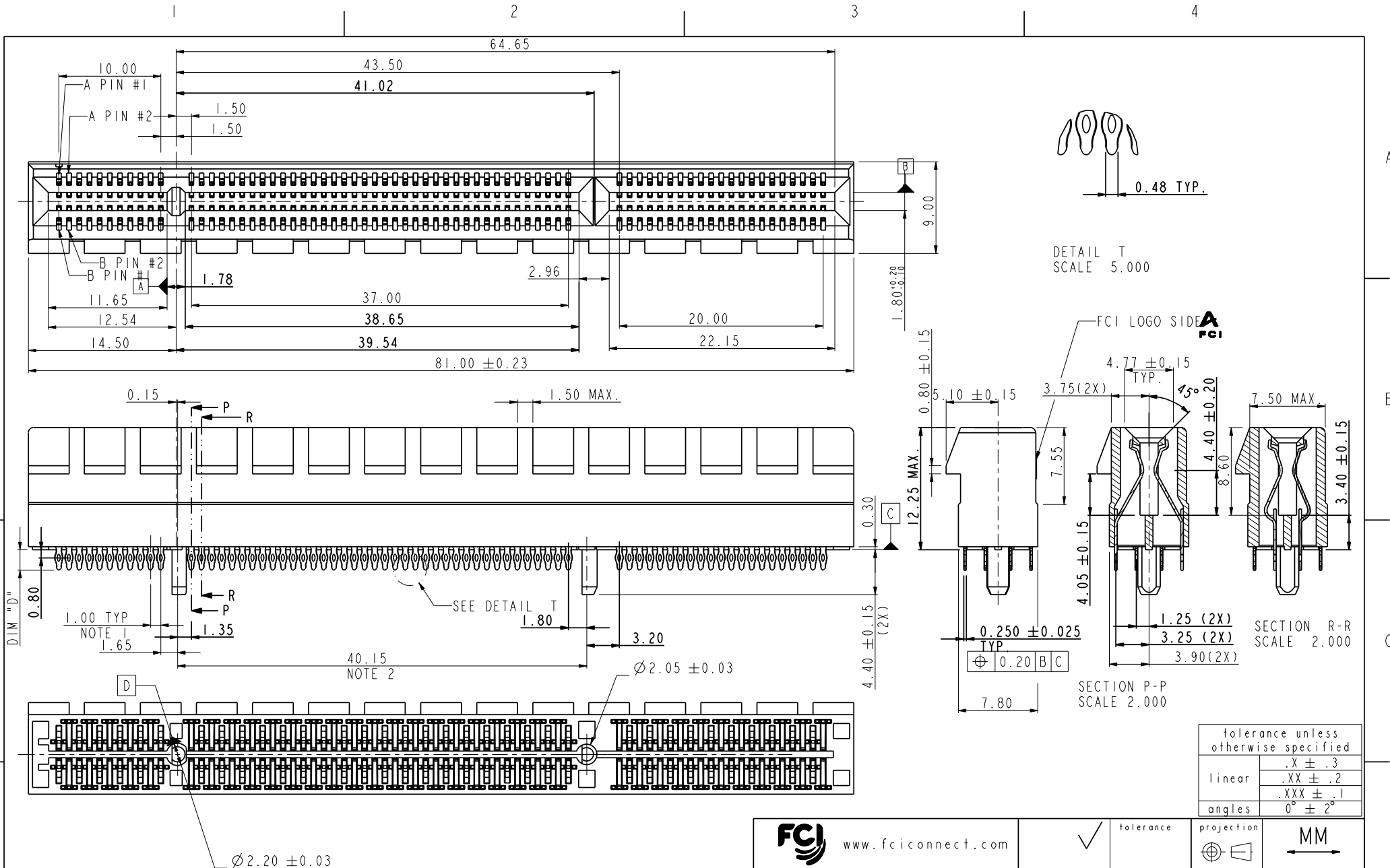

tolerance unless otherwise specified	
linear	.X ± .3
	.XX ± .2
	.XXX ± .1
angles	0° ± 2°

www.fciconnect.com		<input checked="" type="checkbox"/> tolerance	<input type="checkbox"/> projection	<input type="checkbox"/> size	<input type="checkbox"/> Scale
Dr	MAGGIE WU	04/20/05	Product family	A4	1.000
Eng	R Y LIU	04/20/05	Spec ref		
Chr	PAUL WANG	04/20/05	Material	ECN	DG06-0249
Appr	JOSEPH HSIA	04/20/05			
title PCI Express ExpressModule CARD EDGE 140P PRESS-FIT ASS'Y			dwg no 10055295	Rev. F	
catalog no			CUSTOMER DRAWING sheet 1 of 5 PDM: Rev:F STATUS:Released Printed: Mar 15, 2011		

rev	ecn no	dr	date
A	T05-0236	M W	10/18/05
B	T05-0243	M W	10/27/05
C	T05-0257	M W	11/08/05
D	T05-0287	M W	12/19/05
E	DG06-0161	P M	04/11/06
F	DG06-0249	P M	07/04/06

Tous droits strictement réservés. Reproduction ou communication a des tiers interdite sous quelque forme que ce soit sans autorisation écrite du propriétaire. Propriété de c FCI. Droits de reproduction FCI.

All rights strictly reserved. Reproduction or issue to third parties in any form whatever is not permitted without written authority from the proprietor. Property of FCI. Copyright FCI.

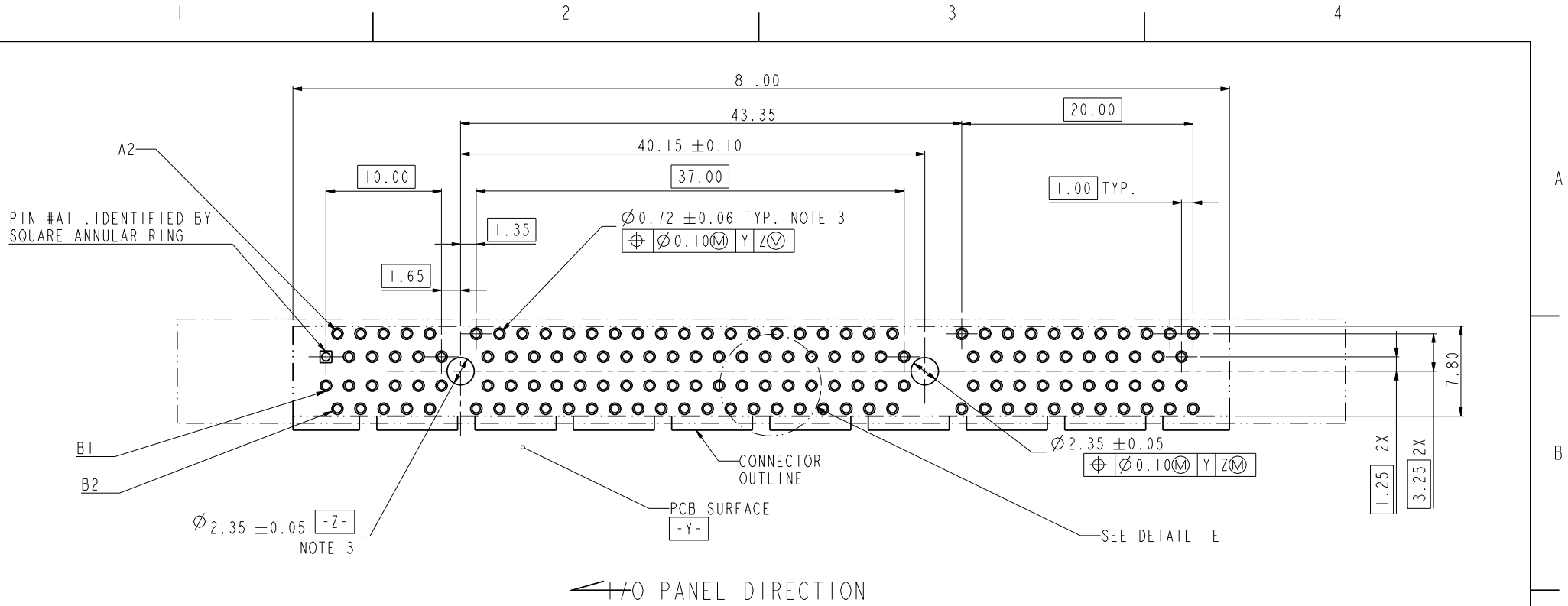

RECOMMENDED FOOTPRINT

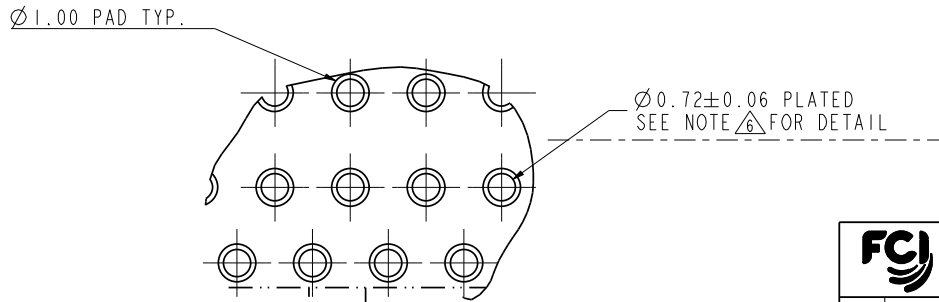

DETAIL E
SCALE 5.000

tolerance unless otherwise specified	
linear	.X ± .3 .XX ± .2 .XXX ± .1
angles	0° ± 2°

	www.fciconnect.com		✓	tolerance	projection	MM
	Dr	MAGGIE WU	04/20/05	Product family	size	A4
Eng	R Y LIU	04/20/05	Spec ref	ECN	DG06-0249	Scale
Chr	PAUL WANG	04/20/05	Material			1.000
Appr	JOSEPH HSIA	04/20/05				

title	PCI Express ExpressModule CARD EDGE 140P PRESS-FIT ASS'Y		dwg no	10055295	Rev.	F
catalog no	PDM: Rev:F		STATUS: Released		CUSTOMER DRAWING sheet 2 of 5 Printed: Mar 15, 2011	

Tous droits strictement réservés. Reproduction ou communication à des tiers interdite sous quelque forme que ce soit sans autorisation écrite du propriétaire. Propriété de c FCI. Droits de reproduction FCI.



All rights strictly reserved. Reproduction or issue to third parties in any form whatever is not permitted without written authority from the proprietor. Property of FCI. Copyright FCI.

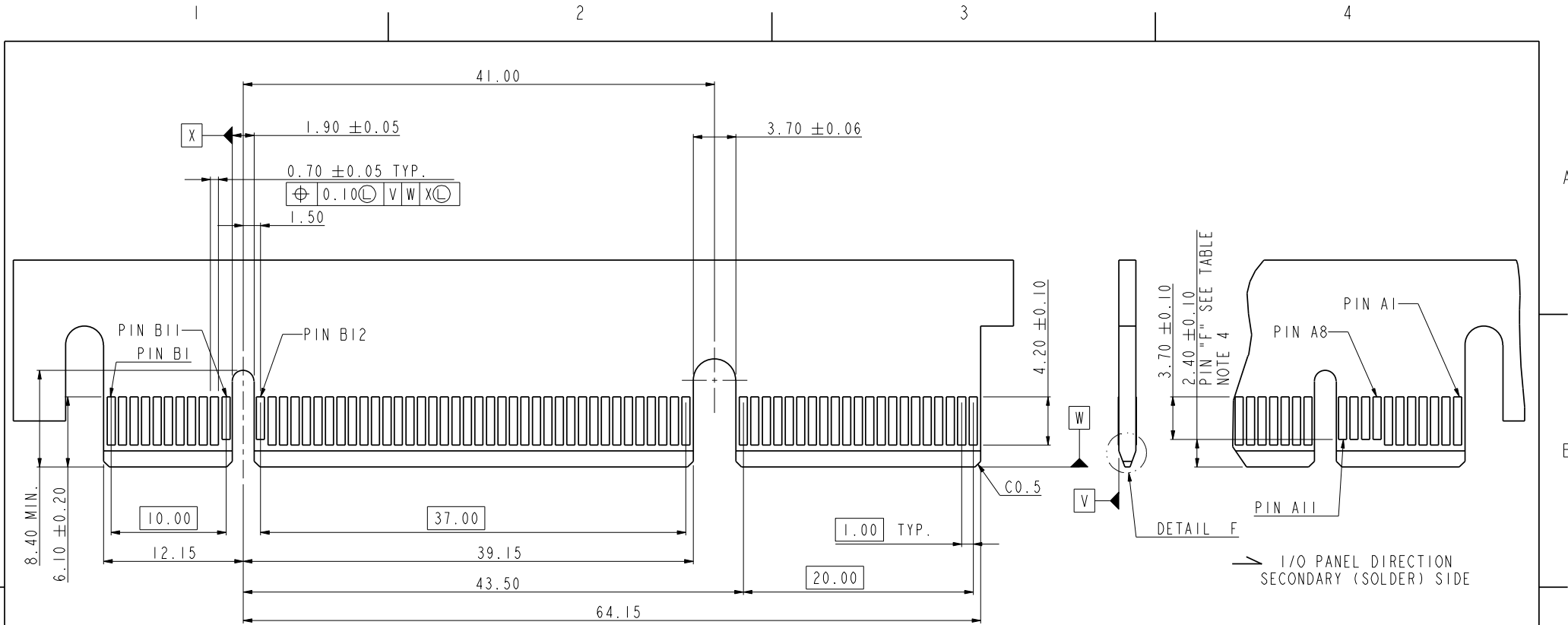

← I/O PANEL DIRECTION
PRIMARY (COMPONENT) SIDE

→ I/O PANEL DIRECTION
SECONDARY (SOLDER) SIDE

1.57 ± 0.13
ACROSS PADS
20° ± 5° NOTE 5

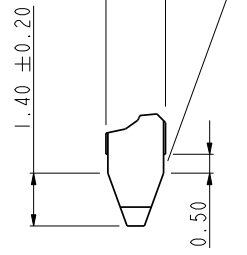

DETAIL F
SCALE 5.000

CONNECTOR LINK WIDE	#POS REF.	"F" NOTE 4
X8E	140	A8, A9, A10, A11 B11, B12

tolerance unless otherwise specified	
linear	.X ± .2 .XX ± .13 .XXX ± .05
angles	0° ± 2°

FCI www.fciconnect.com		tolerance	projection	MM
Dr	MAGGIE WU	04/20/05	Product family	size A4
Eng	R Y LIU	04/20/05	Spec ref	Scale 1.000
Chr	PAUL WANG	04/20/05	Material	ECN DG06-0249
Appr	JOSEPH HSIA	04/20/05		

title	PCI Express ExpressModule CARD EDGE 140P PRESS-FIT ASS'Y		dwg no	10055295	Rev.	F
catalog no	PDM: Rev:F		STATUS: Released		CUSTOMER DRAWING sheet 3 of 5 Printed: Mar 15, 2011	

Tous droits strictement réservés. Reproduction ou communication a des tiers interdite sous quelque forme que ce soit sans autorisation écrite du propriétaire. Propriété de c FCI. Droits de reproduction FCI.

All rights strictly reserved. Reproduction or issue to third parties in any form whatever is not permitted without written authority from the proprietor. Property of FCI. Copyright FCI.

NOTES:

1. MATERIAL:
HOUSING: HIGH TEMPERATURE NYLON, GLASS FILLED UL94V-0 RATED. SUITABLE FOR REFLOW SOLDERING.
TERMINAL: COPPER ALLOY
PLATING: 50u" NICKEL UNDERPLATE ALL OVER
CONTACT AREA PLATING - SEE PRODUCT NUMBER CODE
SOLDER TAIL: TIN - 100u" MIN. OVER 50u" NICKEL OR TIN/LEAD 100u" MIN. SEE PRODUCT NUMBER CODE
2. PRODUCT SPECIFICATION: GS-12-319
3. THE HORIZONTAL AXIS FOR THE HOLE PATTERN IS ESTABLISHED BY A LINE THROUGH THE CENTER OF THE TWO Ø2.35 HOLES.
THE VERTICAL AXIS IS 90° TO THE HORIZONTAL AXIS, THROUGH THE CENTER OF DATUM Z.
4. NO TIE BAR PERMITTED FROM CARD EDGE TO LEADING EDGE OF PAD FOR PINS A1 AND PIN NUMBERS "F".
5. CHAMFER EDGES MUST BE FREE OF CUTTING BURRS.
6. ALL PLATED THRU HOLES SHOULD BE 0.76-0.83 mm DIA DRILLED AND 0.025mm ~ 0.05mm. ELECTRO-DEPOSITED COPPER THK ON THROUGH HOLE WALL.
7. RoHS COMPATIBLE PRODUCT SPECIFICATIONS
a-PLATING:
- "LF" MEANS THE PRODUCT IS LEAD-FREE, 2um MINIMUM MATTE TIN OVER 1.27um MINIMUM NICKEL UNDERPLATE.
b-MANUFACTURING PROCESS COMPATIBILITY
- THE HOUSING WILL WITHSTAND EXPOSURE TO 260°C±5°C SOLDER BATH TEMPERATURE FOR 10 SECONDS IN A REFLOW SOLDER APPLICATION WITH A 2.36mm AND 4.19mm MIN THICK CIRCUIT BOARD.

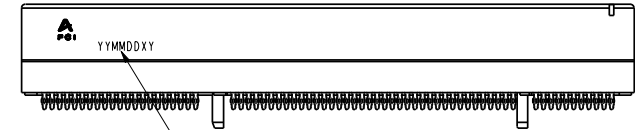

Date code:
"YY" means year number
"MM" means month number
"DD" means day number
"X" means manufacture location
"D" means made in Dongguan site
"Y" means shift number
If date code is 060626D1, it means this part is made by shift 1 in 2006/06/26 and manufactured in Dongguan site
Date code should be laser mark

PRODUCT NUMBER CODE

10055295 - X X X X X X X X

HOUSING COLOR OPTIONS
1-BLACK

PEGS OPTIONS
0-PLASTIC PEGS

TERMINAL PLATING OPTIONS
0-50u" Ni UNDERPLATE
30u" Au CONTACT AREA
100u" TIN TAIL AREA -----COMPATIBLE RoHS

3-50u" Ni UNDERPLATE
30u" Au CONTACT AREA
100u" TIN/LEAD TAIL AREA -----RoHS COMPLIANT EXCEPT Pb

LEAD FREE OPTION
"LF" FOR TERMINAL PLATING OPTION 0
LEAVE BLANK FOR TERMINAL PLATING OPTION 3

PACKAGING OPTIONS
T-TRAY PACKAGING

RESERVE
0

TAIL LENGTH OPTIONS

	DIM "D"	SUGGESTED PCB THICKNESS
0	2.00±0.20	2.36
1	3.25±0.20	4.19

tolerance unless otherwise specified	
linear	.X ± .3 .XX ± .2 .XXX ± .1
angles	0° ± 2°

FCI www.fciconnect.com		✓	tolerance	projection	MM
Dr	MAGGIE WU	04/20/05	Product family	size	A4
Eng	R Y LIU	04/20/05	Spec ref	Scale	1.000
Chr	PAUL WANG	04/20/05	Material	ECN	DG06-0249
Appr	JOSEPH HSIA	04/20/05			
title			PCI Express ExpressModule CARD EDGE 140P PRESS-FIT ASS'Y		Rev.
catalog no			10055295		F
PDM: Rev:F			STATUS: Released		Printed: Mar 15, 2011

Tous droits strictement reserves. Reproduction ou communication a des tiers interdite sous quelque forme que ce soit sans autorisation écrite du propriétaire. Propriete de c FCI. Droits de reproduction FCI.



All rights strictly reserved. Reproduction or issue to third parties in any form whatever is not permitted without written authority from the proprietor. Property of FCI. Copyright FCI.

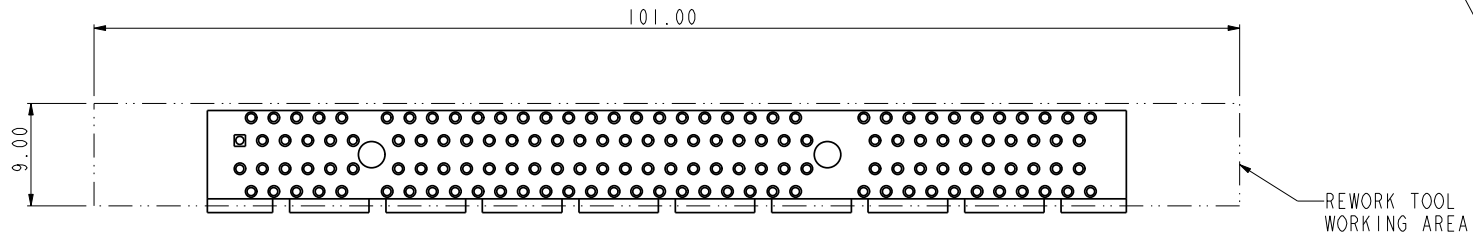

140P
SCALE 1.500

		www.fciconnect.com		✓	tolerance	projection	MM
Dr	MAGGIE WU	04/20/05	Product family		size	A4	Scale
Eng	R Y LIU	04/20/05	Spec ref				1.000
Chr	PAUL WANG	04/20/05	Material		ECN	DG06-0249	
Appr	JOSEPH HSIA	04/20/05					
title			PCI Express ExpressModule CARD EDGE 140P PRESS FIT ASS'Y		dwg no	10055295	
catalog no			PDM: Rev:F		STATUS: Released	CUSTOMER	sheet 5 of 5
					Printed: Mar 15, 2011		
					Rev. F		