

Octal squib driver ASIC for safety application

Features

- 8 deployment drivers with SPI selectable firing current and times
- Capability to deploy the squib with 1.2 A (min)/2 ms, 1.75 A (min)/1.0 ms and 1.75 A (min)/0.65 ms between VRES of 7 V to 37 V
- Capability to deploy the squib with 1.5 A (min)/2 ms between VRES of 7 V to 25 V
- Firing capability to deploy all channels simultaneously
- Independently controlled high-side and low-side MOS for diagnosis
- Analog output available for resistance measurement
- Squib short to ground, short to battery and MOS diagnostic available on SPI register
- Capability to deploy the squib the low side MOS is shorted to ground
- 4 fire enable inputs
- 5.5 MHz SPI interface
- Low voltage internal reset
- 2 kV ESD capability on all pins
- Package: LQFP64

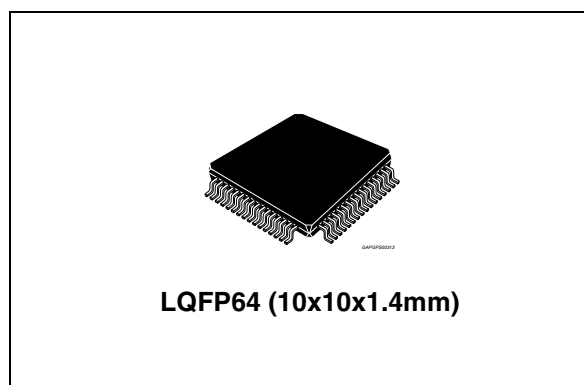

- Technology: ST proprietary BCD5 (0.65 μ m)
- RoHS compliant

Description

The L9659 is intended to deploy up to 8 squibs. Squib drivers are sized to deploy 1.2 A minimum for 2 ms, 1.75 A minimum for 1 ms and 1.75 A minimum for 0.65 ms during load dump along with 1.5 A minimum for 2 ms for VRES voltages less than 25 V.

Full diagnostic capabilities of the squib interface are provided.

Table 1. Device summary

| Order code | Amb. temp range, °C | Package | Packing |
|------------|---------------------|---------|---------------|
| L9659 | -40 to +95 | LQFP64 | Tray |
| L9659TR | -40 to +95 | LQFP64 | Tape and reel |

Contents

- 1 Block diagram and pin description 5**
 - 1.1 Block diagram 5
 - 1.2 Pin description 5
 - 1.3 Application schematic 8

- 2 Electrical specifications 9**
 - 2.1 Absolute maximum ratings 9
 - 2.2 Absolute maximum degraded operating ratings 10
 - 2.3 Operating ratings 10
 - 2.4 Electrical characteristics 11
 - 2.4.1 General 11
 - 2.4.2 Electrical characteristics - Squib deployment drivers and diagnostics .. 12
 - 2.4.3 SPI timing 17

- 3 Functional description 19**
 - 3.1 Overview 19
 - 3.2 General functions 19
 - 3.2.1 Power on reset (POR) 19
 - 3.2.2 RESETB 19
 - 3.2.3 Reference resistor 20
 - 3.2.4 Loss of ground 20
 - 3.2.5 VRESx capacitance 20
 - 3.2.6 Supply voltages 20
 - 3.2.7 Ground connections 20
 - 3.3 Serial peripheral interface (SPI) 21
 - 3.3.1 SPI pin descriptions 21
 - 3.4 Squib drivers 22
 - 3.4.1 Firing 22
 - 3.4.2 Firing current measurement 25
 - 3.4.3 Fire enable (FEN) function description 26
 - 3.4.4 Squib diagnostics 27
 - 3.4.5 SPI register definition for squib functions 31

- 4 Package information 49**

- 5 Revision history 50**

List of tables

| | | |
|-----------|--|----|
| Table 1. | Device summary | 1 |
| Table 2. | Pin description | 5 |
| Table 3. | Absolute maximum ratings | 9 |
| Table 4. | Absolute maximum degraded operating ratings | 10 |
| Table 5. | Operating ratings | 10 |
| Table 6. | General - DC electrical characteristics | 11 |
| Table 7. | Squib deployment drivers and diagnostics - DC electrical characteristics | 12 |
| Table 8. | SPI timing - DC electrical characteristics | 17 |
| Table 9. | Features that are accessed/controlled for the SPI | 21 |
| Table 10. | SPI MOSI/MISO response | 25 |
| Table 11. | How faults shall be interpreted | 28 |
| Table 12. | Diagnostic Mode HSS selection | 30 |
| Table 13. | Diagnostic mode 3 VRESx selection | 30 |
| Table 14. | MISO responses to various events | 31 |
| Table 15. | Command description summary | 32 |
| Table 16. | Configuration mode 1 | 33 |
| Table 17. | Configuration mode 2 | 34 |
| Table 18. | Deployment mode 1 bit definition | 35 |
| Table 19. | Deployment mode 2 bit definition | 36 |
| Table 20. | Diagnostic selection | 40 |
| Table 21. | Diagnostic mode LS FET selection | 40 |
| Table 22. | Diagnostic mode HS FET selection | 41 |
| Table 23. | Diagnostic mode HSS selection | 41 |
| Table 24. | Diagnostic mode VRESx selection | 41 |
| Table 25. | Channel selection | 42 |
| Table 26. | MOSI diagnostic mode 1 bit definition | 43 |
| Table 27. | DEPLOY_STATUSx flag and the DEPLOY_SUCCESSx flag conditions | 44 |
| Table 28. | MOSI monitor mode 2 Bit definition | 45 |
| Table 29. | Current measurement channel selections | 45 |
| Table 30. | MOSI monitor mode 3 bit definition | 46 |
| Table 31. | MOSI monitor mode 4 bit definition | 48 |
| Table 32. | Document revision history | 50 |

List of figures

| | | |
|------------|--|----|
| Figure 1. | Block diagram | 5 |
| Figure 2. | Application schematic | 8 |
| Figure 3. | MOS settling time and turn-on time 2 | 16 |
| Figure 4. | SPI timing diagram | 18 |
| Figure 5. | MISO loading for disable time measurement | 18 |
| Figure 6. | POR timing | 19 |
| Figure 7. | Deployment drivers diagram | 23 |
| Figure 8. | Driver activation timing diagram | 24 |
| Figure 9. | Squib diagnostics block diagram | 27 |
| Figure 10. | LQFP64 mechanical data and package dimensions. | 49 |

1 Block diagram and pin description

1.1 Block diagram

Figure 1. Block diagram

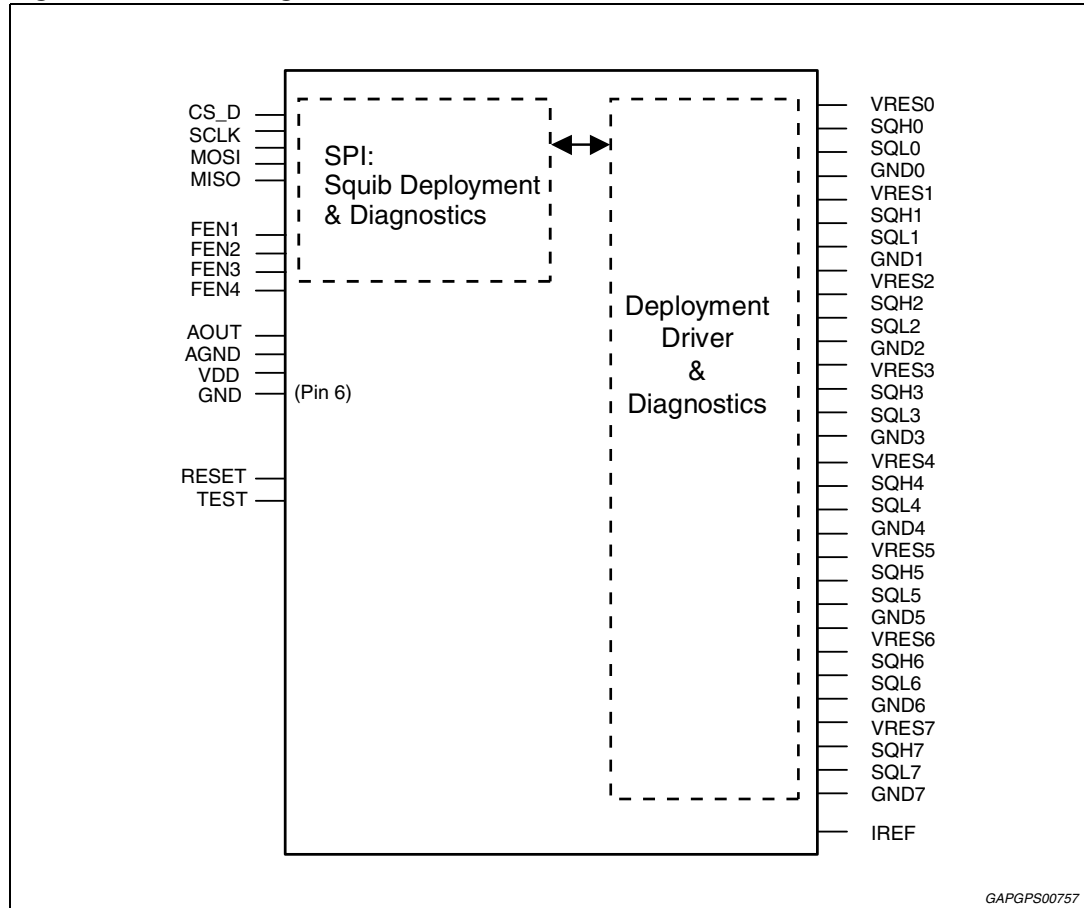

1.2 Pin description

Table 2. Pin description

| Pin # | Pin name | Description | I/O type | Reset state |
|-------|----------|----------------------------------|----------|-------------|
| 1 | MISO | SPI data out | Output | Hi-Z |
| 2 | NC | No connect | - | - |
| 3 | FEN1 | Fire enable for channels 0 and 1 | Input | Pulldown |
| 4 | FEN2 | Fire enable for channels 2 and 3 | Input | Pulldown |
| 5 | RESETB | Reset pin | Input | Pullup |
| 6 | GND | Ground (analog & digital) | - | - |
| 7 | VDD | VDD supply voltage | Input | - |

Table 2. Pin description (continued)

| Pin # | Pin name | Description | I/O type | Reset state |
|-------|----------|--|----------|-------------|
| 8 | FEN3 | Fire enable for channels 4 and 5 | Input | Pulldown |
| 9 | FEN4 | Fire enable for channels 6 and 7 | Input | Pulldown |
| 10 | NC | No connect | - | - |
| 11 | NC | No connect | - | - |
| 12 | CS_D | SPI chip select for deployment driver | Input | Pullup |
| 13 | MOSI | SPI data in | Input | Hi-Z |
| 14 | NC | No connect | - | - |
| 15 | NC | No connect | - | - |
| 16 | SCLK | SPI clock | Input | Hi-Z |
| 17 | GND4 | Power ground for loop channel 4 | - | - |
| 18 | SQL4 | Low side driver output for channel 4 | Output | Pulldown |
| 19 | SQH4 | High side driver output for channel 4 | Output | Hi-Z |
| 20 | VRES4 | Reserve voltage for loop channel 4 | Input | - |
| 21 | VRES5 | Reserve voltage for loop channel 5 | Input | - |
| 22 | SQH5 | High side driver output for channel 5 | Output | Hi-Z |
| 23 | SQL5 | Low side driver output for channel 5 | Output | Pulldown |
| 24 | GND5 | Power ground for loop channel 5 | - | - |
| 25 | GND6 | Power ground for loop channel 6 | - | - |
| 26 | SQL6 | Low side driver output for channel 6 | Output | Pulldown |
| 27 | SQH6 | High side driver output for channel 6 | Output | Hi-Z |
| 28 | VRES6 | Reserve voltage for loop channel 6 | Input | - |
| 29 | VRES7 | Reserve voltage for loop channel 7 | Input | - |
| 30 | SQH7 | High side driver output for channel 7 | Output | Hi-Z |
| 31 | SQL7 | Low side driver output for channel 7 | Output | Pulldown |
| 32 | GND7 | Power ground for loop channel 7 | - | - |
| 33 | TEST | Test pin | Input | Pulldown |
| 34 | VSDIAG | Supply for deployment driver diagnostics | Input | - |
| 35 | NC | No connect | - | - |
| 36 | Reserved | Factory testmode output | - | - |
| 37 | Reserved | Factory testmode output | - | - |
| 38 | NC | No connect | - | - |
| 39 | NC | No connect | - | - |
| 40 | NC | No connect | - | - |
| 41 | NC | No connect | - | - |
| 42 | NC | No connect | - | - |

Table 2. Pin description (continued)

| Pin # | Pin name | Description | I/O type | Reset state |
|-------|----------|---------------------------------------|----------|-------------|
| 43 | NC | No connect | - | - |
| 44 | NC | No connect | - | - |
| 45 | NC | No connect | - | - |
| 46 | IREF | External current reference resistor | Output | - |
| 47 | AGND | Ground reference for AOUT | - | - |
| 48 | AOUT | Analog output for loop diagnostics | Output | Hi-Z |
| 49 | GND3 | Power ground for loop channel 3 | - | - |
| 50 | SQL3 | Low side driver output for channel 3 | Output | Pulldown |
| 51 | SQH3 | High side driver output for channel 3 | Output | Hi-Z |
| 52 | VRES3 | Reserve voltage for loop channel 3 | Input | - |
| 53 | VRES2 | Reserve voltage for loop channel 2 | Input | - |
| 54 | SQH2 | High side driver output for channel 2 | Output | Hi-Z |
| 55 | SQL2 | Low side driver output for channel 2 | Output | Pulldown |
| 56 | GND2 | Power ground for loop channel 2 | - | - |
| 57 | GND1 | Power ground for loop channel 1 | - | - |
| 58 | SQL1 | Low side driver output for channel 1 | Output | Pulldown |
| 59 | SQH1 | High side driver output for channel 1 | Output | Hi-Z |
| 60 | VRES1 | Reserve voltage for loop channel 1 | Input | - |
| 61 | VRES0 | Reserve voltage for loop channel 0 | Input | - |
| 62 | SQH0 | High side driver output for channel 0 | Output | Hi-Z |
| 63 | SQL0 | Low side driver output for channel 0 | Output | Pulldown |
| 64 | GND0 | Power ground for loop channel 0 | - | - |

1.3 Application schematic

Figure 2. Application schematic

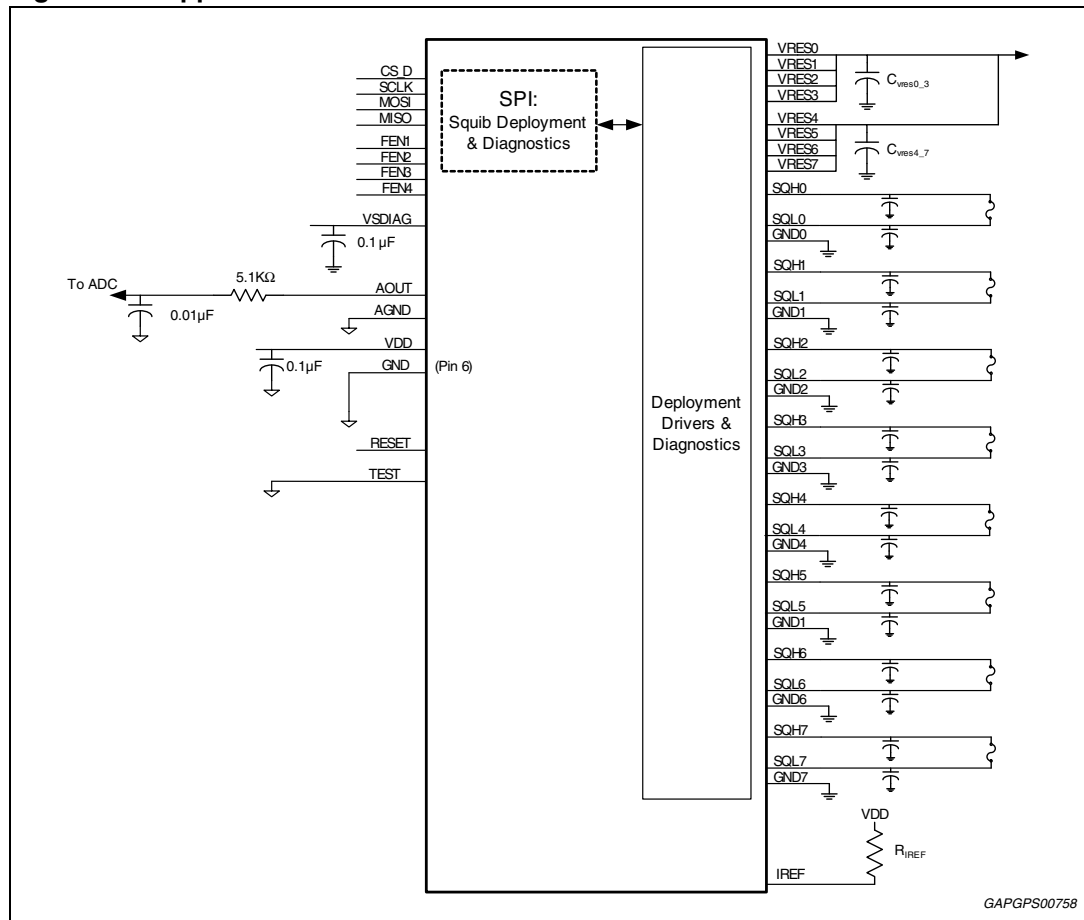

2 Electrical specifications

2.1 Absolute maximum ratings

The following maximum ratings are continuous absolute ratings; exceeding any one of these values may cause permanent damage to the integrated circuit.

Table 3. Absolute maximum ratings

| Symbol | Parameter | Value | Unit |
|--|---|--------------|------|
| $V_{DD}^{(1)}$ | Supply voltage | - 0.3 to 5.5 | V |
| V_{SDIAG} | Supply voltage for squib diagnostics | - 0.3 to 40 | V |
| $VRESx$ | VRES voltage (VRES0, VRES1, VRES2, VRES3, VRES4, VRES5, VRES6, VRES7) | - 0.3 to 40 | V |
| $SQHx$ | Squib high side drivers (SQH0, SQH1, SQH2, SQH3, SQH4, SQH5, SQH6, SQH7) | - 0.6 to 40 | V |
| $SQLx$ | Squib low side drivers (SQL0, SQL1, SQL2, SQL3, SQL4, SQL5, SQL6, SQL7) | - 0.3 to 40 | V |
| TEST | Test pin | -0.3 to 40 | V |
| V_I | Discrete input voltage (RESETB, CS_D, SCLK, MOSI, FEN1, FEN2, FEN3, FEN4, IREF) | - 0.3 to 5.5 | V |
| V_O | Discrete output voltage (MISO, AOUT) | - 0.3 to 5.5 | V |
| AGND | Analog output reference | -0.3 to 5.5 | V |
| $GNDx$ | Ground (GND0, GND1, GND2, GND3, GND4, GND5, GND6, GND7) | -0.3 to 5.5 | V |
| $T_j^{(2)}$ | Maximum steady-state junction temperature | 150 | °C |
| T_{amb} | Ambient temperature | -40 to 95 | °C |
| T_{stg} | Storage temperature | -65 to 150 | °C |
| $R_{th j amb}$ | Thermal resistance junction to ambient (on FR-4 board) | 46 | °C/W |
| The following maximum ratings are up to 48 hours; exceeding any one of these values for longer than a total time of 48 hours may cause permanent damage to the integrated circuit. | | | |
| V_{DD} | Supply voltage | - 0.3 to 6.0 | V |
| V_I | Discrete input voltage (RESETB, CS_D, SCLK, MOSI, FEN1, FEN2, FEN3, FEN4, IREF) | - 0.3 to 6.0 | V |
| V_O | Discrete output voltage (MISO, AOUT) | - 0.3 to 6.0 | V |
| AGND | Analog output reference | -0.3 to 6.0 | V |
| $GNDx$ | Ground (GND0, GND1, GND2, GND3, GND4, GND5, GND6, GND7) | -0.3 to 6.0 | V |
| $T_j^{(2)}$ | Maximum steady-state junction temperature | 150 | °C |
| T_{amb} | Ambient temperature | -40 to 95 | °C |
| T_{stg} | Storage temperature | -65 to 150 | °C |
| $R_{th j amb}$ | Thermal resistance junction to ambient (on FR-4 board) | 46 | °C/W |

1. Exceeding a V_{DD} of 5.1V during a deployment may cause damage
2. To allow for deployment the maximum steady state junction temperature cannot exceed 130°C. Under the operating ratings defined in section 2.3 the steady state junction temperature will not exceed 130°C.

2.2 Absolute maximum degraded operating ratings

Under the following deviations to the ratings indicated in [Section 2.3](#) the L9659 performance will be degraded and not meet the electrical characteristics outlined in [Section 2.4](#). At minimum the SPI and diagnostics will function but not meet specified electrical parameters.

Table 4. Absolute maximum degraded operating ratings

| Symbol | Parameter | Value | Unit |
|-------------|---|-----------------------------|------|
| V_{DD} | Supply voltage | 4.5 to 5.5 | V |
| V_{SDIAG} | Supply voltage for squib diagnostics | 7 to 40 | V |
| V_{RES} | VRES voltage (VRES0, VRES1, VRES2, VRES3, VRES4, VRES5, VRES6, VRES7) | 7 to 40 | V |
| V_I | Discrete input voltage (RESETB, DEPEND, CS_D, SCLK, MOSI, FEN1, FEN2, FEN3, FEN4, IREF) | - 0.3 to ($V_{DD} + 0.3$) | V |
| V_O | Discrete output voltage (MISO, AOUT) | -0.3 to ($V_{DD} + 0.3$) | V |
| T_j | Junction temperature | -40 to 150 | °C |

Note: The above is provided for informational purposes only and will result in degraded operation. Under the above conditions the SPI will be functional as well as diagnostics, though the electrical performance may not conform to the parameters outlined in [Section 2.4](#). Firing requirements as indicated in [Section 2.4](#) may not be met with the conditions above.

2.3 Operating ratings

Table 5. Operating ratings

| Symbol | Parameter | Value | Unit |
|----------------|---|-----------------------------|------|
| V_{DD} | Supply voltage | 4.9 to 5.1 | V |
| V_{SDIAG} | Supply voltage for squib diagnostics | 7 to 37 | V |
| V_{RESx} | VRES voltage (VRES0, VRES1, VRES2, VRES3, VRES4, VRES5, VRES6, VRES7) | 7 to 37 | V |
| V_I | Discrete input voltage (RESETB, CS_D, SCLK, MOSI, FEN1, FEN2, FEN3, FEN4, IREF) | - 0.3 to ($V_{DD} + 0.3$) | V |
| V_O | Discrete output voltage (MISO, AOUT) | -0.3 to ($V_{DD} + 0.3$) | V |
| T_{amb} | Ambient temperature | -40 to 95 | °C |
| $R_{Th j-amb}$ | Thermal resistance junction to ambient (on FR-4 board) | 46 | °C/W |

Comments:

VSDIAG supply will provide power for squib resistance and HSS diagnostics

VDD will be used for all internal functions as well as short to battery/ground and high squib resistance diagnostics.

2.4 Electrical characteristics

2.4.1 General

$4.9\text{ V} \leq V_{DD} \leq 5.1\text{ V}$; $7\text{ V} \leq V_{RESX} \leq 37\text{ V}$; $7\text{ V} \leq V_{SDIAG} \leq 37\text{ V}$; FEN1 = FEN2 = FEN3 = FEN4 = V_{DD} ; $R_{REF} = 10\text{ k}\Omega$, $\pm 1\%$, 100 PPM; $-40\text{ }^\circ\text{C} \leq T_A \leq +95\text{ }^\circ\text{C}$; unless other specified.

Table 6. General - DC electrical characteristics

| Symbol | Parameter | Test condition | Min. | Typ. | Max. | Unit |
|------------------|---|--|------|------|------------------|---------------|
| Osc | Internal oscillator frequency | Tested with 10K , 1%, 100ppm Iref resistor | 4.75 | - | 5.25 | MHz |
| V_{RST1} | Internal voltage reset VDD after de-glitch time (tpor) See Figure 7 | VDD level for L9659 to report reset condition -deployment drivers are disabled | 4.0 | - | 4.5 | V |
| V_{RST2} | Internal voltage reset VDD with no de-glitch time See | Guaranteed by design | 2.1 | - | 3.0 | |
| t_{POR} | POR De-glitch timer | Timer for VRST1 | 5 | - | 25 | μs |
| I_{DD} | Input current VDD | No squib diagnostics. No deployment. | - | - | 15 | mA |
| | | Resistance measurement diagnostics with no fault condition present. | - | - | 17 | |
| | | Short to -0.3V on SQL; VRCM active | - | - | 35 | |
| | | During deployment | - | - | 15 | |
| R_{IREF_H} | Resistance threshold IREF | - | - | 60.0 | $\text{k}\Omega$ | |
| R_{IREF_L} | | - | 2.0 | - | $\text{k}\Omega$ | |
| V_{IH_RESETB} | Input voltage threshold RESETB | - | - | 2.0 | V | |
| V_{IL_RESETB} | | - | 0.8 | - | V | |
| V_{HYS_RST} | | - | 100 | - | 300 | mV |
| V_{IH_TEST} | Input voltage threshold TEST | Guaranteed by design | - | 3.2 | - | V |
| I_{TESTPD} | Input pull-down current TEST | | 1.0 | - | 2.5 | mA |
| I_{AOUT_SHRT} | AOUT pin current limit | AOUT short to ground during squib resistance diagnostics | - | - | 20 | mA |
| $I_{RESETPU}$ | Input pull-up current RESETB | RESETB = V_{IH} to GND | -10 | - | -50 | μA |
| I_{RESx} | Quiescent current for VRESx during HSS test | Current per pin during HSS test excluding selected channel | - | - | 10 | μA |
| V_{IH} | Input voltage threshold (MOSI, SCLK, CS_D) | Input Logic = 1 | - | - | 2.0 | V |
| V_{IL} | | Input Logic = 0 | 0.8 | - | - | V |
| V_{HYST} | Input hysteresis (MOSI, SCLK, CS_D) | | 100 | - | 300 | mV |
| I_{LKGD} | Input leakage current MOSI, SCLK | $V_{IN} = V_{DD}$ | - | - | 1 | μA |
| | | $V_{IN} = 0$ to V_{IH} | -1 | - | - | μA |

Table 6. General - DC electrical characteristics (continued)

| Symbol | Parameter | Test condition | Min. | Typ. | Max. | Unit |
|--------------------|----------------------------|--|----------------------|------|------|------|
| I _{PU_CS} | Input pull-up current CS_D | V _{IN} = V _{IH} to GND | -10 | - | -50 | μA |
| V _{OH} | Output voltage MISO | I _{OH} = -800μA | V _{DD} -0.8 | - | - | V |
| V _{OL} | | I _{OL} = 1.6mA | - | - | 0.4 | V |
| I _{HI_Z} | Tri-state current MISO | MISO = V _{DD} | - | - | 1 | μA |
| | | MISO = 0V | -1 | - | - | μA |

2.4.2 Electrical characteristics - Squib deployment drivers and diagnostics

4.9 V ≤ V_{DD} ≤ 5.1 V; 7 V ≤ V_{RESX} ≤ 37 V; 7 V ≤ V_{S_{DIAG}} ≤ 37 V; FEN1 = FEN2 = FEN3 = FEN4 = V_{DD}; R_{REF} = 10 kΩ, ±1%, 100 PPM; -40 °C ≤ T_A ≤ +95 °C; C_{VRES0_1} ≥ 68nF; C_{VRES2_3} ≥ 68nF; C_{VRES4_5} ≥ 68nF; C_{VRES6_7} ≥ 68nF; unless other specified.

Table 7. Squib deployment drivers and diagnostics - DC electrical characteristics

| Symbol | Parameter | Test condition | Min. | Typ. | Max. | Unit |
|--|--|---|-------|---------------------------|-------|------|
| General | | | | | | |
| I _{LKGSQH} | Leakage current SQH | V _{S_{DIAG}} = V _{DD} = 0, V _{RES} = 37V, V _{S_{QH}} = 0V | - | - | 50 | μA |
| I _{LKGVRES} | Bias current VRESX | V _{S_{DIAG}} = 18V; V _{DD} = 5V; V _{RES} = 37V; SQH shorted to SQL | - | - | 10 | μA |
| I _{LKGSQ} | Leakage current SQL | V _{S_{DIAG}} = V _{DD} = 0, V _{S_Q} = 18V | -10 | - | 10 | μA |
| I _{PD} | Pulldown current SQL | V _{S_Q} = 1.5V to 20V | 3.3 | - | 4.1 | mA |
| V _{BIAS} | Diagnostics Bias voltage | Nominal 3.6V | -5% | V _{DD} * 0.72 | +5% | V |
| Short to battery/ground diagnostics - R_{sqb} from 0Ω to Open | | | | | | |
| I _{SVRCM} | Maximum diagnostics bias current limit | Short to battery or ground test active V _{S_{QH}} = 0V | 5 | - | 20 | mA |
| R _{STB} | Short to battery resistance threshold | V _{batt} = 6.5V | 1.92 | - | 3.42 | KΩ |
| | | V _{batt} = 16V | 8.61 | - | 13.98 | KΩ |
| | | V _{batt} = 20V | 11.42 | - | 18.42 | KΩ |
| I _{STB} | Short to battery current threshold | - | 0.9 | - | 1.42 | mA |
| R _{STG} | Short to ground threshold | - | 1.07 | - | 2.1 | KΩ |
| I _{STG} | Short to ground current threshold | - | 1.8 | - | 3.2 | mA |

Table 7. Squib deployment drivers and diagnostics - DC electrical characteristics (continued)

| Symbol | Parameter | Test condition | Min. | Typ. | Max. | Unit |
|--|--|--|------|------|------|------------------|
| $t_{\text{DIAGTIMEOUT}}$ | Diagnostic delay time | From/CS \uparrow until Test Results are Valid, Output voltage change 0V to $V_{\text{DD}} * 0.72$ $C_{\text{SQHX}} = 0.12\mu\text{F}$ $C_{\text{SQLX}} = 0.12\mu\text{F}$ | - | - | 300 | μs |
| High side safing diagnostics | | | | | | |
| $I_{\text{SRC_HSS}}$ | Diagnostic current into selected VRESx pin during test | Normal conditions | 710 | - | 950 | μA |
| $I_{\text{HSS_8}}$ | Current during diagnostic | All 8 VRESx pins tied together | 710 | - | 1020 | μA |
| $R_{\text{HSSNORM_th}}$ | Normal resistance range when running high side safing diagnostics | All 8 VRESx pins tied together | 1.4 | - | 2.5 | $\text{K}\Omega$ |
| $V_{\text{HSSNORM_range}}$ | Normal voltage range between VSDIAG and VRESx pin) when running high side safing diagnostics | All 8 VRESx pins tied together | 1.0 | - | 2.5 | V |
| $V_{\text{HSSSHORT_th}}$ | Short voltage threshold between VSDIAG and VRESx pin) | All 8 VRESx pins tied together | 0.5 | - | 1.0 | V |
| $V_{\text{HSSOPEN_th}}$ | Open voltage threshold between VSDIAG and VRESx pin) | All 8 VRESx pins tied together | 2.5 | - | 4.0 | V |
| $t_{\text{DIAGTIMEOUT}}$ | Diagnostic delay time | From/CS \uparrow until test results are valid, $C_{\text{SQHX}} = 0.12\mu\text{F}$ $C_{\text{SQLX}} = 0.12\mu\text{F}$ | - | - | 500 | μs |
| Voltage measurement diagnostics (VRESx) | | | | | | |
| I_{RESx} | Max diagnostic current into VRESx pin | Normal Conditions | - | - | 50 | μA |
| $V_{\text{VRESXLO_th}}$ | Low voltage threshold for VRESx pin | - | 5.0 | - | 7 | V |
| $V_{\text{VRESXHI_th}}$ | High voltage threshold for VRESx pin | - | 13.7 | - | 18.0 | V |
| $t_{\text{DIAGTIMEOUT}}$ | Diagnostic delay time | From/CS \uparrow until test results are valid. | - | - | 100 | μs |

Table 7. Squib deployment drivers and diagnostics - DC electrical characteristics (continued)

| Symbol | Parameter | Test condition | Min. | Typ. | Max. | Unit |
|--|--|---|---------------------|------|---------------------|-------------|
| MOS diagnostics | | | | | | |
| I_{MOS} | MOS test max current | Normal conditions | - | - | I_{SVRCM} | mA |
| $t_{SHUTOFF}$ | LS/HS MOS turn off under fault condition | Time is measured from the valid LS/ HS MOS current > 100mA to the LS/HS turn off | - | - | 4 | μs |
| $t_{FETtimeout}$ | FET timeout | Normal Conditions | - | - | 100 | μs |
| High squib resistance diagnostics | | | | | | |
| R_{SQHIZ} | High load resistance threshold | - | 1.07 | - | 2.1 | k Ω |
| I_{HR} | High resistance current threshold | - | I_{STG} | | | mA |
| $t_{DIAGTIMEOUT}$ | MOS diagnostic delay time | From/CS \uparrow until test results are valid, $C_{SQHX} = 0.12\mu F$ $C_{SQLX} = 0.12\mu F$ | - | - | 300 | μs |
| Squib resistance diagnostics | | | | | | |
| V_{OH} | Output voltage AOUT | High saturation voltage; $I_{AOUT} = -500\mu A$ | VDD-0.2 | - | - | V |
| V_{OL} | | Low Saturation Voltage; $I_{AOUT} = +500\mu A$ | - | - | 0.2 | V |
| I_Z | Tri-State Current AOUT | AOUT = VDD | - | - | 1 | μA |
| | | AOUT = 0V | -1 | - | | μA |
| $R_{SQB RANGE}$ | Load resistance range | - | 0 | - | 10.0 | Ω |
| V_{AOUT} | Resistance measurement analog output tolerance $V_{AOUT} =$ $VDD \cdot \left[\frac{1}{9.75} + \left(0.08 \cdot \frac{R_{SQB}}{\Omega} \right) \right]$ | $0\Omega \leq R_{SQB} < 3.5\Omega$ | $V_{AOUT} - 0.095V$ | - | $V_{AOUT} + 0.095V$ | V |
| | | $3.5\Omega \leq R_{SQB} \leq 10\Omega$ | $V_{AOUT} - 0.95V$ | - | $V_{AOUT} - 1.05V$ | V |
| I_{SRC} | Resistance measurement current source | $V_{DD} = 5.0V$; $V_{SDIAG} = 7.0V$ to 37V | 38 | - | 42 | mA |
| I_{SINK} | Resistance measurement current sink | IPD OFF, $V_{SQLX} = 4 V$ | 45 | - | 57 | mA |
| I_{SLEW} | Rmeas current di/dt | 30% - 70% of ISRC | 2 | - | 11 | mA/ μs |
| V_{cmpr} | Voltage threshold on squib pin to shutdown ISRC | - | 2.65 | - | 3.25 | V |
| $t_{srcshtdwn}$ | Shutdown time | Guaranteed by design | - | - | 30 | μs |
| $V_{LSDrsqb}$ | LSD (V_{SQL}) voltage during resistance measure | - | 0.8 | - | 2.2 | V |

Table 7. Squib deployment drivers and diagnostics - DC electrical characteristics (continued)

| Symbol | Parameter | Test condition | Min. | Typ. | Max. | Unit |
|---------------------------|---|---|-----------------------|------|-----------------------|----------|
| t_{R_WAIT} | Rmeas wait time | Wait time before AOUT voltage is stable for ADC reading R AOUT= 5.1k Ω ; C _{AOUT} =10nF | - | - | 300 | μ s |
| FENx input pins | | | | | | |
| $t_{FENfilter}$ | Minimum pulse width | - | 12 | - | 16 | μ s |
| I_{FENPD} | Internal pull-down current | VIN = VIL to VDD | 20 | - | 50 | μ A |
| V_{FENLO} | Input low voltage threshold | - | 0.8 | - | - | V |
| V_{FENHI} | Input high voltage threshold | - | - | - | 2.0 | V |
| $T_{FENLATCH}$ | FEN Latch timer | - | 0 | - | 512 | ms |
| t_{FLACC} | FEN latch timer accuracy | - | - 20% | - | 20 | % |
| Deployment drivers | | | | | | |
| $T_{RESOLUTION}$ | Diagnostic timing / resolution | $I_{HS} \geq I_{MEAS}$, $0s \leq T_{MEASURE_TIME} \leq 3.7ms$ | 22.5 | 25 | 27.5 | μ s |
| $T_{ACCURACY}$ | Diagnostic time accuracy | $C_{SQUIB_HI} = 0.12\mu F$ $C_{SQUIB_LO} = 0.12\mu F$ | - | - | 2 | LSB |
| I_{MEAS} | High side driver current limit detect threshold | Guaranteed by design | $I_{HSX} \times 0.90$ | - | $I_{HSX} \times 0.99$ | A |
| $R_{DSONTOTAL}$ | Total high and low side MOS on resistance | High side MOS + low side MOS D9:D8="11"; $V_{RES} = 7V$; $I = 1.6A$ @95°C | - | - | 2.0 | Ω |
| R_{DSONHS} | High side MOS on resistance | D9:D8="11"; $V_{RES} = 7V$; $T_{amb} = 95^\circ C$; $I_{VRES} = 1.6A$; | - | 0.3 | 0.8 | Ω |
| R_{DSONLS} | Low side MOS on resistance | | - | 0.6 | 1.2 | Ω |
| I_{HS_12A} | High side deployment current limit | Configuration mode 1 bits D9:D8="00" SQHx shorted to ground; $V_{RES} = 7$ to 37V | 1.21 | - | 1.47 | A |
| I_{HS_15A} | | Configuration Mode 1 bits D9:D8="01" SQHx shorted to ground; $V_{RES} = 7$ to 25V | 1.51 | - | 1.85 | A |
| I_{HS_175A} | | Configuration Mode 1 bits D9:D8="11" SQHx shorted to ground; $V_{RES} = 7$ to 37V | 1.76 | - | 2.14 | A |
| t_{LIM} | Low side MOS shutdown under short to battery | $V_{sqblo}=18V$ | 90 | - | 110 | μ s |
| I_{LS} | Low side MOS current limit | | 2.2 | - | 4.0 | A |

Table 7. Squib deployment drivers and diagnostics - DC electrical characteristics (continued)

| Symbol | Parameter | Test condition | Min. | Typ. | Max. | Unit |
|---------------------|------------------------------|--|------|------|------|---------|
| t_{settle} | Firing current settling time | Time from fire command CS_D rising edge to where firing current remains within specified limits $C_{SQIB_HI} = 0$ to $0.12\mu F$ $C_{SQIB_LO} = 0$ to $0.12\mu F$ | - | - | 150 | μs |
| $t_{DEPLOY-2ms}$ | Deployment time | $V_{RES} = 7V$ to $37V$ @ I_{HS_12A} $V_{RES} = 7V$ to $25V$ @ I_{HS_15A} For I_{HS_12A} and I_{HS_15A} Firing current measured from CS_D rising edge | 2.15 | - | 2.5 | ms |
| $t_{DEPLOY-1ms}$ | | $V_{RES} = 7V$ to $37V$ For I_{HS_175A} Firing current measured from CS_D rising edge | 1.15 | - | 1.40 | ms |
| $t_{DEPLOY-0.65ms}$ | | $V_{RES} = 7V$ to $37V$ For I_{HS_175A} Firing current measured from CS_D rising edge | 0.65 | - | 0.85 | ms |

Figure 3. MOS settling time and turn-on time 2

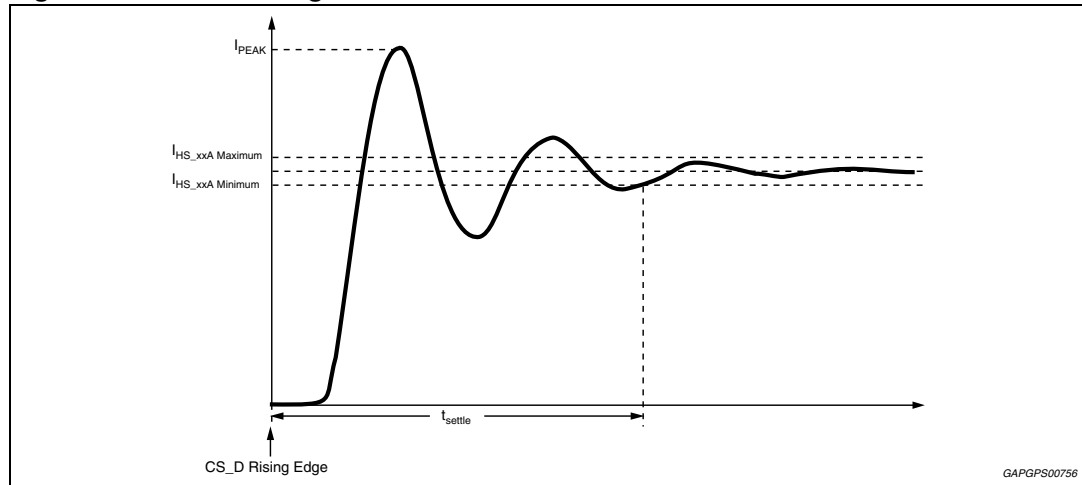

2.4.3 SPI timing

All SPI timing is performed with a 150 pF load on MISO unless otherwise noted

$4.9V \leq V_{DD} \leq 5.1V$; $7V \leq V_{RESX} \leq 37V$; $7V \leq V_{SDIAG} \leq 37V$; FEN1 = FEN2 = FEN3 = FEN4 = V_{DD} ; R_REF = 10K Ω , $\pm 1\%$, 100PPM; $-40^{\circ}C \leq T_A \leq +95^{\circ}C$; C_VRES0_1 \geq 68nF; C_VRES2_3 \geq 68nF; C_VRES4_5 \geq 68nF; C_VRES6_7 \geq 68nF; unless other specified.

Table 8. SPI timing - DC electrical characteristics

| No. | Symbol | Parameter | Min. | Typ. | Max. | Unit |
|-----|---------------------|--|------|------|------|------|
| - | fop | Transfer frequency | dc | - | 5.50 | MHz |
| 1 | tsCK | SCLK Period | 181 | - | - | ns |
| 2 | tLEAD | Enable Lead Time | 65 | - | - | ns |
| 3 | tLAG | Enable Lag Time | 50 | - | - | ns |
| 4 | tsCLKHS | SCLK, High Time | 65 | - | - | ns |
| 5 | tsCLKLS | SCLK, Low Time | 65 | - | - | ns |
| 6 | tsUS | MOSI, Input Setup Time | 20 | - | - | ns |
| 7 | tHS | MOSI, Input Hold Time | 20 | - | - | ns |
| 8 | tA | MISO, Access Time | - | - | 60 | ns |
| 9 | tDIS ⁽¹⁾ | MISO, Disable Time | - | - | 100 | ns |
| 10 | tVS | MISO, Output Valid Time | - | - | 60 | ns |
| 11 | tHO ⁽¹⁾ | MISO, Output Hold Time | 0 | - | - | ns |
| 12 | tRO | Rise Time (Design Information) | - | - | 30 | ns |
| 13 | tFO | Fall Time (Design Information) | - | - | 30 | ns |
| 14 | tCSN | CS_D, Negated Time | 640 | - | - | ns |
| 15 | tCLKN | Time between CS rising edge and first transition of SCLK must be higher than tCLKN. It happens when multiple devices are connected to the same SCLK and MOSI but with different chip select. | 500 | - | - | ns |

1. Parameters t_{DIS} and t_{HO} shall be measured with no additional capacitive load beyond the normal test fixture capacitance on the MISO pin. Additional capacitance during the disable time test erroneously extends the measured output disable time, and minimum capacitance on MISO is the worst case for output hold time.

Figure 4. SPI timing diagram

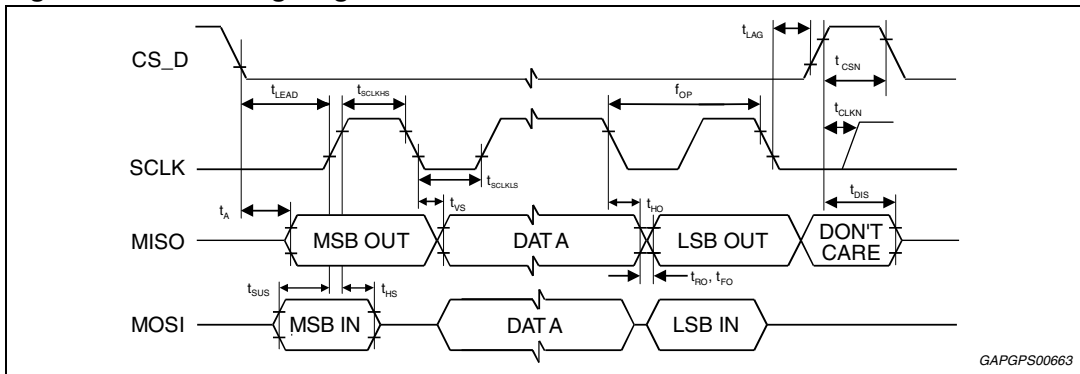
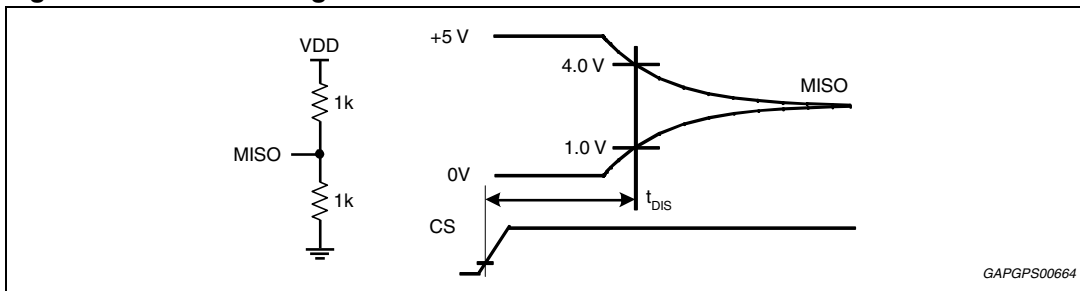

Figure 5. MISO loading for disable time measurement



3 Functional description

3.1 Overview

The L9659 is an integrated circuit to be used in air bag systems. Its main functions include deployment of air bags. The L9659 supports 8 deployment loops.

3.2 General functions

3.2.1 Power on reset (POR)

The ASIC has a power on reset (POR) circuit, which monitors VDD voltage. When VDD voltage falls below V_{RST1} for longer than or equal to t_{POR} , all outputs are disabled and all internal registers are reset to their default condition. A second reset level, V_{RST2} , also monitors VDD but uses no filter time and will disable all outputs and all internal registers are reset to their default condition when VDD falls below the reset threshold.

Figure 6. POR timing

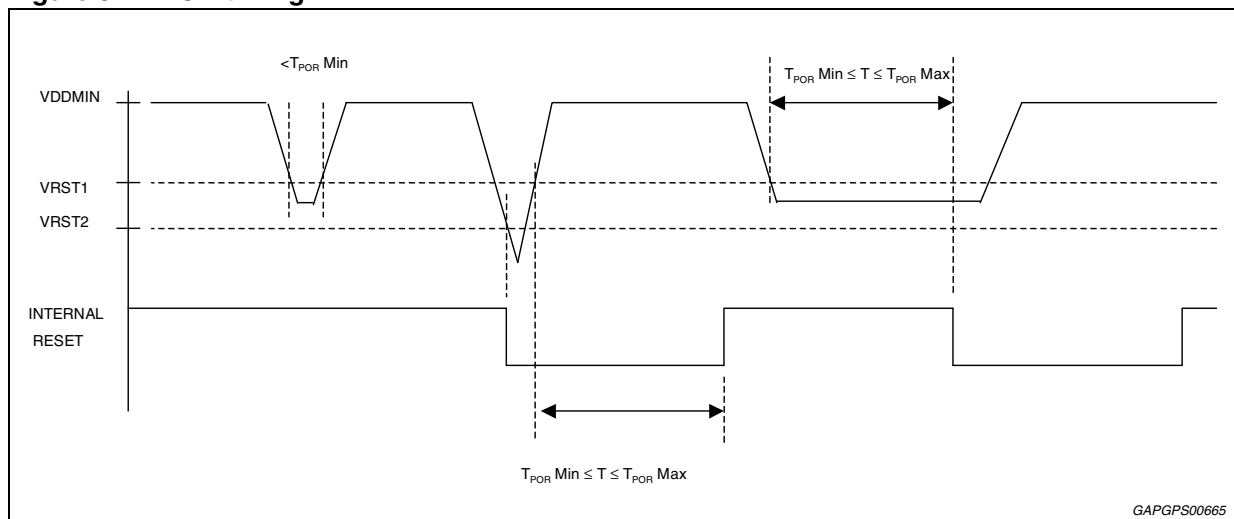

3.2.2 RESETB

The RESETB pin is active low. The effects of RESETB are similar to those of a POR event, except during a deployment. When a deployment is in-progress, the L9659 will ignore the RESETB signal.

However, it will shut itself down as soon as it detects a POR condition. When the deployment is completed and RESETB signal is asserted, the L9659 disables its outputs and reset its internal registers to their default states.

A de-glitch timer is provided for the RESETB pin. The timer protects this pin against spurious glitches. The L9659 neglects RESETB signal if it is asserted for shorter than t_{GLITCH} . RESETB has an internal pull-up in case of an open circuit.

3.2.3 Reference resistor

IREF pin shall be connected to VDD supply through a resistor, RIREF. When the L9659 detects the resistor on IREF pin is larger than RIREF_H or smaller than RIREF_L, it goes into a reset condition. All outputs are disabled and all internal registers are reset to their default conditions.

3.2.4 Loss of ground

GND

When the GND pin is disconnected from PC-board ground, the L9659 goes in reset condition. All outputs are disabled and all internal registers are reset to their default conditions.

GND0-GND7

A loss of power-ground (GND0 – GND7) pin/s disables the respective low side driver/s on SQLx. However, the high side driver of the respective channel will still be able to be turned on. Thus under the scenario where the low side is shorted to ground the L9659 will be able to provide the programmed firing current for the specified time.

An open GNDx connection on any channel has no affect on the other channels. An open GNDx condition will be detected using the low side MOS diagnostics.

AGND

The AGND pin is a reference for AOUT pin. When AGND loses its connection, the voltage on AOUT pin is pulled up to VDD voltage and L9659 goes in reset condition. All outputs are disabled and all internal register are reset to their default conditions.

3.2.5 VRESx capacitance

To ensure all diagnostics function properly a typical capacitor of equal to or greater than 68nF is required close to the firing supply pins. Thus minimum of 4 capacitors are required with one placed close to the VRES0 and VRES1 pins and a second capacitor will be close to the VRES2 and VRES3 pins and a third capacitor will be close to the VRES4 and VRES5 pins and a forth capacitor will be close to the VRES6 and VRES7 pins.

3.2.6 Supply voltages

The primary current sources for the different functions of the ASIC are as follows:

- VRESx - Firing currents along with HSS and HS FET diagnostic currents
- VSDIAG - Squib resistance and HSS diagnostics
- VDD will be used for all internal functions as well as short to battery/ground and high squib resistance diagnostics.

3.2.7 Ground connections

GND pin (6) is not connected internally to other ground pins (AGND or power ground GNDx). A ground plane is needed to directly connect the GND pin. This ground plane needs to be isolated from the high current ground for the squib drivers to prevent voltage shifts.

AGND pin should be connected to ground plane too to minimize drop versus ground reference of ADC that capture AOUT voltage.

3.3 Serial peripheral interface (SPI)

The L9659 contains one serial peripheral interfaces for control of the squib functions. The following table shows features that are accessed/controlled by the SPI.

Table 9. Features that are accessed/controlled for the SPI

| Function | Pin names | Features accessed |
|-------------------------------------|------------------------------|---|
| Squib diagnostic and deployment SPI | SCLK MISO MOSI CS_D | All Squib Diagnostics; Squib related status information; Squib Arming and Firing; Software Reset; Component ID & Revision |

The software reset accessed over SPI will reset squib functions. The L9659 has a counter to verify the number of clocks in SCLK. If the number of clocks in SCLK is not equal to 16 clocks while CS_D is asserted, it ignores the SPI message and sends a SPI fault response. L9659 computes SPI error length flag through counting the number of SCLK rising edges occurring when CS_D is active. If the first SCLK rising edge occurs when CS_D is inactive and the falling edge occurs when CS_D is low, it is considered as valid edge.

MOSI commands contain several bits not used, all those bits must be 0. Commands are not recognized valid if one or more not used bits are not 0.

3.3.1 SPI pin descriptions

Chip select (CS_D)

Chip-select inputs select the L9659 for serial transfers. CS_D can be asserted at any given time and are active low. When chip-select is asserted, the respective MISO pin is released from tri-state mode, and all status information is latched into the SPI shift register. While chip-select is asserted, register data is shifted into MOSI pin and shifted out of MISO pin on each subsequent SCLK. When chip-select is negated, MISO pin is tri-stated. To allow sufficient time to reload the registers; chip-select pin shall remain negated for at least tCSN. The chip-select inputs have current sinks which pull these pins to the negated state when there is an open circuit condition. These pins have TTL level compatible input voltages allowing proper operation with microprocessors using a 3.3 to 5.0 volt supply.

Serial clock (SCLK)

SCLK input is the clock signal input for synchronization of serial data transfer. This pin has TTL level compatible input voltages allowing proper operation with microprocessors using a 3.3 to 5.0 volt supply. When chip select is asserted, both the SPI master and L9659 will latch input data on the rising edge of SCLK. The L9659 shifts data out on the falling edge of SCLK.

Serial data output (MISO)

MISO output pins shall be in one tri-state condition when chip select is negated. When chip select is asserted, the MSB is the first bit of the word/byte transmitted on MISO and the LSB is the last bit of the word/byte transmitted. This pin supplies a rail to rail output, so if interfaced to a microprocessor that is using a lower VDD supply, the appropriate microprocessor input pin shall not sink more than IOH(min) and shall not clamp the MISO output voltage to less than VOH(min) while MISO pin is in a logic "1" state. When connecting to a micro using a lower supply, such as 3.3V, a resistor divider shall be used with high enough impedance to prevent excess current flow.

Serial data input (MOSI)

MOSI inputs take data from the master processor while chip select is asserted. The MSB shall be the first bit of each word/byte received on MOSI and the LSB shall be the last bit of each word/byte received.

This pin has TTL level compatible input voltages allowing proper operation with microprocessors using a 3.3 to 5.0 volt supply.

3.4 Squib drivers

3.4.1 Firing

The on-chip deployment drivers are designed to deliver 1.2A (min) for 2ms (min) and 1.75A (min) for 1ms (min) and 1.75A (min) for 0.65ms (min) with VRESx voltages between 7V and 37V. In addition the L9659 can provide 1.5A minimum for 2ms for VRESx voltages between 7V and 25V. The firing condition is selectable via the SPI. At the end of a deployment, a deploy success flag is asserted and can be read using the appropriate SPI command. Each VRESx and GNDx connection is used to accommodate 8 loops that can be deployed simultaneously.

Upon receiving a valid deployment condition, the respective SQHx and SQLx drivers are turned on. The only other activation of the SQHx and SQLx drivers is momentarily during a MOS diagnostic. Otherwise, SQHx and SQLx are inactive under any normal, fault, or transient conditions. Upon a successful deployment of the respective SQHx and SQLx drivers, a deploy command success flag is asserted via SPI. Refer to [Figure 8](#) for the valid conditions and the deploy success flag timing.

The L9659 is protected against inadvertent turn on of the firing drivers unless the appropriate conditions are present. Non-typical conditions will not cause driver activation. This includes the case where VRESx and/or VSDIAG pins are connected to a supply up to 40V and VDD is between 0V and VDD min. Under these conditions the L9659 will ensure that driver activation will not occur. No flow of current shall be allowed through the SQHx and SQLx pins.

Figure 7. Deployment drivers diagram

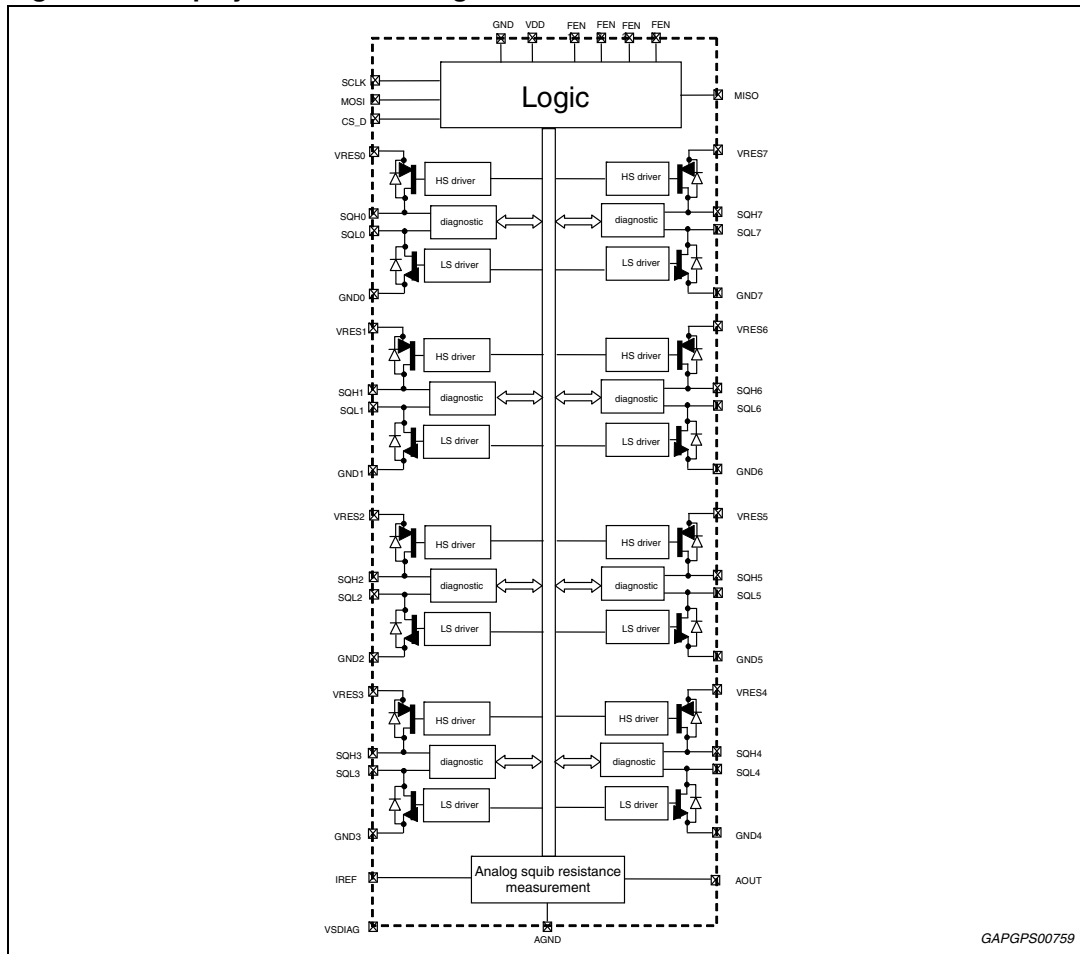

Driver activation

The firing of a squib driver requires the appropriate FEN function to be active and two separate sixteen bit writes be made over the SPI. The FEN function is defined as the result of the FENx pin OR'd with the internal FENx latch. The FENx pin going high initiates the FEN function. With the FEN 1 function being active and the appropriate Arm and Fire commands sent then Squib_0 & 1 drivers would be activated. With the FEN 2 function being active and the appropriate Arm and Fire commands sent then Squib_2 & 3 drivers would be activated. With the FEN 3 function being active and the appropriate Arm and Fire commands sent then Squib_4 & 5 drivers would be activated. With the FEN 4 function being active and the appropriate Arm and Fire commands sent then Squib_6 & 7 drivers would be activated.

The first write is to ARM the drivers in preparation of receiving the fire command. The Arm command will stop on all channels any diagnostics that are active. Any combination of squibs can be armed. The second write is a FIRE command that must directly follow the Arm command and will activate the desired driver pairs assuming the FEN function is valid. If there is a parity mismatch the data bits will be ignored and the squib drivers will not have their status changed, and the two write sequence must then be started again. If there is a mismatch in channels selected then only those channels selected in both the Arm and Fire commands will be activated.

During the first write, when the drivers are armed, all diagnostic functions are cleared. The FIRE command must follow the ARM command along with the FEN function active for driver activation. If a command is between the ARM and FIRE command then the sequence must be restarted. An error response will be received for the Fire command if the ARM/FIRE sequence is not followed.

The ARM/FIRE commands and FEN function are independent from each other. The L9659 will begin the t_{DEPLOY} timer once a valid ARM/FIRE sequence has been received. If a valid ARM/FIRE command has been sent and the FEN function is inactive then the drivers will not be activated but the t_{DEPLOY} timer will start. If the FEN function becomes active before t_{DEPLOY} has expired then the drivers will become active for the full t_{DEPLOY} time. If the FEN does not become active before t_{DEPLOY} has expired then the sequence would need to be restarted. A diagram illustrating this is shown in *Figure 8*.

Figure 8. Driver activation timing diagram

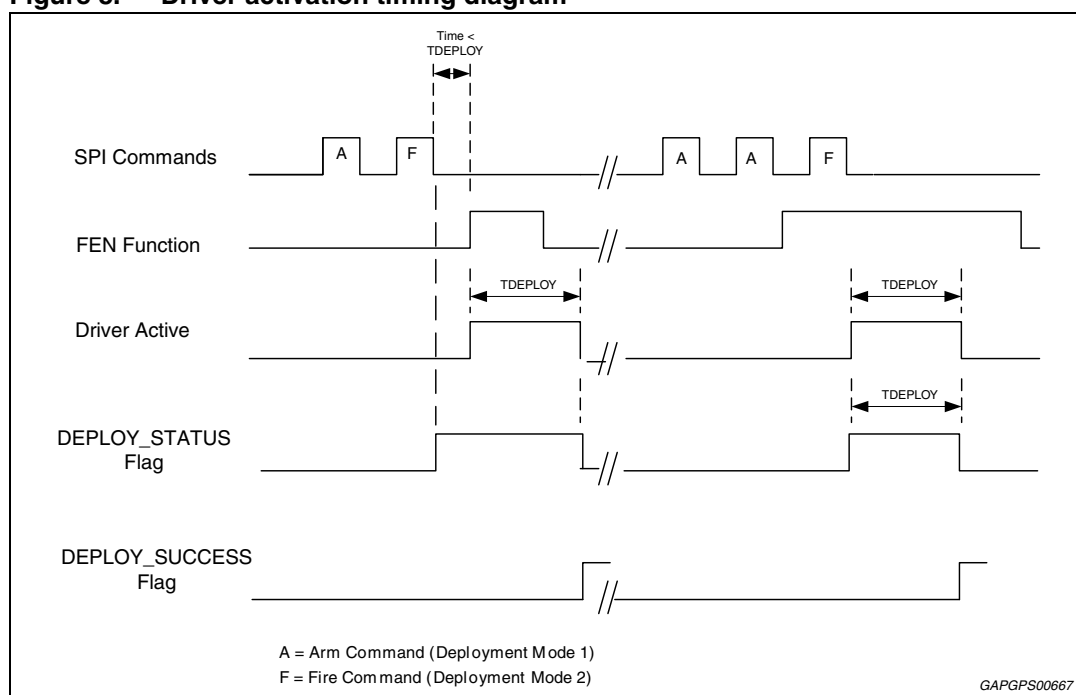

Only the channels selected in the ARM and, directly following, the FIRE command will be able to be activated.

By reading the appropriate registers a status of the deployment is provided. If a valid Arm/Fire sequence has been provided the status flag will become active. This flag will remain active for as long as the T_{DEPLOY} timer is counting. Depending on the state of the FEN function the DEPLOY_STATUS flag will be active a minimum of T_{DEPLOY} and a maximum of $2 \times T_{DEPLOY}$. If driver activation did occur (both a valid Arm/Fire sequence and the appropriate FEN function active within the appropriate time) then the DEPLOY_SUCCESS flag will be active following the completion of the driver activation period. This flag will be active until cleared by software. If a valid Arm/Fire sequence did occur but the FEN function was never activated within the T_{DEPLOY} time then the DEPLOY_SUCCESS flag will remain '0'.

Once the Deploy Success Flag is set, it will inhibit the subsequent deployment command until a SPI command to clear this deployment success flag is received. Bits D7 through bit D0 are used to clear/keep the deploy success flag. When these bits are set to '1,' the flag

can be cleared. Otherwise, the state of these flags is not affected. The Success flag must be cleared to allow re-activation of the drivers.

During driver activation the respective high side (SQHx) and low side (SQLx) drivers will turn on for t_{DEPLOY} .

L9659 driver activation will not occur or, if firing is in process, will terminate under the following conditions:

- Power On Reset (POR)
- IREF resistance is larger than RIREF_H or smaller than RIREF_L
- Loss of ground condition on GND pin

The following conditions are ignored when driver activation is in-progress:

- RESETB
- Valid soft reset sequences
- SPI commands except as noted below. Response for ignored commands will be 0xD009
- FEN function

The following table shows the response when sending SPI commands during deployment.

Table 10. SPI MOSI/MISO response

| SPI MOSI | SPI MISO | Response |
|------------------------|--------------------|--|
| Configuration Commands | SPI fault response | MOSI register mode messages will be ignored |
| Deployment Commands | Command mode | Execute for channels not in deployment; no effect to deploying channel |
| Diagnostic Commands | SPI fault response | MOSI diagnostic mode messages will be ignored |
| Monitor Commands | Status response | Execute for all channels |

Note 1: SPI MISO sent in the next SPI transmission.

The L9659 can only deploy a channel when the FEN function is active. Once the drivers are active the L9659 will keep the drivers on for the required duration regardless of the FEN state. Once complete a status bit will be set to indicate firing is complete.

3.4.2 Firing current measurement

All channels have a 7 bit current measurement register that is used to measure the amount of time the current is above I_{MEAS} during firing. The maximum measurement for each channel is 3.175ms nominal based on a bit weight of 25 μ s. The current measurement register will not increment outside the deployment time. The current measurement will begin incrementing once the current has exceeded 95% of the nominal target value. The count will continue to increment from the stored value until either a clear command has been issued for that channel or all '1's are present in the corresponding channel measurement register. If all '1's are present for a channel's measurement register and another firing sequence has been issued the register will remain all '1's. Only if a clear command has been issued will that particular register be reset to all '0's. All other channels shall keep the stored measurement count. During firing the current measurement register cannot be cleared. After a clear command has been issued for a channel then the channel is ready to count if

the current exceeds the specified level. After a POR or software reset the L9659 will reset all 8 measurement registers to all '0's.

A "real-time" current measurement status of all the channels is available. If a current limit status request is sent then the L9659 will report in the next SPI transfer whether the current is above or below IMEAS for each of the channels. The current status results can be read at any time and will correctly report whether current is flowing. The content of the internal current status register is captured on the falling edge of chip select during the SPI response. The internal status register is updated at a nominal sample time of 25µs and is independent of SPI transfers.

For this circuit there is continuously being performed compensation of the comparator to remove offset errors, which is independent from SPI commands. The compensation is being performed every 12.8µs based on the internal clock.

3.4.3 Fire enable (FEN) function description

The Fire Enable (FEN) function is the result of the FENx input OR'd with the internal FEN latch. If the FEN latch is not enabled and the FENx pin is low then activation of the FET drivers are disabled except as indicated during the MOS test. All internal diagnostic functions, and results, will be available through the serial interface. This pin must be pulled high to initiate the FEN latch function (if programmed) and enable firing of the FET drivers.

There are four FEN function blocks

- FEN Function 1 is FEN1 input OR'd with FEN1 latch timer and used for enabling channels 0 & 1
- FEN Function 2 is FEN1 input OR'd with FEN2 latch timer and used for enabling channels 2 & 3
- FEN Function 3 is FEN1 input OR'd with FEN3 latch timer and used for enabling channels 4 & 5
- FEN Function 4 is FEN1 input OR'd with FEN4 latch timer and used for enabling channels 6 & 7

The FEN function will be considered active when the pin is active ('1' or high) for more than 12 microseconds. Tolerance range for the filter used is 12 to 16 µsecs.

When the FENx input is active, '1', the FEN function will be active. **When the FENx input state transitions from '1' to '0', the programmable latching function will hold the FEN function active until the timeout of the FEN timer.** The programmable latch and hold function will be capable of delays of 0ms, 128 ms, 256 ms, and 512 ms. There are 4 independent timers with the timer for FEN1 associated with channels 0 & 1, timer for FEN2 associated with channels 2 & 3, timer for FEN3 associated with channels 4 & 5, timer for FEN4 associated with channels 6 & 7. **The timer is reset to the programmed time when the FENx pin transitions from '0' to '1'.** The programmable counter delay will be set through a SPI command.

3.4.4 Squib diagnostics

Overview

The ASIC is able to perform the following diagnostics

- Short to battery and ground on both SQHx and SQLx pins with or without a squib
- Loop to loop diagnostics
- Squib resistance measurement
- Squib High resistance
- High side safing FET diagnostics
- VRESx voltage status
- High and low side FET diagnostics

Below is a block diagram showing the components involved in the squib diagnostics.

Figure 9. Squib diagnostics block diagram

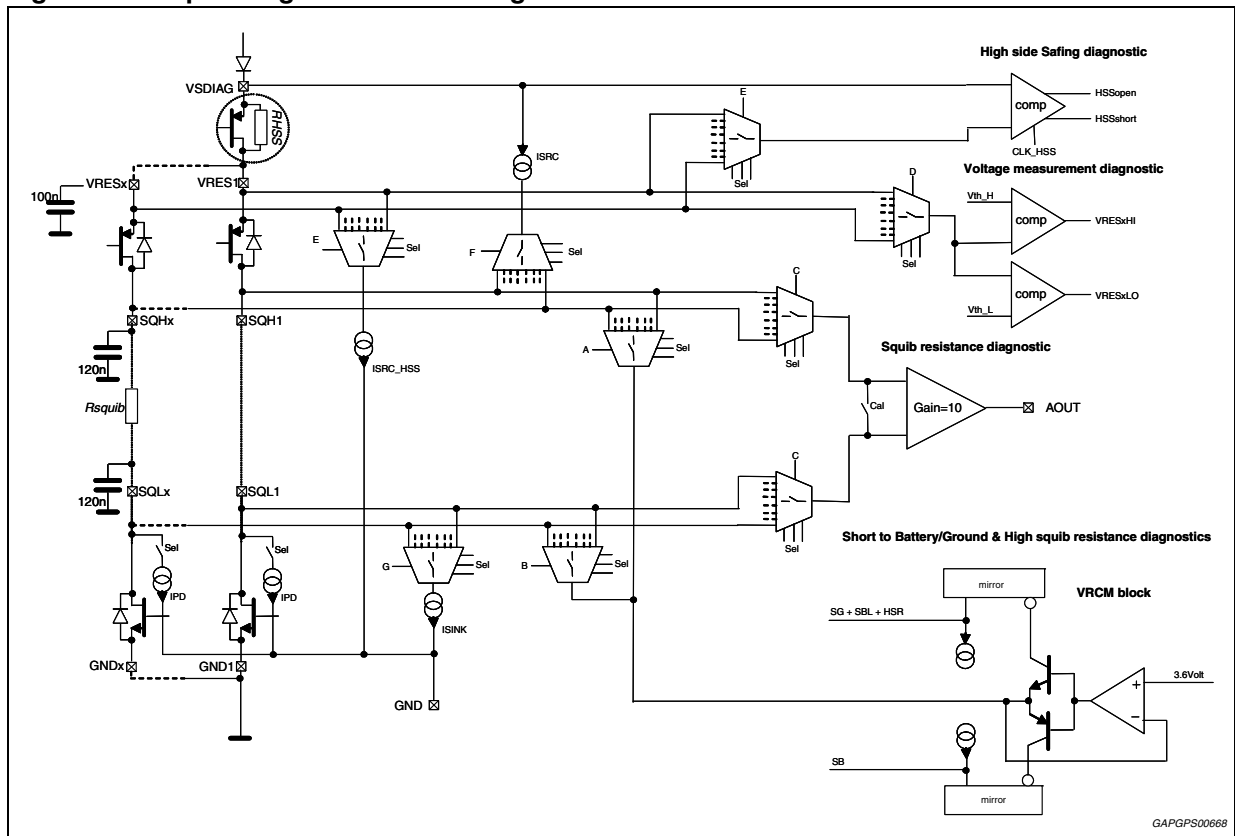

Short to battery/ground and loop to loop diagnostics

The leakage diagnostic includes a short to battery, a short to ground and a short between loop tests. The test will be run for each SQHx and SQLx pin so that shorts can be detected regardless of the resistance between the squib pins.

Normal short to battery/ground diagnostics.

For the test the internal VRCM is switched on and connected to the selected pin (SQHx or SQLx) pin. The IPD bit will be selected to be OFF which will deactivate the pulldown current

on the channel under test and all other channels. During the test with no leakage present the voltage on the selected SQHx or SQLx pin will be equal to VBIAS and no current is sunk or sourced by VRCM. If a leakage to ground, battery or to SQLy is present, the VRCM will sink or source a current less than I_{SVRCM} trying to keep VBIAS. Two current comparators, ISTB and ISTG, will detect the abnormal current flow.

Loop to loop diagnostics

For this test the same procedure is followed except the pulldown current (IPD) is selected to be ON which will deactivate the pulldown current only on the channel under test with all other channel pulldown currents active. If a short to ground fault is active, assuming it was not active during normal short to battery/ground diagnostics, then that particular channel has a short to another squib loop. To detect loop to loop shorts between ASICs in the system the Stop diagnostics command with IPD enabled needs to be sent to the other ASICs before running the loop to loop diagnostics on the channel to be monitored. If the channel being monitored has a short to ground fault active, assuming it was not active during normal short to battery/ground diagnostics, then that particular channel has a short to another squib loop in the system.

The following table indicated how faults would be interpreted.

Table 11. How faults shall be interpreted

| Fault condition for channel ⁽¹⁾ | Channel leakage diagnostics results with I _{PD} ON | Channel leakage diagnostics results with I _{PD} OFF |
|--|---|--|
| No Shorts | No Fault | No Fault |
| Short to battery | STB Fault | STB Fault |
| Loop to loop short | STG Fault | No Fault |
| Short to ground | STG Fault | STG Fault |

1. Condition where 4 open channels have the SQHx pins shorted will not be detected. If one squib is open and the other has a normal squib connection then the fault will be indicated on the channel that is open. Assumes both pins are tested

Once the command is issued the state of the comparators will be captured on the next falling edge of CS_D. The results are valid after T_{SHORTDIAG} time, which is mainly dependant on the external capacitors on the squib lines.

Squib resistance measurement

During a resistance measurement, both ISRC and ISINK are switched on and connected to the selected SQHx and SQLx channel. A differential voltage is created between the SQHx and SQLx pin based in the ISRC current and resistance between the pins. The analog output pin, AOUT, will provide the resistance-measurement voltage based on the scaling factor indicated in the electrical parameters section. The tri-state output, AOUT, will be connected to an ADC input of a microprocessor. When not running squib resistance diagnostics the AOUT pin will be high impedance.

To increase accuracy of the squib resistance measurements the offset of the internal amplifier can be provided on the AOUT pin. This is done by setting the appropriate calibration bit, waiting the required time, and reading the converted AOUT voltage connected to the microprocessor ADC.

The normal measurement method for squib resistance is to take a single ended analog output measurement for a channel (V_{AOUT} with AMC bit=0) and use the tolerances and

equation shown in the parametric table. The L9659 is also capable of improving the tolerance at resistances below 3.5 Ohms by removing the offset of the differential comparator. This method works taking the single ended analog output results for a channel (V_{AOUT} with AMC bit=0) and subtracting the internal comparator offset measurement of V_{AOUT_CAL} (V_{AOUT} with AMC bit=1). The summary of the equation for this is as follows:

$$A_{OUT_CAL} = (V_{AOUT} - V_{AOUT_CAL})/VDD$$

$$A_{OUT_CAL} \text{ typical} = 0.08 \times R_{SQUIB}$$

High squib resistance diagnostics

During a high squib resistance diagnostic, VRCM and ISINK are switched ON and connected to SQHx and SQLx on the selected channel. Current flowing on SQHx will be measured and compared to IHR threshold to identify if resistance is above or below RSQHZ. The results will be reported in the next SPI message. Once the command is issued the state of the squib resistance will be valid after THSR captured on the next falling edge of CS_D. The voltage source for this test will be VBIAS which is based on the VDD supply.

A way to reduce the time required until valid results are available is to perform a leakage diagnostics prior to this test. The leakage diagnostics will bias the voltage on the squibs to around 3.5V, which is the same bias voltage required for the high squib resistance diagnostic. By following running this sequence of diagnostics will reduce the test time to from 1.5ms to 200µs.

High and low side FET diagnostics

Prior to either the HS or LS FET diagnostics being run it is required to have the VRCM switched ON. Running the leakage diagnostics with the appropriate delay time prior to either the HS or LS FET diagnostics can do this. When the FET diagnostic command is issued the flags will initially be cleared. If the VRMC is not active or some leakage is present then the MOS will not be turned ON, the test will be aborted and Fault Present (FP) bit will be set. The FEN function must be inactive to run test. The test will not start if FEN function is active on channel under test and it will result in the Fault Present (FP) bit to set.

If no leakage is present and FEN function is inactive, the MOS (High side or Low Side) is turned ON. The L9659 will monitor the current sink or sourced by VRCM. If the MOS is working properly, this current will exceed ISTB (HS test) or ISTG (LS test) and the L9659 will turn off the driver under test within the specified time $T_{SHUTOFF}$. If the current does not exceed ISTB or ISTG then the test will be terminated and the MOS will be switched off by the L9659 within $T_{FETTIMEOUT}$. During the $T_{FETTIMEOUT}$ period the FET Timeout bit will be set (FT=1) and will be cleared at the expiration of the timer.

The results must be compared with the leakage diagnostic results to distinguish between a real leakage/short versus a FET fault. For high side FET diagnostics if no faults were indicated in the preceding leakage diagnostics then a normal result would be STB=1;STG=0 (with FT=0;FP=0). If the returned results for the high side FET test is not STB=1;STG=0 (with FT=0;FP=0) then either the FET is not functional, a short occurred during the test, or there is a missing VRESx connection for that channel. For low side FET diagnostics if no faults were indicated in the preceding leakage diagnostics then a normal result would be STB=0;STG=1 (with FT=0;FP=0). If the returned results for the low side FET test is not STB=0;STG=1 (with FT=0;FP=0) then either the FET is not functional, a short occurred during the test, or there is a missing GNDx connection for that channel. If the test is in progress then a bit (FT) is used in the response to indicate this status.

Once the command is issued, output of comparators will be latched.

On the next falling edge of CS_D, comparator latched data are captured and reported to MISO response. The results will remain latch until the next test is initiated (diagnostic write command). If the test is in progress then a bit is used in the response to indicate the test completion. If the FET under test is working properly then the results will indicate a “Short to Ground” for LS test and “Short to Battery” for HS test. If a leakage is present prior to the test or FENx is asserted then both “Short to Ground” and Short to Battery” will be indicated in the response for either a LS or HS FET test.

For all conditions the current on SQHx/SQLx will never exceed I_{SVRCM} . On the squib lines there will be higher transient currents due to the presence of the filter capacitor.

High side safing diagnostics

When the command is received the L9659 will activate IHSS on the selected VRESx. The diagnostics will measure the difference between VSDIAG and VRESx. The internal comparator will detect open, short or normal condition based on the differential voltage between VSDIAG and VRESx.

The results will be reported in the next SPI message using bits HSS1 and HSS0 as indicated in the following table. Once the command is issued the voltages will be captured on the next falling edge of CS_D.

Table 12. Diagnostic Mode HSS selection

| Condition | HSS1 | HSS0 |
|---|------|------|
| $(VSDIAG - VRESx) < V_{HSSSHORT_th}$ | 0 | 0 |
| $V_{HSSSHORT_th} < (VSDIAG - VRESx) < V_{HSSOPEN_th}$ | 0 | 1 |
| $V_{HSSOPEN_th} < (VSDIAG - VRESx)$ | 1 | 1 |

Voltage measurement diagnostics (VRESx)

When the command is received the L9659 will activate a comparator for the selected channel. A 2 bit indication of the state of the VRESx pins will be reported as indicated below. The results will be reported in the next SPI message. Once the command is issued the voltages will be captured on the next falling edge of CS_D.

Table 13. Diagnostic mode 3 VRESx selection

| Condition | VR1 | VR0 |
|--|-----|-----|
| $V_{RESx} < V_{VRESXLO_th}$ | 0 | 0 |
| $V_{VRESXLO_th} < V_{RESx} < V_{VRESXHI_th}$ | 0 | 1 |
| $V_{VRESXHI_th} < V_{RESx}$ | 1 | 1 |

Loss of power ground

When any of the power grounds (GND0 – 7) are lost, no deployment can occur on the respective deployment channels because the low side driver will be inactive. The high side driver for the respective channel can still be activated.

A loss of ground condition on one or several channels will not affect the operation of the remaining channels. When a loss of ground condition occurs, the source of the low side MOS will be floating. In this case, no current will flow through the low side driver.

This condition will be detected as a fault by a low side MOS diagnostic. No additional faults will be reported from any other diagnostic due to this condition.

3.4.5 SPI register definition for squib functions

The SPI provides access to read/write to the registers internal to the L9659. All commands and responses sent to/from the L9659 on SPI will use set D13 as required for odd parity on the 16 bit word. The responses to the commands are sent in the next valid CS_D.

The table below summarizes the MISO register mode response of various events and MOSI messages. After POR event, RESETB negated, and loss of GND, the L9659 sends 0x0000 in MISO for the first SPI transmission.

The MISO response shown here is the one received in the next valid SPI transmission after each event or MOSI write.

Table 14. MISO responses to various events

| Event/MOSI message | MISO response |
|---|---------------|
| MOSI Parity error or unrecognized command | 0xD000 |
| MOSI transmission - Incorrect number of clocks/bits | 0xD003 |
| Incorrect firing sequence received (Firing Command without a valid Arm Command) | 0xD005 |
| Error due to message not allowed during deployment | 0xD009 |
| POR | 0x0000 |
| RESETB | 0x0000 |
| LOSS OF gnd | 0x0000 |
| RIREF out of range | 0x0000 |
| MOSI Write Soft Reset: \$AA | 0x1X02 |
| MOSI Write Soft Reset: \$55 (after \$AA) | 0x2003 |

Note: X in software reset response interpreted as follows: D11=1;D10=0;D9:D8=CL bits

The SPI fault responses (0xD000 or 0xD003) indicate a fault in the last MOSI transmission. The L9659 uses the parity bit to determine the integrity of the MOSI command transmission.

3.4.5.1 Squib SPI commands

The following are the modes that are supported by the squib L9659 using SPI.

- Configuration mode
- Deployment mode
- Diagnostic mode
- Monitor mode

The table below is a summary of the modes and the functions that are achieved by sending the particular MOSI command. The following sections will provide a full description of bit settings for each mode. All commands and responses use D13 to achieve odd parity.

Table 15. Command description summary

| Command/mode | Description | Mode bits | | | | | | | | |
|--|--|-----------|-----|-----|-----|-----|-----|-----|-----|-----------|
| | | D15 | D14 | D13 | D12 | D11 | D10 | D09 | D08 | D07 - D00 |
| Configuration commands | | | | | | | | | | |
| Config. Mode 1 | Current limit programming and software reset | 0 | 0 | P | - | - | 0 | - | - | - |
| Config. Mode 2 | FEN latch time Programming | 0 | 0 | P | - | - | 1 | - | - | - |
| Deployment commands | | | | | | | | | | |
| Deployment Mode 1 | Arming Command | 0 | 1 | P | 1 | 1 | 0 | 0 | 1 | - |
| Deployment Mode 2 | Firing Command | 0 | 1 | P | 0 | 0 | 0 | 0 | 0 | - |
| Diagnostic commands | | | | | | | | | | |
| Diagnostic Mode 1 | Disable Diagnostic | 1 | 0 | P | - | 0 | 0 | 0 | - | - |
| Diagnostic Mode 2 | Short to battery & ground diagnostics Short between loop diagnostics | 1 | 0 | P | - | 0 | 0 | 1 | - | - |
| Diagnostic Mode 3 | VRESx voltage diagnostics | 1 | 0 | P | - | 0 | 1 | 0 | - | - |
| Diagnostic Mode 4 | High Side Safing diagnostics | 1 | 0 | P | - | 0 | 1 | 1 | - | - |
| Diagnostic Mode 5 | Squib Resistance Diagnostics | 1 | 0 | P | - | 1 | 0 | 0 | - | - |
| Diagnostic Mode 6 | High Squib Resistance Diagnostics | 1 | 0 | P | - | 1 | 0 | 1 | - | - |
| Diagnostic Mode 7 | LS driver diagnostics | 1 | 0 | P | - | 1 | 1 | 0 | - | - |
| Diagnostic Mode 8 | HS driver diagnostics | 1 | 0 | P | - | 1 | 1 | 1 | - | - |
| Monitor commands | | | | | | | | | | |
| Monitor Mode 1 | Deployment status | 1 | 1 | P | - | 0 | 0 | - | - | - |
| Monitor Mode 2 | Channel current limit measurement information | 1 | 1 | P | - | 0 | 1 | - | - | - |
| Monitor Mode 3 | FENx function status and active current limit status | 1 | 1 | P | - | 1 | 0 | - | - | - |
| Monitor Mode 4 | Revision and L9659 ID | 1 | 1 | P | - | 1 | 1 | - | - | - |
| P = Parity bit – all commands and responses will use this bit to achieve odd parity | | | | | | | | | | |

The squib circuits can be reset over when sending the appropriate configuration commands via SPI.

Configuration commands

Configuration mode 1

Configuration mode 1 main functions are as follows:

- Set Deployment current for all channels. All channels will be either set to 1.2A/2ms, 1.5A/2ms (Maximum VRESx Voltage limited to 25V) 1.75A/1ms or 1.75A/0.65ms
- Perform a software reset

The SPI message definition for MOSI commands and MISO responses in this mode are defined below.

| | | | | | | | | | | | | | | | | |
|---|-----|-----|-----|-----|-----|-------------|------------------------------|----|----|----|----|----|----|----|------------|--|
| MSB | | | | | | | | | | | | | | | LSB | |
| D15 | D14 | D13 | D12 | D11 | D10 | D9 | D8 | D7 | D6 | D5 | D4 | D3 | D2 | D1 | D0 | |
| MOSI Command for configuration Mode 1 | | | | | | | | | | | | | | | | |
| 0 | 0 | P | R/W | SWR | 0 | CL Set bits | Software Reset Sequence bits | | | | | | | | | |
| MISO Response for configuration Mode 1 (Except for Soft Reset/D11=1 and appropriate pattern) | | | | | | | | | | | | | | | | |
| 0 | 0 | P | R/W | SWR | 0 | CL Set bits | 0 | 0 | 0 | 0 | 0 | 0 | 0 | 1 | 0 | |

Table 16. Configuration mode 1

| Bit | MOSI command | | MISO response |
|---------|--------------|---|-----------------------------------|
| | State | Description | |
| D15 | 0 | Mode bits | See above |
| D14 | 0 | | See above |
| D13 | | Odd Parity – Includes all 16 bits | Odd Parity – Includes all 16 bits |
| D12 | 0 | Read (default) - When D12='0' bits D11 to D0 are ignored | R/W bit |
| | 1 | Write – Allows Soft reset and deployment programming | |
| D11 | 0 | Sets Deployment Condition for ALL channels - When D11='0' bits D7 to D0 are ignored | See above |
| | 1 | Soft Reset Sequence – bits D8 and D9 are ignored | |
| D10 | 0 | | See above |
| D9 | | Sets Deployment Conditions | Internal Stored Value CL bits |
| D8 | | 00 = 1.2A/2ms (Default) 01 = 1.5A/2ms 10 = 1.75A/0.65ms 11 = 1.75A/1ms | - |
| D7 – D2 | | | See above |
| D1 | | Software Reset-sequence | see above |
| D0 | | | See above |

Bit [D9:D8] Bits used to set the firing current/time for all channels. The default state is '00' (1.2A/2ms min.)

Bits [D7:D0] The soft reset for the L9659, which includes deployment driver/diagnostics, is achieved by writing 0xAA and 0x55 within two

subsequent 16-bit SPI transmissions. If the sequence is broken, the processor will be required to re-transmit the sequence. The L9659 will not reset if the sequence is not completed within two subsequent 16-bit SPI transmissions. When soft reset command is received, the L9659 reset its deployment driver's internal logic and timers, including all internal registers. The effects of a soft reset is the same as a of POR event, except MISO response.

Bit [D1] First response after POR (or equivalent) the PU bit is set to '0'. All responses following the bit is set to '1'.

Bit [D0] Bit D0 used to report the soft reset sequence status. If valid soft reset sequences are received, bit D0 is set to '1.' Otherwise, bit D0 is set to '0.' When L9659 receives valid soft reset sequences, it will send a MISO configuration mode response containing 0x2003 in the next SPI transmission.

Configuration mode 2

Configuration mode 2 main function is as follows:

- Set the latch time for FENx input

The SPI message definition for MOSI commands and MISO responses in this mode are defined below.

| MSB | | | | | | | | | | | | | | | LSB |
|---|-----|-----|-----|-----|-----|------------|----|----|----|----|----|----|----|----|-----|
| D15 | D14 | D13 | D12 | D11 | D10 | D9 | D8 | D7 | D6 | D5 | D4 | D3 | D2 | D1 | D0 |
| MOSI Command for configuration mode 2 | | | | | | | | | | | | | | | |
| 0 | 0 | P | R/W | 0 | 1 | Latch bits | 0 | 0 | 0 | 0 | 0 | 0 | 0 | 0 | 0 |
| MISO Response for configuration mode 2 | | | | | | | | | | | | | | | |
| 0 | 0 | P | R/W | 0 | 1 | Latch bits | 0 | 0 | 0 | 0 | 0 | 0 | 0 | 0 | 0 |

Table 17. Configuration mode 2

| Bit | MOSI command | | MISO response |
|-----|--------------|--|-----------------------------------|
| | State | Description | |
| D15 | 0 | Mode bits | See above |
| D14 | 0 | | See above |
| D13 | | Odd Parity – Includes all 16 bits | Odd Parity – Includes all 16 bits |
| D12 | 0 | Read (default) - When D12='0' bits D11 to D0 are ignored | R/W bit |
| | 1 | Write – FEN latch programming | - |
| D11 | 0 | - | - |
| D10 | 1 | - | - |

Table 17. Configuration mode 2

| Bit | MOSI command | | MISO response |
|---------|--------------|--|---------------|
| | State | Description | |
| D9 | - | FEN latch time | |
| D8 | | 00 = 0ms (default) 01 = 128ms 10 = 256ms 11 = 512ms | |
| D7 – D0 | 0 | - | See above |

Bits [D9:D8] Bits are used to set the period of the FEN latch timer. The L9659 has 4 independent timers. A valid FENx input will start the pulse stretch timer. These bits will set the timer duration. These values default to '00' after a POR event.

Deployment commands

The deployment mode is used to activate the drivers. Two consecutive commands are required to activate the drivers. Any combination of channels can be fired as long as the prerequisite conditions are met as indicated in the previous section.

The SPI message definition for MOSI commands and MISO responses in Deployment Mode are defined below.

| MSB | | | | | | | | | | | | | | | LSB |
|--|-----|-----|-----|-----|-----|----|----|----|----|----|----|--|----|----|-----|
| D15 | D14 | D13 | D12 | D11 | D10 | D9 | D8 | D7 | D6 | D5 | D4 | D3 | D2 | D1 | D0 |
| MOSI Command for Deployment Mode 1 | | | | | | | | | | | | | | | |
| 0 | 1 | P | 1 | 1 | 0 | 0 | 1 | 0 | 0 | 0 | 0 | Arming Channel Select | | | |
| MISO Response for Deployment Mode 1 | | | | | | | | | | | | | | | |
| 0 | 1 | P | 1 | 1 | 0 | 0 | 1 | 0 | 0 | 0 | 0 | Armed Channels | | | |
| MOSI Command for Deployment Mode 2 | | | | | | | | | | | | | | | |
| 0 | 1 | P | 0 | 0 | 0 | 0 | 0 | 0 | 0 | 0 | 0 | Firing Channel Select | | | |
| MISO Response for Deployment Mode 2 | | | | | | | | | | | | | | | |
| 0 | 1 | P | 0 | 0 | 0 | 0 | 0 | 0 | 0 | 0 | 0 | Channels activated or channels waiting for FEN input | | | |

Table 18. Deployment mode 1 bit definition

| Bit | MOSI command | | MISO response |
|----------|--------------|-----------------------------------|-----------------------------------|
| | State | Description | |
| D15 | 0 | See above | |
| D14 | 1 | See above | |
| D13 | - | Odd Parity – Includes all 16 bits | Odd Parity – Includes all 16 bits |
| D12 – D8 | - | Arm pattern | See above |

Table 18. Deployment mode 1 bit definition (continued)

| Bit | MOSI command | | MISO response |
|-----|--------------|--------------------------|-------------------------------|
| | State | Description | |
| D7 | 0 | Channel 7 Idle (default) | Internal Stored Value Arm bit |
| | 1 | Arm Channel 7 | |
| D6 | 0 | Channel 6 Idle (default) | Internal Stored Value Arm bit |
| | 1 | Arm Channel 6 | |
| D5 | 0 | Channel 5 Idle (default) | Internal Stored Value Arm bit |
| | 1 | Arm Channel 7 | |
| D4 | 0 | Channel 4 Idle (default) | Internal Stored Value Arm bit |
| | 1 | Arm Channel 4 | |
| D3 | 0 | Channel 3 Idle (default) | Internal Stored Value Arm bit |
| | 1 | Arm Channel 3 | |
| D2 | 0 | Channel 2 Idle (default) | Internal Stored Value Arm bit |
| | 1 | Arm Channel 2 | |
| D1 | 0 | Channel 1 Idle (default) | Internal Stored Value Arm bit |
| | 1 | Arm Channel 1 | |
| D0 | 0 | Channel 0 Idle (default) | Internal Stored Value Arm bit |
| | 1 | Arm Channel 0 | |

Table 19. Deployment mode 2 bit definition

| Bit | MOSI command | | MISO response |
|--------|--------------|-----------------------------------|------------------------|
| | State | Description | |
| D15 | 0 | Mode bits | See above |
| D14 | 1 | - | See above |
| D13 | - | Odd Parity – Includes all 16 bits | See above |
| D12–D8 | - | Fire pattern | See above |
| D7 | 0 | Channel 7 Idle (default) | Internal Deploy Status |
| | 1 | Deploy Channel 7 | |
| D6 | 0 | Channel 6 Idle (default) | Internal Deploy Status |
| | 1 | Deploy Channel 6 | |
| D5 | 0 | Channel 5 Idle (default) | Internal Deploy Status |
| | 1 | Deploy Channel 5 | |
| D4 | 0 | Channel 4 Idle (default) | Internal Deploy Status |
| | 1 | Deploy Channel 4 | |
| D3 | 0 | Channel 3 Idle (default) | Internal Deploy Status |
| | 1 | Deploy Channel 3 | |

Table 19. Deployment mode 2 bit definition

| Bit | MOSI command | | MISO response |
|-----|--------------|--------------------------|------------------------|
| | State | Description | |
| D2 | 0 | Channel 2 Idle (default) | Internal Deploy Status |
| | 1 | Deploy Channel 2 | |
| D1 | 0 | Channel 1 Idle (default) | Internal Deploy Status |
| | 1 | Deploy Channel 1 | |
| D0 | 0 | Channel 0 Idle (default) | Internal Deploy Status |
| | 1 | Deploy Channel 0 | |

The Deploy Status becomes '1' when there is a valid fire sequence. Once active it will become '0' when the time out has expired waiting FEN activation or when squib driver has turned off for fire completion. The same information is available when receiving a response from Monitor Mode 1.

For the drivers to be fire capable the command mode 1 (Arming) must be sent followed by command mode 2 (Firing). With this sequence valid and FEN active then firing will begin. A break in the sequence will require the process to be restarted. All other bit patterns for D12-D8 will be ignored and the L9659 will respond with \$D005.

To begin a deployment 2 consecutive commands need to be sent along with the FEN active (external or internal latch). An example of a firing sequence for channel 0 would be as follows

FENx active or inactive

TX – 0x5901 – ARM Channel 0

RX – Based on previous command

TX – 0x5901 – ARM Channel 0

RX – 0x5901

TX – 0x5901 – ARM Channel 0

RX – 0x5901

TX – 0x6001 – Firing on Channel 0 is started on if FEN is active

RX – 0x5901

TX – 0x6001 – Command ignored – sequence is not allowed

RX – 0x6001

TX – 0x6001 – Command ignored

RX – 0xD005

Alternatively, if the sequence is broken the response will be as in the following example

FENx active

TX – 0x5901 – ARM Channel 0

RX – Based on previous command

TX – 0x2000 – Read of Register Mode 1

RX – 0x5901

TX – 0x6001 – Command ignored – sequence is not allowed

RX – contents of register

TX – 0x6001 – Command ignored – sequence is not allowed
RX – 0xD005

If, for example, channel 0 and 1 bits are set in the Arm command and channel 0 and 7 bits are set in the fire command then the result will be the drivers on channel 0 will be activated (assuming FEN function is active) and there will be no effect on channel 7.

During a deployment, any commands directed to the channel that are in deployment are ignored and the response shall be 0xD009.

Diagnostic commands

Diagnostic Mode

Diagnostic mode main functions are as follows:

- Squib short to battery/ground diagnostics
- Loop to loop diagnostics
- Normal Squib Resistance Diagnostics
- High Squib Resistance Diagnostics
- High side safing diagnostics
- VRESx measurement
- LS and HS FET Test

The SPI message definition for MOSI commands and MISO responses in Diagnostic Mode are defined below.

Write commands definition

| MSB | | | | | | | | | | | | | | | LSB | |
|--|-----|-----|-----|----------------------|-----|----|------|------|----|-----|---------|-----|-------------------|----|-----|--|
| D15 | D14 | D13 | D12 | D11 | D10 | D9 | D8 | D7 | D6 | D5 | D4 | D3 | D2 | D1 | D0 | |
| MOSI Command for Diagnostic Mode Execution | | | | | | | | | | | | | | | | |
| 1 | 0 | P | 1 | Diag. Selection bits | | | 0 | 0 | 0 | SQP | IPD_DIS | AMC | Channel selection | | | |
| MISO Response for Diagnostic Mode, Stop Diagnostic Selection (MOSI D11:D9=000) Diagnostic Mode 1 | | | | | | | | | | | | | | | | |
| 1 | 0 | P | 1 | 0 | 0 | 0 | 0 | 0 | 0 | 0 | IPD_DIS | 0 | 000 | | | |
| MISO Response for Short to Battery/Ground Selection (MOSI D11:D9=001) Diagnostic Mode 2 | | | | | | | | | | | | | | | | |
| 1 | 0 | P | 1 | 0 | 0 | 1 | STB | STG | 0 | SQP | IPD_DIS | 0 | Channel selection | | | |
| MISO Response for Diagnostic Mode, Vresx Selection (MOSI D11:D9=010) Diagnostic Mode 3 | | | | | | | | | | | | | | | | |
| 1 | 0 | P | 1 | 0 | 1 | 0 | VR1 | VR0 | 0 | 0 | IPD_DIS | 0 | Channel selection | | | |
| MISO Response for Diagnostic Mode, High Side Safing Selection (MOSI D11:D9=011) Diagnostic Mode 4 | | | | | | | | | | | | | | | | |
| 1 | 0 | P | 1 | 0 | 1 | 1 | HSS1 | HSS0 | 0 | 0 | IPD_DIS | 0 | Channel selection | | | |
| MISO Response for Diagnostic Mode, Squib Resistance Selection (MOSI D11:D9=100) Diagnostic Mode 5 | | | | | | | | | | | | | | | | |
| 1 | 0 | P | 1 | 1 | 0 | 0 | 0 | 0 | 0 | 0 | IPD_DIS | AMC | Channel selection | | | |
| MISO Response for Diagnostic Mode, High Squib Resistance Selection (MOSI D11:D9=101) Diag. Mode 6 | | | | | | | | | | | | | | | | |
| 1 | 0 | P | 1 | 1 | 0 | 1 | HSR | 0 | 0 | 0 | IPD_DIS | 0 | Channel selection | | | |
| MISO Response for Diagnostic Mode, Low Side FET Test Selection (MOSI D11:D9=110) Diagnostic Mode 7 | | | | | | | | | | | | | | | | |
| 1 | 0 | P | 1 | 1 | 1 | 0 | STB | STG | FP | FT | IPD_DIS | 0 | Channel selection | | | |
| MISO Response for Diagnostic Mode, High Side FET Test Selection (MOSI D11:D9=111) Diagnostic Mode 8 | | | | | | | | | | | | | | | | |
| 1 | 0 | P | 1 | 1 | 1 | 1 | STB | STG | FP | FT | IPD_DIS | 0 | Channel selection | | | |

Read commands definition

| MSB | | | | | | | | | | | | | | | LSB | |
|--|-----|-----|-----|-------------------------------------|-----|----|----|----|----|----|---------|----|----------------------------------|----|-----|--|
| D15 | D14 | D13 | D12 | D11 | D10 | D9 | D8 | D7 | D6 | D5 | D4 | D3 | D2 | D1 | D0 | |
| MOSI Command for Diagnostic Mode, READ command | | | | | | | | | | | | | | | | |
| 1 | 0 | P | 0 | 0 | 0 | 0 | 1 | 1 | 1 | 1 | 0 | 0 | 000 | | | |
| MISO Response for Diagnostic Mode, READ command | | | | | | | | | | | | | | | | |
| 1 | 0 | P | 0 | Diag. Selection bits internal state | | | X | X | X | X | IPD_DIS | X | Channel Selection Internal State | | | |

Bits D13 Parity bit. Command and response will use odd parity

Bits D12 R/W
 1 = Write (execute command)
 0 = Read

For bits D11:D09 the following table shall be used for diagnostic selection.

Table 20. Diagnostic selection

| Diagnostic | Bits | | | Current source active | Comparator or amplifier |
|---|------|-----|----|-----------------------|-------------------------|
| | D11 | D10 | D9 | | |
| Stop Diagnostic | 0 | 0 | 0 | NO | NO |
| Short to Battery/Ground and short between loops | 0 | 0 | 1 | Y (VMRC) | Y (Comp ISTB/ISTG) |
| VRESx Diagnostic | 0 | 1 | 0 | N | Y (Comp VRESx) |
| High Side Safing Diagnostics | 0 | 1 | 1 | Y (IHSS) | Y (Comp HSS) |
| Squib Resistance Diagnostics | 1 | 0 | 0 | Y (ISRC/ISINK) | Y (Ampli) |
| High Squib Resistance Diagnostics | 1 | 0 | 1 | Y (VMRC/ISINK) | Y (Comp IHR) |
| LS FET test | 1 | 1 | 0 | Y (VMRC) | Y (Comp ISTB/ISTG) |
| HS FET test | 1 | 1 | 1 | Y (VMRC) | Y (Comp ISTB/ISTG) |

Bits D8:D7 The definition of the response bits will change as follows based on diagnostic select

STB/STG bit Definition with MOSI D11:D9=001 (Leakage Test)

- STB bit Bit used for indicating leakage to battery.
 - 0 = No leakage to battery
 - 1 = Short to battery / HS Driver test pass
- STG bit Bit used for indicating leakage to ground.
 - 0 = No leakage to battery
 - 1 = Short to ground / LS Driver test pass

STB/STG bit Definition with MOSI D11:D9=110 (LS FET)

STB, STG bits see table below

Table 21. Diagnostic mode LS FET selection

| Condition | STB | STG |
|--|-----|-----|
| Test in Process (FT=1); Fault present prior to run test (FP=1); or LS FET/GNDx open fault (FP=0,FT=0). Only Valid if test is in process or inactive. | 0 | 0 |
| Short to battery occurred during test. | 1 | 0 |
| Test Pass if leakage diagnostics did not indicate a short to Gnd. | 0 | 1 |

STB/STG bit definition with MOSI D11:D9 =111 (HS FET)

STB, STG bits see table below

Table 22. Diagnostic mode HS FET selection

| Condition | STB | STG |
|---|-----|-----|
| Test in Process (FT=1); Fault present prior to run test (FP=1); or HS FET/VRESx open fault (FP=0,FT=0). Only Valid if test is in process or inactive. | 0 | 0 |
| Test Pass if leakage diagnostics did not indicate a short to battery. | 1 | 0 |
| Short to ground occurred during test. | 0 | 1 |

HSS1:HSS0 bit definition with MOSI D11:D9=011 (High side safing)

HSS1:HSS0 bits see table below

Table 23. Diagnostic mode HSS selection

| Condition | HSS1 | HSS0 |
|---|------|------|
| $(V_{SDIAG}-V_{RESx}) < V_{HSSSHORT_th}$ | 0 | 0 |
| $V_{HSSSHORT_th} < (V_{SDIAG}-V_{RESx}) < V_{HSSOPEN_th}$ | 0 | 1 |
| $V_{HSSOPEN_th} < (V_{SDIAG}-V_{RESx})$ | 1 | 1 |

VR1:VR0 bit definition with MOSI D11:D9=010 (VRESx supply voltage)

VR1:VR0 bits see table below

Table 24. Diagnostic mode VRESx selection

| Condition | VR1 | VR0 |
|--|-----|-----|
| $V_{RESx} < V_{VRESXLO_th}$ | 0 | 0 |
| $V_{VRESXLO_th} < V_{RESx} < V_{VRESXHI_th}$ | 0 | 1 |
| $V_{VRESXHI_th} < V_{RESx}$ | 1 | 1 |

HSR Bit Definition with MOSI D11:D9=101 (High Squib Resistance)

| | |
|---------|--|
| HSR bit | Bit used for indicating a high squib resistance. |
| | 0 = Squib Resistance below R_{SQHIZ} |
| | 1 = Squib Resistance above R_{SQHIZ} |
| Bits D6 | FP Fault present prior to running LS FET or HS FET test (diagnostics aborted) 0 = Normal 1 = Test not run - Fault present (FEN in incorrect state, short to battery or ground) |
| Bits D5 | Bit definition based on diagnostic selection. FT bit Read Only - Used for LS FET or HS FET diagnostics and is the status of the FET timer 0 = FET timer not active 1 = FET timer active |

SQP bit: Squib Pin to be tested during short to battery/ground diagnostics
 0 = SQBLx pin test
 1 = SQBHx pin test

Bits D4 Used to disable IPD on all channels
 0 = IPD active as indicated;
 – Active for all channels except the one under test when running Short to Battery/Ground and short between loops Diagnostics and LS/HS FET test
 – Active for all channels when running Stop Diagnostic, Resistance Diagnostics, High Squib Resistance Diagnostics, HSS Diagnostic and VRESx Diagnostics
 1 = IPD disabled on all channels

Bits D3 AMC Bit Bit used for resistance measurement amplifier calibration. Only valid when squib resistance diagnostics is selected, otherwise this it will be ignored and a 0 will be reported in the response
 0 = No calibration (Normal squib resistance measurements)
 1 = Calibration

For bits D2:D0 The following table shall be used for channel selection.

Table 25. Channel selection

| Channel | Bit D2 | Bit D1 | Bit D0 |
|---------|--------|--------|--------|
| 0 | 0 | 0 | 0 |
| 1 | 0 | 0 | 1 |
| 2 | 0 | 1 | 0 |
| 3 | 0 | 1 | 1 |
| 4 | 1 | 0 | 0 |
| 5 | 1 | 0 | 1 |
| 6 | 1 | 1 | 0 |
| 7 | 1 | 1 | 1 |

All other combinations for MOSI bits D2:D0 will produce an error response of 0xD000.

Note: Except for short to battery /ground diagnostics and loop to loop test the state of IPD (D4) will not affect the test.

Monitor commands

Monitor Mode 1

Monitor mode main information:

- Deployment status

The SPI message definition for MOSI commands and MISO responses in Monitor Mode 1 are defined below.

| MSB | | | | | | | | | | | | | | LSB | |
|---|-----|-----|-----|-----|-----|----|----|----------------------------------|----|----|----|----|----|-----|----|
| D15 | D14 | D13 | D12 | D11 | D10 | D9 | D8 | D7 | D6 | D5 | D4 | D3 | D2 | D1 | D0 |
| MOSI Command for Monitor Mode 1 | | | | | | | | | | | | | | | |
| 1 | 1 | P | 0 | 0 | 0 | 0 | DS | Channel Selection Status Request | | | | | | | |
| MISO Response for Monitor Mode 1 | | | | | | | | | | | | | | | |
| 1 | 1 | P | 0 | 0 | 0 | 0 | DS | Channel Status | | | | | | | |

Table 26. MOSI diagnostic mode 1 bit definition

| Bit | MOSI Command | | MISO Response |
|-----|--------------|--|--|
| | State | Description | |
| D15 | 1 | Mode bits | |
| D14 | 1 | | |
| D13 | | Odd Parity – Includes all 16 bits | Odd Parity – Includes all 16 bits |
| D12 | 0 | - | See above for state |
| D11 | 0 | Monitor Mode selection bits | See above for state |
| D10 | 0 | Monitor Mode selection bits | See above for state |
| D9 | 0 | - | See above for state |
| D8 | 0 | Report Deploy Success Flag (default) | Internal state of report setting |
| | 1 | Report Deploy Status | |
| D7 | 0 | Keep Deploy Success Flag Channel 7 (default) | Deploy Information for channel based on bit D8 Will Either be DEPLOY_STATUS7 or DEPLOY_SUCCESS7 |
| | 1 | Clear Deploy Success Flag Channel 7 | |
| D6 | 0 | Keep Deploy Success Flag Channel 6 (default) | Deploy Information for channel based on bit D8 Will Either be DEPLOY_STATUS6 or DEPLOY_SUCCESS6 |
| | 1 | Clear Deploy Success Flag Channel 6 | |
| D5 | 0 | Keep Deploy Success Flag Channel 5 (default) | Deploy Information for channel based on bit D8 Will Either be DEPLOY_STATUS5 or DEPLOY_SUCCESS5 |
| | 1 | Clear Deploy Success Flag Channel 5 | |
| D4 | 0 | Keep Deploy Success Flag Channel 4 (default) | Deploy Information for channel based on bit D8 Will Either be DEPLOY_STATUS4 or DEPLOY_SUCCESS4 |
| | 1 | Clear Deploy Success Flag Channel 4 | |
| D3 | 0 | Keep Deploy Success Flag Channel 3 (default) | Deploy Information for channel based on bit D8 Will Either be DEPLOY_STATUS3 or DEPLOY_SUCCESS3 |
| | 1 | Clear Deploy Success Flag Channel 3 | |

Table 26. MOSI diagnostic mode 1 bit definition

| Bit | MOSI Command | | MISO Response |
|-----|--------------|--|---|
| | State | Description | |
| D2 | 0 | Keep Deploy Success Flag Channel 2 (default) | Deploy Information for channel based on bit D8 Will Either be DEPLOY_STATUS2 or DEPLOY_SUCCESS2 |
| | 1 | Clear Deploy Success Flag Channel 2 | |
| D1 | 0 | Keep Deploy Success Flag Channel 1 (default) | Deploy Information for channel based on bit D8 Will Either be DEPLOY_STATUS1 or DEPLOY_SUCCESS1 |
| | 1 | Clear Deploy Success Flag Channel 1 | |
| D0 | 0 | Keep Deploy Success Flag Channel 0 (default) | Deploy Information for channel based on bit D8 Will Either be DEPLOY_STATUS0 or DEPLOY_SUCCESS0 |
| | 1 | Clear Deploy Success Flag Channel 0 | |

The DEPLOY_SUCCESSx flag indicates if the corresponding channel’s drivers were activated and that the activation period has completed. This bit is set when the activation period has expired. The DEPLOY_SUCCESSx flag will be ‘1’ until it is cleared by writing a ‘1’ to the appropriate channel(s) (bits D7-D0).

The DEPLOY_STATUSx bit will become ‘1’ when there is a valid Arm and Fire sequence for the corresponding channel. The DEPLOY_STATUSx bit transitioning from a ‘0’ to a ‘1’ does not depend on the state of the FEN function. It will become ‘0’ when time out has expired. Depending on the state of FEN the DEPLOY_STATUSx flag could be ‘1’ for a minimum of 1x t_{DEPLOY} and a maximum of up to 2 x t_{DEPLOY} (see *Figure 8.*) The Deployment status is captured on the falling edge of CS_D.

Bit D8 is used to select the meaning of bit D7 through bit D0 in the status response message. When this bit is set to ‘1,’ bits D7 through D0 in the status response message will report the state of the DEPLOY_STATUSx flag.

When this bit is ‘0,’ bit D7 through bit D0 in the status response message will report the DEPLOY_SUCCESSx flag. The following table shows the conditions for the DEPLOY_STATUSx flag and the DEPLOY_SUCCESSx flag.

Table 27. DEPLOY_STATUSx flag and the DEPLOY_SUCCESSx flag conditions

| DEPLOY_STATUSx flag | DEPLOY_SUCCESSx flag | Description |
|---------------------|----------------------|--|
| 0 | 0 | No Deployment in process or has been initiated since POR or since last Clear of Success flag |
| 0 | 1 | Deployment has successfully completed |
| 1 | 0 | Deployment in process |
| 1 | 1 | Deployment terminated / LSD shutdown |

Once the Deploy Success Flag is set, it will inhibit the subsequent deployment command until a SPI command to clear this deployment success flag is received. Bits D7 through bit D0 are used to clear/keep the deploy success flag. When these bits are set to ‘1,’ the flag can be cleared. Otherwise, the state of these flags is not affected. **The Success flag must be cleared to allow re-activation of the drivers**

Monitor mode 2

Monitor mode main information:

- Current limit measurement of channels

The SPI message definition for MOSI commands and MISO responses in Monitor Mode 2 are defined below.

| MSB | | | | | | | | | | | | | | LSB | |
|---|-----|-----|-----|-----|-----|------------------------------------|----|----|--------------------------|----|----|----|----|-----|----|
| D15 | D14 | D13 | D12 | D11 | D10 | D9 | D8 | D7 | D6 | D5 | D4 | D3 | D2 | D1 | D0 |
| MOSI Command for Monitor Mode 2 | | | | | | | | | | | | | | | |
| 1 | 1 | P | CLR | 0 | 1 | Current Measurement Channel Select | | | 0 | 0 | 0 | 0 | 0 | 0 | 0 |
| MISO Response for Monitor Mode 2 | | | | | | | | | | | | | | | |
| 1 | 1 | P | 0 | 0 | 1 | Current Measurement Channel | | | Current Measurement Data | | | | | | |

Table 28. MOSI monitor mode 2 Bit definition

| Bit | MOSI command | | MISO response | |
|-------|--------------|--|---------------|---|
| | State | Description | | |
| D15 | 1 | Mode bits | | See above for state |
| D14 | 1 | Mode bits | | See above for state |
| D13 | | Odd parity – Includes all 16 bits | | Odd Parity – Includes all 16 bits |
| D12 | 0 | Keep timer measurements | | See above for state |
| | 1 | Clear “current measurement time” stored on the register of channel selected by D9:D7 | | See above for state |
| D11 | 0 | Monitor mode selection bits | | See above for state |
| D10 | 1 | Monitor mode selection bits | | See above for state |
| D9 | | Channel selected for current measurement See Table 29 | | Internal Stored channel selections bits |
| D8 | | | | |
| D7 | | | | |
| D6:D0 | 0 | - | | Current measurement of selected channel |

Bits [D9:D7]. Used when sending the MOSI command to select the channel to be measured. The MISO response will echo the MOSI command.

Table 29. Current measurement channel selections

| Channel | Bit D9 | Bit D08 | Bit D07 |
|---------|--------|---------|---------|
| 0 | 0 | 0 | 0 |
| 1 | 0 | 0 | 1 |
| 2 | 0 | 1 | 0 |
| 3 | 0 | 1 | 1 |

Table 29. Current measurement channel selections (continued)

| Channel | Bit D9 | Bit D08 | Bit D07 |
|---------|--------|---------|---------|
| 4 | 1 | 0 | 0 |
| 5 | 1 | 0 | 1 |
| 6 | 1 | 1 | 0 |
| 7 | 1 | 1 | 1 |

All other combinations for MOSI bits D9:D7 will produce an error response of 0xD000.

Bits [D6:D0] Current measurement data of selected squib channel. Bit weight is nominally 25µs for a total measurement time 3.175ms.

Monitor mode 3

Monitor mode main information:

- Status of FENx Function - FENx pin OR'd with Internal FENx latch
- Status of current for each channel

The SPI message definition for MOSI commands and MISO responses in Monitor Mode 3 are defined below.

| MSB | | | | | | | | | | | | | | | LSB | |
|---|-----|-----|-----|-----|-----|-----|----------|-----|-----|-----|-----|-----|-----|-----|-----|---|
| D15 | D14 | D13 | D12 | D11 | D10 | D9 | D8 | D7 | D6 | D5 | D4 | D3 | D2 | D1 | D0 | |
| MOSI Command for Monitor Mode 3 | | | | | | | | | | | | | | | | |
| 1 | 1 | P | 0 | 1 | 0 | CFS | 0 | 0 | 0 | 0 | 0 | 0 | 0 | 0 | 0 | 0 |
| MISO Response for Monitor Mode 3 | | | | | | | | | | | | | | | | |
| 1 | 1 | P | 0 | 1 | 0 | CFS | POR STAT | CF7 | CF6 | CF5 | CF4 | CF3 | CF2 | CF1 | CF0 | |

Table 30. MOSI monitor mode 3 bit definition

| Bit | MOSI command | | MISO response | |
|-------|--------------|--|---------------|---|
| | State | Description | State | Description |
| D15 | 1 | Mode Bits | | See above for state |
| D14 | 1 | | | See above for state |
| D13 | - | Odd Parity – Includes all 16 bits | | Odd Parity – Includes all 16 bits |
| D12 | 0 | - | | See above for state |
| D11 | 1 | - | | See above for state |
| D10 | 0 | - | | See above for state |
| D09 | | Status Type 0 = Current limit status 1 = FEN function status | | 0 = current measurement status reported in bit D7:D0 1 = FEN function status reported in D7:D0 |
| D08 | 0 | - | | POR status |
| D7:D0 | 0 | - | | Current measurement status of channels or FEN status as indicated below |

Bit [D8] POR status

0= Reset occurred. Bit cleared when read

1= Normal

With Bit D9=0 CFS

Bit D7:D4 '0000'

Bit D3: 0 = FEN4 input or FEN4 latch timer inactive

1 = FEN4 input or FEN4 latch timer active

Bit D2: 0 = FEN3 input or FEN3 latch timer inactive

1 = FEN3 input or FEN3 latch timer active

Bit D1: 0 = FEN2 input or FEN2 latch timer inactive

1 = FEN2 input or FEN2 latch timer active

Bit D0: 0 = FEN1 input or FEN1 latch timer inactive

1 = FEN1 input or FEN1 latch timer active

Note: The FEN status is the result of the state of the FEN input pin OR'd with the FEN latch timer. The FEN latch timer will remain inactive until a transition of '1' to '0' on the FEN input (assuming the pin was high for a minimum of 16µs). At that time the FEN latch timer will be active and keep the internal FEN signal active based on the programmed time (0ms, 128ms, 256ms or 512ms) for that particular FEN function.

With Bit D9=1 CFS

Bit D7: 0 = Current through channel 7 is below I_{MEAS}

1 = Current through channel 7 is above I_{MEAS}

Bit D6: 0 = Current through channel 6 is below I_{MEAS}

1 = Current through channel 6 is above I_{MEAS}

Bit D5: 0 = Current through channel 5 is below I_{MEAS}

1 = Current through channel 5 is above I_{MEAS}

Bit D4: 0 = Current through channel 4 is below I_{MEAS}

1 = Current through channel 4 is above I_{MEAS}

Bit D3: 0 = Current through channel 3 is below I_{MEAS}

1 = Current through channel 3 is above I_{MEAS}

Bit D2: 0 = Current through channel 2 is below I_{MEAS}

1 = Current through channel 2 is above I_{MEAS}

Bit D1: 0 = Current through channel 1 is below I_{MEAS}

1 = Current through channel 1 is above I_{MEAS}

Bit D0: 0 = Current through channel 0 is below I_{MEAS}

1 = Current through channel 0 is above I_{MEAS}

Note: current status for channel is captured on the falling edge of chip select

Monitor mode 4

Monitor mode main information:

- Revision
- L9659 ID

The SPI message definition for MOSI commands and MISO responses in Monitor Mode 4 are defined below

| | | | | | | | | | | | | | | | | |
|---|-----|-----|-----|-----|-----|-----|-----|-----|-----|----|----|----|----|----|----|------------|
| MSB | | | | | | | | | | | | | | | | LSB |
| D15 | D14 | D13 | D12 | D11 | D10 | D9 | D8 | D7 | D6 | D5 | D4 | D3 | D2 | D1 | D0 | |
| MOSI Command for Monitor Mode 4 | | | | | | | | | | | | | | | | |
| 1 | 1 | P | 0 | 1 | 1 | 0 | 0 | 0 | 0 | 0 | 0 | 0 | 0 | 0 | 0 | |
| MISO Response for Monitor Mode 4 | | | | | | | | | | | | | | | | |
| 1 | 1 | P | 0 | 1 | 1 | ID3 | ID2 | ID1 | ID0 | R5 | R4 | R3 | R2 | R1 | R0 | |

Table 31. MOSI monitor mode 4 bit definition

| Bit | MOSI command | | MISO response |
|-------|--------------|-----------------------------------|-----------------------------------|
| | State | Description | |
| D15 | 1 | Mode Bits | See above for state |
| D14 | 1 | | See above for state |
| D13 | | Odd Parity – Includes all 16 bits | Odd Parity – Includes all 16 bits |
| D12 | 0 | - | See above for state |
| D11 | 1 | Mode selection | See above for state |
| D10 | 1 | Mode selection | See above for state |
| D9-D6 | 0 | - | '0100' is device L9659 |
| D5:D0 | 0 | - | Revision Information |

The MOSI response for the first pass L9659 will be 0xED08

4 Package information

In order to meet environmental requirements, ST offers these devices in different grades of ECOPACK® packages, depending on their level of environmental compliance. ECOPACK® specifications, grade definitions and product status are available at: www.st.com.

ECOPACK® is an ST trademark.

Figure 10. LQFP64 mechanical data and package dimensions.

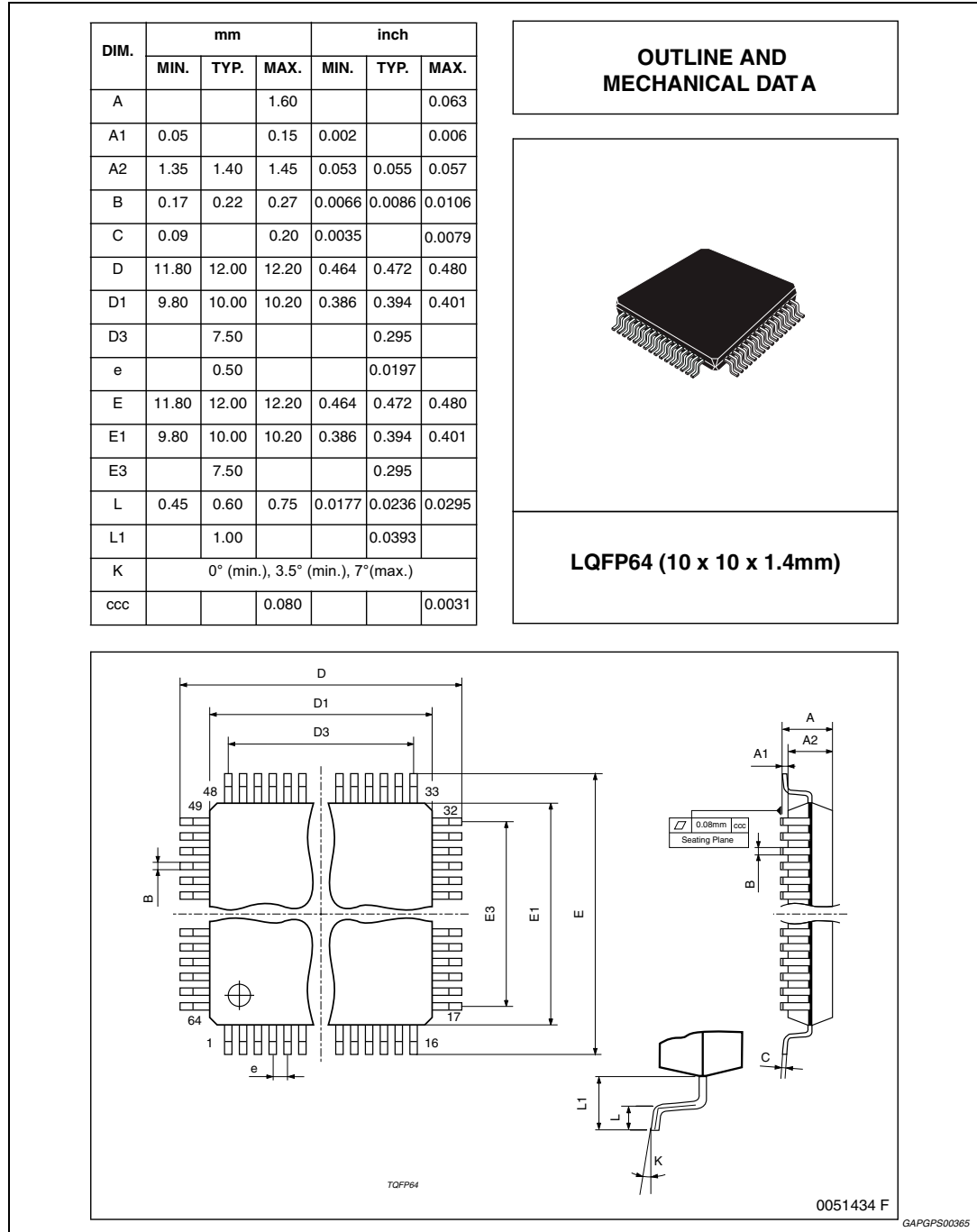

5 Revision history

Table 32. Document revision history

| Date | Revision | Changes |
|-------------|----------|---------------------|
| 26-Jul-2011 | 1 | Initial release. |
| 19-Sep-2013 | 2 | Updated disclaimer. |

Please Read Carefully:

Information in this document is provided solely in connection with ST products. STMicroelectronics NV and its subsidiaries ("ST") reserve the right to make changes, corrections, modifications or improvements, to this document, and the products and services described herein at any time, without notice.

All ST products are sold pursuant to ST's terms and conditions of sale.

Purchasers are solely responsible for the choice, selection and use of the ST products and services described herein, and ST assumes no liability whatsoever relating to the choice, selection or use of the ST products and services described herein.

No license, express or implied, by estoppel or otherwise, to any intellectual property rights is granted under this document. If any part of this document refers to any third party products or services it shall not be deemed a license grant by ST for the use of such third party products or services, or any intellectual property contained therein or considered as a warranty covering the use in any manner whatsoever of such third party products or services or any intellectual property contained therein.

UNLESS OTHERWISE SET FORTH IN ST'S TERMS AND CONDITIONS OF SALE ST DISCLAIMS ANY EXPRESS OR IMPLIED WARRANTY WITH RESPECT TO THE USE AND/OR SALE OF ST PRODUCTS INCLUDING WITHOUT LIMITATION IMPLIED WARRANTIES OF MERCHANTABILITY, FITNESS FOR A PARTICULAR PURPOSE (AND THEIR EQUIVALENTS UNDER THE LAWS OF ANY JURISDICTION), OR INFRINGEMENT OF ANY PATENT, COPYRIGHT OR OTHER INTELLECTUAL PROPERTY RIGHT.

ST PRODUCTS ARE NOT DESIGNED OR AUTHORIZED FOR USE IN: (A) SAFETY CRITICAL APPLICATIONS SUCH AS LIFE SUPPORTING, ACTIVE IMPLANTED DEVICES OR SYSTEMS WITH PRODUCT FUNCTIONAL SAFETY REQUIREMENTS; (B) AERONAUTIC APPLICATIONS; (C) AUTOMOTIVE APPLICATIONS OR ENVIRONMENTS, AND/OR (D) AEROSPACE APPLICATIONS OR ENVIRONMENTS. WHERE ST PRODUCTS ARE NOT DESIGNED FOR SUCH USE, THE PURCHASER SHALL USE PRODUCTS AT PURCHASER'S SOLE RISK, EVEN IF ST HAS BEEN INFORMED IN WRITING OF SUCH USAGE, UNLESS A PRODUCT IS EXPRESSLY DESIGNATED BY ST AS BEING INTENDED FOR "AUTOMOTIVE, AUTOMOTIVE SAFETY OR MEDICAL" INDUSTRY DOMAINS ACCORDING TO ST PRODUCT DESIGN SPECIFICATIONS. PRODUCTS FORMALLY ESCC, QML OR JAN QUALIFIED ARE DEEMED SUITABLE FOR USE IN AEROSPACE BY THE CORRESPONDING GOVERNMENTAL AGENCY.

Resale of ST products with provisions different from the statements and/or technical features set forth in this document shall immediately void any warranty granted by ST for the ST product or service described herein and shall not create or extend in any manner whatsoever, any liability of ST.

ST and the ST logo are trademarks or registered trademarks of ST in various countries.

Information in this document supersedes and replaces all information previously supplied.

The ST logo is a registered trademark of STMicroelectronics. All other names are the property of their respective owners.

© 2013 STMicroelectronics - All rights reserved

STMicroelectronics group of companies

Australia - Belgium - Brazil - Canada - China - Czech Republic - Finland - France - Germany - Hong Kong - India - Israel - Italy - Japan - Malaysia - Malta - Morocco - Philippines - Singapore - Spain - Sweden - Switzerland - United Kingdom - United States of America

www.st.com