

VICOR CONFIDENTIAL  
 THIS DOCUMENT AND THE DATA DISCLOSED HEREIN OR  
 HEREIN IS NOT TO BE REPRODUCED, USED OR  
 DISCLOSED IN WHOLE OR IN PART TO ANYONE WITHOUT  
 THE PERMISSION OF VICOR CORP.

REV.	DESCRIPTION	DATE	APPROVED
2	REVISED PER E080070	SA 01/15/08	REJH
3	REVISED PER E091753	JS 09/29/09	REJH
4	REVISED PER E092276	JS 12/30/09	REJH
5	REVISED PER E120065	VSS 01/20/12	KUK

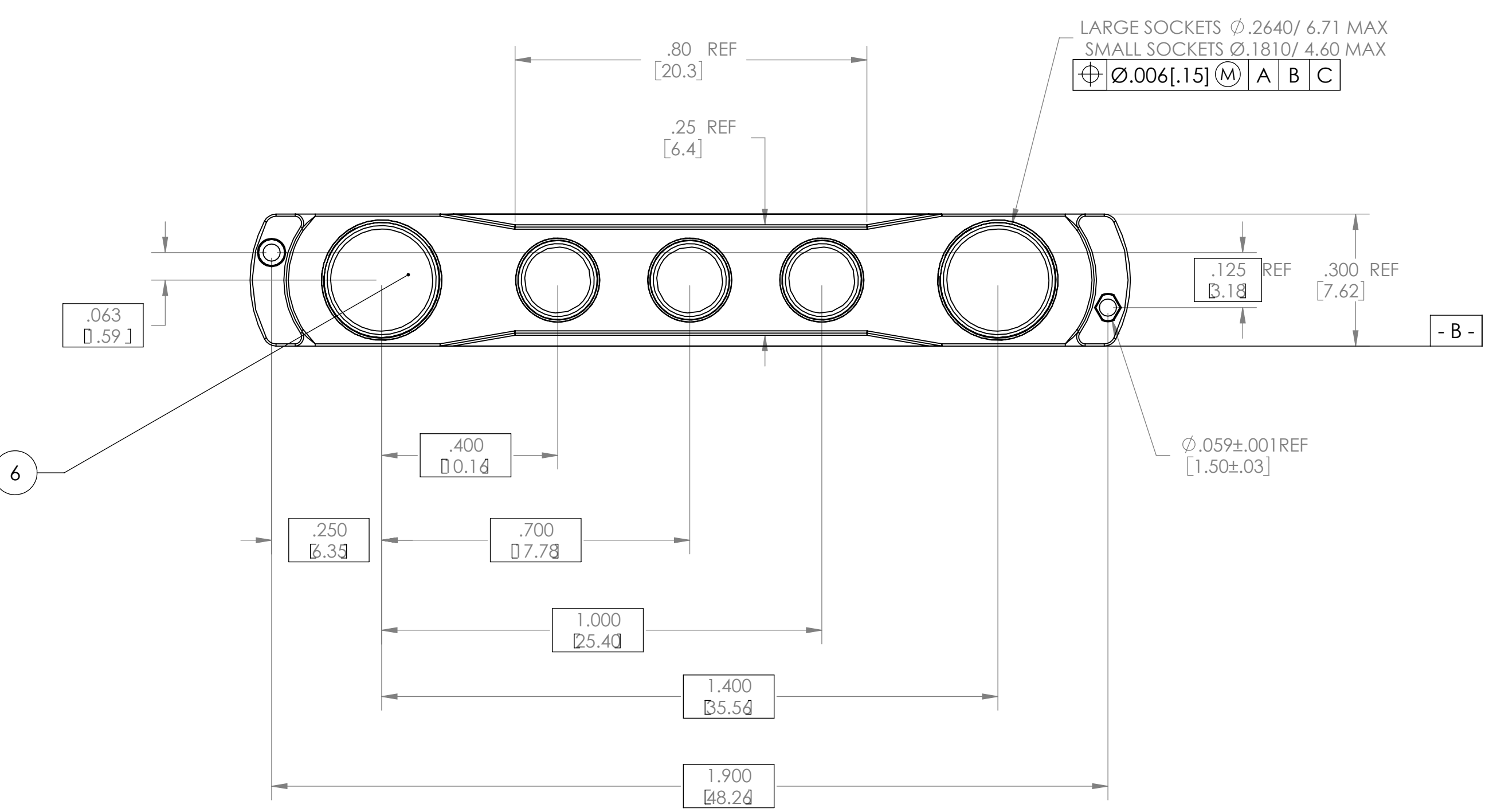
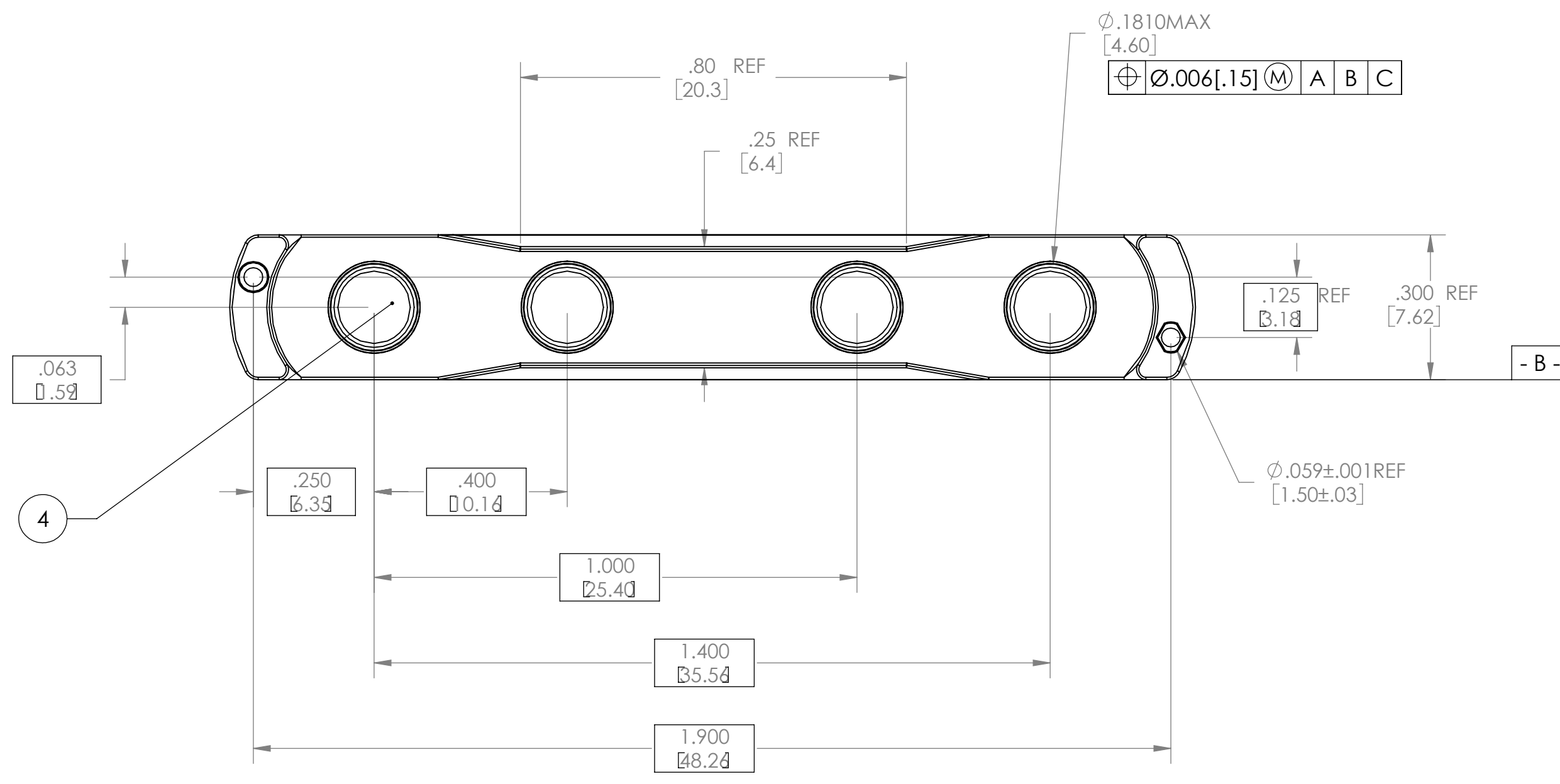
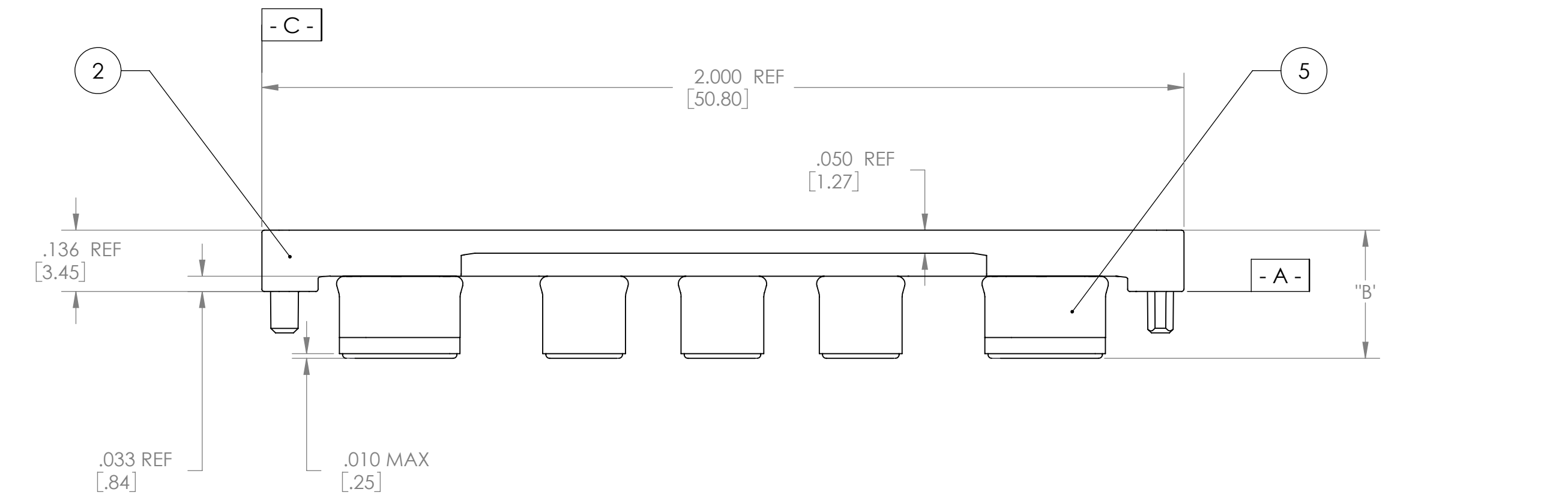
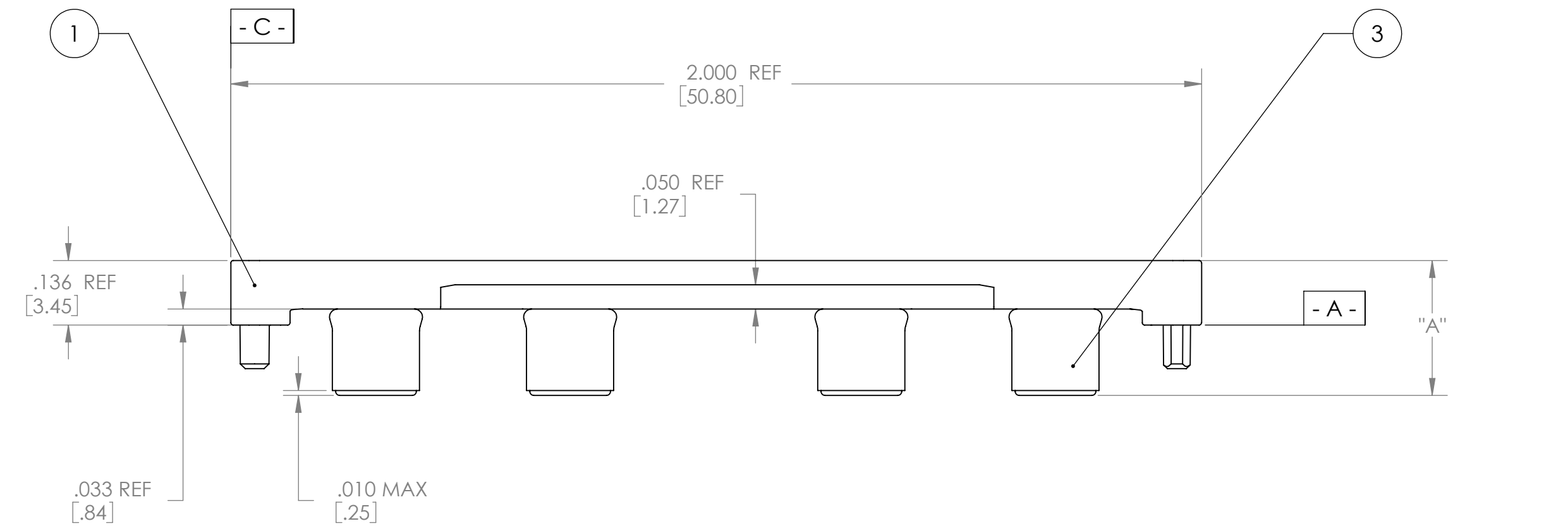
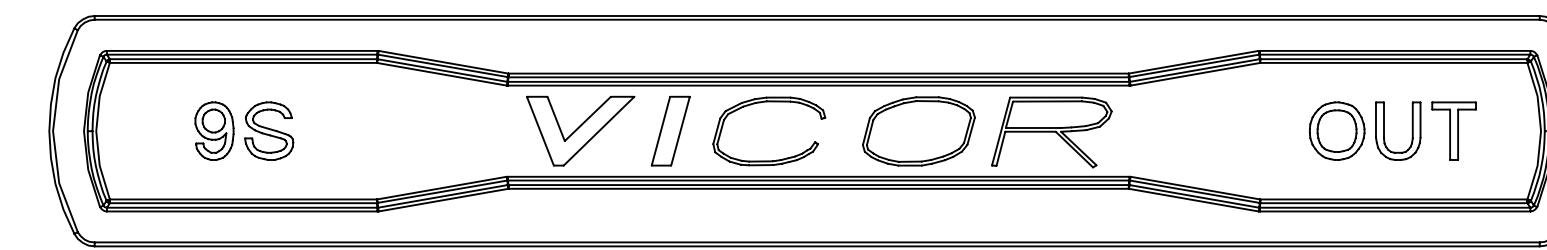
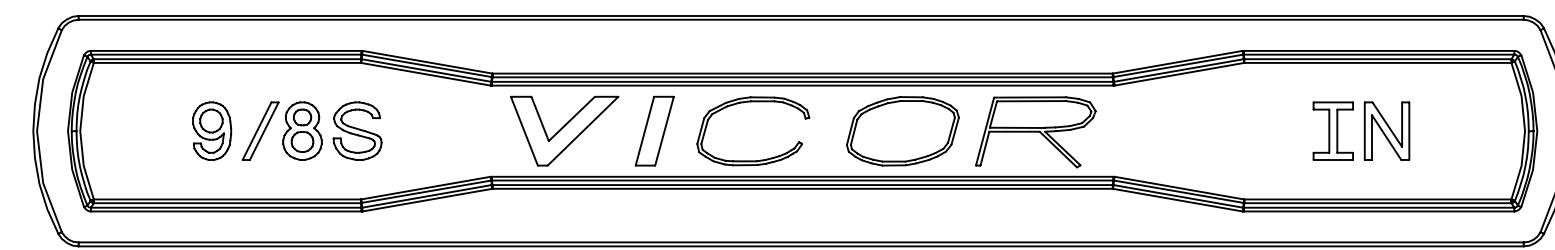

DASH NO.	SOCKET BODY LENGTH INCH/MM	DIM "A" INCH/MM	DIM "B" INCH/MM	INPUT	OUTPUT	KIT #
-01	.100/2.54	.243/6.17	.243/6.17	18374	18382	18362
-02	.135/3.43	.278/7.06	.278/7.06	18375	18383	18363

- NOTE:  
 1. MATERIALS: INMATES: PPS RYTON 7  
 SOCKETS: BE-CU #25, Au PLATED.  
 2. FULLY SEAT SOCKET INTO INMATE HEADER.  
 3. ROHS COMPLIANT PER CST-0001 LATEST REVISION.

DRAWN BY: LAP NGUYEN DATE: 6/99  
 UNLESS OTHERWISE SPECIFIED DIMENSIONS ARE: INCH / (MM)  
 TOLERANCES ARE: DECIMALS ANGLES  
 XXX (X.X) = +0.01 (0.25) ±1°  
 XXXX (X.XX) = ±0.005 (0.127)  
 THIRD ANGLE PROJECTION  
 DO NOT SCALE DRAWING

VICOR  
 DWG, VI-900 INMATE/SOCKET, BIB  
 SCALE 4:1  
 SIZE D CAGE CODE 67131 DWG NO 18483-XX REV 5  
 SHEET 1 OF 1

