

Features

- 5050 with integrated high quality constant current IC and RGBW LED chips.
- Built-in IC, with high precision of constant current and internal RGBW chips spectral processing in advance.
- Single line data transmission (return to zero code).
- Specific Shaping Transmit Technology - number of LED stacked is not restricted.
- Cascading Enhancement Technology - any 2 LED spacing can be up to 10 meters
- Data transfer rate of 800 kbp/s at 30 frames per second.
- RGBW output port PWM control can achieve 256 grey level adjustments.
- Upon powering up, IC performs self-inspection then lights connection on the pin B lamp.
- SA-I Anti-interference patent technology for single line data transmission.
- Built-in power supply reverse connect protection module, reversed power input will not damage the IC.

Description

The IN-PI55QATPRPGBPW-XX is 5.0*5.0*1.6mm RGBW LED with integrated IC. It is a SMD type LED which can be used in various applications.

Applications

- Full color LED string light
- LED full color module
- LED guardrail tube
- LED scene lighting
- LED point light
- LED pixel screen
- LED shaped screen

Package Outline Dimensions & Pin Configuration

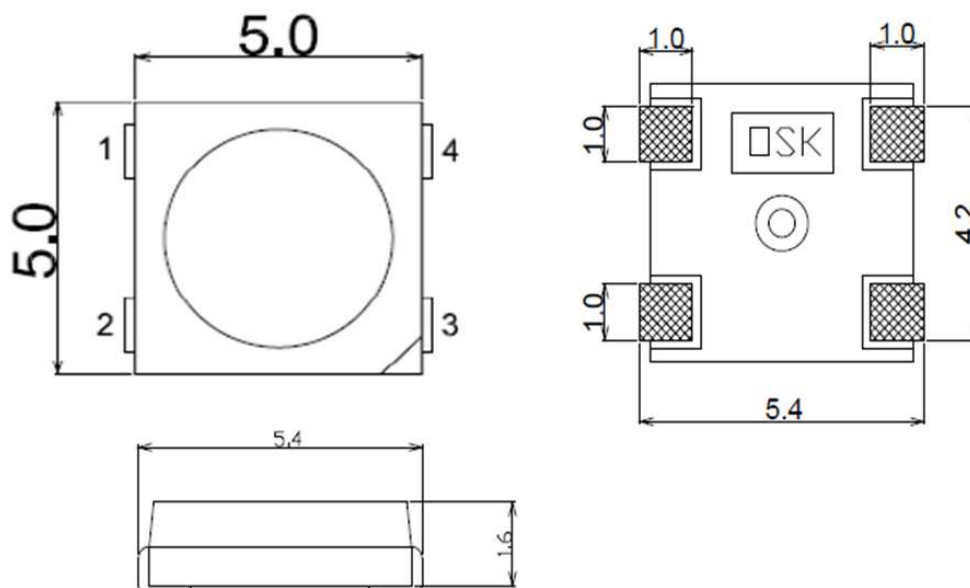

Figure 1. IN-PI55QATPRPGBPW-XX Package Outline Dimensions

Pin Configuration

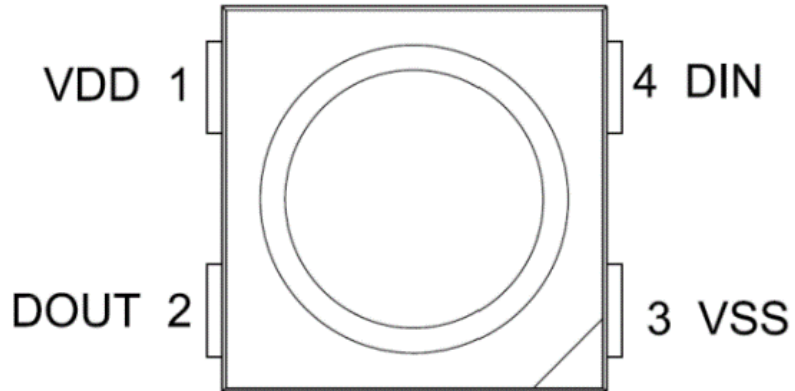

Figure 2. IN- PI55QATPRPGBPW-XX Pin Configuration

Notes:

1. Dimension in millimeter, tolerance is $\pm 0.1\text{mm}$ unless otherwise noted.

Number	Symbol	Function Description
1	VDD	Power supply LED
2	DOUT	Control data signal output
3	VSS	Ground
4	DIN	Control data signal input

Soldering Pad Size

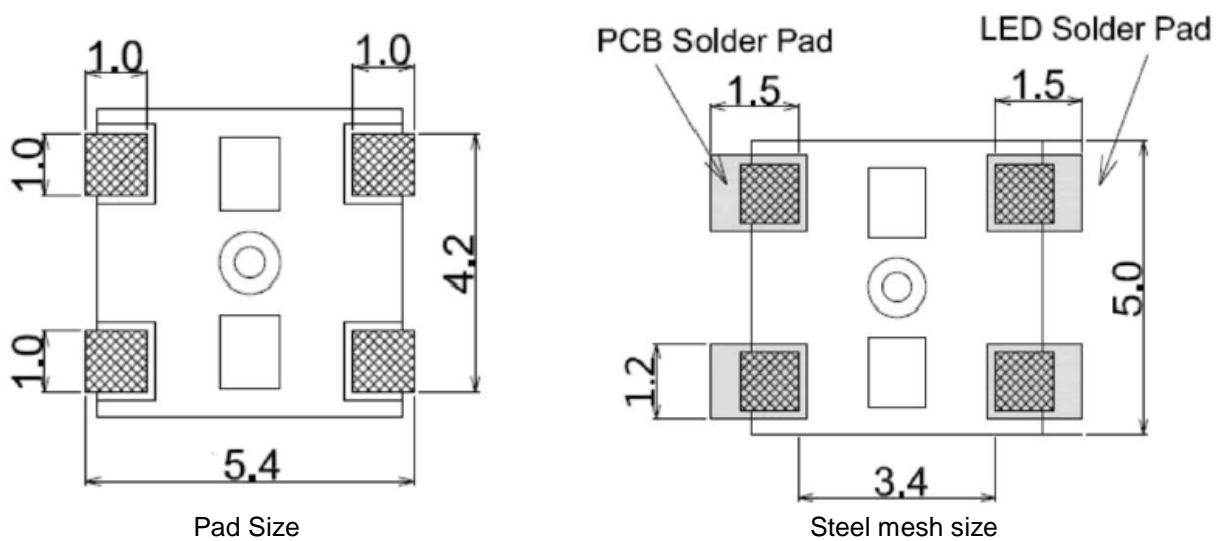

Absolute Maximum Rating ($T_a = 25\text{ }^\circ\text{C}$, $V_{SS}=0V$)

Parameter	Symbol	Range	Unit
Power supply voltage	V_{DD}	+3.5~+5.5	V
Logic input voltage	V_{IN}	-0.5 ~VDD+0.5	V
Working temperature	T_{OPT}	-45 ~ +85	$^\circ\text{C}$
Storage temperature	T_{STG}	-50 ~ +150	$^\circ\text{C}$
ESD pressure(HBM)	V_{ESD}	4K	V
ESD pressure(DM)	V_{ESD}	200	V

LED Characteristics ($T_a = 25^\circ\text{C}$)

Color	12mA	
	Wavelength(nm)	Light Intensity(mcd)
Red	620-630	200-400
Green	515-530	700-1000
Blue	460-470	100-200
Cool White	6000K	1500-2200
Neutral White	4000k	1500-2200
Warm White	3000k	1500-2200

Recommended Operating Ranges (unless otherwise specified, $T_a = -20 \sim +70 \text{ }^\circ\text{C}$, $V_{DD} = 4.5 \sim 5.5\text{V}$, $V_{SS} = 0\text{V}$)

Parameter	Symbol	Min.	Typ.	Max	Unit	Test conditions
Supply voltage	V_{DD}	3.5	5.2	5.5	V	-
R/G/B port pressure	$V_{DS, MAX}$	-	-	26	V	-
DOUT drive capability	I_{DOH}	-	49	-	mA	maximum source current
DOUT drive capability	I_{DOL}	-	-50	-	mA	maximum sink current
The signal input flip threshold	V_{IH}	$0.7 * V_{DD}$	-		V	$V_{DD} = 5.0\text{V}$
The signal input flip threshold	V_{IL}	-	-	$0.3 * V_{DD}$	V	$V_{DD} = 5.0\text{V}$
The frequency of PWM	F_{PWM}	-	1.2	-	KHZ	-
Static power consumption	I_{DD}	-	1	-	mA	-

Switching Characteristics (unless otherwise specified, $T_A=25\text{ }^\circ\text{C}$)

Parameter	Symbol	Min.	Typ.	Max	Unit	Test conditions
The speed of data transmission	f_{DIN}	-	800	-	KHZ	The duty ratio of 67% (data 1)
DOUT transmission delay	T_{PLH}	-	-	500	ns	DIN→DOUT
	T_{PHL}	-	-	500	ns	
I_{OUT} Rise/Drop Time	T_r	-	100	-	ns	VDS=1.5 IOUT=9~18mA
	T_f	-	100	-	ns	

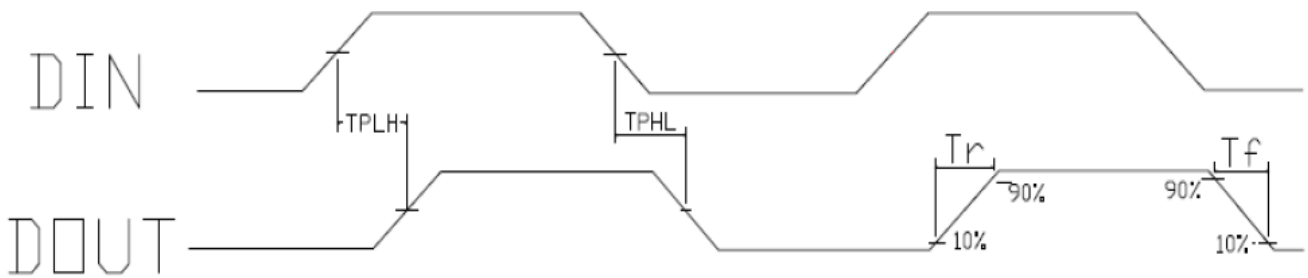

Timing Waveforms

1. Input Code

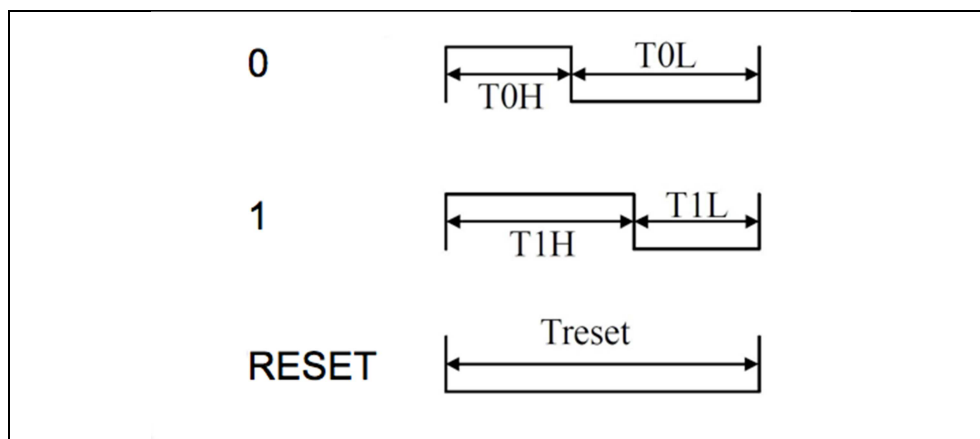

2. The data transmission time ($T_H+T_L=1.25\mu s\pm 600ns$):

Name	Description	Typ. value	error
T0H	0 code, high level time	0.3 μs	$\pm 0.15\mu s$
T0L	0 code, low level time	0.9 μs	$\pm 0.15\mu s$
T1H	1 code, high level time	0.9 μs	$\pm 0.15\mu s$
T1L	1 code, low level time	0.3 μs	$\pm 0.15\mu s$
Trst	Reset code, low level time	80 μs	

3. Connection Scheme

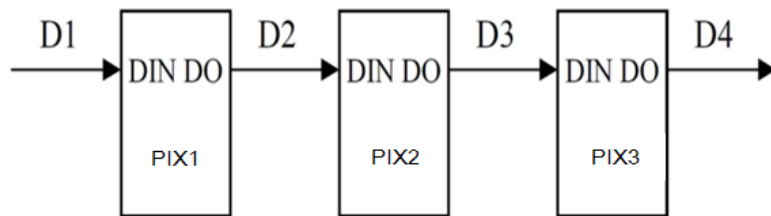

4. Data Transfer Format

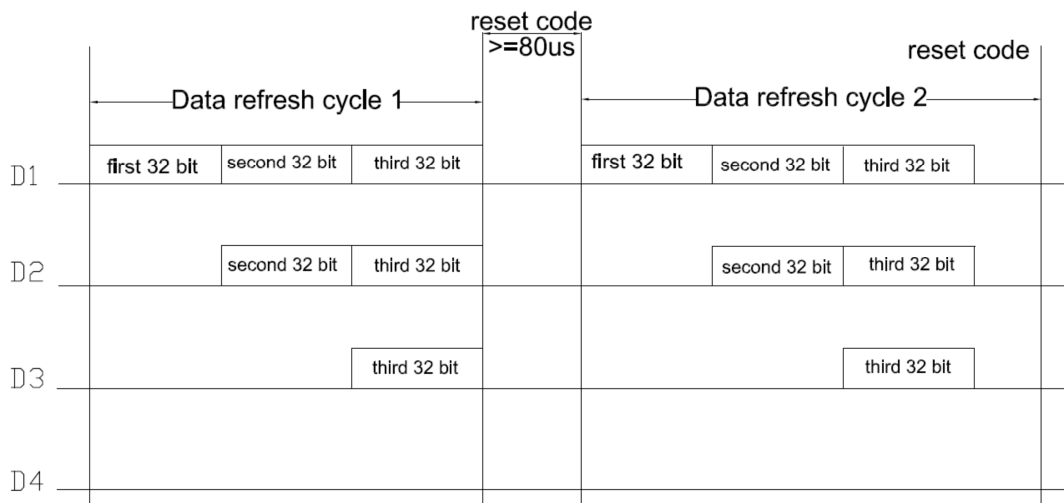

Note: the D1 sends data for MCU, D2, D3, D4 for data forwarding automatic shaping cascade circuit.

5. The data structure of 32bit

G7	G6	G5	G4	G3	G2	G1	G0	R7	R6	R5	R4
R3	R2	R1	R0	B7	B6	B5	B4	B3	B2	B1	B0
W7	W6	W5	W4	W3	W2	W1	W0				

Note: high starting, in order to send data (G7 - G6 - W0)

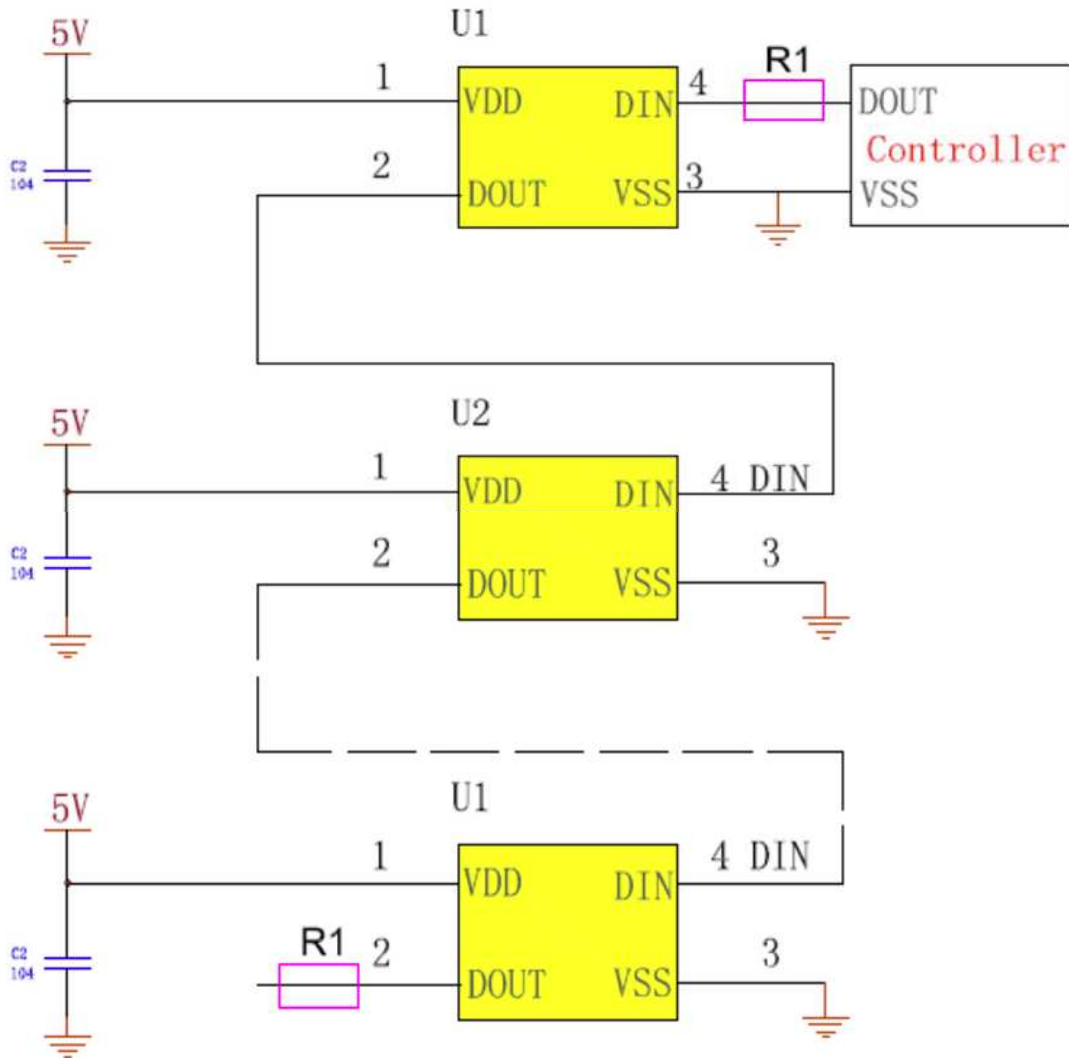
Typical Application Circuit

Product signal input and output must be connected in series with protection resistor R1. R1 depends on the size of the cascade amount, the greater the number of cascade, the smaller R1. The general recommended value is between 200-2K Ω , usually the recommended value is typical 500 Ω .

Color Bin Specification

Name	Code	λ_d MIN (nm)	λ_d MAX (nm)
Red	R1	620	625
	R2	625	630
Blue	B5	460	465
	B6	465	470
Green	G2	515	520
	G3	520	525
	G4	525	530

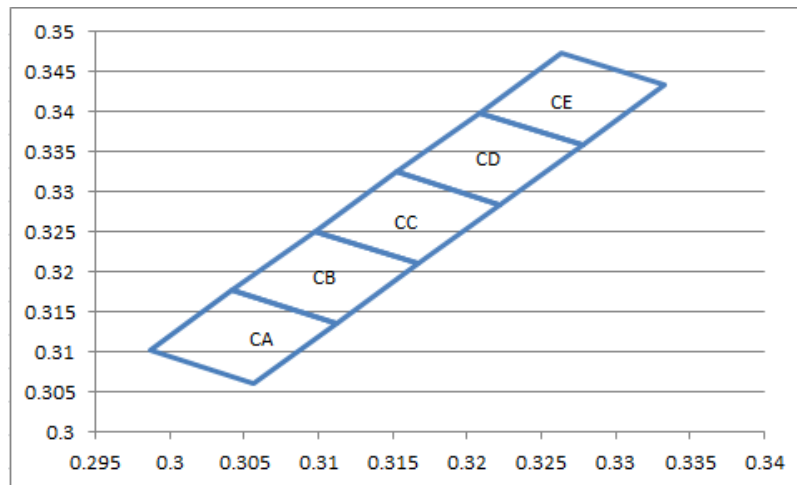
Cool White: 5000K~7500K

CA				
X	0.305649	0.29869	0.30422	0.31118
Y	0.30617	0.31022	0.31765	0.3136

CB				
X	0.311181	0.30422	0.30975	0.31671
Y	0.3136	0.31765	0.32508	0.32103

CC				
X	0.316713	0.30975	0.31529	0.32225
Y	0.32103	0.32508	0.33252	0.32847

CD				
X	0.322245	0.31529	0.32082	0.32778
Y	0.32847	0.33252	0.33995	0.3359

CE				
X	0.327777	0.32082	0.32635	0.33331
Y	0.3359	0.33995	0.34738	0.34333

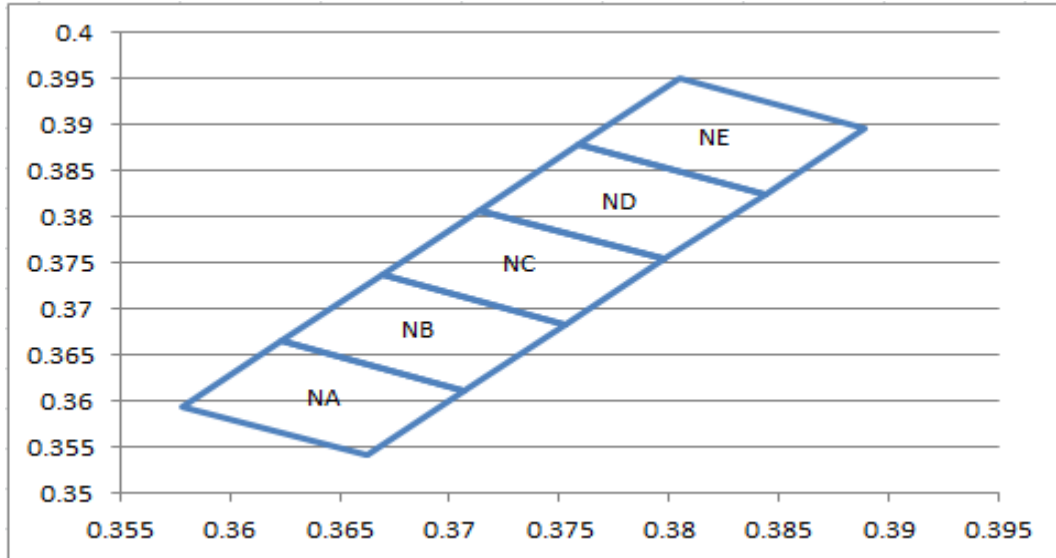
Neutral White: 3500K~5000K

NA				
X	0.3662	0.3578	0.3623	0.3707
Y	0.3541	0.3594	0.3666	0.3612

NB				
X	0.3707	0.3623	0.3669	0.3753
Y	0.3612	0.3666	0.3737	0.3683

NC				
X	0.3753	0.3669	0.3714	0.3798
Y	0.3683	0.3737	0.3808	0.3754

ND				
X	0.3798	0.3714	0.3759	0.3844
Y	0.3754	0.3808	0.3879	0.3825

NE				
X	0.3844	0.3759	0.3805	0.3889
Y	0.3825	0.3879	0.395	0.3897

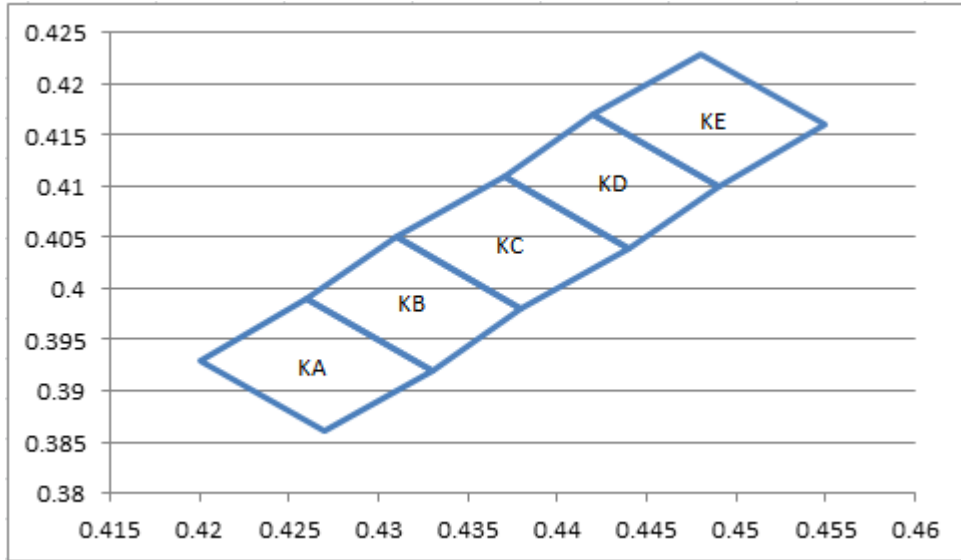
Warm White: 2700K~3500K

KA				
X	0.427	0.42	0.426	0.433
Y	0.386	0.393	0.399	0.392

KB				
X	0.433	0.426	0.431	0.438
Y	0.392	0.399	0.405	0.398

KC				
X	0.438	0.431	0.437	0.444
Y	0.398	0.405	0.411	0.404

KD				
X	0.444	0.437	0.442	0.449
Y	0.404	0.411	0.417	0.41

KE				
X	0.449	0.442	0.448	0.455
Y	0.41	0.417	0.423	0.416

LED Performance Graph

Wavelength Characteristics

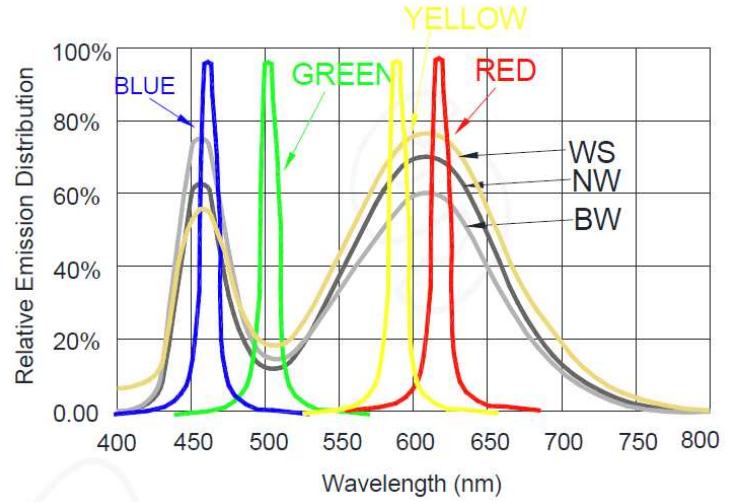
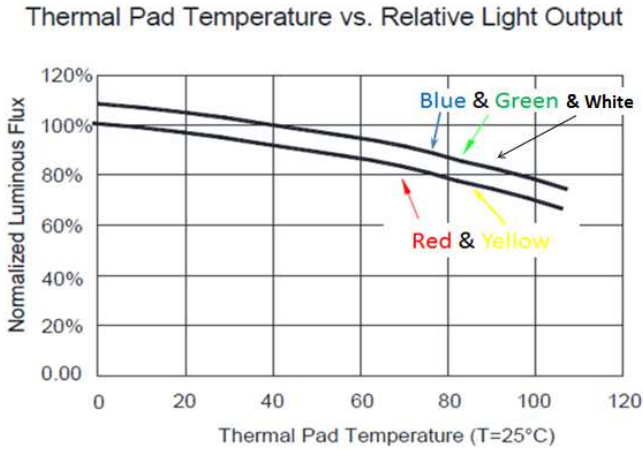

Typical Radiation Pattern 120°

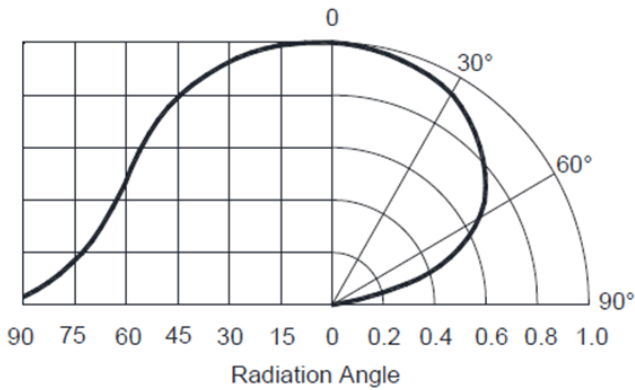

Ordering Information

Product	Emission Color	Iv (mcd) Typ.	Wavelength (Wd) / CCT Typ.	Orderable Part Number
IN-PI55QATPRPGBPBW-60	R	300	625	IN-PI55QATPRPGBPBW-60
	G	850	520	
	B	150	465	
	W	1850	6000k	
IN-PI55QATPRPGBPBW-40	R	300	625	IN-PI55QATPRPGBPBW-40
	G	850	520	
	B	150	465	
	W	1850	4000k	
IN-PI55QATPRPGBPBW-30	R	300	625	IN-PI55QATPRPGBPBW-30
	G	850	520	
	B	150	465	
	W	1850	3000k	

Label Specifications

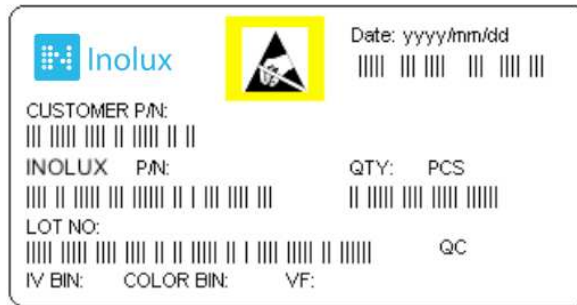

Inolux P/N:

I	N	PI	-	55	Q	A	T	(X)	-	XX	-	X	X	X	X
		Product		Package	Die Qty.	Variation	Orientation	Current		Color		Color Temperature of White		Customized Stamp-off	
Inolux		PI- Single trace IC PC- Clock Function IC		55QA = 5.0 x 5.0 x 1.6 mm			T = Top Mount	P=12mA 5 = 5mA		R = 624nm G = 520nm B = 470nm W = 2700K-7000K		60: Cool White 40: Neutral White 30: Warm White			

Lot No.:

Z	2	0	1	7	01	24	001
Internal Tracker	Year (2017, 2018,)				Month	Date	Serial

Precautions

Please read the following notes before using the product:

1. Storage

- 1.1 Do not open moisture proof bag before the products are ready to use.
- 1.2 Before opening the package, the LEDs should be kept at 30°C or less and 80%RH or less.
- 1.3 The LEDs should be used within a year.
- 1.4 After opening the package, the LEDs should be kept at 30°C or less and 60%RH or less.
- 1.5 The LEDs should be used within 24 hours (1 days) after opening the package.
- 1.6 If the moisture adsorbent material has fabled away or the LEDs have exceeded the storage time, baking treatment should be performed using the following conditions. Baking treatment: 60±5°C for 24 hours.

2. Soldering Condition

Recommended soldering conditions:

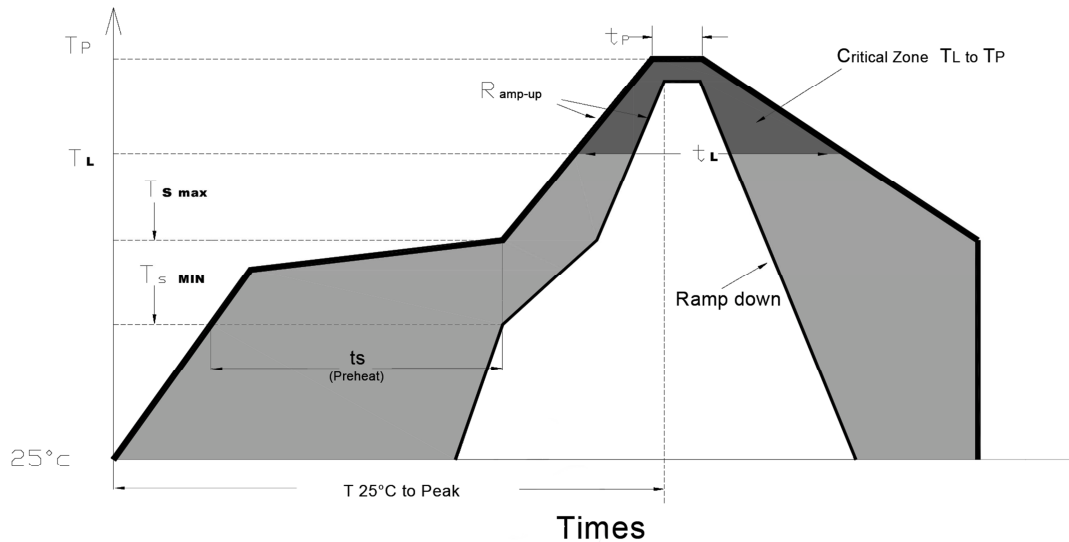

Profile Feature	Lead-Free Solder
Average Ramp-Up Rate (T_s^{max} to T_p)	3°C/second max.
Preheat: Temperature Min (T_s^{min})	150°C
Preheat: Temperature Max (T_s^{max})	200°C
Preheat: Time ($t_{s min}$ to $t_{s max}$)	60-180 seconds
Time Maintained Above: Temperature (T_L)	217 °C
Time Maintained Above: Time (t_L)	60-150 seconds
Peak/Classification Temperature (T_p)	240 °C
Time Within 5°C of Actual Peak Temperature (t_p)	<10 seconds
Ramp-Down Rate	6°C/second max.
Time 25 °C to Peak Temperature	<6 minutes max.

Note: Excessive soldering temperature and / or time might result in deformation of the LED lens or catastrophic failure of the LED.

3. Soldering Iron

Each terminal is to go to the tip of soldering iron temperature less than 260°C for 5 seconds within once in less than the soldering iron capacity 25W. Leave two seconds and more intervals, and do soldering of each terminal. Be careful because the damage of the product is often started at the time of the hand solder.

4. Repairing

Repair should not be done after the LEDs have been soldered. When repairing is unavoidable, a double-head soldering iron should be used (as below figure). It should be confirmed beforehand whether the characteristics of the LEDs will or will not be damaged by repairing.

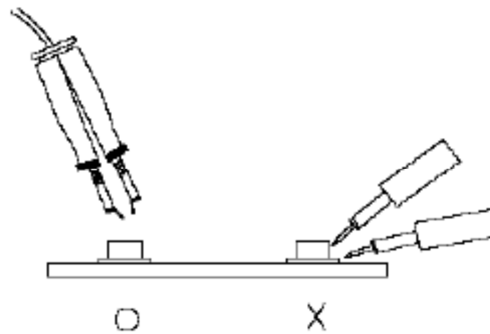

5. Caution in ESD

Static Electricity and surge damages the LED. It is recommended to use a wristband or anti-electrostatic glove when handling the LED. All devices, equipment and machinery must be properly grounded.

Revision History

Changes since last revision	Page	Version No.	Revision Date
Initial Release		1.0	05-31-2018
Format adjustment		1.1	07-01-2018
Format adjustment		1.2	08-06-2018

DISCLAIMER

INOLUX reserves the right to make changes without further notice to any products herein to improve reliability, function or design. INOLUX does not assume any liability arising out of the application or use of any product or circuit described herein; neither does it convey any license under its patent rights, nor the rights of others.

LIFE SUPPORT POLICY

INOLUX's products are not authorized for use as critical components in life support devices or systems without the express written approval of the President of INOLUX or INOLUX CORPORATION. As used herein:

1. Life support devices or systems are devices or systems which, (a) are intended for surgical implant into the body, or (b) support or sustain life, and (c) whose failure to perform when properly used in accordance with instructions for use provided in the labeling, can be reasonably expected to result in a significant injury of the user.
2. A critical component in any component of a life support device or system whose failure to perform can be reasonably expected to cause the failure of the life support device or system, or to affect its safety or effectiveness.