

THIS DRAWING IS UNPUBLISHED.

RELEASED FOR PUBLICATION

© COPYRIGHT BY TYCO ELECTRONICS CORPORATION. ALL RIGHTS RESERVED.

ALL RIGHTS RESERVED.

LOC DIST

REVISIONS

P	LTR	DESCRIPTION	DATE	DWN	APVD
	B	REVISED PER ECO-07-029482	2/19/08	SS	MW

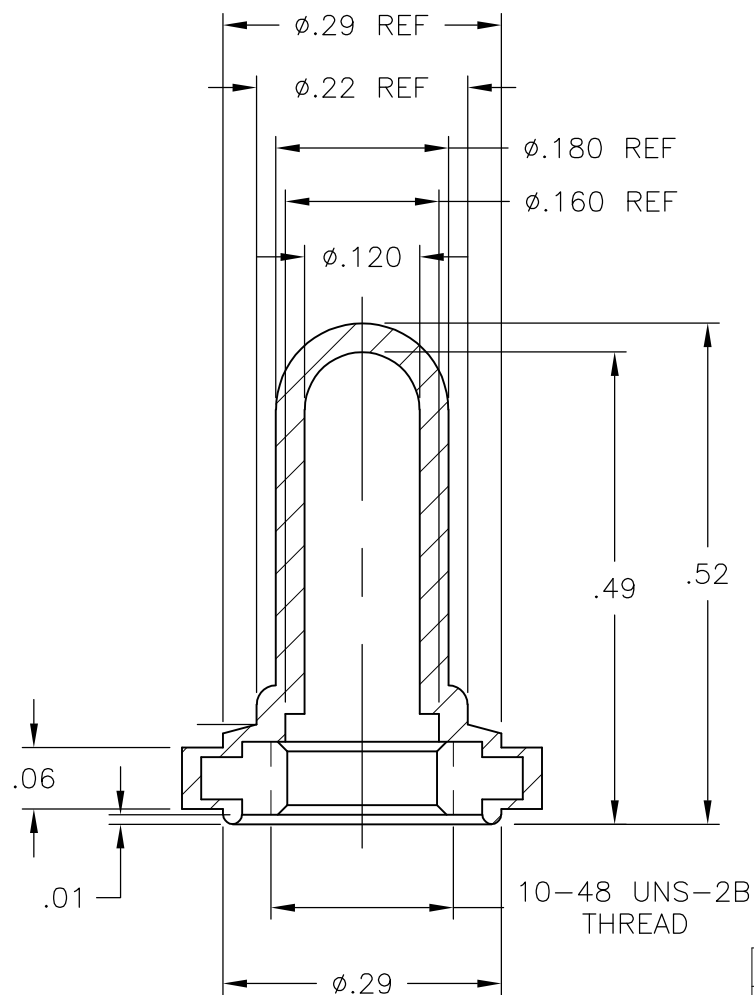
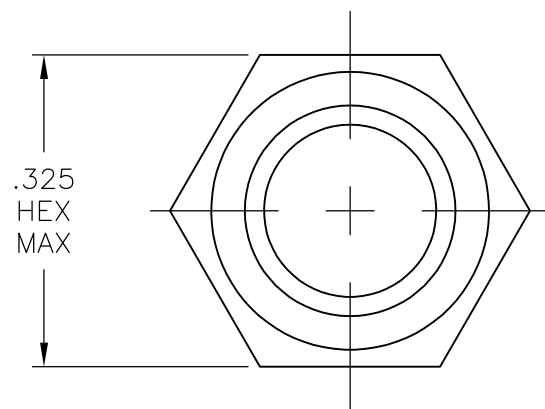

1. SOME DIMENSIONS MAY VARY DUE TO DIFFERENT COMPOUND SHRINKAGE FACTOR.
2. MINOR FLASH ACCEPTABLE ON INSERT THREAD.
3. BLACK FINISH/NICKEL PLATING INSIDE THREADS REMOVED DUE TO MOLDING PROCESS PERMITTED.
4. RUBBER TO METAL BOND MUST MEET OR EXCEED THE TEAR STRENGTH OF RUBBER.
5. COMPONENTS MUST COMPLY WITH THE EUROPEAN DIRECTIVE 2002/95/EC ON RESTRICTION OF THE USE OF CERTAIN HAZARDOUS SUBSTANCES IN ELECTRICAL AND ELECTRONIC EQUIPMENT (ROHS DIRECTIVE).

B1048804	BRASS, NICKEL PLATE PER QQ-N-290	SILICONE, COLOR GRAY	1825609-3
B1048204	BRASS, NICKEL PLATE PER QQ-N-290	SILICONE, COLOR RED	1825609-2
B1048004	BRASS, BLACK OXIDE PER MIL-F-495	SILICONE, COLOR BLACK	1825609-1
ALCO NUMBER	HEX NUT MATERIAL	RUBBER BOOT MATERIAL	PART NUMBER

THIS DRAWING IS A CONTROLLED DOCUMENT.		DWN S SCHLEGEL 19FEB2008	Tyco Electronics Corporation Harrisburg, PA 17105-3608	
DIMENSIONS: INCHES		CHK M WILBOURN 2/19/08	NAME 10-48 TOGGLE SWITCH BOOT SEAL	
TOLERANCES UNLESS OTHERWISE SPECIFIED:		APVD M WILBOURN 2/19/08	PRODUCT SPEC -	
0 PLC ± -		APPLICATION SPEC -		
1 PLC ± -		SIZE A3		
2 PLC ± .01		CAGE CODE 00779		
3 PLC ± .005		DRAWING NO G-1825609		
4 PLC ± -		RESTRICTED TO -		
ANGLES ± 5°		SCALE 5:1		
MATERIAL -		SHEET 1 OF 1		
FINISH -		REV B		
		CUSTOMER DRAWING		