

DESIGNED & DIMENSIONED
IN MILLIMETERS [INCHES]

MEC5-XXX-XX-X-RA-XX-TR

DO NOT
SCALE FROM
THIS PRINT

No OF POSITIONS (PER ROW)

-030, -040, -050,
-060, -070, -080

TAPE & REEL

OPTION
(REQUIRED)

-W1: WELD TAB THROUGH HOLE
(SEE FIG 2, SHT 3)
-W2: WELD TAB SURFACE MOUNT
(SEE FIG 1)

CARD THICKNESS

-01: FOR .062" THICK BOARD

PLATING SPECIFICATION

-L: 10µ" GOLD IN CONTACT AREA,
MATTE TIN TAIL
-S: 30µ" GOLD IN CONTACT AREA,
MATTE TIN TAIL

ROW SPECIFICATION

-RA: RIGHT ANGLE

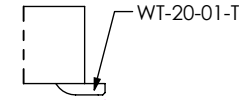
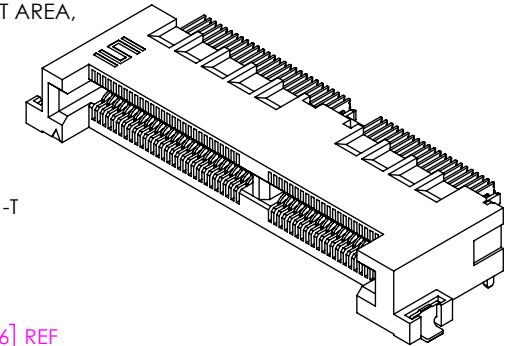
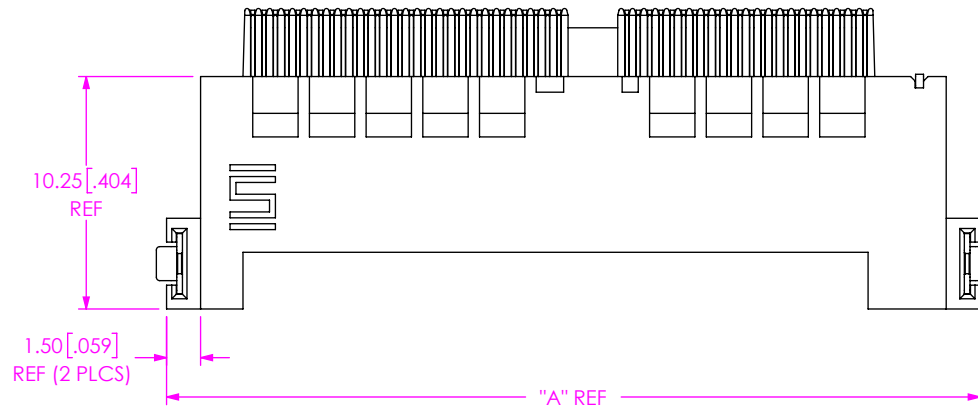

DETAIL 'A'
SCALE 6:1

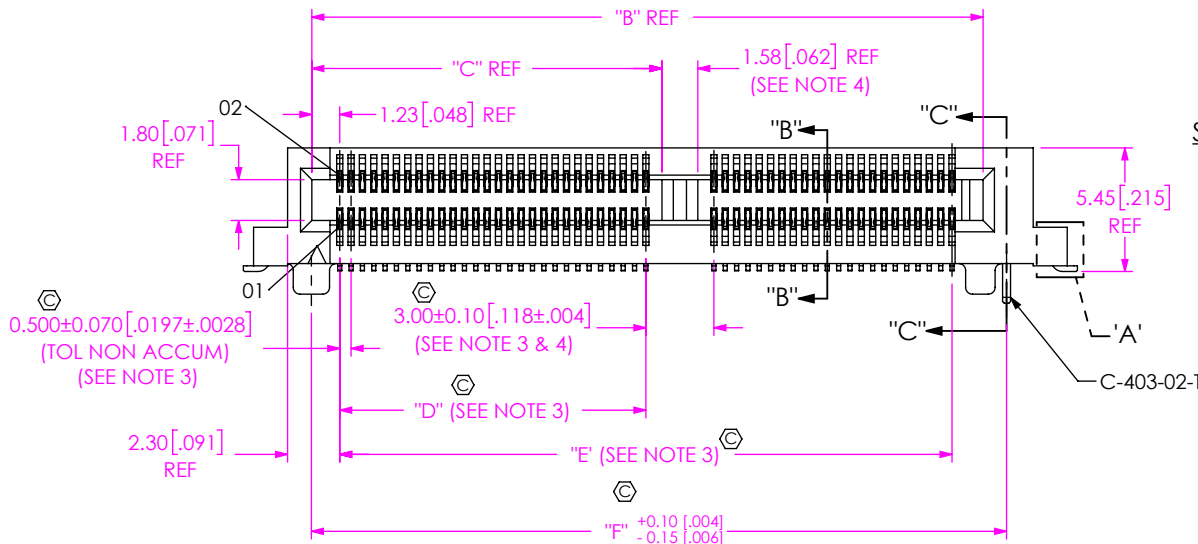

TABLE 1

NO OF POS	"A"	"B"	"C"
-030	23.38 [0.920]	17.10 [0.673]	N/A
-040	28.38 [1.117]	22.10 [0.870]	N/A
-050	35.88 [1.413]	29.60 [1.165]	15.44 [0.608]
-060	40.88 [1.609]	34.60 [1.362]	17.94 [0.706]
-070	45.88 [1.806]	39.60 [1.559]	20.44 [0.805]
-080	50.88 [2.003]	44.60 [1.756]	22.94 [0.903]

NO OF POS	"D"	"E"	"F"
-030	N/A	14.50 [0.571]	18.16 [0.715]
-040	N/A	19.50 [0.768]	23.16 [0.912]
-050	13.50 [0.531]	27.00 [1.063]	30.66 [1.207]
-060	16.00 [0.630]	32.00 [1.260]	35.66 [1.404]
-070	18.50 [0.728]	37.00 [1.457]	40.66 [1.601]
-080	21.00 [0.827]	42.00 [1.654]	45.66 [1.798]

FIG 1
MEC5-050-01-X-D-RA-W2-TR SHOWN

NOTES:

- ⊗ REPRESENTS A CRITICAL DIMENSION.
- MINIMUM PUSHOUT FORCE: 0.5 LBS FOR C-401, WT-20, WT-51; 1.0 LBS FOR C-403.
- MEASURE BOTH TOP AND BOTTOM ROWS.
- POLARIZATION RIB IS NOT PRESENT ON -030 & -040 POSITIONS.
- FOR QUANTITIES UP TO 49 PCS., NO LEADER, TRAILER OR REEL WILL BE SUPPLIED.
FOR QUANTITIES OF 50-124 PCS., NO LEADER OR TRAILER WILL BE SUPPLIED,
SPLICES MAY BE PRESENT.

UNLESS OTHERWISE SPECIFIED,
DIMENSIONS ARE IN MILLIMETERS.
TOLERANCES ARE:
DECIMALS ANGLES
X.X: ±0.3 [.01] 2°
X.XX: ±0.10 [.004]
X.XXX: ±0.051 [.0020]

PROPRIETARY NOTE
THIS DOCUMENT CONTAINS CONFIDENTIAL AND PROPRIETARY INFORMATION AND ALL DESIGN, MANUFACTURING, REPRODUCTION, USE, PATENT RIGHTS AND SALES RIGHTS ARE EXPRESSLY RESERVED BY SAMTEC, INC. THIS DOCUMENT SHALL NOT BE DISCLOSED, IN WHOLE OR PART, TO ANY UNAUTHORIZED PERSON OR ENTITY NOR REPRODUCED, TRANSFERRED OR INCORPORATED IN ANY OTHER PROJECT IN ANY MANNER WITHOUT THE EXPRESS WRITTEN CONSENT OF SAMTEC, INC.

MATERIAL: DO NOT SCALE DRAWING SHEET SCALE: 3:1
INSULATOR: LCP, UL 94 V0, COLOR: BLACK
CONTACT: Cu ALLOY
WELD TAB: BRASS ALLOY



520 PARK EAST BLVD, NEW ALBANY, IN 47150
PHONE: 812-944-6733 FAX: 812-948-5047
e-Mail: info@SAMTEC.com code 53322

DESCRIPTION:
0.5mm HIGH SPEED EDGE CARD ASSEMBLY
DWG. NO.
MEC5-XXX-XX-X-RA-XX-TR
BY: JESSIE W 6/3/2015 SHEET 1 OF 4

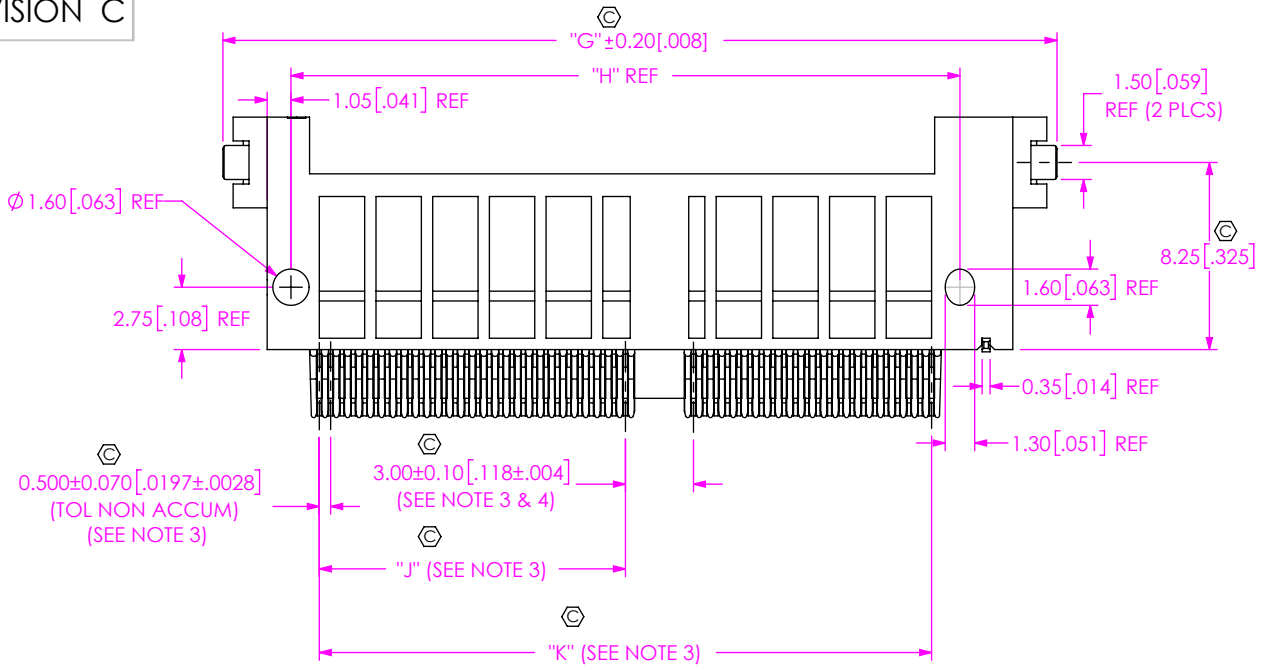

BOTTOM VIEW

TABLE 2		
NO OF POS	"G"	"H"
-030	24.28 [0.956]	17.00 [0.669]
-040	29.28 [1.153]	22.00 [0.866]
-050	36.78 [1.448]	29.50 [1.161]
-060	41.78 [1.645]	34.50 [1.358]
-070	46.78 [1.842]	39.50 [1.555]
-080	51.78 [2.039]	44.50 [1.752]

NO OF POS	"J"	"K"
-030	N/A	14.50 [0.571]
-040	N/A	19.50 [0.768]
-050	13.50 [0.531]	27.00 [1.063]
-060	16.00 [0.630]	32.00 [1.260]
-070	18.50 [0.728]	37.00 [1.457]
-080	21.00 [0.827]	42.00 [1.654]

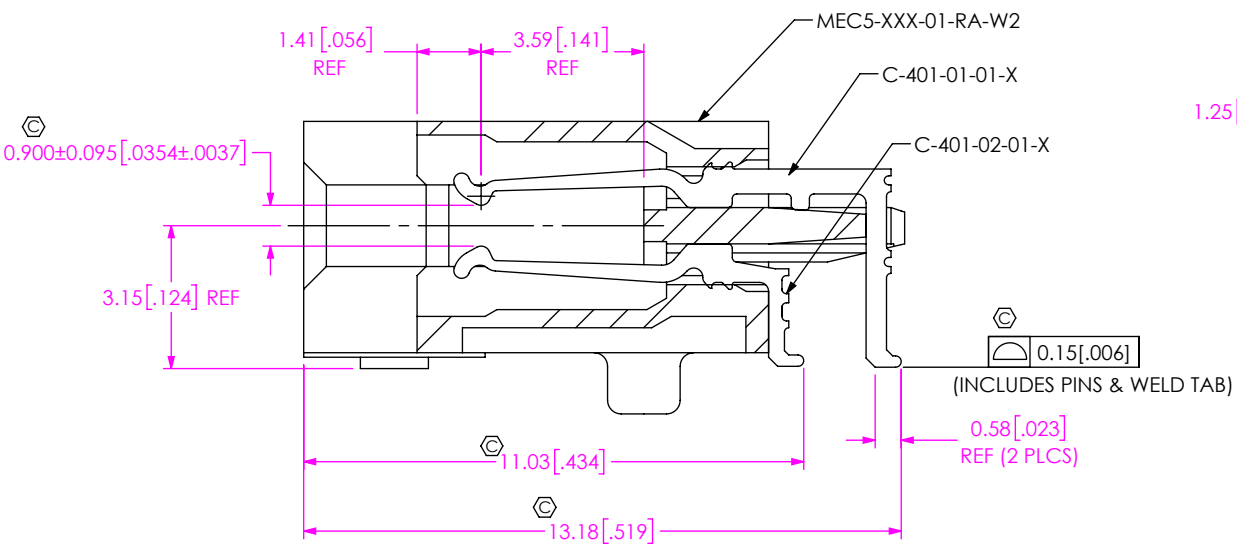

SECTION "B"- "B"
SCALE 6 : 1

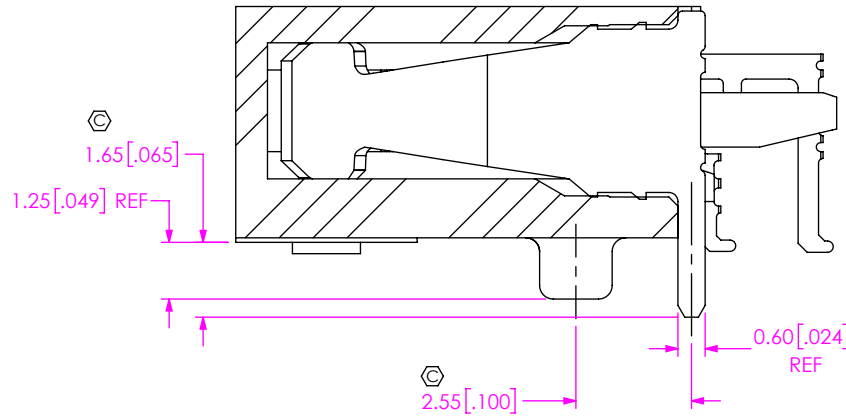

SECTION "C"- "C"
SCALE 6 : 1

PROPRIETARY NOTE
 THIS DOCUMENT CONTAINS CONFIDENTIAL AND PROPRIETARY INFORMATION AND ALL DESIGN, MANUFACTURING, REPRODUCTION, USE, PATENT RIGHTS AND SALES RIGHTS ARE EXPRESSLY RESERVED BY SAMTEC, INC. THIS DOCUMENT SHALL NOT BE DISCLOSED, IN WHOLE OR PART, TO ANY UNAUTHORIZED PERSON OR ENTITY NOR REPRODUCED, TRANSFERRED OR INCORPORATED IN ANY OTHER PROJECT IN ANY MANNER WITHOUT THE EXPRESS WRITTEN CONSENT OF SAMTEC, INC.

DO NOT SCALE DRAWING

SHEET SCALE: 3:1



520 PARK EAST BLVD, NEW ALBANY, IN 47150
 PHONE: 812-944-6733 FAX: 812-948-5047
 e-Mail info@SAMTEC.com code 55322

DESCRIPTION:
 0.5mm HIGH SPEED EDGE CARD ASSEMBLY

DWG. NO.
 MEC5-XXX-XX-X-RA-XX-TR

BY: JESSIE W 6/3/2015 SHEET 2 OF 4

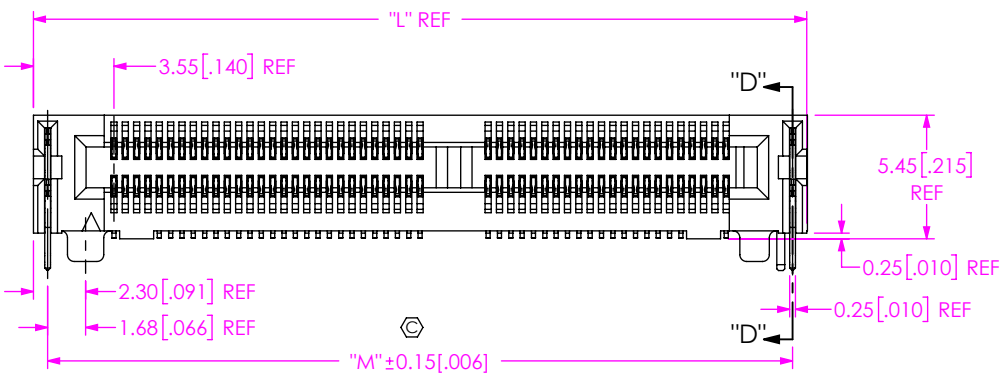
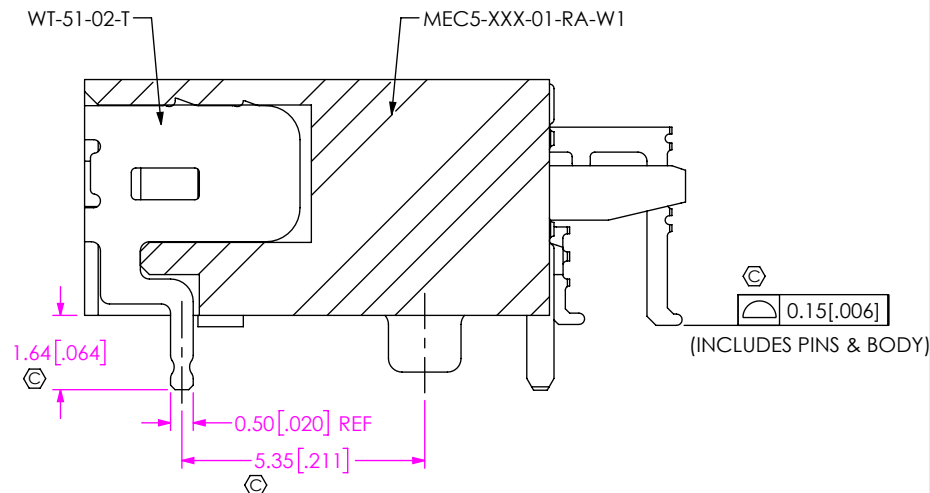
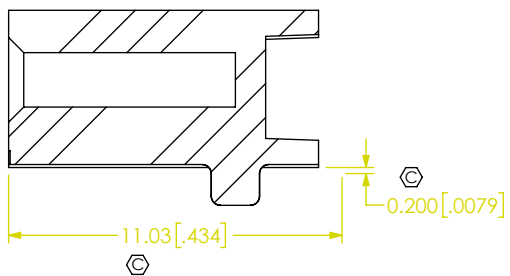

FIG 2
MEC5-050-01-X-D-RA-W1-TR SHOWN
(DIFFERENT AS SHOWN, OTHERWISE SAME AS FIG 1)



SECTION "D"-"D"
SCALE 6:1



IN-PROCESS 1 FOR W1
FILL C-401-02-01-X

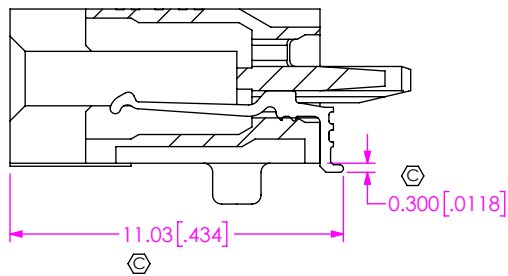

IN-PROCESS 1 FOR W2
FILL C-401-02-01-X

TABLE 3

NO OF POS	"L"	"M"
-030	22.88 [0.901]	21.63 [0.852]
-040	27.88 [1.098]	26.63 [1.048]
-050	35.38 [1.393]	34.13 [1.344]
-060	40.38 [1.590]	39.13 [1.541]
-070	45.38 [1.787]	44.13 [1.737]
-080	50.38 [1.983]	49.13 [1.934]

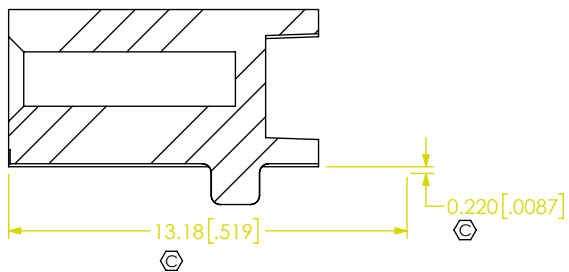

IN-PROCESS 2 FOR W1
FILL C-401-01-01-X

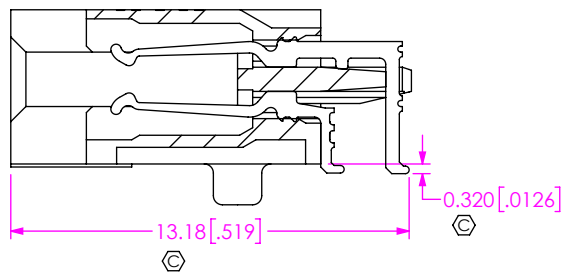

IN-PROCESS 2 FOR W2
FILL C-401-01-01-X

PROPRIETARY NOTE
THIS DOCUMENT CONTAINS CONFIDENTIAL AND PROPRIETARY INFORMATION AND ALL DESIGN, MANUFACTURING, REPRODUCTION, USE, PATENT RIGHTS AND SALES RIGHTS ARE EXPRESSLY RESERVED BY SAMTEC, INC. THIS DOCUMENT SHALL NOT BE DISCLOSED, IN WHOLE OR PART, TO ANY UNAUTHORIZED PERSON OR ENTITY NOR REPRODUCED, TRANSFERRED OR INCORPORATED IN ANY OTHER PROJECT IN ANY MANNER WITHOUT THE EXPRESS WRITTEN CONSENT OF SAMTEC, INC.

DO NOT SCALE DRAWING

SHEET SCALE: 3:1



520 PARK EAST BLVD, NEW ALBANY, IN 47150
PHONE: 812-944-6733 FAX: 812-948-5047
e-Mail info@SAMTEC.com code 55322

DESCRIPTION:
0.5mm HIGH SPEED EDGE CARD ASSEMBLY

DWG. NO.
MEC5-XXX-XX-X-RA-XX-TR

BY: JESSIE W 6/3/2015 SHEET 3 OF 4

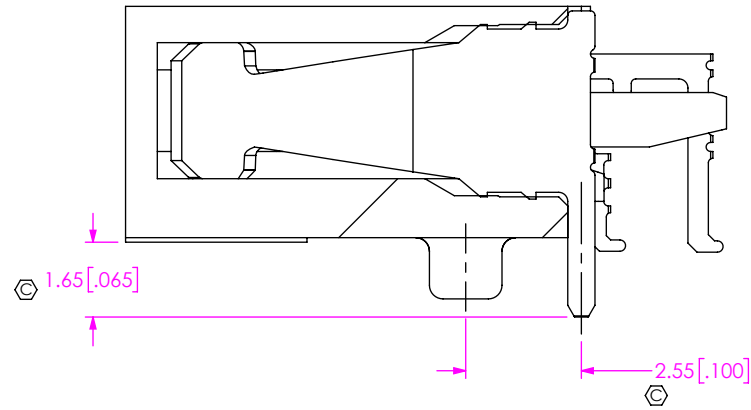

IN-PROCESS 3
FILL C-403-02-T

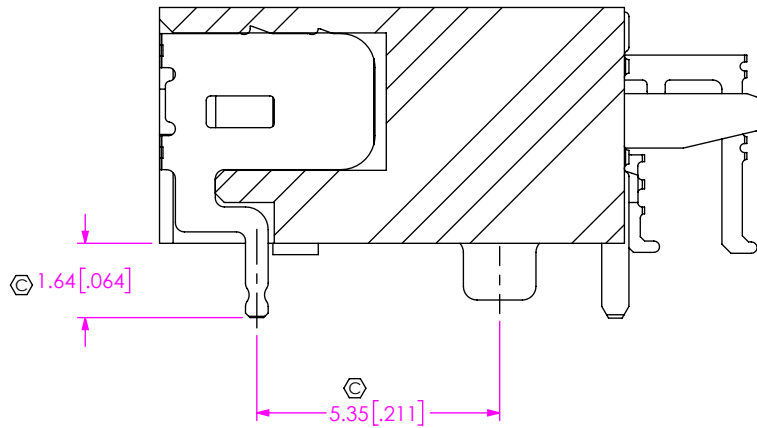

IN-PROCESS 4 FOR W1
FILL WT-51-02-T

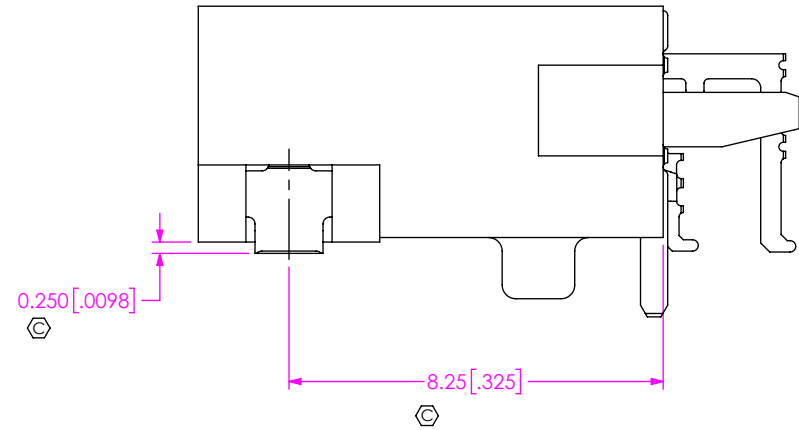

IN-PROCESS 4 FOR W2
FILL WT-20-01-T

<p>PROPRIETARY NOTE</p> <p>THIS DOCUMENT CONTAINS CONFIDENTIAL AND PROPRIETARY INFORMATION AND ALL DESIGN, MANUFACTURING, REPRODUCTION, USE, PATENT RIGHTS AND SALES RIGHTS ARE EXPRESSLY RESERVED BY SAMTEC, INC. THIS DOCUMENT SHALL NOT BE DISCLOSED, IN WHOLE OR PART, TO ANY UNAUTHORIZED PERSON OR ENTITY NOR REPRODUCED, TRANSFERRED OR INCORPORATED IN ANY OTHER PROJECT IN ANY MANNER WITHOUT THE EXPRESS WRITTEN CONSENT OF SAMTEC, INC.</p>	<p>samtec</p> <p>520 PARK EAST BLVD, NEW ALBANY, IN 47150 PHONE: 812-944-6733 FAX: 812-948-5047 e-Mail info@SAMTEC.com code 55322</p>
<p>SHEET SCALE: 3:1</p>	<p>DESCRIPTION: 0.5mm HIGH SPEED EDGE CARD ASSEMBLY</p>
	<p>DWG. NO. MEC5-XXX-XX-X-RA-XX-TR</p> <p>BY: JESSIE W 6/3/2015 SHEET 4 OF 4</p>