

LC SIMPLEX PC SINGLEMODE OPTICAL PLUG WITH EXTENDED REAR BODY FOR Ø900 µM CABLE

 Packaging
100

 Series
LC

 Issue
30 JAN 06

 Page
1 / 2

Outer plug body : color BEIGE

Monobloc

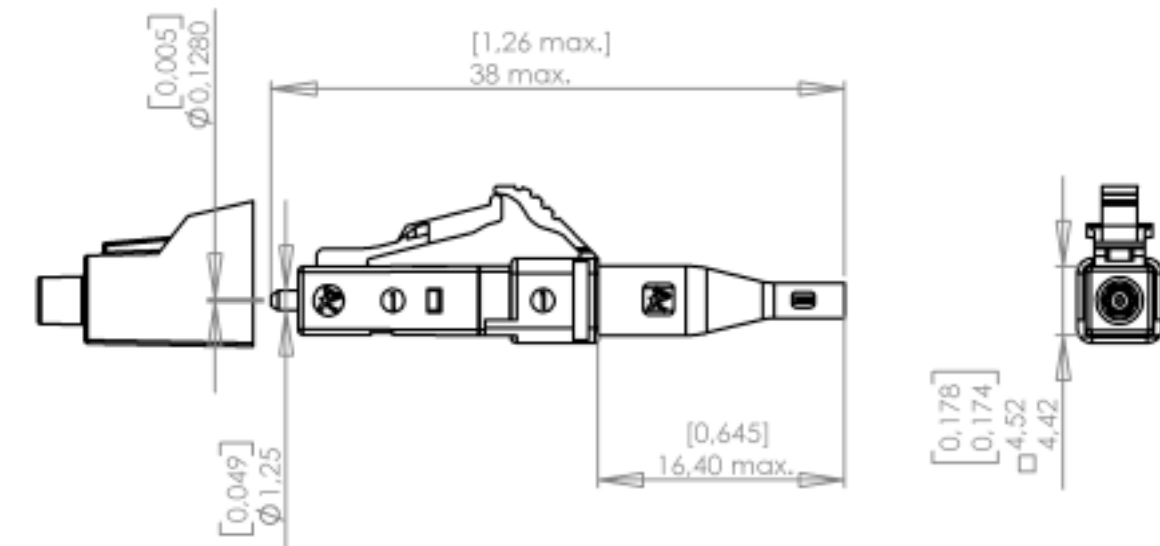

Scale : 1/1

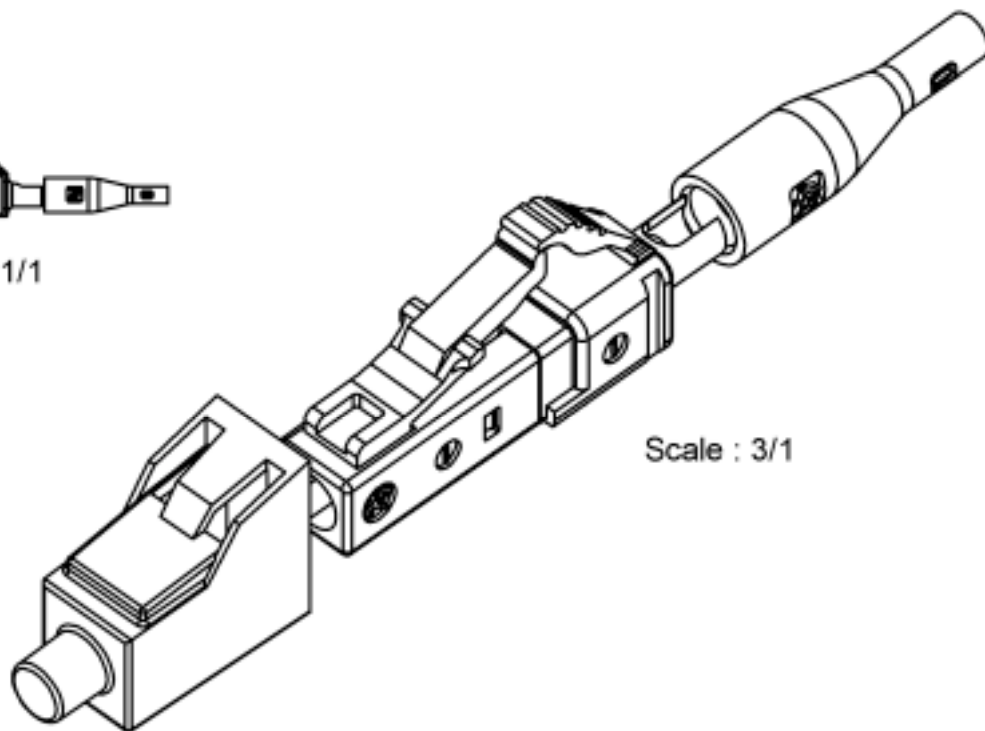

Scale : 3/1

Original dimensions in mm [inch]

LC SIMPLEX PC SINGLEMODE OPTICAL PLUG WITH EXTENDED REAR BODY FOR Ø900 µM CABLE

Packaging
100

Series
LC

Issue
30 JAN 06

Page
2 / 2

Outer plug body : color BEIGE

Monobloc

GENERAL

- ❑ **TYPE** IEC 61754-20 (LC)
Multimode Zirconia Ø1,25 ferrule
RJ -45 latching connector system
- ❑ **FERRULE SIZE** 128 µm
- ❑ **FIBER SIZE** 62,5/125µm multimode
- ❑ **CABLE SIZE & TYPE** Ø0,9 mm Simplex
- ❑ **CABLING PROCEDURE** Refer to 503.08.500 assembly instruction manual

Can be converted into duplex version using dismountable clip F718 178 006 to be ordered separately.

CHARACTERISTICS (Depending on fibre or cable construction)

- ❑ **OPTICAL** Attenuation at 850 nm and 1300 nm
Attenuation plug mated with reference plug : IEC 61300-3-4 Method B

| PARAMETER | STD |
|--------------------|----------|
| Mean | ≤0.10 dB |
| Standard deviation | ≤0.05 dB |

Attenuation of random mated connectors : IEC 61300-3-34

| PARAMETER | STD |
|--------------------|-----------|
| Mean | ≤0.10 dB |
| Standard deviation | ≤ 0.07 dB |

Return-Loss Maximum loss variation : IEC61300-3-6

| RL | |
|----|--------|
| PC | > 20dB |

- ❑ **MECHANICAL**
 - Vibration test 10 to 55 Hz , 1,5 mm (peak to peak) , 2 Hr/axis
 - Impact test 1,5 m drop , 8 cycles
 - Mechanical Endurance 200 matings
 - Cable retention 7 N
- ❑ **ENVIRONMENTAL**
 - Storage temperature range -40 °C to +85 °C
 - Operating temperature range -40 °C to +70 °C
 - Thermal cycle test -40°C to +75°C , 21 Cycles , 168
 - Humidity/Condensation cycling test 95%RH, -10°C to +65°C, 14 cycles, 168Hr

(Performance and specification : see document GEN – F727 001)