

Waterproof optical connectors with built-in SC/LC-Duplex

SW20 Series

Waterproof

1 or 2 pos.

Bayonet lock

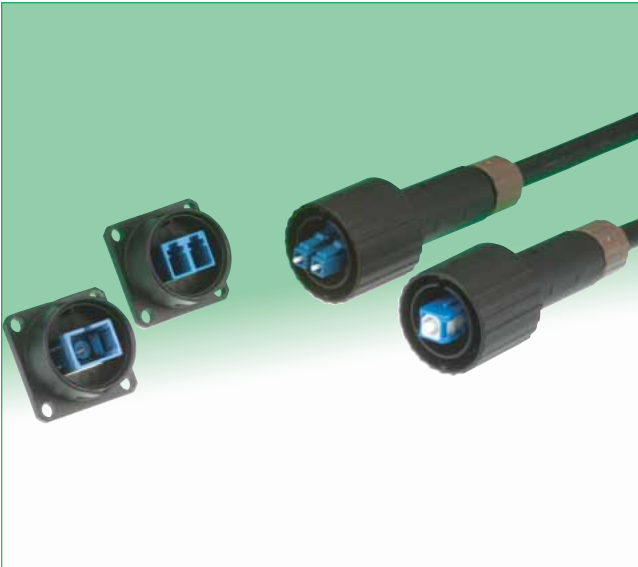

One action lock/unlock mechanism (Patented)

The schematic illustration of internal mechanism. (in case of LC type)

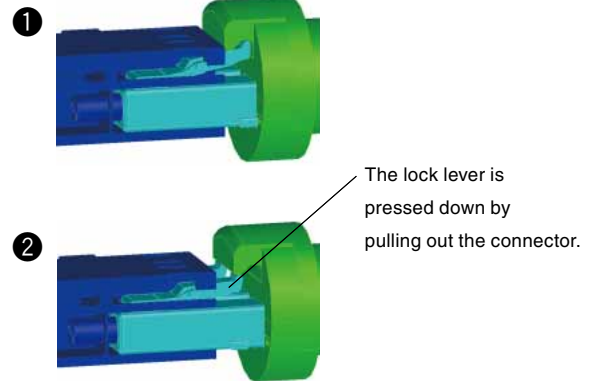

Fig.1

Features

1. Waterproof bayonet lock + standard SC/LC connector

This connector combines a standard optical connector (SC/LC) and optical adaptor (SC/LC), and is covered with a waterproof shell. The bayonet locking mechanism provides a single-action mating/unmating between the receptacle mounted on the chassis and the plug.

2. Designed for harsh outdoor environments

Connector has passed a 1,000 hour salt spray test as well as the IP67 waterproof test when mated or with protective caps in place.

3. Common housing for SW20-SC and SW20-LC

The waterproof outer shell can be used for both the SW20-SC and SW20-LC. This feature simplifies procedures for mounting, mating and unmating.

4. Standard SC/LC connectors for testing

Any cord with a standard optical connector can be used for operation tests during assembly or installation, when water resistance is unnecessary. No special cord is needed.

5. Easy on-site maintenance

In the event of damage, the end face can be repaired by replacing the internal standard patch cord. This eliminates the need for replacement of the entire receptacle. (Fig.2)

During maintenance and repair

Only the harness parts are replaced.

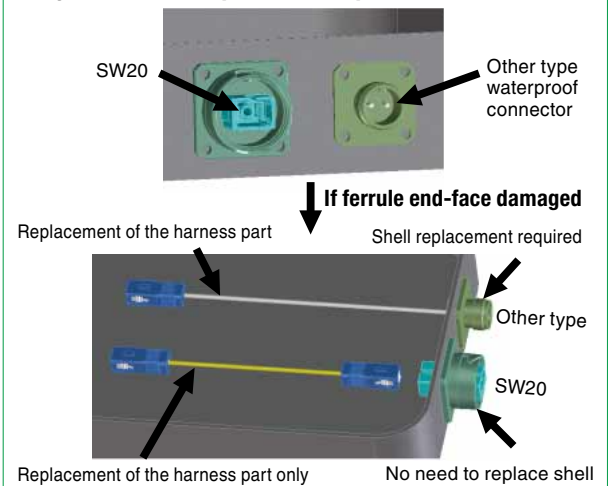

Fig.2

Product Specifications

Ratings	Operating temperature range	-40°C to +85°C	Storage temperature range	-25°C to +70°C (AT PACKING)
	Item	Test method	Requirements	
Optical characteristics	Insertion loss	Wavelength 1310nm (LD) Wavelength 1550nm (LD)	1310nm : 0.4dB max., 1550nm : 0.5dB max.	
	Return loss	Wavelength 1310nm (LD)	40dB min. (SM), 22dB min. (GI)	
Mechanical characteristics	Tensile strength(axial)	A tensile force to cable axially for 1 minutes at 200N.	Insertion loss range : ≤ 0.3dB No Looseness, breakage, cracks	
	Durability (mating/un-mating)	200 times	1) Insertion loss fluctuation after test : 0.3dB max. 2) No visible damage or components dislocation.	
	Vibration	Frequency : 10 to 55Hz, single amplitude of 0.75mm, acceleration of 98.1m/s ² , 2 hours in each of the 3 axis.		
	Shock	Acceleration of 981m/s ² , 6ms duration, half sine shock pulse, 10 cycles in each of the 3 axis.		
Environmental characteristics	Humidity (Temperature/humidity-cycles)	-10°C to +65°C, humidity : 90% to 100% 168 hours. (12H/cycle×14cycle) (Telcordia GR3120-CORE)	1) Insertion loss fluctuation after test : 0.3dB max. 2) No visible damage or components dislocation.	
	Temperature cycle	-40°C to +75°C, 42 cycles, 168hours. (8H/cycle×42cycle) (Telcordia GR326-CORE)		
	Dry heat	240 hours at +85°C		
	Cold	240 hours at -40°C		
	Salt mist	Salt mist : 5% and temperature 35°C or 1000 hours.	No heavy corrosion ruin the function.	
	Water resistance (mating)	Put the product under water for 1min, with air pressure 4.9kPa.	No air leakage.	

Materials / Finish

Part	Plug		Receptacle	
	Material	Finish/Remarks	Material	Finish/Remarks
Housing	Zinc alloy die casting	Chrome plated	Zinc alloy	Chrome plated
	Synthetic resin	UL94V-0		
Oring/gasket	Synthetic rubber	—	Synthetic rubber	—
SC/LC	Depend on each connector. (Synthetic resin, Zirconia, spring)	—	Depend on each adapter. (Synthetic resin, Zirconia)	—
Spring	Steel wire	—	—	—
Others (Internal part)	Phosphor bronze	Nickel plated	—	—
	Zinc alloy	Nickel plated	—	—
	Stainless steel	—	—	—

Product Number Structure

Refer to the chart below when determining the product specifications from the product number.
Please select from the product numbers listed in this catalog when placing orders.

(1) Plug housing

SW20 - **SC** **P** **T75** - **1**

① ② ③ ④ ⑤

① Series name : SW20	③ Plug housing : P
② Connector type : SC...SW20-SC plug LC...SW20-LC plug	④ Cable type T75 : φ7 round cable. ⑤ Suffix

Please contact us in case you need Plug kit only.

(2) Receptacle

SW20 - **SC** **R** - **1**

① ② ③ ④

① Series name : SW20	③ Receptacle R : Receptacle
② Connector type : SC...SW20-SC receptacle LC...SW20-LC recetacle	④ Suffix

(3) Receptacle cap

SW20 - **RC** **1**

① ② ③

① Series name : SW20	③ Suffix 1 : Waterproof cap 3 : Dustproof cap(Not waterproof)
② Receptacle cap RC : Receptacle cap	

(4) Adaptor

SW20 - **LC** **A** - **1**

① ② ③ ④

① Series name : SW20	③ Adaptor A : Adaptor
② Connector type : LC...SW20-LC adaptor	④ Suffix

Plug housing Please contact us for applicable cables.

● SC type

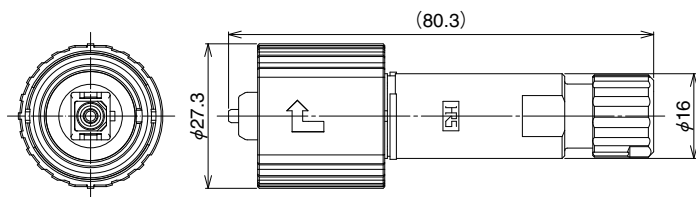

Part No.	HRS No.	SM, GI	Ferulle dimension
SW20-SCPT75-2(22)	717-5019-5 22	SM	φ0.1255
SW20-SCPT75-2(23)	717-5019-5 23	GI	φ0.126

● LC type

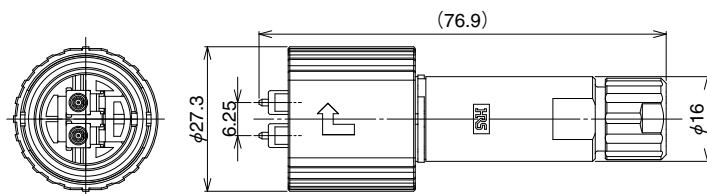

Part No.	HRS No.	SM, GI	Ferulle dimension
SW20-LCPT75-3	717-5508-1 00	SM	φ0.1255
SW20-LCPT75-3(21)	717-5508-1 21	GI	φ0.126

■ Receptacle

● SC type

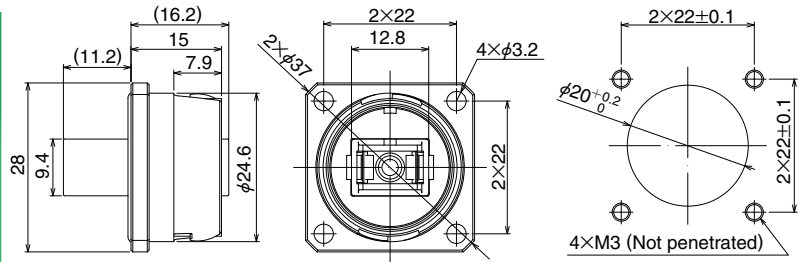

Part No.	HRS No.	Packing style
SW20-SCR-1(01)	717-5002-2 01	1pcs/pack(1 to 9 pcs)
SW20-SCR-1(02)	717-5002-2 02	Tray(10 pcs or more)

Note : LC-type's cutout same as SC-type.

● LC type

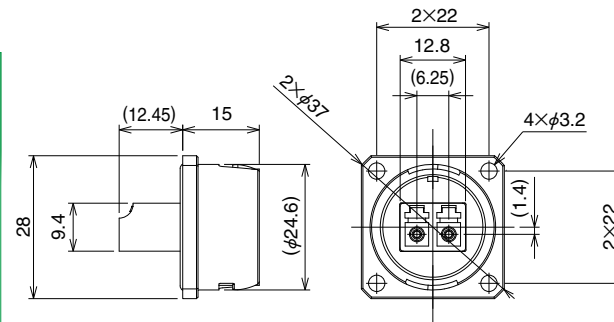
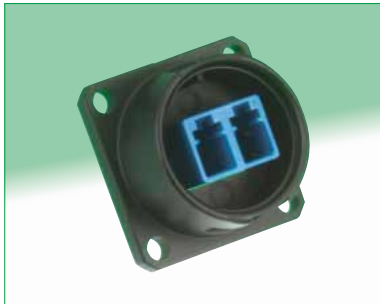

Part No.	HRS No.	Packing style
SW20-LCR-1	717-5004-8 00	1pcs/pack(1 to 9 pcs), Tray(10 pcs or more)

■ Receptacle Cap

● Waterproof type

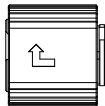

Part No.	HRS No.	Packing style
SW20-RC1(01)	717-5501-2 01	1 pcs/pack

● Dustproof type

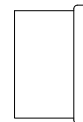

Part No.	HRS No.	Packing style
SW20-RC3	717-5504-0	1 pcs/pack

Note : Without waterproof.

■ Adaptor

● LC type

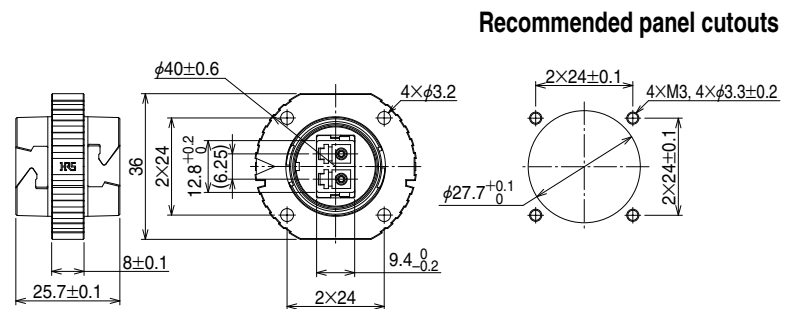

Part No.	HRS No.	Packing style
SW20-LCA-1	717-5028-6 00	1 pcs/pack

◆ Tool

● Hood Insertion Tool (SC, LC)

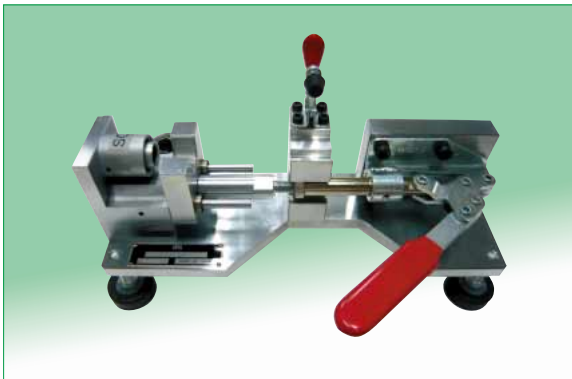

Part No.	HRS No.
SW20-SCLC-T1/CV-MD	902-6065-5 00

Note : When you change SC and LC, please exchange tip attachment before assembling.

● Fastener Insertion Tool (SC, LC)

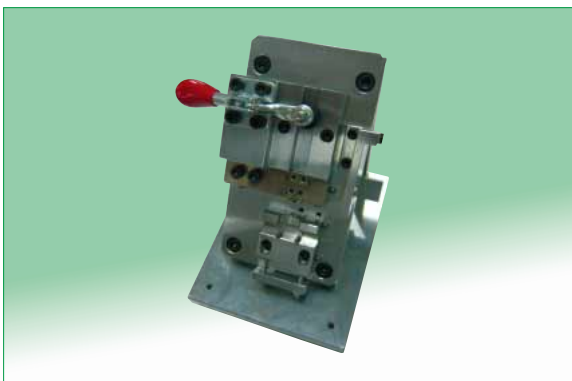

Part No.	HRS No.
SW20-LCPT75-1/CVMD3	902-3227-9 00

Note : When you change SC and LC, please exchange tip attachment before assembling.

● Spring Washer Insertion Tool (SC, LC)

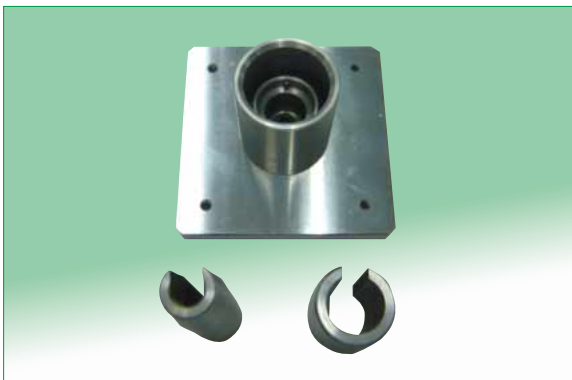

Part No.	HRS No.
SW20-LCPT75-1/CVMD4	902-6074-0 00

● LC Housing A, B, C Insertion Tool (LC)



Part No.	HRS No.
SW20-LCPT75-1/CVMD1	902-3225-3 00

USA:

HIROSE ELECTRIC (U.S.A.), INC. HEADQUARTERS CHICAGO OFFICE
2300 Warrenville Road, Suite 150,
Downers Grove, IL 60515
Phone : +1-630-282-6700
<http://www.hirose.com/us/>

USA:

HIROSE ELECTRIC (U.S.A.), INC. SAN JOSE OFFICE
2841 Junction Ave, Suite 200
San Jose, CA. 95134
Phone : +1-408-253-9640
Fax : +1-408-253-9641
<http://www.hirose.com/us/>

USA:

HIROSE ELECTRIC (U.S.A.), INC. DETROIT OFFICE (AUTOMOTIVE)
17197 N. Laurel Park Drive, Suite 253,
Livonia, MI 48152
Phone : +1-734-542-9963
Fax : +1-734-542-9964
<http://www.hirose.com/us/>

USA:

HIROSE ELECTRIC (U.S.A.), INC. BOSTON OFFICE
300 Brickstone Square Suite 201,
Andover, MA 01810
Phone : +1-978-662-5255

THE NETHERLANDS:

HIROSE ELECTRIC EUROPE B.V.
Hogehillweg #8 1101 CC Amsterdam Z-0
Phone : +31-20-6557460
Fax : +31-20-6557469
<http://www.hirose.com/eu/>

GERMANY:

HIROSE ELECTRIC EUROPE B.V. GERMAN BRANCH
Schoenbergstr. 20, 73760 ostfildern
Phone : +49-711-456002-1
Fax : +49-711-456002-299
<http://www.hirose.com/eu/>

GERMANY:

HIROSE ELECTRIC EUROPE B.V. NUREMBERG OFFICE
Neumeyerstrasse 22-26, 90411 Nurnberg
Phone : +49-911 32 68 89 63
Fax : +49-911 32 68 89 69
<http://www.hirose.com/eu/>

GERMANY:

HIROSE ELECTRIC EUROPE B.V. HANOVER OFFICE
Bayernstr. 3, Haus C 30855 Langenhagen, Germany
Phone : +49-511 97 82 61 30
Fax : +49-511 97 82 61 35
<http://www.hirose.com/eu/>

FRANCE:

HIROSE ELECTRIC EUROPE B.V. PARIS OFFICE
Regus La Garenne Colombes, Place de La Belgique,
71 Boulevard National La Garenne Colombes, 92250, France
Phone : +33 (0) 1 7082 3170
Fax : +33 (1) 7082 3101
<http://www.hirose.com/eu/>

UNITED KINGDOM:

HIROSE ELECTRIC EUROPE BV (UK BRANCH)
4 Newton Court, Kelvin Drive, Knowlhill,
Milton Keynes, MK5 8NH
Phone : +44-1908 202050
Fax : +44-1908 202058
<http://www.hirose.com/eu/>

CHINA:

HIROSE ELECTRIC (SHANGHAI) CO., LTD.
18, Enterprise Center Tower 2, 209# Gong He
Road, Jing'an District, Shanghai, CHINA 200070
Phone : +86-21-6391-3355
Fax : +86-21-6391-3335
<http://www.hirose.com/cn/>

CHINA:

HIROSE ELECTRIC (SHANGHAI) CO.,LTD. BEIJING BRANCH
A1001, Ocean International Center, Building 56# East 4th
Ring Middle Road, ChaoYang District, Beijing, 100025
Phone : +86-10-5165-9332
Fax : +86-10-5908-1381
<http://www.hirose.com/cn/>

CHINA:

HIROSE ELECTRIC TECHNOLOGIES (SHENZHEN) CO., LTD.
Room 09-13, 19/F, Office Tower Shun Hing Square, Di Wang Commercial Centre,
5002 Shen Nan Dong Road, Shenzhen City, Guangdong Province, 518008
Phone : +86-755-8207-0851
Fax : +86-755-8207-0873
<http://www.hirose.com/cn/>

HONG KONG:

HIROSE ELECTRIC HONGKONG TRADING CO., LTD.
Room 1001, West Wing, Tsim Sha Tsui Centre, 66
Mody Road, Tsim Sha Tsui East, Kowloon, Hong Kong
Phone : +852-2803-5338
Fax : +852-2591-6560
<http://www.hirose.com/hk/>

TAIWAN:

HIROSE ELECTRIC TAIWAN CO., LTD.
103 8F, No.87, Zhengzhou Rd., Taipei
Phone : +886-2-2555-7377
Fax : +886-2-2555-7350
<http://www.hirose.com/tw/>

KOREA:

HIROSE KOREA CO.,LTD.
143, Gongdan 1-daero, Siheung-si,
Gyeonggi-do, 15084, Korea
Phone : +82-31-496-7000
Fax : +82-31-496-7100
<http://www.hirose.co.kr/>

SINGAPORE:

HIROSE ELECTRIC SINGAPORE PTE. LTD.
03, Anson Road, #20-01, Springleaf Tower,
Singapore 079909
Phone : +65-6324-6113
Fax : +65-6324-6123
<http://www.hirose.com/sg/>

INDIA:

HIROSE ELECTRIC SINGAPORE PTE. LTD. DELHI LIAISON OFFICE
Office NO.552, Regus-Green Boulevard, Level5, Tower C,
Sec62, Plot B-9A, Block B, Noida, 201301, Uttar Pradesh, India
Phone : +91-12-660-8018
Fax : +91-120-4804949
<http://www.hirose.com/sg/>

INDIA:

HIROSE ELECTRIC SINGAPORE PTE. LTD. BANGALORE LIAISON OFFICE
Unit No-403, 4th Floor, No-84, Barton Centre, Mahatma
Gandhi (MG) Road, Bangalore 560 001, Karnataka, India
Phone : +91-80-4120 1907
Fax : +91-80-4120 9908
<http://www.hirose.com/sg/>

MALAYSIA:

PENANG REPRESENTATIVE OFFICE
73-3-1, Ideal@The One, Jalan Mahsuri, Bayan
Lepas Penang, 11950, Malaysia
Phone : +604-648-5536
<http://www.hirose.com/sg/>

THAILAND:

BANGKOK OFFICE (REPRESENTATIVE OFFICE)
Unit 4703, 47th FL., 1 Empire Tower, South Sathorn
Road, Yannawa, Sathorn, Bangkok 10120 Thailand
Phone : +66-2-686-1255
Fax : +66-2-686-3433
<http://www.hirose.com/sg/>



HIROSE ELECTRIC CO.,LTD.

2-6-3,Nakagawa Chuoh,Tsuzuki-Ku,Yokohama-Shi 224-8540,JAPAN
TEL: +81-45-620-3526 Fax: +81-45-591-3726
<http://www.hirose.com>
<http://www.hirose-connectors.com>