

# MARKETING SALES DRAWING

This drawing is the property of Tusonix, Inc., and may not be used, reproduced, published or disclosed to others without expressed authorization by Tusonix Inc.

**DIMENSIONS IN INCHES - DO NOT SCALE THIS DRAWING**  
**DIMENSIONS IN METRIC - [ ]**

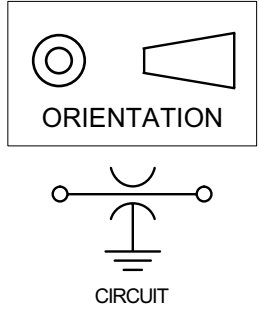

**Electrical Testing**  
per Tusonix standard  
test plans and Mil-Std-202  
Test Methods.

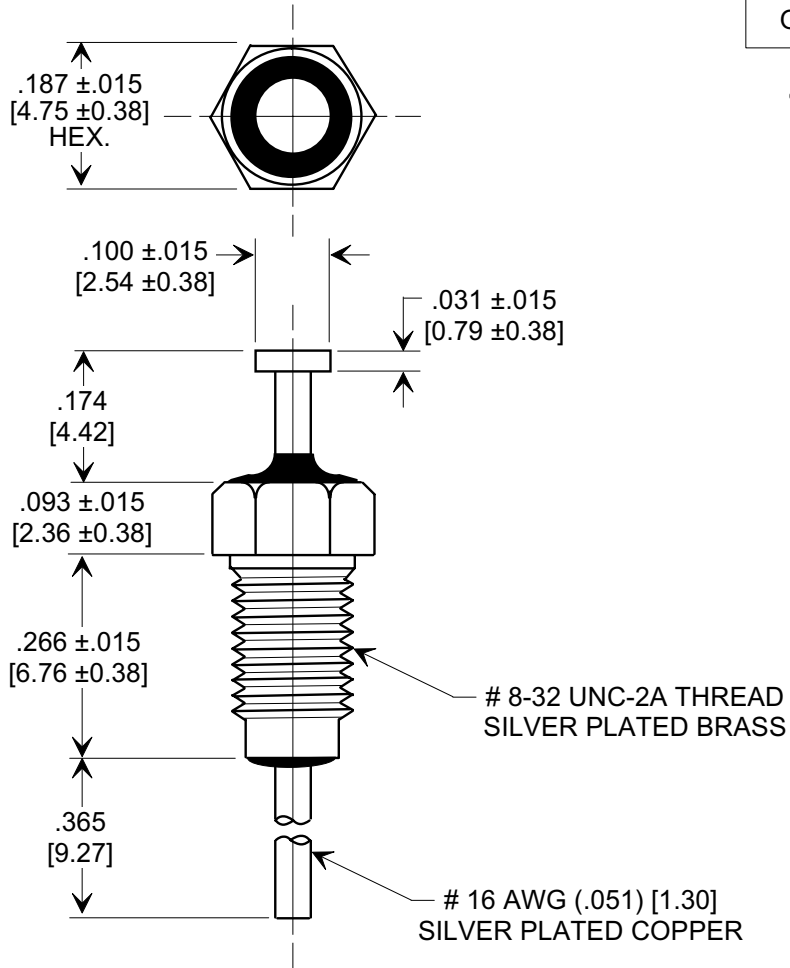

## SPECIFICATIONS

TUSONIX STYLE:	2425-003
CAP. VALUE:	1,000 pF
CAP. TOLERANCE:	GMV
TEMP. CHARACTERISTIC:	X7U
RATING:	200 VDC @ + 85°C/100 VDC @ +125°C
OPERATING RANGE:	-55°C TO + 125°C
CURRENT (A):	20
DWV VDC:	600
Insulation Resistance min @ 100 VDC:	10 GΩ

## NOTES:

- SUPPLIED WITH SILVER PLATED HEX NUT.
- MOUNTING TORQUE NOT TO EXCEED 5 lb-in. [.565 Nm].
- TUSONIX STANDARD PART NUMBER: 2425-003-X7U0-102AA TUSONIX RoHS COMPLIANT PART NUMBER: 2425-003-X7U0-102AA LF. CUSTOMER MUST SPECIFY STANDARD OR RoHS PART NUMBER WHEN ORDERING.
- PART MARKING: STANDARD PART: BLACK INK FOR TRADEMARK AND CAP. CODE. RoHS PART: GREEN INK FOR TRADEMARK AND CAP. CODE.

\* GMV - GUARANTEED MINIMUM VALUE.

<b>REVISION RECORD</b> Original Release C.O. 20030521-1-01 REVISED RATING, ADDED DWV, ADDED & REVISED NOTES, S.M. 03-09-06 20060217-2-15	0	1	--TOLERANCES-- Unless Otherwise Specified	Title <b>MINIATURE BUSHING FEED-THRU</b>	
	DECIMAL ± .031 [079]		Drawn S.M. 05-21-03	Scale 4 X	
	ANGLES ±	Approved T.C. 05-21-03		<b>A</b> 2425-003-X7U0-102AA	
	<b>TUSONIX</b> TUCSON, ARIZONA				