

| REVISIONS |     |                           |         |     |      |
|-----------|-----|---------------------------|---------|-----|------|
| P         | LTR | DESCRIPTION               | DATE    | DMN | APVD |
| P         |     | REVISED PER ECO-15-015252 | 12NOV15 | BJ  | FY   |

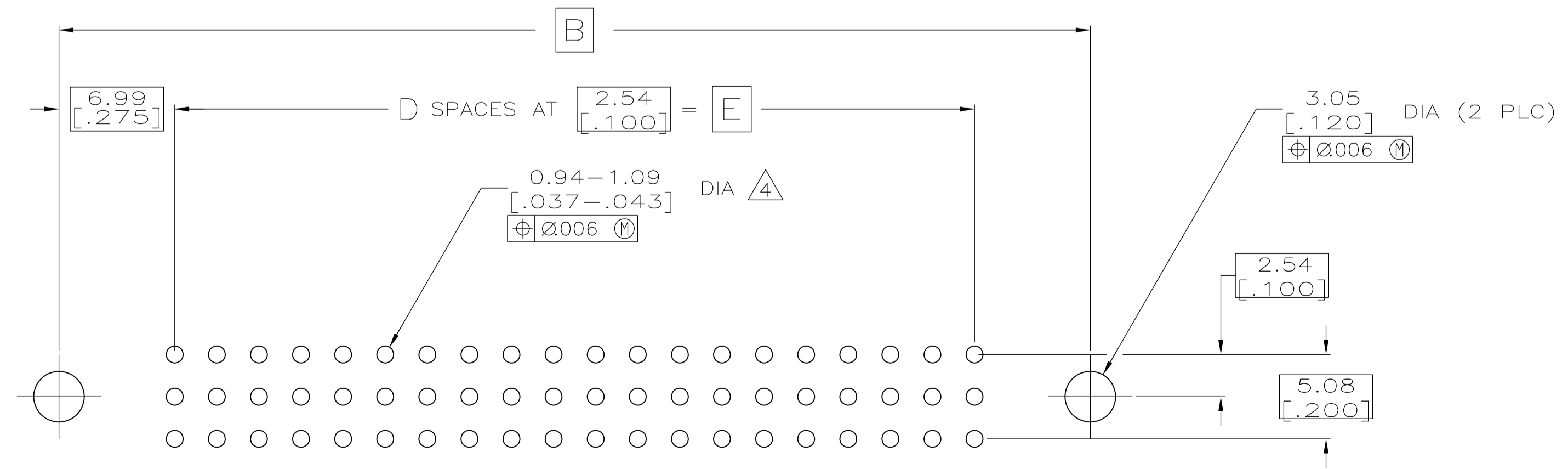

RECOMMENDED P.C. BOARD LAYOUT

|   |  |  |                 |  |
|---|--|--|-----------------|--|
| THIS DRAWING IS A CONTROLLED DOCUMENT.  |  | DIN R.K. SEIFRIED 03/26/90             | TE Connectivity |  |
|   |  | CHK F. KIBLER 8-18-92                  |                 |  |
| DIMENSIONS: mm [INCHES]   |  | TOLERANCES UNLESS OTHERWISE SPECIFIED: |                 | NAME HDI, 3 ROW, PIN ASSEMBLY, 18.62 [.733] LONG ACTION PINS |
| 0 PLC ± -<br>1 PLC ± -<br>2 PLC ± -<br>3 PLC ± 0.13 [.005]<br>4 PLC ± -<br>ANGLES ± - |  | APVD -                                 |                 | PRODUCT SPEC -   |
| MATERIAL  |  | FINISH                                 |                 | APPLICATION SPEC -   |
| 1<br>2  |  | 3                                      |                 | SIZE A1  |
| CUSTOMER DRAWING  |  | SCALE 4:1                              |                 | WEIGHT   |
|   |  | SHEET 1 OF 2                           |                 | DRAWING NO. 00779  |
|   |  | REV P                                  |                 | DATE 5/32/432  |

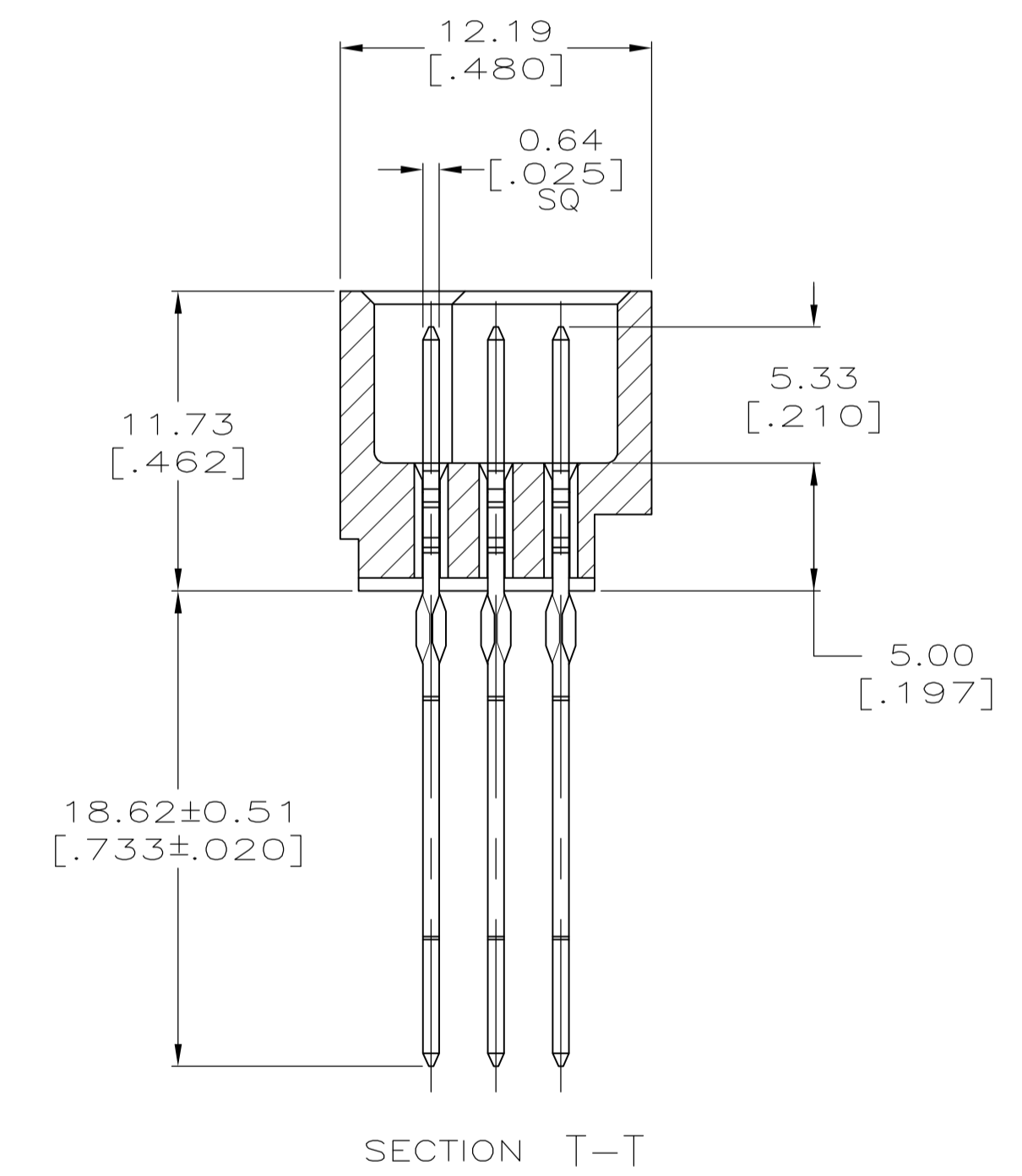
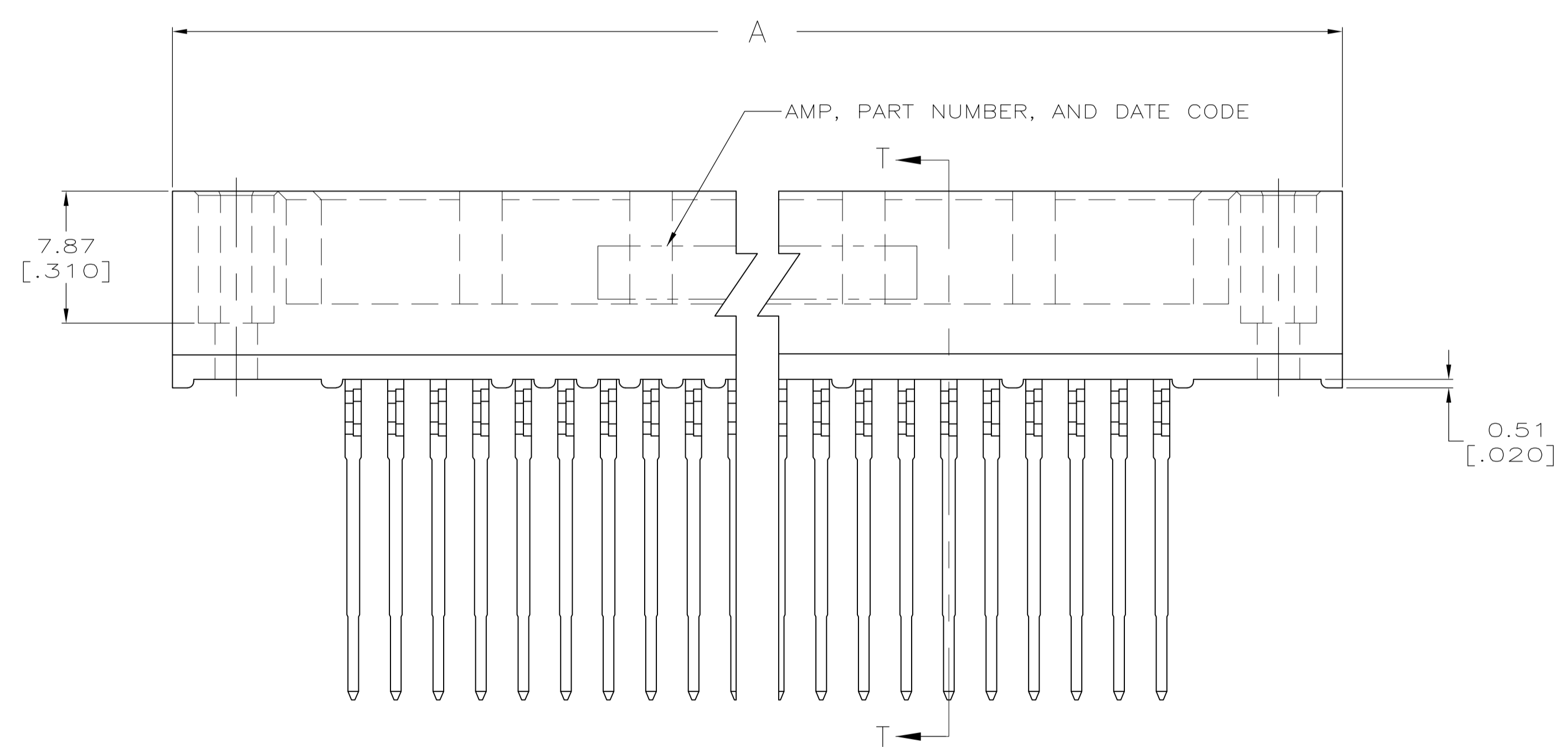
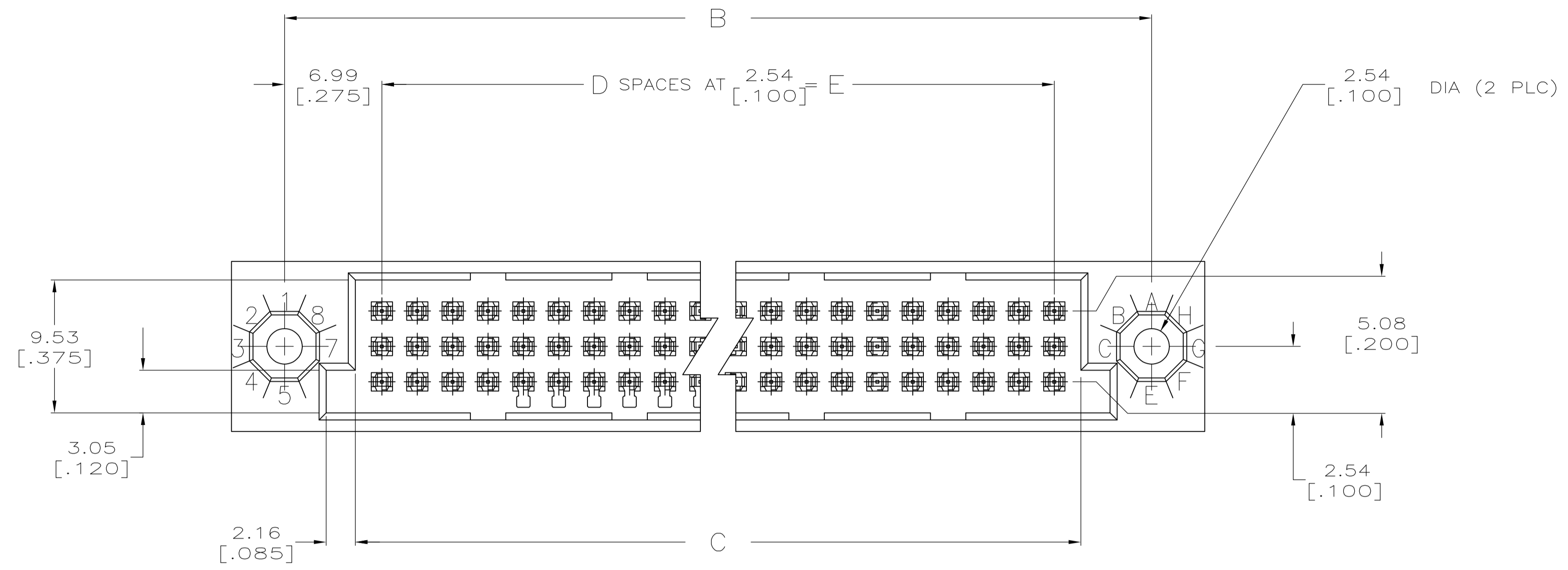