

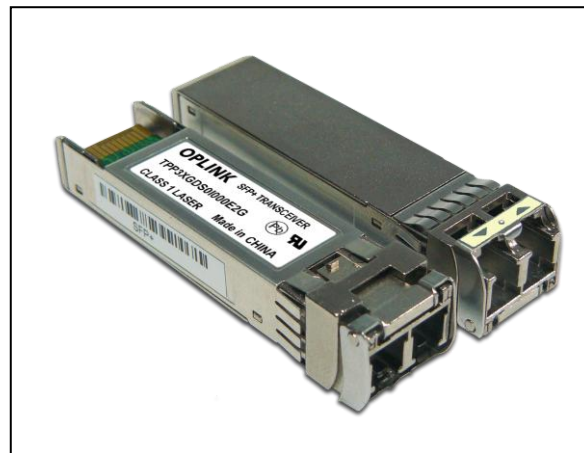

Features

- ☑ 850nm VCSEL laser
- ☑ Transmission distance up to 300m on OM3 MM fiber
- ☑ Low power consumption
- ☑ Wide Case Operating Temperature Range
- ☑ Compliant with SFP+ Electrical MSA SFF-8431
- ☑ Compliant with SFP+ Mechanical MSA SFF-8432
- ☑ Digital Diagnostics Monitoring (DDM) through Serial Interface comply with SFF-8472, Rev. 10.4
- ☑ RoHS 6/6 compliant
- ☑ Compliant with product safety standards



Description

The TPP3XGDS0x000E2G is an enhanced small form factor pluggable (SFP+) fiber optic transceiver with digital diagnostics monitoring functionality (DDM). Supporting Ethernet and Fiber Channel standards makes it ideally suited for 10Gbps data-com and storage area network applications. DDM functionality (alarm and warning features) is integrated into the design via an I²C serial interface per the Multi-Source Agreement (MSA) SFF-8472, Rev. 10.4.

The transceiver supports data rates ranging from 11.3Gbps down to 8Gbps. It provides an excellent solution for transmission at 850nm over up to 300m 2000MHz-km multimode fiber. The sub-watt power consumption and excellent EMI performance allow system design with high port density. The product is RoHS compliant and is designed and tested in accordance with industry safety standards. The transceiver is Class I Laser product per U.S. FDA/CDRH and international IEC-60825 standards.

The TPP3XGDS0x000E2G transceiver connects to standard 20-pad SFP+ connectors for hot plug capability. This allows the system designer to make configuration changes or maintenance by simply plugging in different transceivers without removing the power supply from the host system. The transmitter and receiver DATA interfaces are internally AC-coupled. LV-TTL Transmitter Disable control input and Loss of Signal (LOS) output interfaces are also provided.

The transceiver has bail-type latch, which offers an easy and convenient way to release the modules. The latch is compliant with the SFP MSA.

The transceiver operates from a single +3.3V power supply over an operating case temperature range of -5°C to +70°C (Commercial), or -5°C to +85°C (Extended). The housing is made of metal for EMI immunity.

Absolute Maximum Ratings

Parameters	Symbol	Min	Max	Units
Storage Temperature Range	T_{ST}	- 40	+ 85	°C
Operating Temperature Range ¹	Commercial	- 5	+ 70	°C
	Extended	- 5	+ 85	
Operating Relative Humidity ²	RH	0	85	%
Supply Voltage Range	V_{CC}	- 0.5	+ 3.6	V

¹ Measured on top side of SFP+ module at the front center vent hole of the cage
² Non condensing

Transmitter Performance Characteristics (Over Operating Case Temperature, $V_{CC}=3.13$ to $3.47V$)

Parameter	Symbol	Min	Typ	Max	Units
Data Rate	B	8.0	-	11.3	Gb/s
Center Wavelength	λ_C	840	850	860	nm
Spectral Width	$\Delta\lambda_{rms}$	-	-	0.45	nm
Average Launch Power ¹	P_{avg}	- 5	-	- 1	dBm
Launch Power in OMA ¹	P_{OMA}	-	- 1.5	-	dBm
Extinction Ratio	ER	3	-	-	dB
Relative Intensity Noise	RIN_{12OMA}	-	-	- 128	dB/Hz
Average Launch Power of OFF Transmitter	P_{off}	-	-	- 30	dBm
Transmitter and Dispersion Penalty @ 10.3125Gb/s	TDP	-	-	3.9	dB

¹ Launch power figures are informative only, per IEEE 802.3ae.

Receiver Performance Characteristics (Over Operating Case Temperature, $V_{CC}=3.13$ to $3.47V$)

Parameter	Symbol	Min	Typ	Max	Units
Data Rate	B	8.0	-	11.3	Gb/s
Wavelength of Operation	λ	840	-	860	nm
Receiver Sensitivity	P_{avg} @ 10.3125Gb/s ¹	-	-	- 9.9	dBm
	OMA @ 10.3125Gb/s ¹	-	-	- 11.1	
Stressed Receiver Sensitivity in OMA (@10.3125Gb/s) ²	-	-	-	- 7.5	dBm
Maximum Input Power (10^{-12} BER)	P_{MAX}	+ 0.5	-	-	dBm
LOS Hysteresis	-	0.5	-	-	dB
LOS Thresholds	Increasing Light Input	-	-	- 11	dBm
	Decreasing Light Input	- 30	-	-	

¹ Specified with BER $<1 \times 10^{-12}$ and PRBS $2^{31}-1$.
² Compliant with IEEE 802.3ae

Note: The specified characteristics are met within the recommended range of operation. Unless otherwise noted typical data are quoted at nominal voltage and +25°C ambient temperature.

Laser Safety:

All transceivers are Class I Laser products per FDA/CDRH and IEC-60825 standards. They must be operated under specified operating conditions.



Oplink Communications, Inc.

DATE OF MANUFACTURE:

This product complies with
21 CFR 1040.10 and 1040.11
Meets Class I Laser Safety Requirements

Transmitter Electrical Characteristics (Over Operating Case Temperature, $V_{CC}=3.13$ to $3.47V$)

Parameter	Symbol	Min	Typ	Max	Units
Differential Input Impedance	Z_d	-	100	-	Ω
Differential Input Voltage Swing	$V_{PP-DIFF}$	180	-	700	mV
Input High Voltage (TX Disable) ¹	V_{IH}	2.0	-	V_{CC}	V
Input LOW Voltage (TX Disable) ¹	V_{IL}	0	-	0.8	V
Output High Voltage (TX Fault) ²	VOH	2.0	-	$V_{CC}+0.3$	V
Output LOW Voltage (TX Fault) ²	VOL	0	-	0.8	V

¹There is an internal 4.7 k Ω to 10 k Ω pull-up resistor to V_{CC}
²Open collector compatible, 4.7 k Ω to 10 k Ω pull-up resistor to V_{CC} (Host Supply Voltage)

Receiver Electrical Characteristics (Over Operating Case Temperature, $V_{CC}=3.13$ to $3.47V$)

Parameter	Symbol	Min	Typ	Max	Units
Differential Output Impedance	Z_d	-	100	-	Ω
Differential Output Swing	$V_{PP-DIFF}$	300	450	850	mV
Output Rise and Fall time 20% to 80%	t_{RH}, t_{FH}	24	-	-	ps
Output HIGH Voltage (LOS) ¹	VOH	$V_{CC}-1.3$	-	$V_{CC}+0.3$	V
Output Low Voltage (LOS) ¹	VOL	0	-	0.8	V

¹Open collector compatible, 4.7 k Ω to 10k Ω pull-up resistor to V_{CC} (Host Supply Voltage)

Electrical Power Supply Characteristics (Over Operating Case Temperature, $V_{CC}=3.13$ to $3.47V$)

Parameter	Symbol	Min	Typ	Max	Units
Power Supply Voltage	V_{CC}	3.13	3.30	3.47	V
DC Common Mode Voltage	V_{CM}	0	-	3.6	V
Supply Current ¹	I_{VCC}	-	-	280	mA
Power Consumption	P_W	-	0.6	1.0	W

Note: The specified characteristics are met within the recommended range of operation. Unless otherwise noted typical data are quoted at nominal voltage and +25°C ambient temperature.

Connector Pin-out

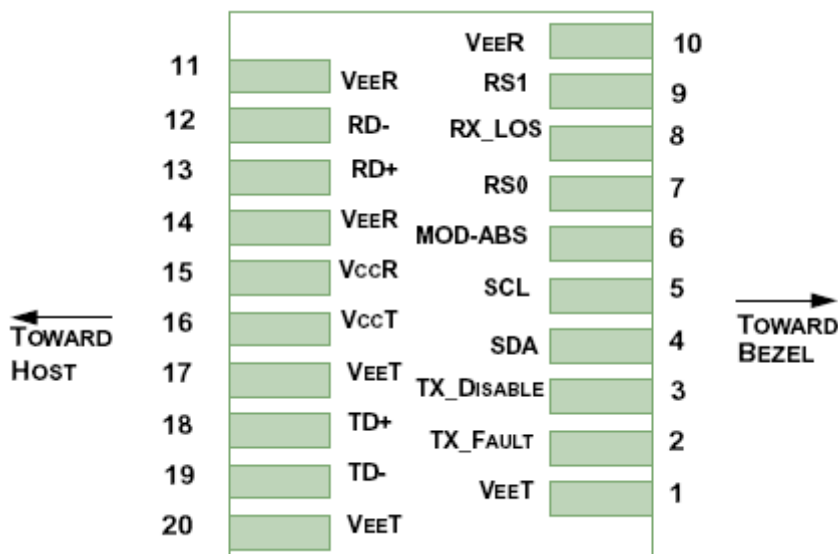

Electrical Pin Definition

PIN	Logic	Symbol	Name / Description
1	-	<i>VeeT</i>	Module Transmitter Ground
2	LVTTL-O	<i>TX_Fault</i>	Module Transmitter Fault
3	LVTTL-I	<i>TX_Disable</i>	Transmitter Disable; Turns off transmitter laser output
4	LVTTL-I/O	<i>SDA</i>	2-Wire Serial Interface Data Line
5	LVTTL-I/O	<i>SCL</i>	2-Wire Serial Interface Clock
6	-	<i>MOD-ABS</i>	Module Definition, Grounded in the module
7	LVTTL-I	<i>RS0</i>	No function implemented
8	LVTTL-O	<i>RX_LOS</i>	Receiver Loss of Signal Indication
9	LVTTL-I	<i>RS1</i>	No function implemented
10	-	<i>VeeR</i>	Module Receiver Ground
11	-	<i>VeeR</i>	Module Receiver Ground
12	CML-O	<i>RD-</i>	Receiver Inverted Data Output
13	CML-O	<i>RD+</i>	Receiver Non-Inverted Data Output
14	-	<i>VeeR</i>	Module Receiver Ground
15	-	<i>VccR</i>	Module Receiver 3.3V Supply
16	-	<i>VccT</i>	Module Transmitter 3.3V Supply
17	-	<i>VeeT</i>	Module Transmitter Ground
18	CML-I	<i>TD+</i>	Transmitter Non-Inverted Data Input
19	CML-I	<i>TD-</i>	Transmitter Inverted Data Input
20	-	<i>VeeT</i>	Module Transmitter Ground

Application Notes

Electrical interface: All signal interfaces are compliant with the SFP+ MSA specification. The high speed DATA interface is differential AC-coupled internally and can be directly connected to a 3.3V SERDES IC. All low speed control and sense output signals are open collector TTL compatible and should be pulled up with a 4.7 k Ω - 10k Ω resistor on the host board.

Loss of Signal (LOS): The Loss of Signal circuit monitors the level of the incoming optical signal and generates logic HIGH when an insufficient photocurrent is produced.

TX Fault: The output indicates LOW when the transmitter is operating normally and HIGH with a laser fault including laser end-of-life. TX Fault is an open collector/drain output and should be pulled up with a 4.7 k Ω - 10k Ω resistor on the host board.

TX Disable: When the TX Disable pin is at logic HIGH, the transmitter optical output is disabled. The laser is also disabled if this line is left floating, as it is pulled high inside the transceiver.

Serial Identification and Monitoring: The module definition of SFP is indicated by the MOD_ABS pin and the

2-wire serial interface. Upon power up, the 2-wire interface appears as NC (no connection), and MOD_ABS is TTL LOW. When the host system detects this condition, it activates the serial protocol (standard two-wire I²C serial interface) and generates the serial clock signal (SCL). The positive edge clocks data into the EEPROM segments of the device that are not write protected, and the negative edge clocks data from the device. The serial data signal (SDA) is for serial data transfer. The host uses SDA in conjunction with SCL to mark the start and end of serial protocol activation. The supported monitoring functions are temperature, voltage, bias current, transmitter power, average receiver signal, all alarms and warnings, and software monitoring of TX Fault/LOS. The device is internally calibrated.

The data transfer protocol and the details of the mandatory and vendor specific data structures are defined in the SFP MSA, and SFF-8472, Rev. 10.4.

Power supply and grounding: The power supply line should be well-filtered. All power supply bypass capacitors should be as close to the transceiver module as possible.

Interfacing the Transceivers

Communication is via a serial 2-wire serial interface. As described in the document SFF-8472 (REV. 10.4) there are two distinct address spaces:

Base Address A0(hex)	
Byte Address	Content
0 – 95	Serial Transceiver ID as defined in SFP MSA
96 – 127	OPLINK Specific
128 – 255	Reserved

Base Address A2(hex)	
Byte Address	Content
0 - 55	Alarm & Warnings thresholds & limits
56 - 95	External calibration constants (not used)
96 – 119	Values from real time diagnostic monitoring
120 – 127	Not used
128 – 247	Customer specific, writable area
248 - 255	Not used

Application Schematics

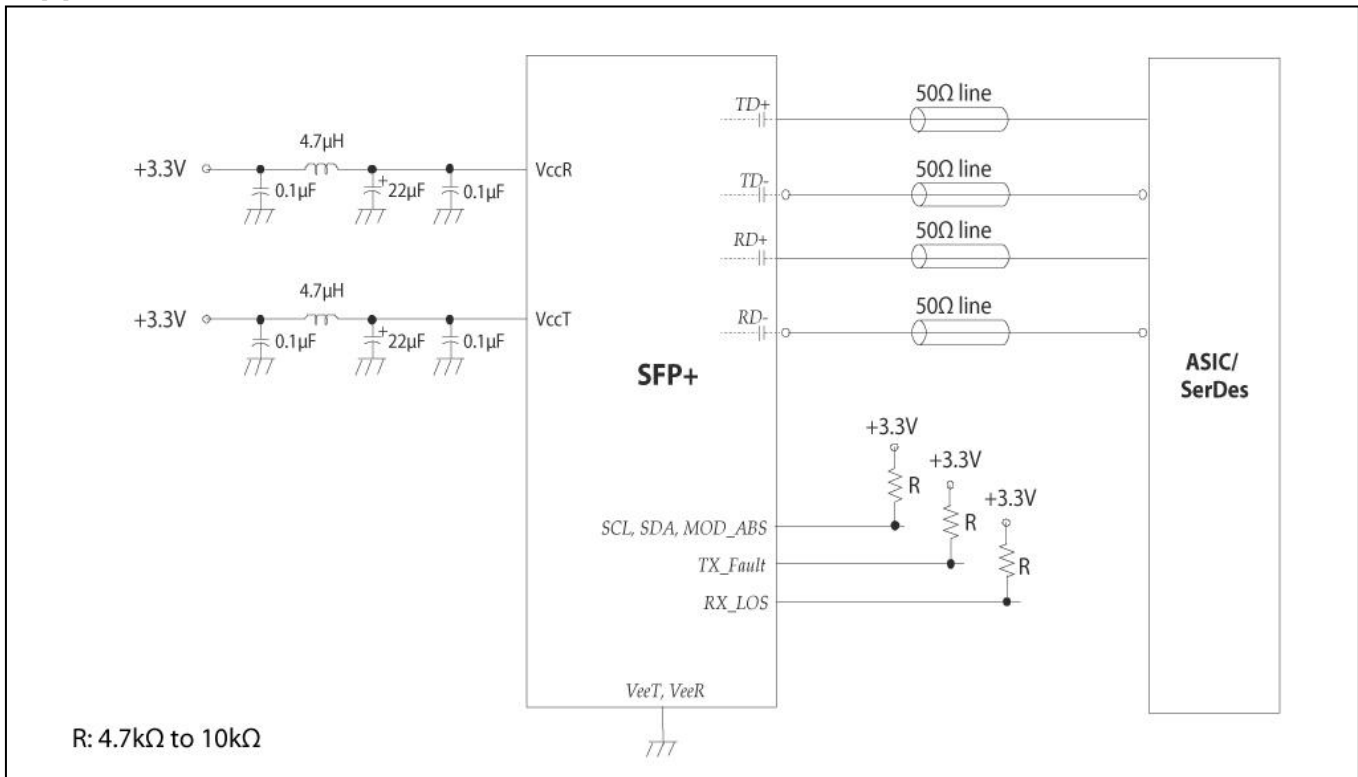

ESD & Electromagnetic Compatibility

Requirements	Standard	Status
Electro Static Discharge to the Electrical Pins (ESD)	EIA/JESD22-A114-B MIL-STD 883C Method 3015.7	Exceeds requirements Class 1B (>1000V)
Immunity to ESD (housing, receptacle)	IEN 61000-4-2	Exceeds requirements Discharges ranging from 2kV to 15kV without damages to the transceiver
Electromagnetic Emission (EMI)	FCC Part 15, Class B EN 55022 Class B CISPR 22	Exceeds requirements Class B

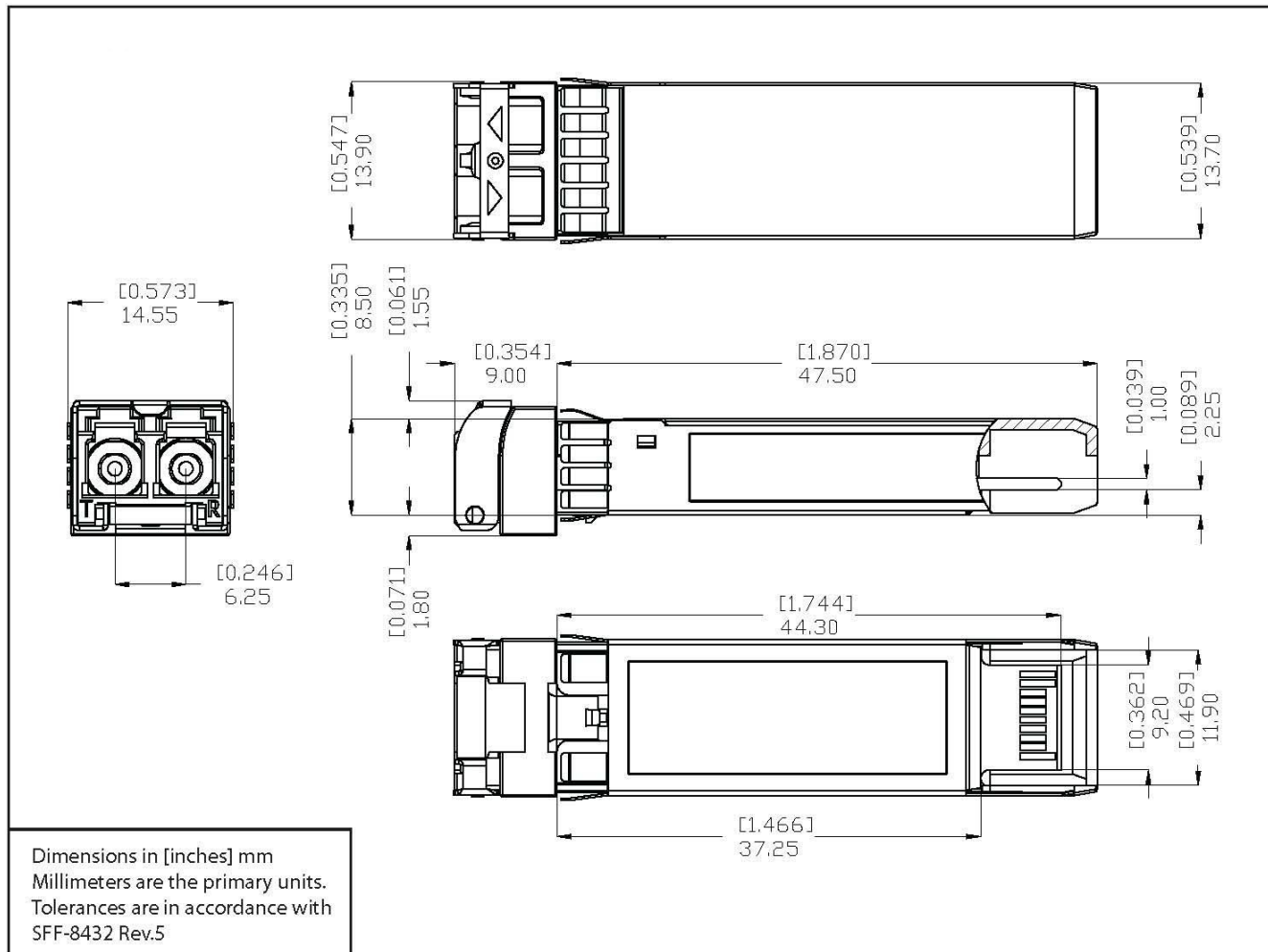

Ordering Information

Model Name	Operating Temperature	Nominal Wavelength (nm)	Distance (m)
TPP3XGDS0C000E2G	- 5°C to + 70°C	850	300
TPP3XGDS0E000E2G	- 5°C to + 85°C	850	300

Oplink Communications, Inc. reserves the right to make changes in equipment design or specifications without notice. Information supplied by Oplink Communications, Inc. is believed to be accurate and reliable. However, no responsibility is assumed by Oplink Communications, Inc. for its use nor for any infringements of third parties, which may result from its use. No license is granted by implication or otherwise under any patent right of Oplink Communications, Inc.

©2012 Oplink Communications, Inc.

Mouser Electronics

Authorized Distributor

Click to View Pricing, Inventory, Delivery & Lifecycle Information:

Molex:

[TPP3XGDS0C000E2G](#)