

REVISIONS			
REV	DESCRIPTION	DATE	APPROVED
01 <sub>0</sub>	RELEASED	KYLE 7-8-97	<i>[Signature]</i> 7/14/97

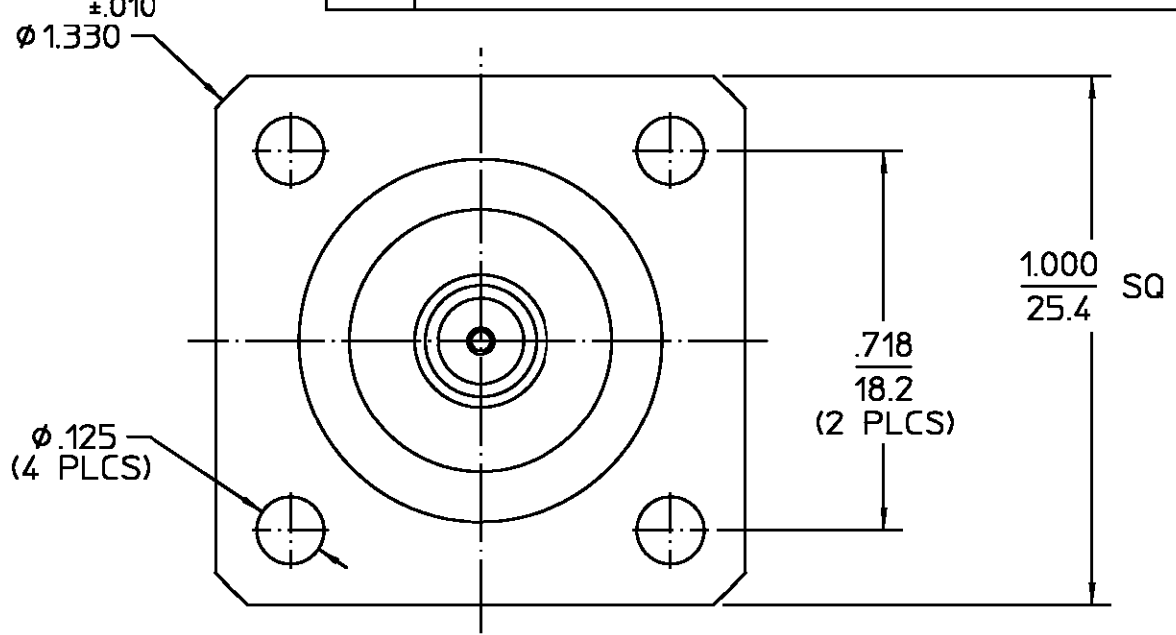

HOUSING COUPLING NUT	STAINLESS STEEL PER ASTM-A484 AND ASTM-A582, TYPE 303	PASSIVATE PER QQ-P-35
DIELECTRIC	PTFE FLUOROCARBON PER ASTM-D-1457	N/A
CENTER CONTACT	BERYLLIUM COPPER PER ASTM-B-196 OR ASTM-B-197, ALLOY C17300, CONDITION H	GOLD PLATE PER MIL-G-45204
RETAINING RING	BERYLLIUM COPPER PER ASTM-B-194, ALLOY C17200, CONDITION H	N/A
GASKET	SILICONE RUBBER PER ZZ-R-765	N/A

COMPONENT	MATERIAL	FINISH
-----------	----------	--------

UNLESS OTHERWISE SPECIFIED DIMENSIONS ARE IN INCHES FRAC. ± 1/64 DEC. ±.005 ANGLES ± 1°	DRAWN BY KYLE LE 7-8-97	AMP Incorporated 140 Fourth Avenue Waltham, MA 02451-7599
	CHECKED BY	
	APPD BY <i>[Signature]</i> 7/14/97	

THESE DRAWINGS AND SPECIFICATIONS ARE THE PROPERTY OF M/A COM INTERCONNECT DIV. AND SHALL NOT BE REPRODUCED OR COPIED OR USED IN WHOLE OR IN PART AS THE BASIS FOR THE MANUFACTURE OR SALE OF ITEM(S) WITHOUT WRITTEN PERMISSION.	USE ASSY PROCEDURE	TITLE HIGH FREQ "OSN" PLUG TO "OSM" JACK FLANGE MOUNT-ADAPTER	
	NO. A.P. N/A	SIZE B	CODE IDENT NO. 3682-2242-00
		SCALE 3:1	REV 01 <sub>0</sub>

NOTES:  
HIGH FREQ. TO 18.0 GHz  
MAX. VSWR .83 + .023 f(GHz)

.XXX = in  
XX.X = mm (REF)