

REVISIONS			
REV	DESCRIPTION	DATE	APPROVED
01 ₄	REVISED	KYLE 7-25-97	 8/5/97

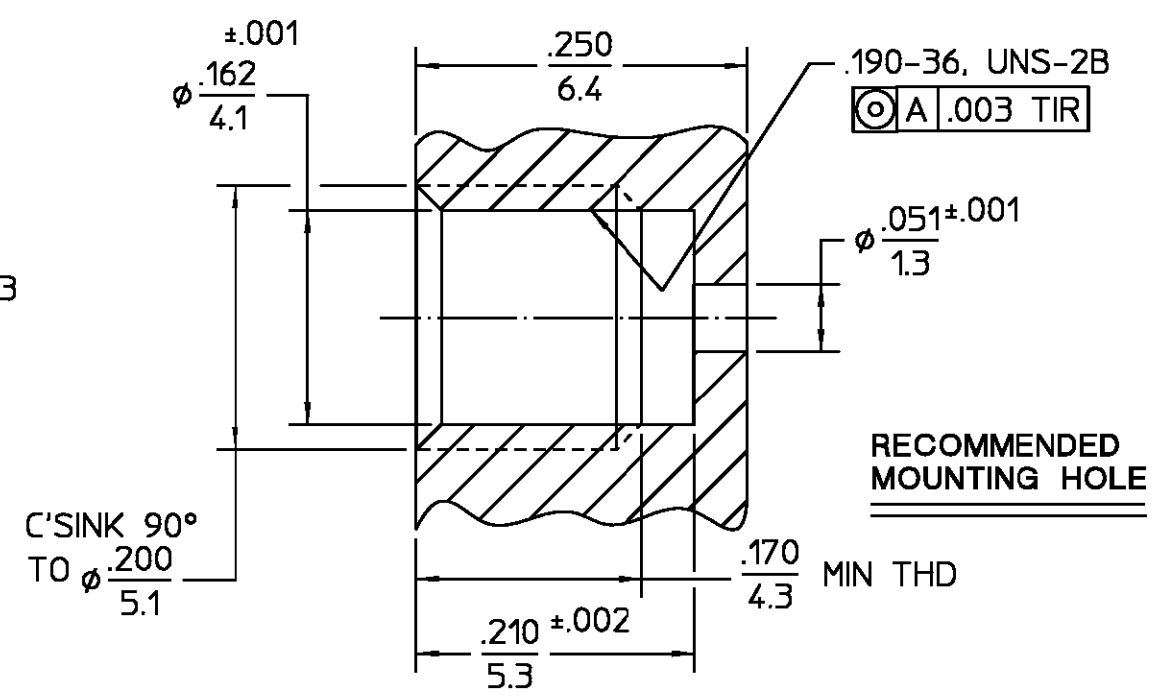
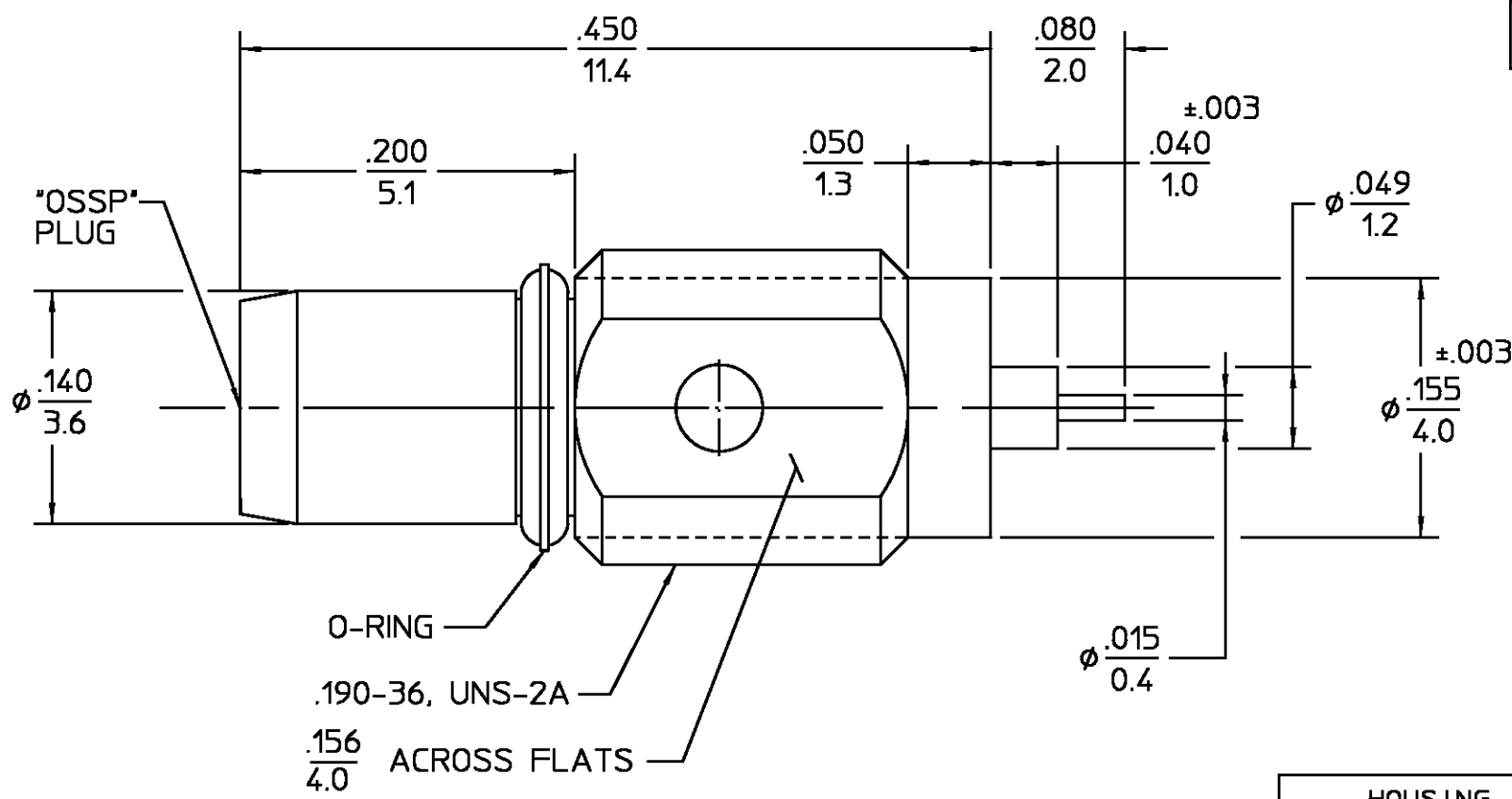

ELECTRICAL
Nominal Impedance (Ohms) <u>50</u>
Frequency Range (GHz) DC to <u>28.0</u>
Volt Rating (VRMS MAX) @ Sea Level <u>250</u>
VSWR <u>1.33:1</u> @ 28.0 GHz <u>1.05 + .001f(GHz)</u>
Insertion Loss (dB MAX) <u>.04 √f(GHz)</u>
RF Leakage (dB MIN) <u>-[60-f(GHz)]</u>
Corona, 70,000 Ft (VRMS MIN) <u>250</u>
Dielectric Withstanding Voltage (VRMS MIN) @ Sea Level <u>675</u>
Contact Resistance (Milliohms MAX) Center Contact <u>6.0</u> Outer Contact <u>3.0</u>
RF High Potential @ Sea Level (VRMS MIN @ 5 MHz) <u>675</u>
LR.(Megohms MIN) <u>5,000</u>

MECHANICAL
Interface Dimensions PER <u>M/A-COM CATALOG</u>
Mating Characteristics: Insertion (MAX Lbs) <u>2.0</u> Withdrawal (MIN Oz) <u>0.5</u>
Force to Engage and Disengage (In-Lbs MAX) <u>0.4</u>
Center Contact Captivation Axial (Lbs) <u>4.0</u>

ENVIRONMENTAL
Temperature Rating <u>-65° TO +125°C</u>
Vibration MIL-STD-202, Method 204, Condition D
Shock MIL-STD-202, Method 213, Condition I
Thermal Shock MIL-STD-202, Method 107, Condition B
Moisture Resistance MIL-STD-202, Method 106
Corrosion - MIL-STD-202, Method 101, Condition B, 5% salt spray
 <u>.XXX = in</u> <u>XX.X = mm (REF)</u>

COMPONENT	MATERIAL	FINISH
HOUSING	STAINLESS STEEL PER ASTM-A484 AND ASTM- A582, TYPE 303	PASSIVATE PER QQ-P-35
DIELECTRIC	PTFE FLUOROCARBON PER ASTM-D-1457	N/A
CENTER CONTACT	BERYLLIUM COPPER PER ASTM-B-196 OR ASTM-B-197, ALLOY C17300, CONDITION H	GOLD PLATE PER MIL-G-45204
O-RING	FLUOROSILICONE 60 (DUROMETER) PER MIL-P-25988, CLASS 1, TYPE 1	N/A

UNLESS OTHERWISE SPECIFIED DIMENSIONS ARE IN INCHES		DRAWN BY PCV		DATE 9-15-86		 AMP Incorporated 140 Fourth Avenue Waltham, MA 02451-7599	
FRAC. DEC. ANGLES ± 1/64 ±.005 ± 1°		CHECKED BY MH/M		DATE 10-1-86			
		APPD BY PCV		DATE 10-20-86			
These drawings and specifications are the property of M/A COM Interconnect Div. and shall not be reproduced or copied or used in whole or in part as the basis for the manufacture or sale of a item(s) without written permission.		USE ASSY PROCEDURE		TITLE 'OSSP' PANEL FEEDTHRU PLUG RECEPTACLE- STRAIGHT TERMINAL			
NO. A.P. <u>47-014</u>		SIZE B	CODE IDENT NO. 26805	4757-5006-02		REV 01 ₄	
		SCALE 10:1				SHEET 1 OF 1	

CUSTOMER DRAWING

AMP PART # 1059903-1
SHEET 1 OF 1 REV B
PER EC # 0U20-0261-01