

THIS DRAWING IS UNPUBLISHED. RELEASED FOR PUBLICATION  
 © COPYRIGHT BY TYCO ELECTRONICS CORPORATION. ALL RIGHTS RESERVED.

LOC	DIST	REVISIONS					
FT	0	P	LTR	DESCRIPTION	DATE	DWN	APVD
		B1		REVISED PER ECO-05-16002	12/14/05	SS	GS

- ① .000100 MIN TIN-LEAD PLATE OVER .000050 MIN NICKEL UNDERPLATE.
- ② .000100 MIN TIN PLATE OVER .000050 MIN NICKEL UNDERPLATE.

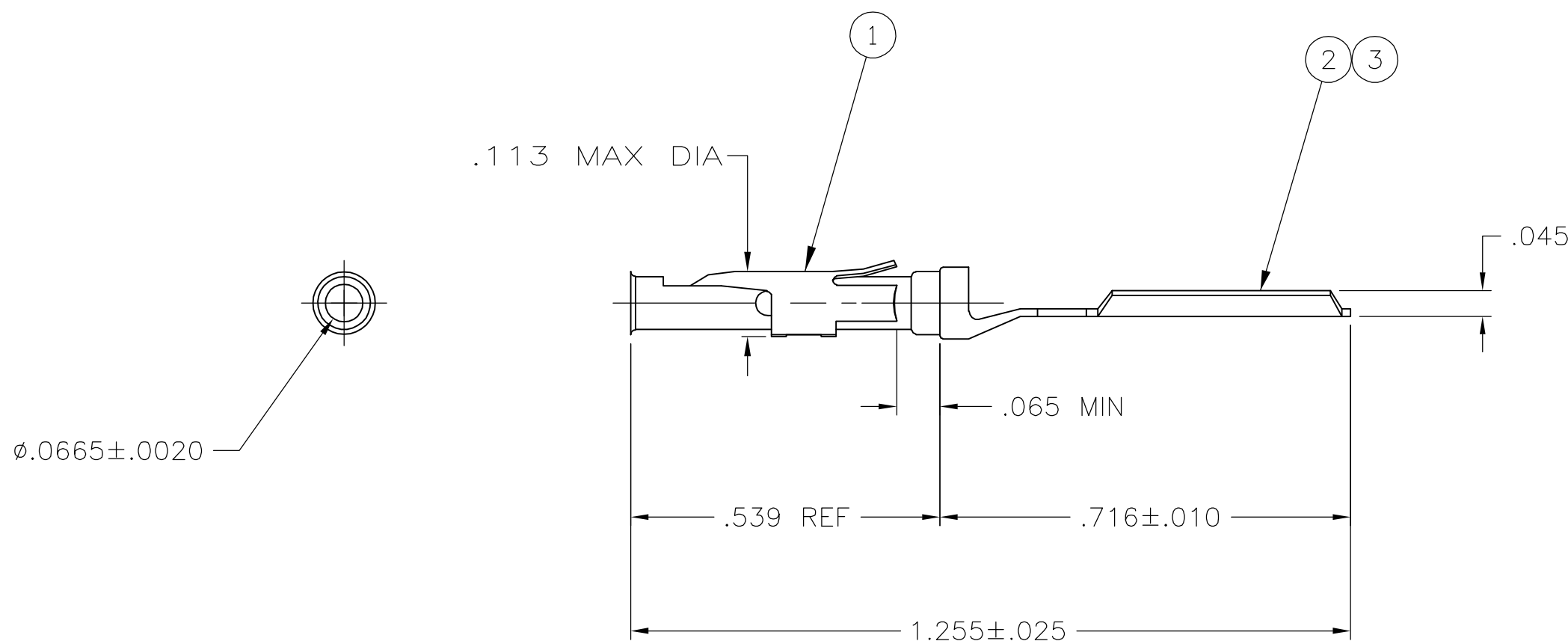
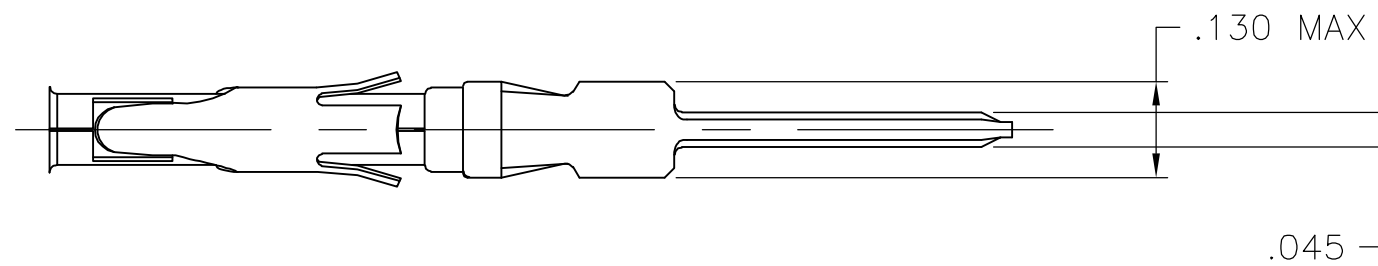

②	FULL HARD, BRASS	SOCKET	③	1776003-3
-	STAINLESS STEEL	SPRING	①	
①	FULL HARD, BRASS	SOCKET	②	1776003-2
-	STAINLESS STEEL	SPRING	①	
FINISH	MATERIAL	COMPONENT, ITEM NO	PART NUMBER	
THIS DRAWING IS A CONTROLLED DOCUMENT.		DWN M.S. FEHER 19MAR2004	Tyco Electronics Corporation Harrisburg, PA 17105-3608	
		CHK G STEINHAUER 23MAR2004		
DIMENSIONS: INCHES		APVD G STEINHAUER 23MAR2004	NAME	
TOLERANCES UNLESS OTHERWISE SPECIFIED:		PRODUCT SPEC	SOCKET CONTACT ASSEMBLY, .062 DIA RECEPTACLE, .045 POST	
 0 PLC ± - 1 PLC ± - 2 PLC ± - 3 PLC ± .005 4 PLC ± - ANGLES ± - FINISH		APPLICATION SPEC	SIZE A2	CAGE CODE 00779
MATERIAL SEE TABLE		WEIGHT -	DRAWING NO C=1776003	RESTRICTED TO -
		CUSTOMER DRAWING	SCALE 4:1	SHEET 1 of 1 REV B1